

National Semiconductor is now part of
Texas Instruments.

Search <http://www.ti.com/> for the latest technical
information and details on our current products and services.

LMV7231

Hex Window Comparator with 1.5% Precision and 400mV Reference

General Description

The LMV7231 is a 1.5% accurate Hex Window Comparator which can be used to monitor power supply voltages. The device uses an internal 400mV reference for the comparator trip value. The comparator set points can be set via external resistor dividers. The LMV7231 has 6 outputs (CO1-CO6) that signal an under-voltage or over-voltage event for each power supply input. An output (AO) is also provided to signal when any of the power supply inputs have an over-voltage or under-voltage event. This ability to signal an under-voltage or over-voltage event for the individual power supply inputs, in addition to an output to signal such an event on any of the power supply inputs adds unparalleled system protection capability.

The LMV7231's +2.2V to +5.5V power supply voltage range, low supply current, and input/output voltage range above V+ make it ideal for a wide range of power supply monitoring applications. Operation is guaranteed over the -40°C to +125°C temperature range. The device is available in a 24-pin LLP package.

Features

(For $V_S = 3.3V \pm 10\%$, Typical unless otherwise noted)

- High accuracy voltage reference: 400 mV
- Threshold Accuracy: $\pm 1.5\%$ (max)
- Wide supply voltage range +2.2V to +5.5V
- Input/Output voltage range above V+
- Internal hysteresis: 6mV
- Propagation delay: 2.6 μs to 5.6 μs
- Supply Current 7.7 μA per channel
- 24 lead LLP package
- Temperature range: -40°C to 125°C

Applications

- Power Supply Voltage Detection
- Battery Monitoring
- Handheld Instruments
- Relay Driving
- Industrial Control Systems

Typical Application Circuit

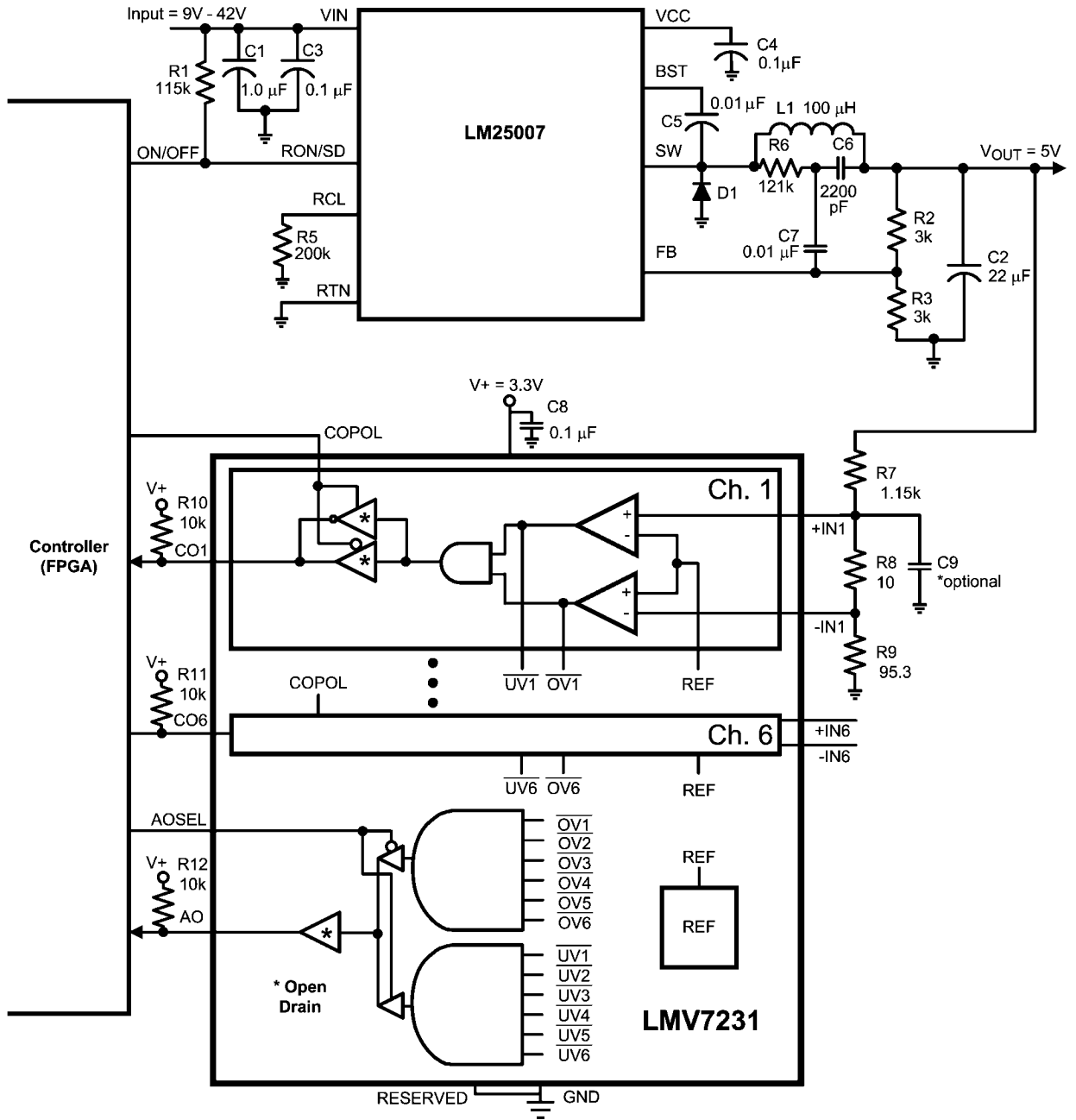

30114944

Absolute Maximum Ratings (Note 1)

If Military/Aerospace specified devices are required, please contact the National Semiconductor Sales Office/Distributors for availability and specifications.

Junction Temperature (Note 3) 150°C

For soldering specifications:

see product folder at www.national.com and
www.national.com/ms/MS/MS-SOLDERING.pdf

Operating Ratings (Note 1)

Supply Voltage 2.2V to 5.5V

Junction Temperature Range (Note 3) -40°C to +125°C

Package Thermal Resistance, θ_{JA}
24 Lead LLP 38°C/W

ESD Tolerance (Note 2)

Human Body Model	2000V
Machine Model	200V
Supply Voltage	6V
Voltage at Input/Output Pin	6V to (GND - 0.3V)
Output Current	10mA
Total Package Current	50mA
Storage Temp Range	-65°C to +150°C

+3.3V Electrical Characteristics Unless otherwise specified, all limits guaranteed for $T_A = 25^\circ\text{C}$, $V_+ = 3.3\text{V}$, $\pm 10\%$, $\text{GND} = 0\text{V}$, and $R_L > 1\text{M}\Omega$. **Boldface limits apply for $T_A = -10^\circ\text{C}$ to $+70^\circ\text{C}$.**

Symbol	Parameter	Condition	Min (Note 5)	Typ (Note 4)	Max (Note 5)ns	Units
V_{THR}	Threshold: Input Rising	$R_L = 10\text{k}\Omega$	394 391.4	400	406 408.6	mV
V_{THF}	Threshold: Input Falling	$R_L = 10\text{k}\Omega$	386 383.8	394	401 403.2	mV
V_{HYST}	Hysteresis ($V_{THR} - V_{THF}$)	$R_L = 10\text{k}\Omega$	3.9	6.0	8.8	mV
I_{BIAS}	Input Bias Current	$V_{IN} = V_+$, GND, and 5.5V	-5 -15	0.05	5 15	nA
V_{OL}	Output Low Voltage	$I_L = 5\text{mA}$		160	200 250	mV
I_{OFF}	Output Leakage Current	$V_{OUT} = V_+$, 5.5V and 40mV of overdrive			0.4 1	μA
t_{PDHL1}	High-to-Low Propagation Delay (+IN falling)	10mV of overdrive		2.6	6	μs
t_{PDHL2}	High-to-Low Propagation Delay (-IN rising)	10mV of overdrive		5.4	10	μs
t_{PDLH1}	Low-to-High Propagation Delay (+IN rising)	10mV of overdrive		5.6	10	μs
t_{PDLH2}	Low-to-High Propagation Delay (-IN falling)	10mV of overdrive		2.8	6	μs
t_r	Output Rise Time	$C_L = 10\text{pF}$, $R_L = 10\text{k}\Omega$		0.5		μs
t_f	Output Fall Time	$C_L = 100\text{pF}$, $R_L = 10\text{k}\Omega$			0.25 0.3	μs
$I_{IN(1)}$	Digital Input Logic "1" Leakage Current				0.2 1	μA
$I_{IN(0)}$	Digital Input Logic "0" Leakage Current				0.2 1	μA
V_{IH}	Digital Input Logic "1" Voltage		$0.70 \times V_+$			V
V_{IL}	Digital Input Logic "0" Voltage				$0.30 \times V_+$	V
I_S	Power Supply Current	No loading (outputs high)		46	60 84	μA
V_{THPSS}	V_{TH} Power Supply Sensitivity (Note 6)	V_+ Ramp Rate = 1.1ms V_+ Step = 2.5V to 4.5V			+400	μV
		V_+ Ramp Rate = 1.1ms V_+ Step = 4.5V to 2.5V	-400			μV

Note 1: Absolute Maximum Ratings indicate limits beyond which damage to the device may occur. Operating Ratings indicate conditions for which the device is intended to be functional, but specific performance is not guaranteed. For guaranteed specifications and the test conditions, see the Electrical Characteristics.

Note 2: Human Body Model, applicable std. MIL-STD-883, Method 3015.7. Machine Model, applicable std. JESD22-A115-A (ESD MM std. of JEDEC) Field-Induced Charge-Device Model, applicable std. JESD22-C101-C (ESD FICDM std. of JEDEC).

Note 3: The maximum power dissipation is a function of $T_{J(MAX)}$, θ_{JA} . The maximum allowable power dissipation at any ambient temperature is $P_D = (T_{J(MAX)} - T_A) / \theta_{JA}$. All numbers apply for packages soldered directly onto a PC board.

Note 4: Typical values represent the most likely parametric norm as determined at the time of characterization. Actual typical values may vary over time and will also depend on the application and configuration. The typical values are not tested and are not guaranteed on shipped production material.

Note 5: Limits are 100% production tested at 25°C. Limits over the operating temperature range are guaranteed through correlations using the Statistical Quality Control (SQC) method.

Note 6: V_{TH} Power Supply Sensitivity is defined as the temporary shift in the internal voltage reference due to a step on the V+ pin.

Connection Diagram

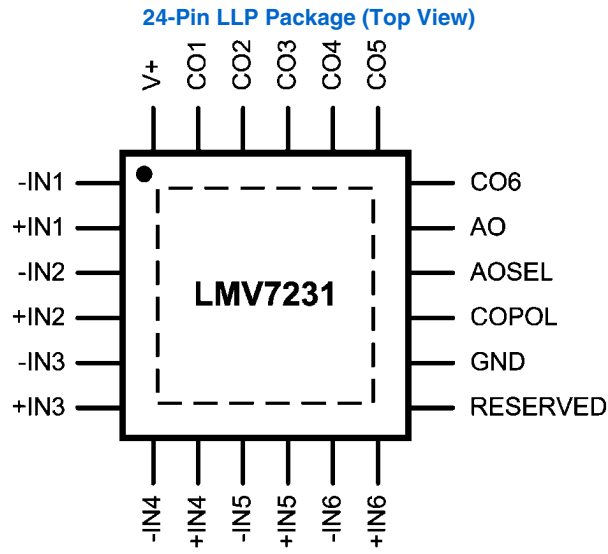

Pin Descriptions

Pin	Symbol	Type	Description
1	-IN1	Analog Input	Negative input for window comparator 1.
2	+IN1	Analog Input	Positive input for window comparator 1.
3	-IN2	Analog Input	Negative input for window comparator 2.
4	+IN2	Analog Input	Positive input for window comparator 2.
5	-IN3	Analog Input	Negative input for window comparator 3.
6	+IN3	Analog Input	Positive input for window comparator 3.
7	-IN4	Analog Input	Negative input for window comparator 4.
8	+IN4	Analog Input	Positive input for window comparator 4.
9	-IN5	Analog Input	Negative input for window comparator 5.
10	+IN5	Analog Input	Positive input for window comparator 5.
11	-IN6	Analog Input	Negative input for window comparator 6.
12	+IN6	Analog Input	Positive input for window comparator 6.
13	RESERVED	Digital Input	Connect to GND.
14	GND	Power	Ground reference pin for the power supply voltage.
15	COPOL	Digital Input	The state of this pin determines whether the CO1-CO6 pins are active "HIGH" or "LOW". When tied LOW the CO1-CO6 outputs will go LOW to indicate an out of window comparison.
16	AOSEL	Digital Input	The state of this pin determines whether the AO pin is active on an over-voltage or under-voltage event. When tied LOW the AO output will be active upon an over-voltage event.
17	AO	Open-Drain NMOS Digital Output	This output is the ANDED combination of either the over-voltage comparator outputs or the under-voltage comparator outputs and is controlled by the state of the AOSEL. AO pin is active "LOW".
18	CO6	Open-Drain NMOS Digital Output	Window comparator 6 NMOS open-drain output.
19	CO5	Open-Drain NMOS Digital Output	Window comparator 5 NMOS open-drain output.
20	CO4	Open-Drain NMOS Digital Output	Window comparator 4 NMOS open-drain output.
21	CO3	Open-Drain NMOS Digital Output	Window comparator 3 NMOS open-drain output.
22	CO2	Open-Drain NMOS Digital Output	Window comparator 2 NMOS open-drain output.
23	CO1	Open-Drain NMOS Digital Output	Window comparator 1 NMOS open-drain output.
24	V+	Power	Power supply pin.
DAP	DAP	Thermal Pad	Die Attach Paddle (DAP) connect to GND.

Ordering Information

Package	Part Number	Package Marking	Transport Media	NSC Drawing
24-Pin LLP NOPB	LMV7231SQ	L7231SQ	1000 Units Tape and Reel	SQA24A
	LMV7231SQE		250 Units Tape and Reel	
	LMV7231SQX		4500 Units Tape and Reel	

Block Diagram

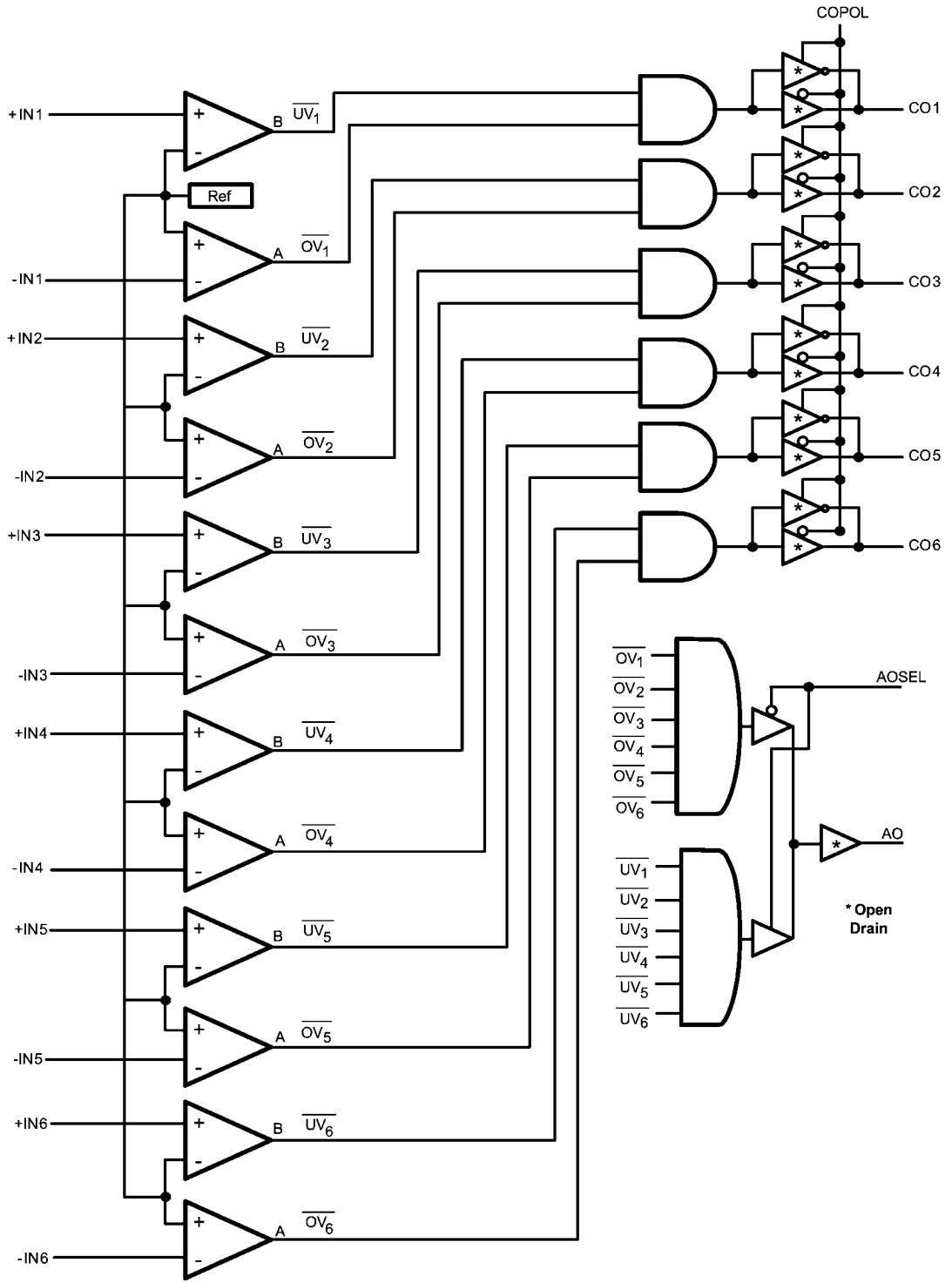

30114943

Typical Performance Characteristics

$V^+ = 3.3V$ and $T_A = 25^\circ C$ unless otherwise noted.

+In Input Rising Threshold Distribution

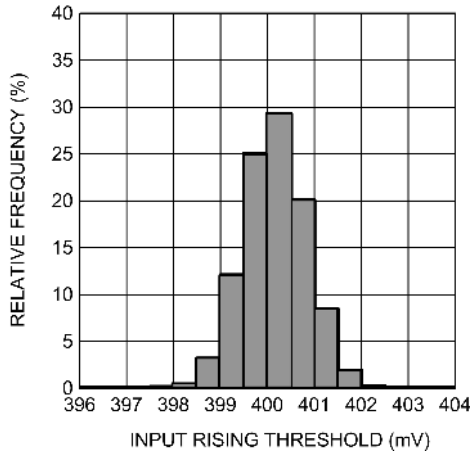

30114976

-In Input Rising Threshold Distribution

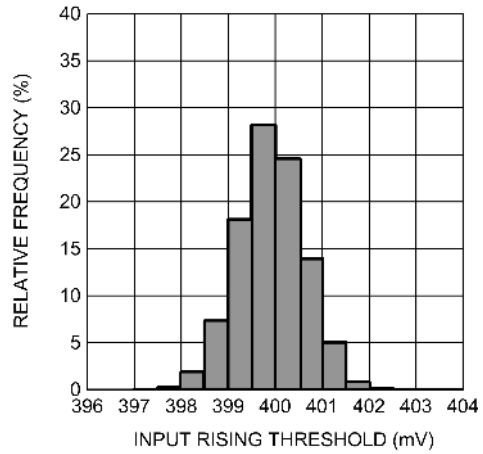

30114979

+In Input Falling Threshold Distribution

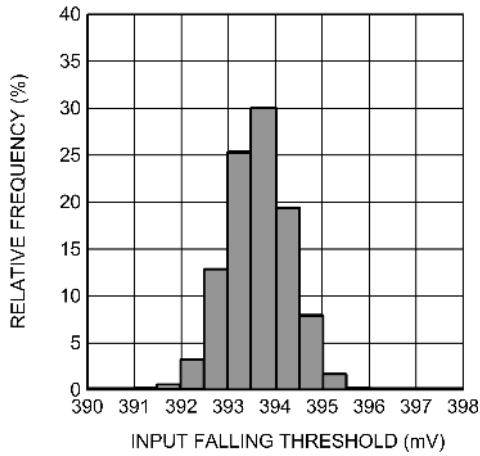

30114977

-In Input Falling Threshold Distribution

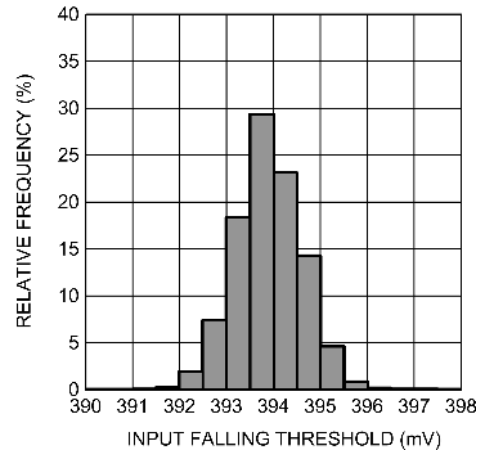

30114980

+In Hysteresis Distribution

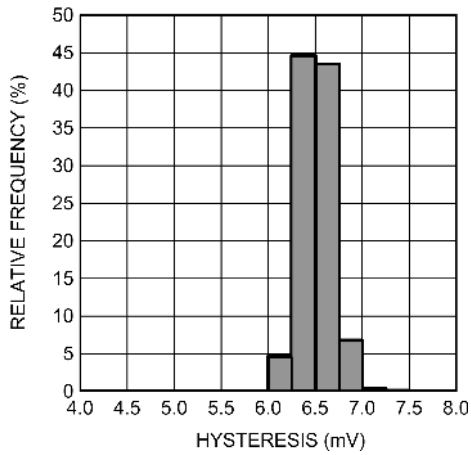

30114978

-In Hysteresis Distribution

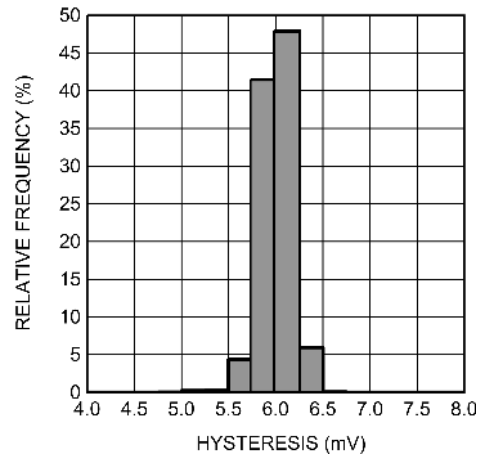

30114981

Input Rising Threshold Voltage vs. Temperature

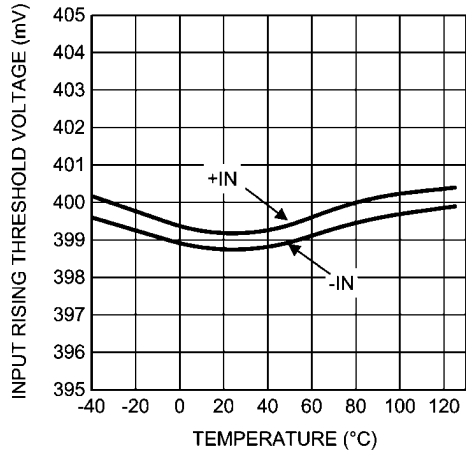

30114946

Input Rising Threshold Voltage vs. Supply Voltage

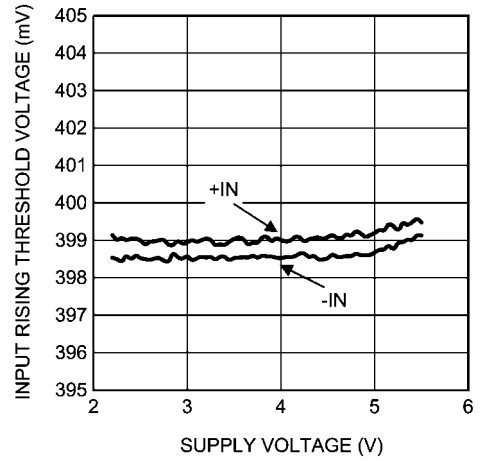

30114947

Input Falling Threshold Voltage vs. Temperature

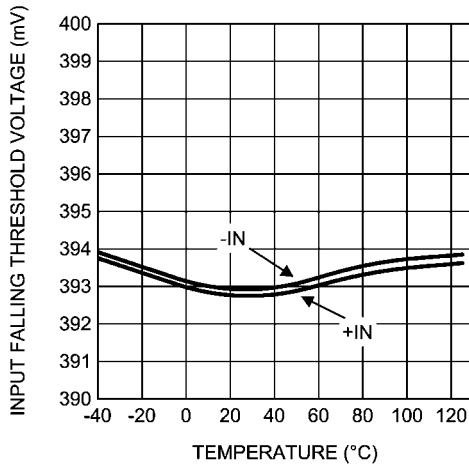

30114948

Input Falling Threshold Voltage vs. Supply Voltage

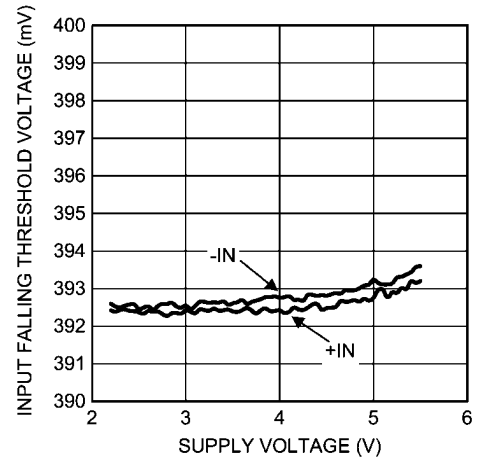

30114949

Hysteresis vs. Temperature

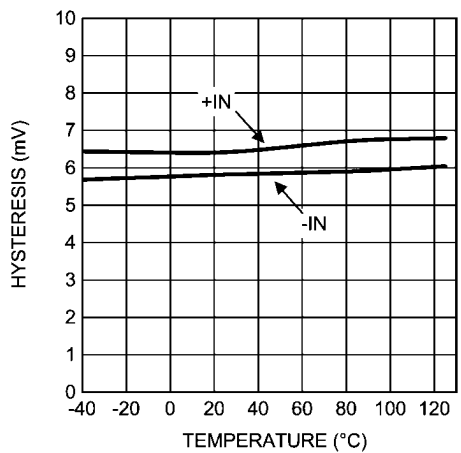

30114950

Hysteresis vs. Supply Voltage

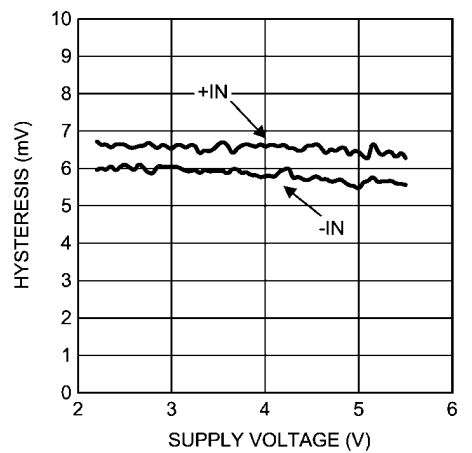

30114951

Supply Current vs. Supply Voltage and Temperature

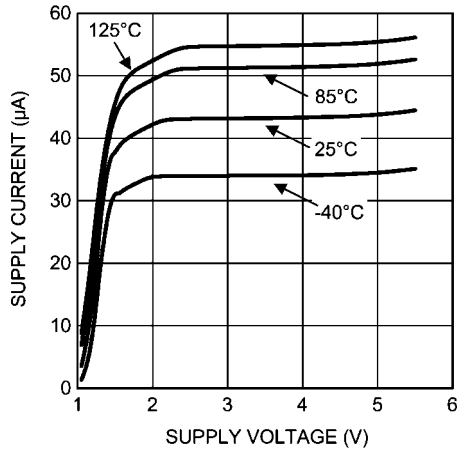

30114952

Supply Current vs. Output Sink Current

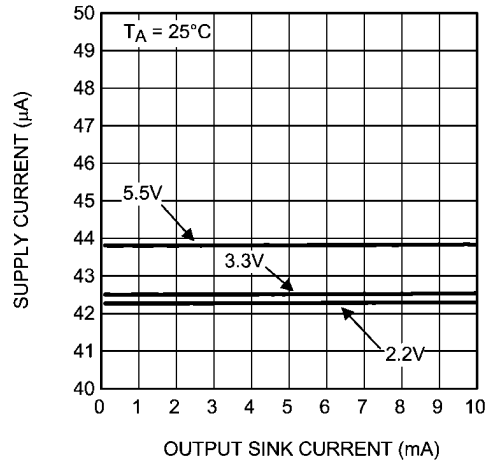

30114971

Supply Current vs. Output Sink Current

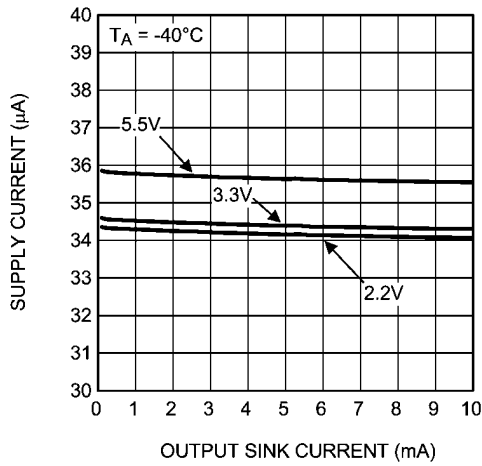

30114972

Supply Current vs. Output Sink Current

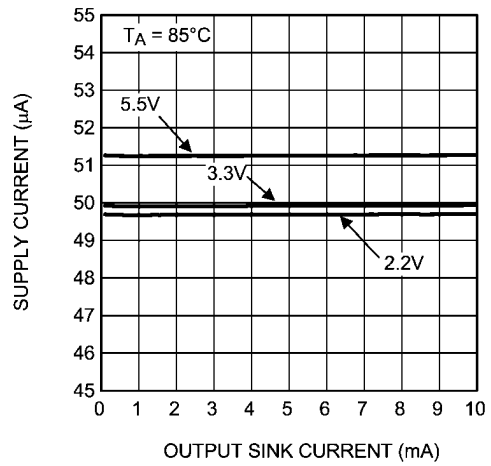

30114973

Supply Current vs. Output Sink Current

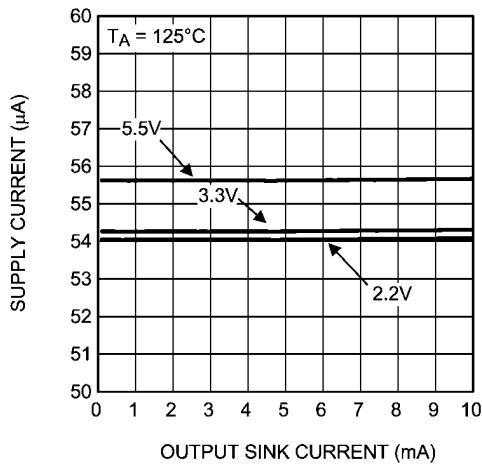

30114974

Bias Current vs. Input Voltage

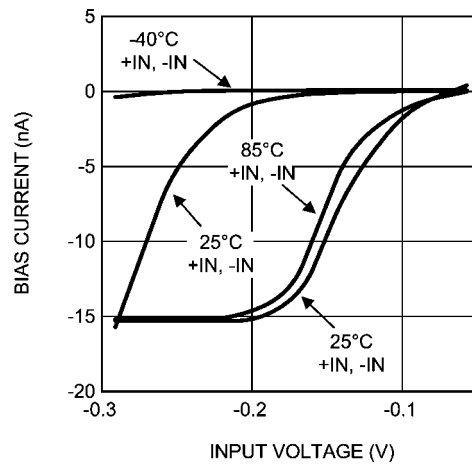

30114961

Bias Current vs. Input Voltage

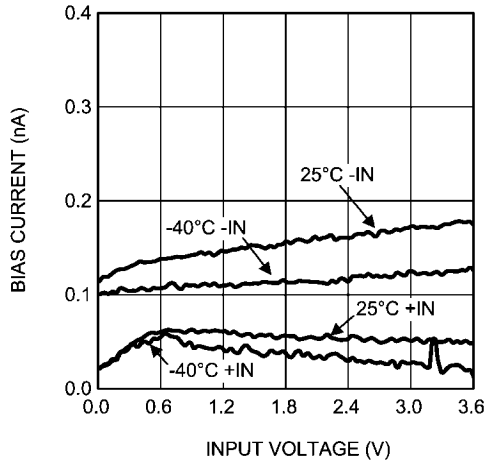

30114962

Bias Current vs. Input Voltage

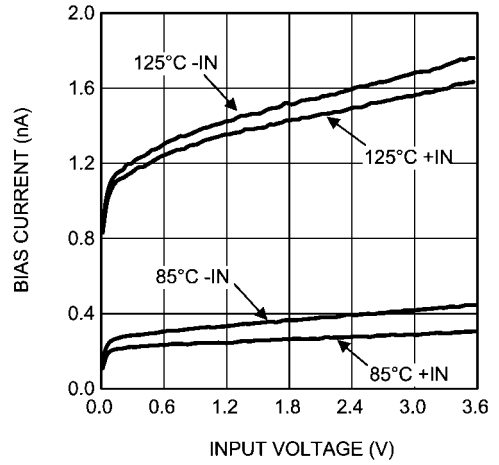

30114963

Output Voltage Low vs. Output Sink Current

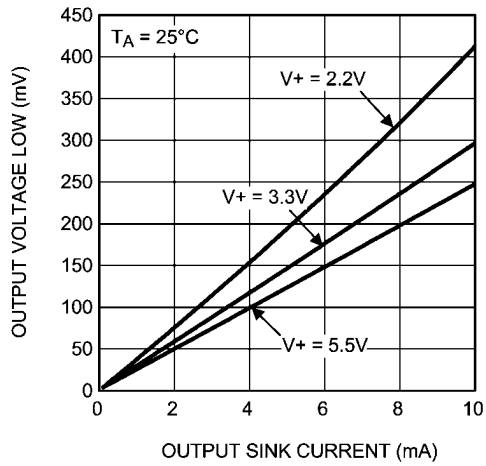

30114964

Output Voltage Low vs. Output Sink Current

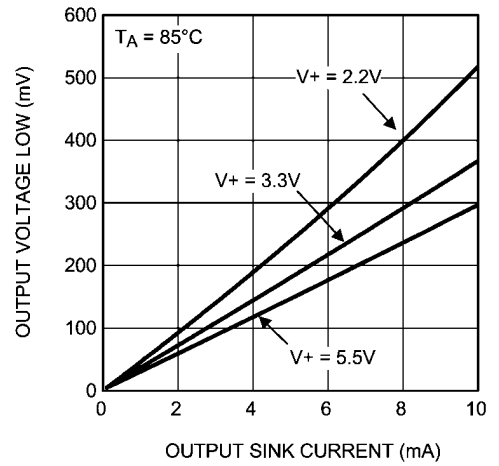

30114965

Output Voltage Low vs. Output Sink Current

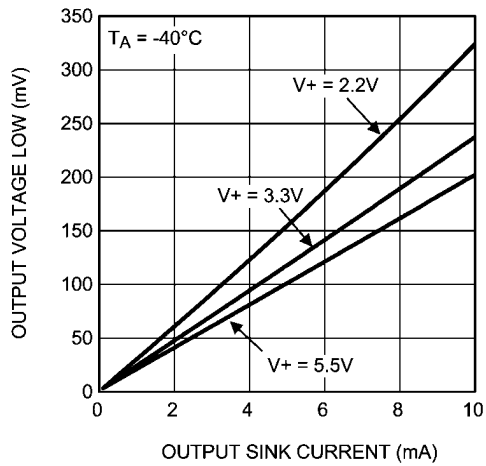

30114966

Output Voltage Low vs. Output Sink Current

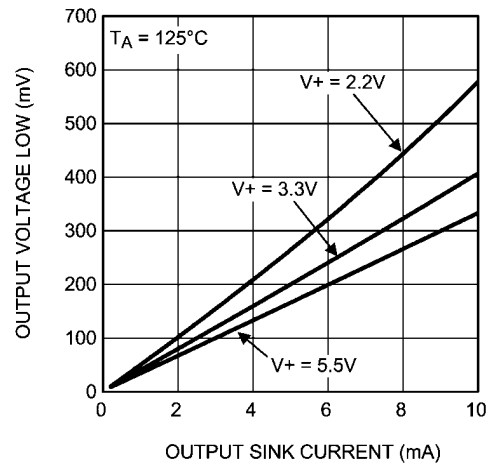

30114967

Output Short Circuit Current vs. Output Voltage

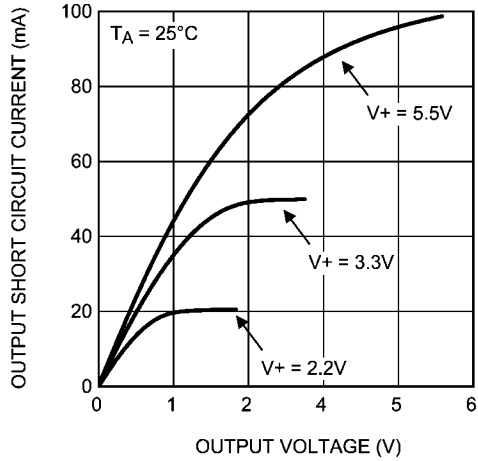

30114968

Output Short Circuit Current vs. Output Voltage

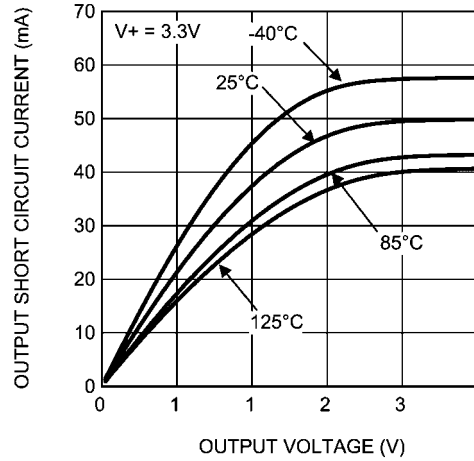

30114969

Propagation Delay vs. Input Overdrive

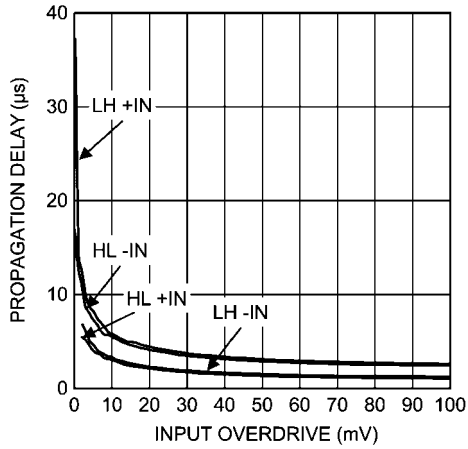

30114960

Rise and Fall Times vs. Output Pull-Up Resistor

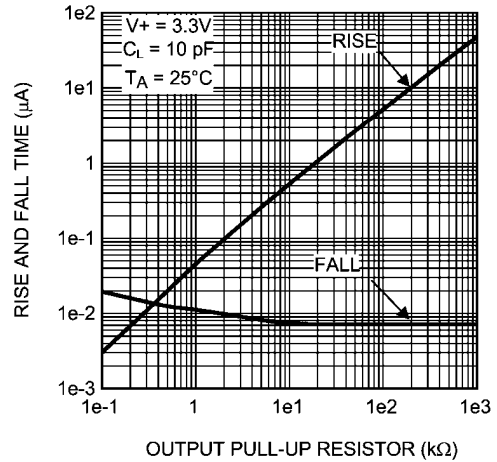

30114970

Propagation Delay

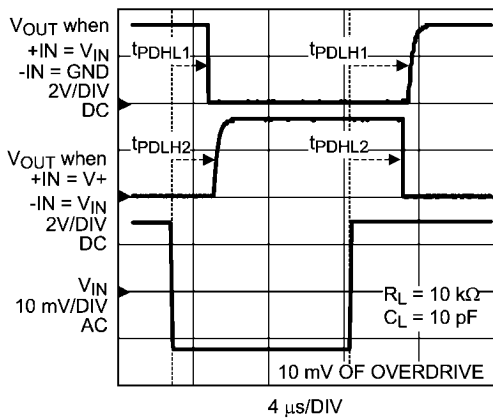

30114975

Output Leakage Current vs. Output Voltage

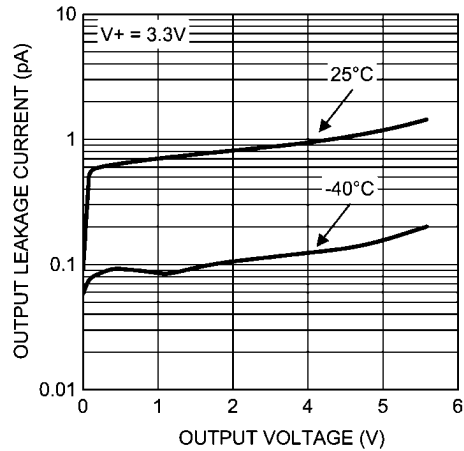

30114984

Output Leakage Current vs. Output Voltage

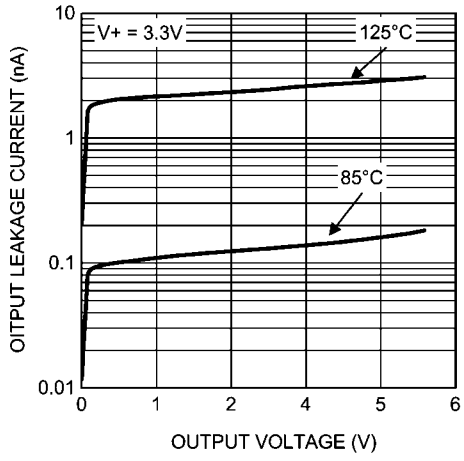

30114985

Application Information

3 RESISTOR VOLTAGE DIVIDER SELECTION

The LMV7231 trip points can be set by external resistor dividers as shown in Figure 1

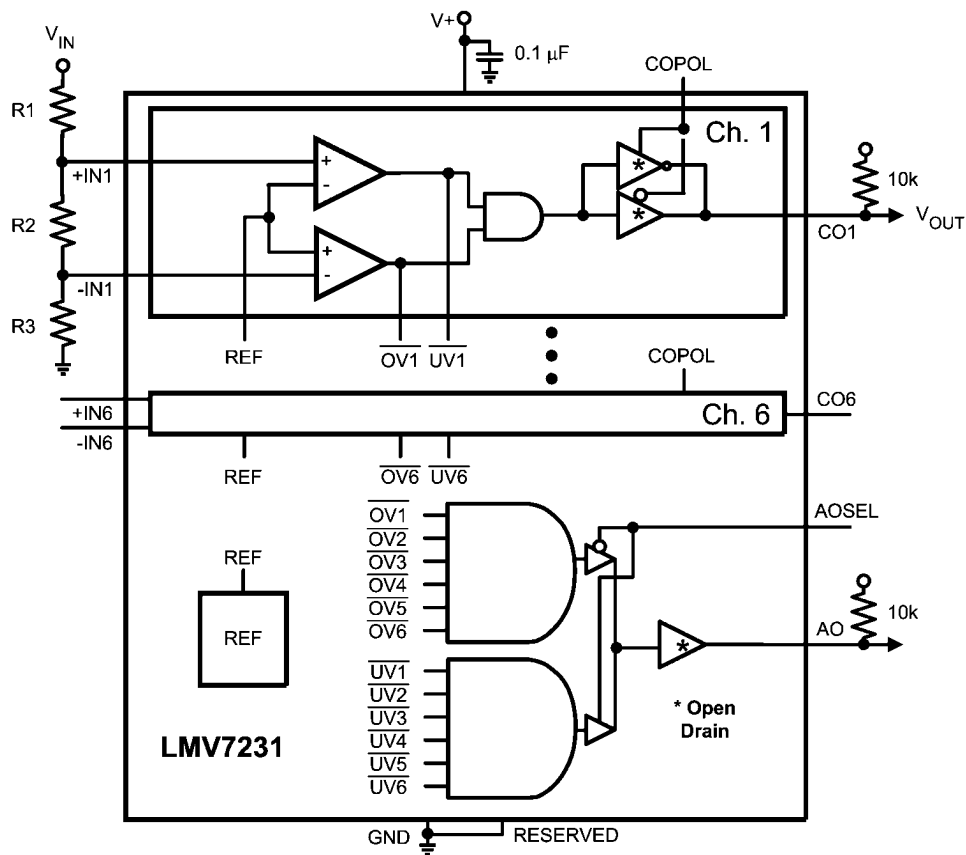

30114953

FIGURE 1. External Resistor Dividers

Each trip point, over-voltage, V_{OV} , and under-voltage, V_{UV} , can be optimized for a falling supply, V_{THF} , or a rising supply, V_{THR} . Therefore there are $2^2 = 4$ different optimization cases. Exiting the voltage detection window (Figure 2), entering the window (Figure 3), rising into and out of the window (Figure 4), falling into and out of the window (Figure 5). Note that for each case each trip point can be optimized for either a rising or falling signal, not both. The governing equations make it such that if the same resistor, R3, and over/under-voltage ratio, V_{OV}/V_{UV} , is used across the channels the same nominal current will travel through the resistor ladder. As a result R2 will also be the same across channels and only R1 needs to change to set voltage detection window maximizing reuse of resistor values and minimizing design complexity. Select the R3 resistor value to be below 100k Ω so the current through the divider ladder is much greater than the LMV7231 bias current. If the current traveling through the resistor divider is on the same magnitude of the LMV7231 I_{BIAS} , the I_{BIAS} current will create error in your circuit and cause trip voltage shifts. Keep in mind the greatest error due to I_{BIAS} will be caused when that current passes through the greatest equivalent resistance, $R_{EQ} = R1(R2+R3)$, which will be seen by the positive input of the window comparator, +IN.

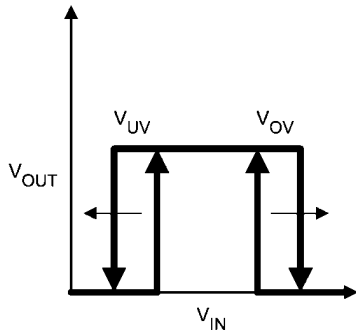

R3 set

$$R2 = R3((V_{THF}/V_{THR})V_{OV}/V_{UV} - 1)$$

$$R1 = R3((1/V_{THR})V_{OV} - (V_{THF}/V_{THR})V_{OV}/V_{UV})$$

Ex. $V_{OV} = 3.465V$, $V_{UV} = 3.135V$, i.e. $V_{RANGE} = 3.3V \pm 5\%$

R3 set to 10 kΩ

$$R2 = 10k((0.394/0.4)3.465/3.135 - 1) \approx 887\Omega$$

$$R1 = 10k((1/0.4)3.465 - (0.394/0.4)3.465/3.135) \approx 75\text{ k}\Omega$$

30114954

FIGURE 2. Exiting the Voltage Detection Window

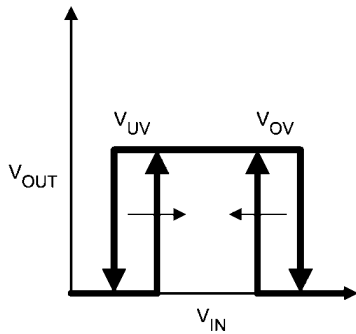

R3 set

$$R2 = R3((V_{THR}/V_{THF})V_{OV}/V_{UV} - 1)$$

$$R1 = R3((1/V_{THF})V_{OV} - (V_{THR}/V_{THF})V_{OV}/V_{UV})$$

Ex. $V_{OV} = 3.465V$, $V_{UV} = 3.135V$, i.e. $V_{RANGE} = 3.3V \pm 5\%$

R3 set to 10 kΩ

$$R2 = 10k((0.4/0.394)3.465/3.135 - 1) \approx 1.21\text{ k}\Omega$$

$$R1 = 10k((1/0.394)3.465 - (0.4/0.394)3.465/3.135) \approx 76.8\text{ k}\Omega$$

30114955

FIGURE 3. Entering the Voltage Detection Window

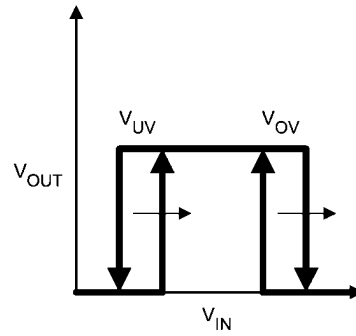

R3 set

$$R2 = R3(V_{OV}/V_{UV} - 1)$$

$$R1 = R3((1/V_{THR})V_{OV} - V_{OV}/V_{UV})$$

Ex. $V_{OV} = 3.465V$, $V_{UV} = 3.135V$, i.e. $V_{RANGE} = 3.3V \pm 5\%$

R3 set to 10 kΩ

$$R2 = 10k((3.465/3.135) - 1) \approx 1.05\text{ k}\Omega$$

$$R1 = 10k((1/0.4)3.465 - 3.465/3.135) \approx 75\text{ k}\Omega$$

30114956

FIGURE 4. Rising Into and Out Of the Voltage Detection Window

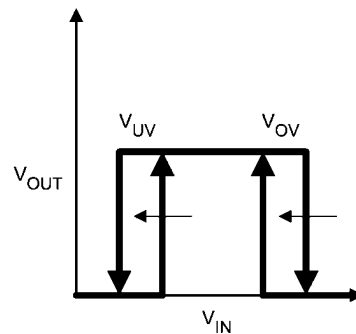

R3 set

$$R2 = R3(V_{OV}/V_{UV} - 1)$$

$$R1 = R3((1/V_{THF})V_{OV} - V_{OV}/V_{UV})$$

Ex. $V_{OV} = 3.465V$, $V_{UV} = 3.135V$, i.e. $V_{RANGE} = 3.3V \pm 5\%$

R3 set to 10 kΩ

$$R2 = 10k((3.465/3.135) - 1) \approx 1.05\text{ k}\Omega$$

$$R1 = 10k((1/0.394)3.465 - 3.465/3.135) \approx 76.8\text{ k}\Omega$$

30114957

FIGURE 5. Falling Into and Out Of the Voltage Detection Window

INPUT/OUTPUT VOLTAGE RANGE ABOVE V+

The LMV7231 Hex Window Comparator with 1.5% precision can accurately monitor up to 6 power rails or batteries at one time. The input and output voltages of the device can exceed the supply voltage, V+, of the comparator, and can be up to the absolute maximum ratings without causing damage or performance degradation. The typical μC input pin with crowbar diode ESD protection circuitry will not allow the input to go above V+, and thus its usefulness is limited in power supply supervision applications.

The supply independent inputs of the window comparator blocks allow the LMV7231 to be tolerant of system faults. For example if the power is suddenly removed from the LMV7231 due to a system malfunction yet there still exists a voltage on the input, this will not be an issue as long as the monitored input voltage does not exceed absolute maximum ratings. Another example where this feature comes in handy is a battery sense application such as the one in Figure 6. The boards may be sitting on the shelf unbiased with V+ grounded, and yet have a fully charged battery on board. If the comparator measuring the battery had crowbar diodes, the diode from –IN to V+ would turn on, sourcing current from the battery eventually draining the battery. However, when using the LMV7231 no current, except the low input bias current of the device, will flow into the chip, and the battery charge will be preserved.

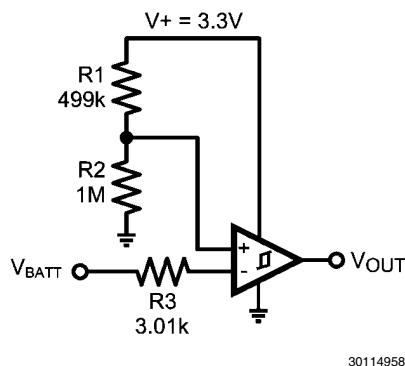

FIGURE 6. Battery Sense Application

The output pin voltages of the device can also exceed the supply voltage, V+, of the comparator. This provides extra flexibility and enables designs which pull up the outputs to higher voltage levels to meet system requirements. For example it's possible to run the LMV7231 at its minimum operating voltage, V+ = +2.2V, but pull up the output up to the absolute maximum ratings to bias a blue LED, with a forward voltage of V_F = +4V.

In a power supply supervision application the hardwired LMV7231 is a sound solution compared to the μC with software alternative for several reasons. First, startup is faster. During startup you don't need to account for code loading time, oscillator ramp time, and reset time. Second, operation is quick. The LMV7231 has a maximum propagation delay in the μs and isn't affected by sampling and conversion delays related to reading data, calculating data, and setting flags. Third, less overhead. The LMV7231 doesn't require an expensive power consuming microcontroller nor is it dependent on controller code which could get damaged or crash.

POWER SUPPLY BYPASSING

Bypass the supply pin, V+, with a 0.1 μF ceramic capacitor placed close to the V+ pin. If transients with rise/fall times of 100's μs and magnitudes of 100's mV are expected on the power supply line a RC low pass filter network as shown in Figure 7 is recommended for additional bypassing. If no such bypass network is used power supply transients can cause the internal voltage reference of the comparator to temporarily shift potentially resulting in a brief incorrect comparator output. For example if an RC network with 100 Ω resistance and 10 μF capacitance (1.1ms rise time) is used the voltage reference will shift temporarily the amount, V_{TH} Power Supply Sensitivity (V_{TH}PSS), specified in the Electrical Characteristics table.

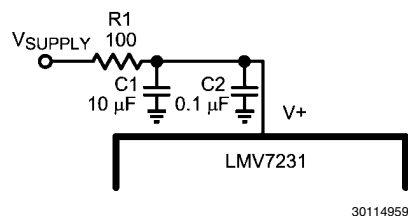

FIGURE 7. Power Supply Bypassing

POWER SUPPLY SUPERVISION

Figure 8 shows a power supply supervision circuit utilizing the LMV7231. This application uses the efficient, easy to use LM25007 step-down switching regulator. This switching regulator can handle a 9V – 42V input voltage range and its regulated output voltage is set to 5V with R2 = R3 = 3k Ω .

$$V_{\text{OUT}} = 2.5 \times (R2 + R3)/R3$$

$$= 2.5 \times (3k + 3k)/3k = 5V$$

Resistor R6 and capacitors C6, C7 are utilized to minimize output ripple voltage per the LM25007 evaluation board application note.

The comparator voltage window is set to 5V +/- 5% by R7=1.15k Ω , R8=10 Ω , R9=95.3 Ω . See [3 RESISTOR VOLTAGE DIVIDER SELECTION](#) section in the Application Information section of the datasheet for details on how to set the comparator voltage window.

With components selected the output ripple voltage seen on the LM25007 is approximately 30 - 35mV and is reduced to about 4mV at the comparator input, +IN1, by the resistor divider. This ripple voltage can be reduced multiple ways. First, user can operate the device in continuous conduction mode rather than discontinuous conduction mode. To do this increase the load current of the device (see LM25007 datasheet for more details). However, make sure not to exceed the power rating of the resistors in the resistor ladder. Second, ripple can be reduced further with a bypass cap, C9, at the resistor divider. If desired a user can select a 1 μF capacitor to achieve less than 3mV ripple at +IN1. However, there is a tradeoff and adding capacitance at this node will lower the system response time.

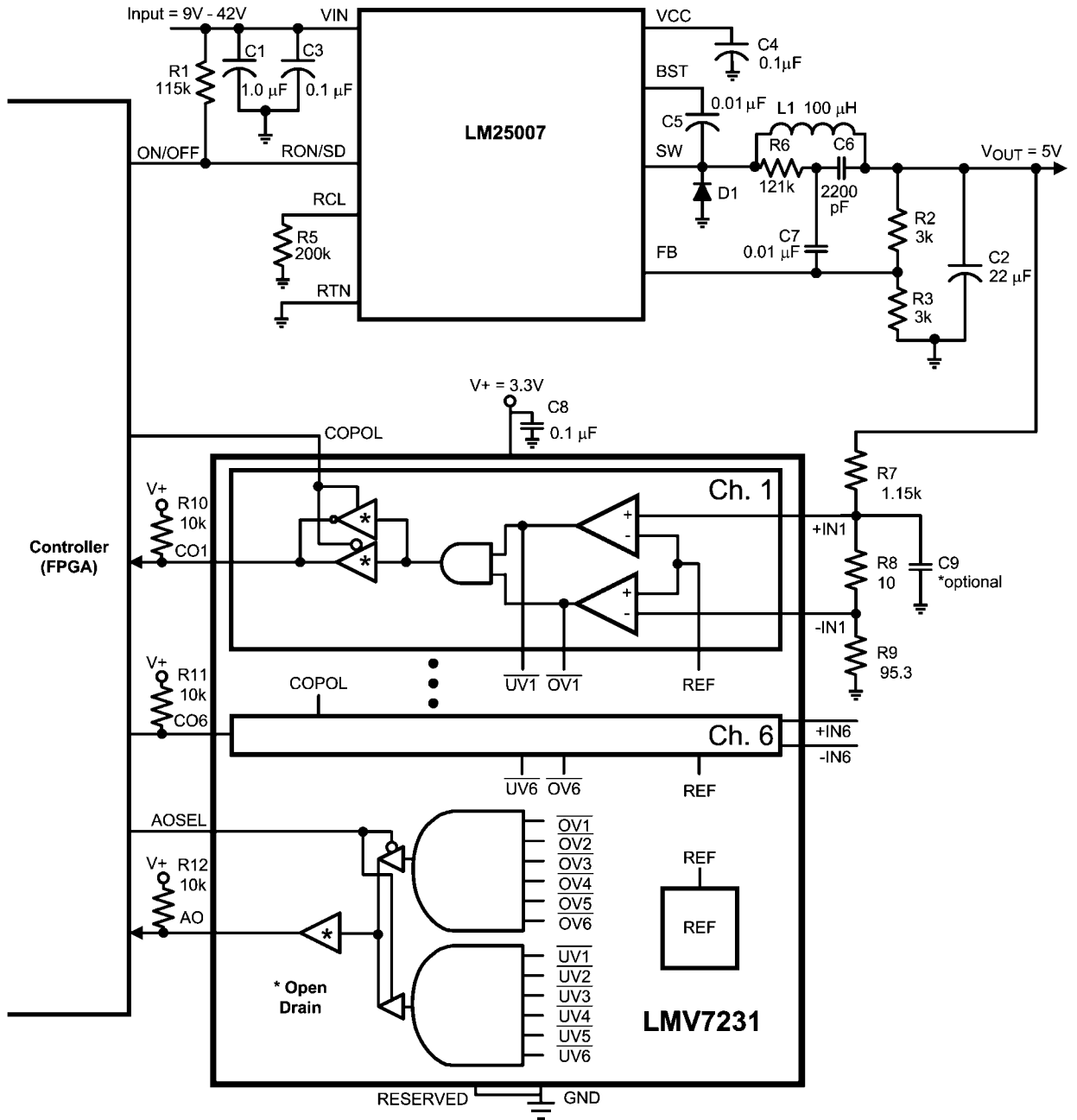

30114944

FIGURE 8. Power Supply Supervision

Physical Dimensions inches (millimeters) unless otherwise noted

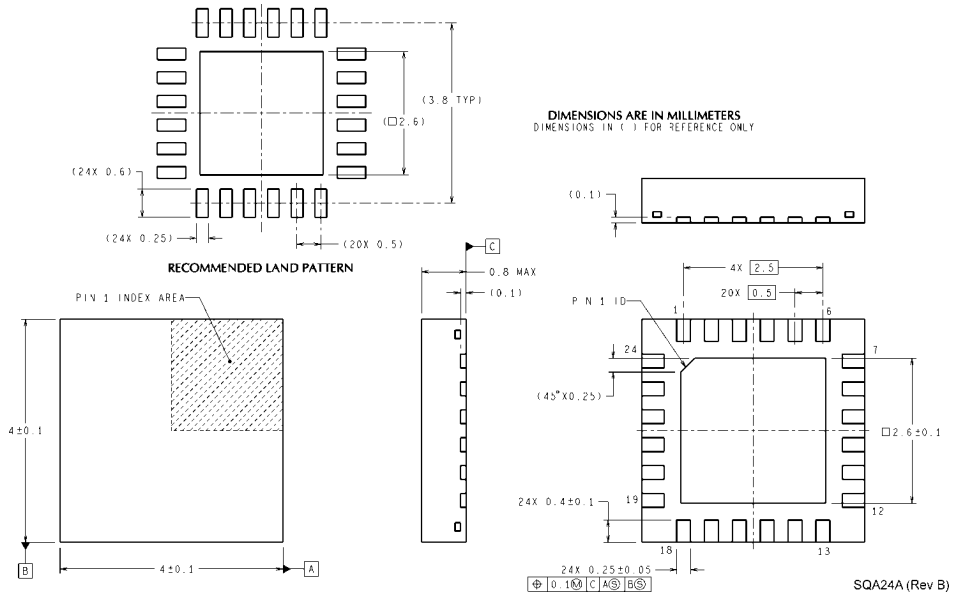

24-Pin LLP Package
NS Package Number SQA24A

For more National Semiconductor product information and proven design tools, visit the following Web sites at:
www.national.com

Products		Design Support	
Amplifiers	www.national.com/amplifiers	WEBENCH® Tools	www.national.com/webench
Audio	www.national.com/audio	App Notes	www.national.com/appnotes
Clock and Timing	www.national.com/timing	Reference Designs	www.national.com/refdesigns
Data Converters	www.national.com/adc	Samples	www.national.com/samples
Interface	www.national.com/interface	Eval Boards	www.national.com/evalboards
LVDS	www.national.com/lvds	Packaging	www.national.com/packaging
Power Management	www.national.com/power	Green Compliance	www.national.com/quality/green
Switching Regulators	www.national.com/switchers	Distributors	www.national.com/contacts
LDOs	www.national.com/ldo	Quality and Reliability	www.national.com/quality
LED Lighting	www.national.com/led	Feedback/Support	www.national.com/feedback
Voltage References	www.national.com/vref	Design Made Easy	www.national.com/easy
PowerWise® Solutions	www.national.com/powerwise	Applications & Markets	www.national.com/solutions
Serial Digital Interface (SDI)	www.national.com/sdi	Mil/Aero	www.national.com/milaero
Temperature Sensors	www.national.com/tempensors	SolarMagic™	www.national.com/solarmagic
PLL/VCO	www.national.com/wireless	PowerWise® Design University	www.national.com/training

THE CONTENTS OF THIS DOCUMENT ARE PROVIDED IN CONNECTION WITH NATIONAL SEMICONDUCTOR CORPORATION ("NATIONAL") PRODUCTS. NATIONAL MAKES NO REPRESENTATIONS OR WARRANTIES WITH RESPECT TO THE ACCURACY OR COMPLETENESS OF THE CONTENTS OF THIS PUBLICATION AND RESERVES THE RIGHT TO MAKE CHANGES TO SPECIFICATIONS AND PRODUCT DESCRIPTIONS AT ANY TIME WITHOUT NOTICE. NO LICENSE, WHETHER EXPRESS, IMPLIED, ARISING BY ESTOPPEL OR OTHERWISE, TO ANY INTELLECTUAL PROPERTY RIGHTS IS GRANTED BY THIS DOCUMENT.

TESTING AND OTHER QUALITY CONTROLS ARE USED TO THE EXTENT NATIONAL DEEMS NECESSARY TO SUPPORT NATIONAL'S PRODUCT WARRANTY. EXCEPT WHERE MANDATED BY GOVERNMENT REQUIREMENTS, TESTING OF ALL PARAMETERS OF EACH PRODUCT IS NOT NECESSARILY PERFORMED. NATIONAL ASSUMES NO LIABILITY FOR APPLICATIONS ASSISTANCE OR BUYER PRODUCT DESIGN. BUYERS ARE RESPONSIBLE FOR THEIR PRODUCTS AND APPLICATIONS USING NATIONAL COMPONENTS. PRIOR TO USING OR DISTRIBUTING ANY PRODUCTS THAT INCLUDE NATIONAL COMPONENTS, BUYERS SHOULD PROVIDE ADEQUATE DESIGN, TESTING AND OPERATING SAFEGUARDS.

EXCEPT AS PROVIDED IN NATIONAL'S TERMS AND CONDITIONS OF SALE FOR SUCH PRODUCTS, NATIONAL ASSUMES NO LIABILITY WHATSOEVER, AND NATIONAL DISCLAIMS ANY EXPRESS OR IMPLIED WARRANTY RELATING TO THE SALE AND/OR USE OF NATIONAL PRODUCTS INCLUDING LIABILITY OR WARRANTIES RELATING TO FITNESS FOR A PARTICULAR PURPOSE, MERCHANTABILITY, OR INFRINGEMENT OF ANY PATENT, COPYRIGHT OR OTHER INTELLECTUAL PROPERTY RIGHT.

LIFE SUPPORT POLICY

NATIONAL'S PRODUCTS ARE NOT AUTHORIZED FOR USE AS CRITICAL COMPONENTS IN LIFE SUPPORT DEVICES OR SYSTEMS WITHOUT THE EXPRESS PRIOR WRITTEN APPROVAL OF THE CHIEF EXECUTIVE OFFICER AND GENERAL COUNSEL OF NATIONAL SEMICONDUCTOR CORPORATION. As used herein:

Life support devices or systems are devices which (a) are intended for surgical implant into the body, or (b) support or sustain life and whose failure to perform when properly used in accordance with instructions for use provided in the labeling can be reasonably expected to result in a significant injury to the user. A critical component is any component in a life support device or system whose failure to perform can be reasonably expected to cause the failure of the life support device or system or to affect its safety or effectiveness.

National Semiconductor and the National Semiconductor logo are registered trademarks of National Semiconductor Corporation. All other brand or product names may be trademarks or registered trademarks of their respective holders.

Copyright© 2010 National Semiconductor Corporation

For the most current product information visit us at www.national.com



**National Semiconductor
Americas Technical
Support Center**
Email: support@nsc.com
Tel: 1-800-272-9959

**National Semiconductor Europe
Technical Support Center**
Email: europe.support@nsc.com

**National Semiconductor Asia
Pacific Technical Support Center**
Email: ap.support@nsc.com

**National Semiconductor Japan
Technical Support Center**
Email: jpn.feedback@nsc.com