

Silicon Power Rectifier

1N1183–1N1190, 1N3765–1N3768

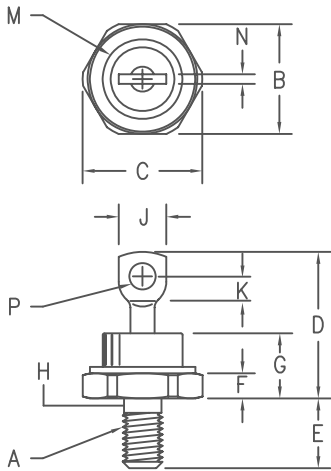

- Notes:
1. Full threads within 2 1/2 threads
 2. Standard Polarity: Stud is Cathode
Reverse Polarity: Stud is Anode

Dim.	Inches		Millimeter		Notes
	Minimum	Maximum	Minimum	Maximum	
A	---	---	---	---	1/4–28
B	.667	.687	16.95	17.44	
C	---	.793	---	20.14	
D	---	1.00	---	25.40	
E	.422	.453	10.72	11.50	
F	.115	.200	2.92	5.08	
G	---	.450	---	11.43	
H	.220	.249	5.59	6.32	1
J	.250	.375	6.35	9.52	
K	.156	---	3.97	---	
M	---	.667	---	16.94	Dia
N	---	.080	---	2.03	
P	.140	.175	3.56	4.44	Dia

D0203AB (D0–5)

JEDEC Numbers	Peak Reverse Voltage
1N1183, 1N1183A	50V
1N1184, 1N1184A	100V
1N1185, 1N1185A	150V
1N1186, 1N1186A	200V
1N1187, 1N1187A	300V
1N1188, 1N1188A	400V
1N1189, 1N1189A	500V
1N1190, 1N1190A	600V
1N3765	700V
1N3766	800V
1N3767	900V
1N3768	1000V

For Reverse Polarity add R to Part Number

- Glass Passivated Die
- 800A surge rating
- Glass to metal construction
- V_{RRM} to 1000V
- Low cost Non–RoHS package

Electrical Characteristics

Average forward current	$I_F(AV)$ 40 Amps	$T_C = 146^\circ C$, half sine wave, $R_{\theta JC} = 1.25^\circ C/W$ 8.3ms, half sine, $T_J = 200^\circ C$
Maximum surge current	I_{FSM} 800 Amps	
Max $I^2 t$ for fusing	$I^2 t$ 2600 A ² s	
Max peak forward voltage	V_{FM} 1.19 Volts	$I_{FM} = 90A; T_J = 25^\circ C^*$
Max peak reverse current	I_{RM} 10 μA	$V_{RRM}, T_J = 25^\circ C$
Max peak reverse current	I_{RM} 2.0 mA	$V_{RRM}, T_J = 150^\circ C$
Max Recommended Operating Frequency	10kHz	

*Pulse test: Pulse width 300 μsec . Duty cycle 2%

Thermal and Mechanical Characteristics

Storage temperature range	T_{STG}	$-65^\circ C$ to $200^\circ C$
Operating junction temp range	T_J	$-65^\circ C$ to $200^\circ C$
Maximum thermal resistance	$R_{\theta JC}$	1.25 $^\circ C/W$ Junction to Case
Mounting torque		25–30 inch pounds
Weight		.5 ounces (14 grams) typical

1N1183-1N1190, 1N3765-1N3768

Figure 1
Typical Forward Characteristics

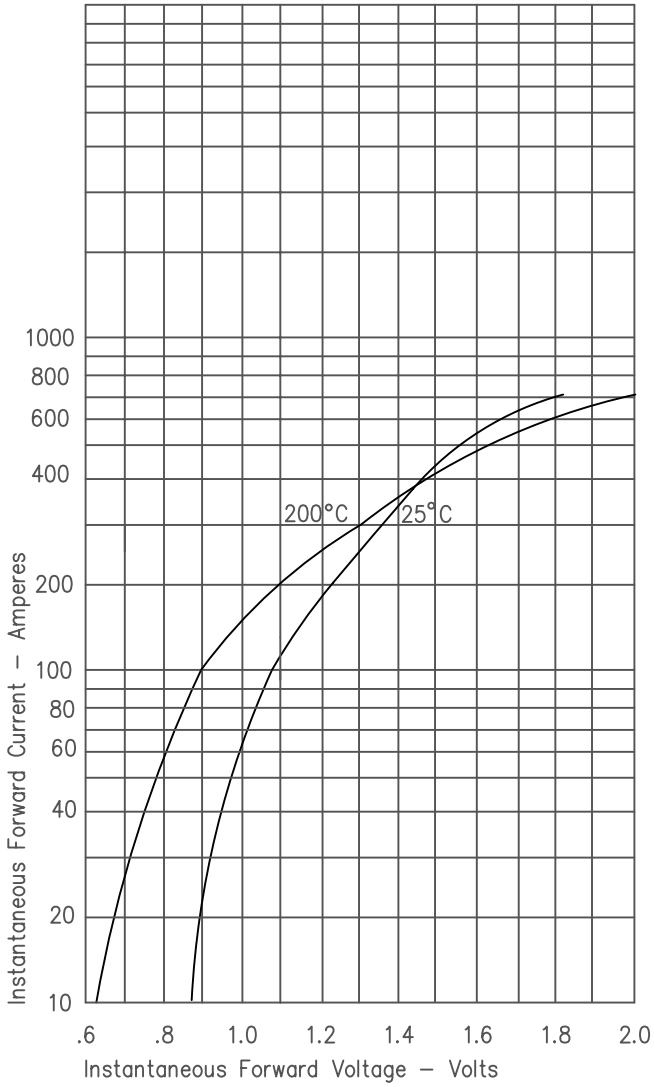

Figure 3
Forward Current Derating

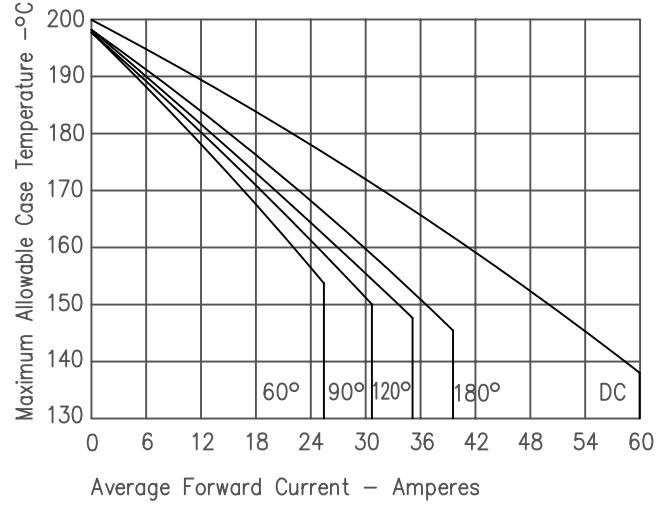

Figure 4
Maximum Forward Power Dissipation

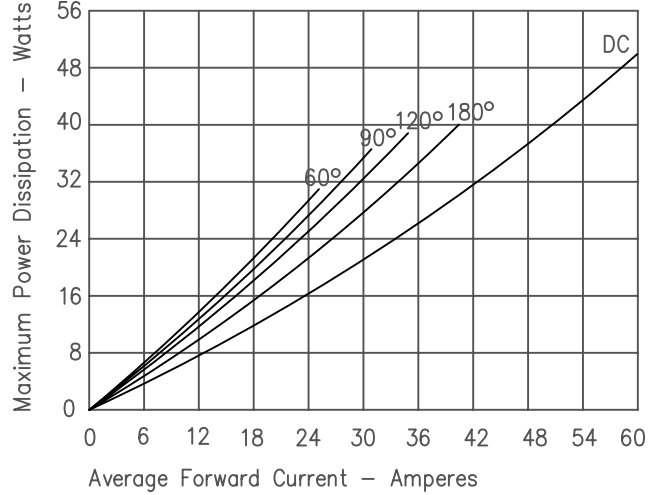

Figure 2
Typical Reverse Characteristics

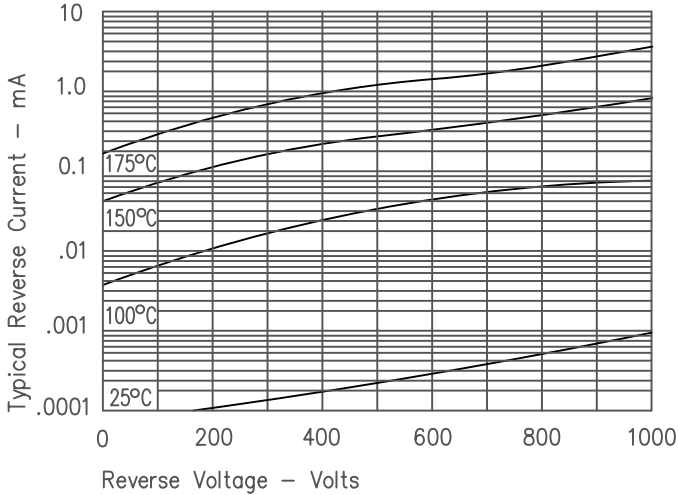

Figure 5
Transient Thermal Impedance

