

REVISIONS					
P	LTR	DESCRIPTION	DATE	DWN	APVD
L		RESIN SUPPLIER CHANGE FOR THE HOUSING	15DEC2021	SCB	KJK

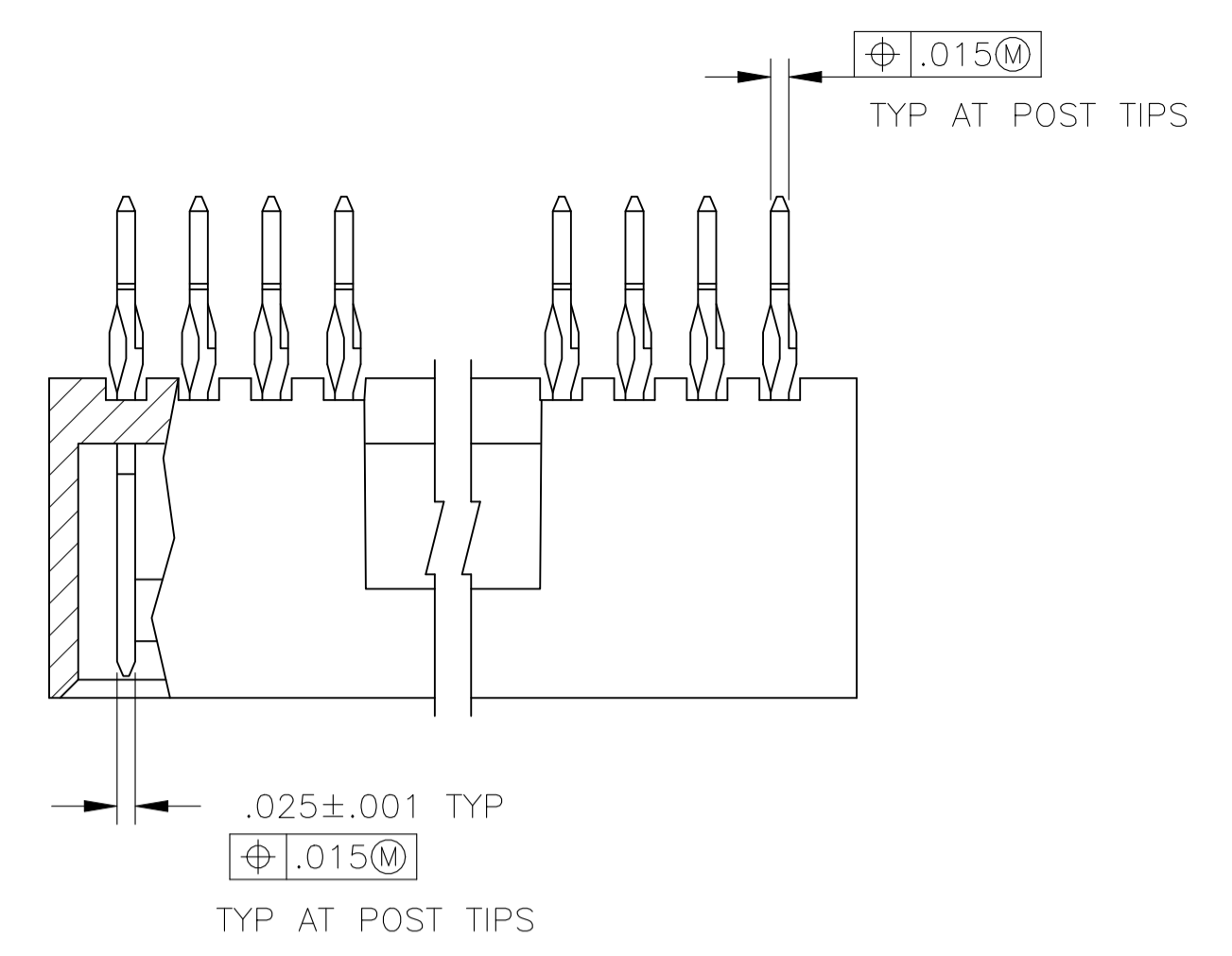

NOTES:

- 1 THE NOTED DIMENSIONS APPLY AT THE INTERSECTION OF THE POST AND HOUSING
- 2 POINT OF MEASUREMENT FOR PLATING THICKNESS
- 3 MATERIAL: HOUSING- FLAME RETARDANT THERMOPLASTIC, COLOR-BLACK
POSTS- COPPER ALLOY
- 4 FINISH: POSTS- .000030 GOLD ON CONTACT AREA,
.000100-.000200 MATTE TIN-LEAD ON SOLDERTAIL,
ALL OVER .000050 NICKEL
- 5 FINISH: POSTS- .000030 GOLD ON CONTACT AREA,
.000100-.000200 MATTE TIN ON SOLDERTAIL,
ALL OVER .000050 NICKEL
- 6 OBSOLETE PARTS: OBSOLETE CIS STREAMLINING PER D.RENAUD/D.SINISI

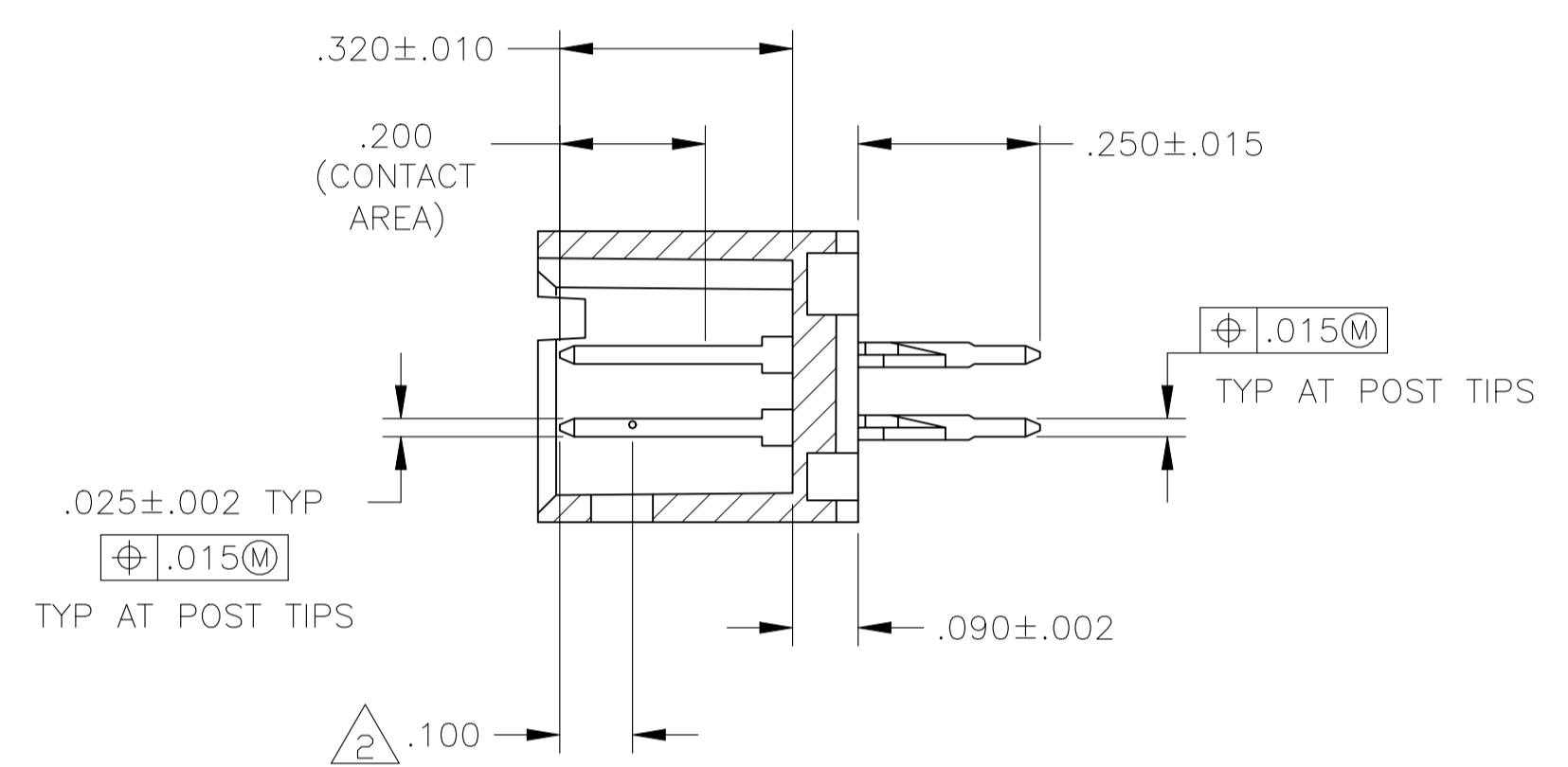
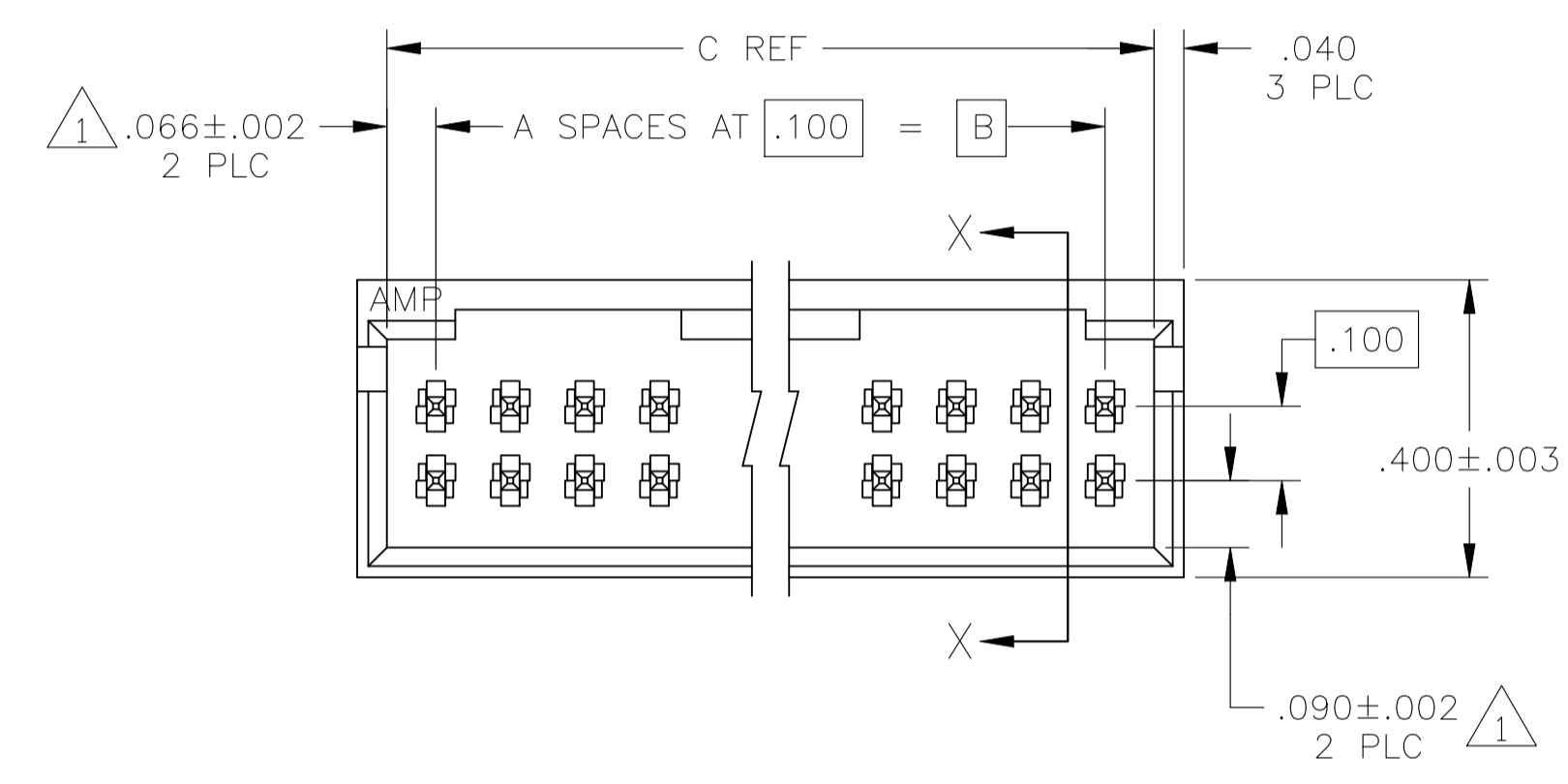

SECTION X-X

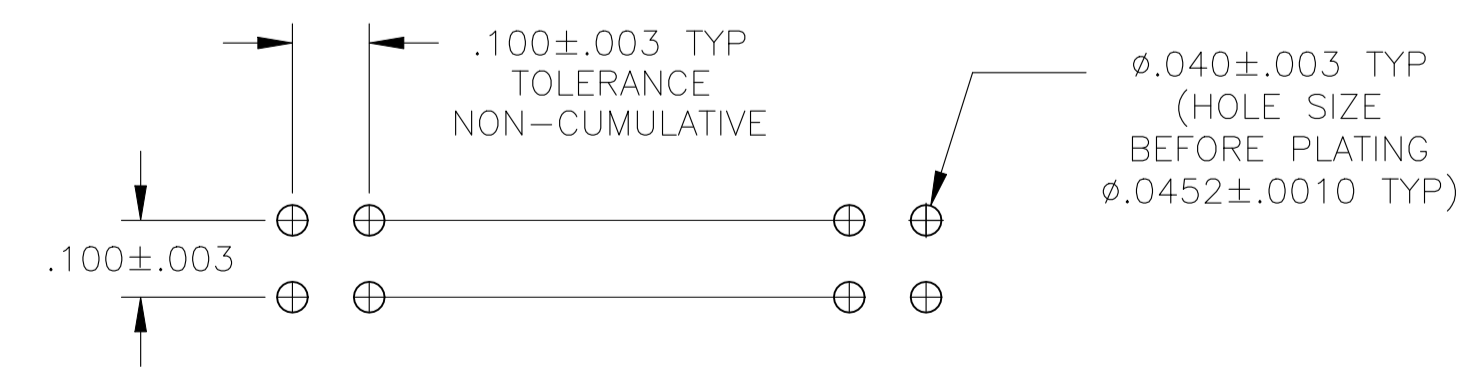
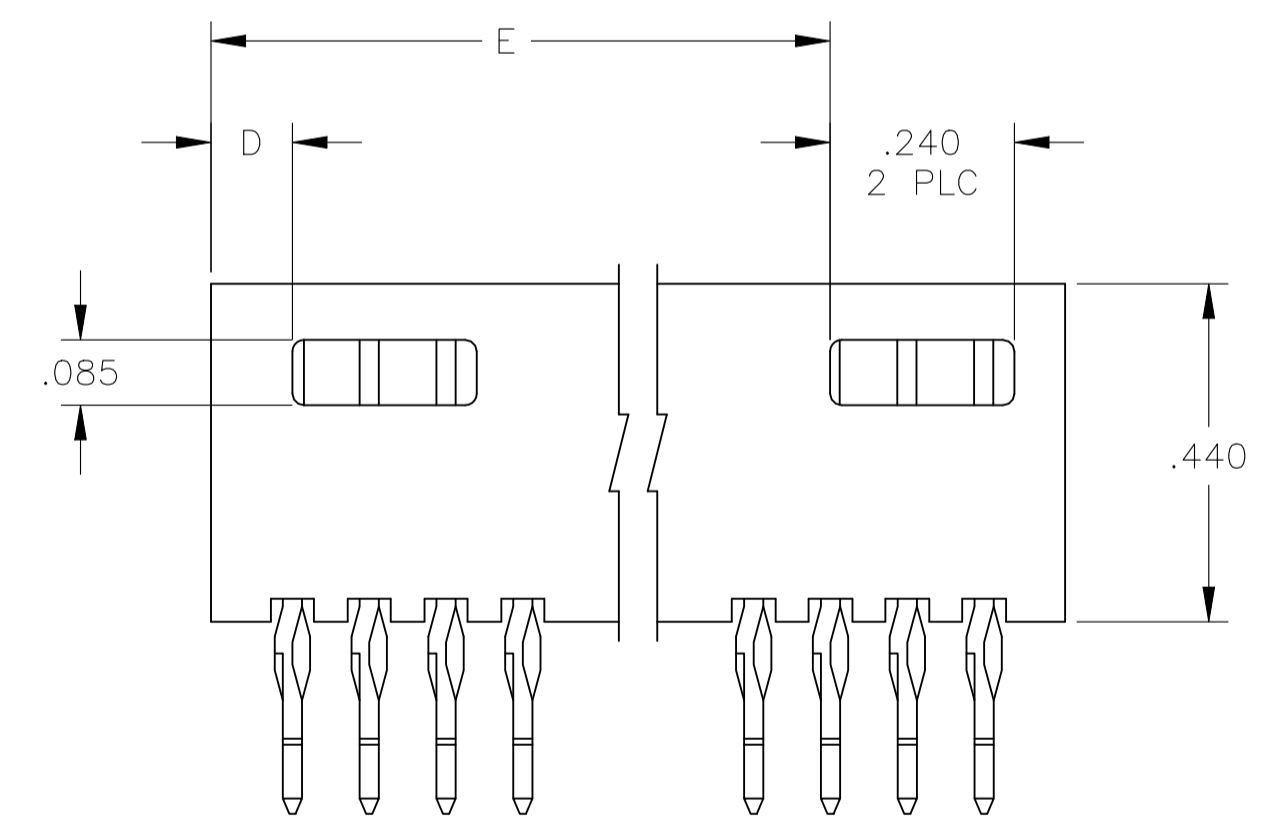

RECOMMENDED HOLE LAYOUT

FINISH	E	D	C	B	A	NO OF POSN	ASSEMBLY PART NUMBER
6 OBSOLETE	2.806	.106	3.032	2.900	29	60	7-102699-8
2.306	.106	2.532	2.400	24	50	7-102699-3	
1.806	.106	2.032	1.900	19	40	6-102699-9	
1.506	.106	1.732	1.600	16	34	6-102699-6	
1.306	.106	1.532	1.400	14	30	6-102699-4	
1.106	.106	1.332	1.200	12	26	6-102699-2	
1.006	.106	1.232	1.100	10	24	6-102699-1	
.806	.106	1.032	.900	9	20	5-102699-9	
---	.406	.932	.800	8	18	5-102699-8	
---	.306	.832	.700	7	16	5-102699-7	
---	.306	.732	.600	6	14	5-102699-6	
---	.206	.632	.500	5	12	5-102699-5	
---	.206	.532	.400	4	10	5-102699-4	
---	.106	.432	.300	3	8	5-102699-3	
---	.106	.332	.200	2	6	5-102699-2	
6 OBSOLETE	2.806	.106	3.032	2.900	29	60	2-102699-8
OBSOLETE	2.706	.106	2.932	2.800	28	58	2-102699-7
OBSOLETE	2.606	.106	2.832	2.700	27	56	2-102699-6
OBSOLETE	2.506	.106	2.732	2.600	26	54	2-102699-5
OBSOLETE	2.406	.106	2.632	2.500	25	52	2-102699-4
OBSOLETE	2.306	.106	2.532	2.400	24	50	2-102699-3
OBSOLETE	2.206	.106	2.432	2.300	23	48	2-102699-2
OBSOLETE	2.106	.106	2.332	2.200	22	46	2-102699-1
OBSOLETE	1.906	.106	2.132	2.000	20	42	2-102699-0
OBSOLETE	1.806	.106	2.032	1.900	19	40	1-102699-9
OBSOLETE	1.706	.106	1.932	1.800	18	38	1-102699-8
OBSOLETE	1.606	.106	1.832	1.700	17	36	1-102699-7
6 SUP BY 6-102699-6	1.506	.106	1.732	1.600	16	34	1-102699-6
OBSOLETE	1.406	.106	1.632	1.500	15	32	1-102699-5
OBSOLETE	1.306	.106	1.532	1.400	14	30	1-102699-4
OBSOLETE	1.206	.106	1.432	1.300	13	28	1-102699-3
OBSOLETE	1.106	.106	1.332	1.200	12	26	1-102699-2
OBSOLETE	1.006	.106	1.232	1.100	11	24	1-102699-1
OBSOLETE	.906	.106	1.132	1.000	10	22	1-102699-0
OBSOLETE	.806	.106	1.032	.900	9	20	102699-9
OBSOLETE	---	.406	.932	.800	8	18	102699-8
OBSOLETE	---	.306	.832	.700	7	16	102699-7
OBSOLETE	---	.306	.732	.600	6	14	102699-6
OBSOLETE	---	.206	.632	.500	5	12	102699-5
OBSOLETE	---	.206	.532	.400	4	10	102699-4
OBSOLETE	---	.106	.432	.300	3	8	102699-3
OBSOLETE	---	.106	.332	.200	2	6	102699-2
OBSOLETE	2.006	.106	2.232	2.100	21	44	102699-1

THIS DRAWING IS A CONTROLLED DOCUMENT.

DIN R BROWN 14APR05
CHK R BROWN 14APR05
APVD J GEFORD 14APR05

TE Connectivity

HDR ASSY, MOD II, COMPLIANT
PIN, DBL ROW, .100x.100 CL,
4 SIDE SHROUD

SIZE: A1 CAGE CODE: 00779 DRAWING NO: 102699
WEIGHT: --

CUSTOMER DRAWING SCALE: 4:1 SHEET 1 OF 1 REV L