

REVISIONS				
P	LTR	DESCRIPTION	DATE	APP'D
E4	ECR-18-009229		25SEP2018	DHC PO

MATERIALS			
NO.	COMPONENT NAME	BASE MATERIAL	FINISH
1	Housing	Epoxy Resin, UL94 V-0, Green or Blue	
2	End terminal	silver clad copper alloy	5 microinches min. gold
3	Center terminal	copper alloy	5 microinches min. gold
4	Rocker contact	silver clad copper alloy	5 microinches min. gold
5	Actuator	Phenol resin, UL94 HB, black	
6	Plunger	stainless steel	
7	Spring	music wire	
8	Toggle	brass	chrome or nickel
9	Retainer	Polyamide, UL94 HB, black	
10	Frame	cold rolled steel	zinc or nickel
11	Bushing	brass	100 microinches min. nickel over 10 microinches min. copper
12	Mounting nuts (2)	brass	200 microinches min. bright nickel
13	Locating ring	cold rolled steel	zinc or nickel
14	Internal tooth lockwasher	steel	zinc or nickel

SPECIFICATIONS-SEE NOTE 3				
CURRENT RATING UL & CSA	6A @ 125 VAC (resistive)			
	3A @ 250 VAC (resistive)			
	4A @ 28 VDC (resistive)			
TERMINATION RESISTANCE	20 milliohms max @ 2-4 VDC, 1A			
INSULATION RESISTANCE	1,000 megohms min.			
WITHSTANDING VOLTAGE	1,000 VAC			
TRAVEL	24 +/-6 degrees			
ACTUATION FORCE	.05 to 1.5 kgf			
OPERATING TEMPERATURE	-20C to +85C			
STORAGE TEMPERATURE	-40C to +85C			
CONTACT TIMING	break before make			
TERMINAL SEAL	epoxy or insert molded			
DURABILITY	PARAMETER	2 POSITION	3 POSITION	MOMENTARY
	mechanical (no load)	150,000	100,000	80,000
	250 VAC (3A resistive)	80,000	60,000	60,000
	125 VAC (6A resistive)	80,000	60,000	60,000
	28 VDC (4A resistive)	60,000	50,000	40,000

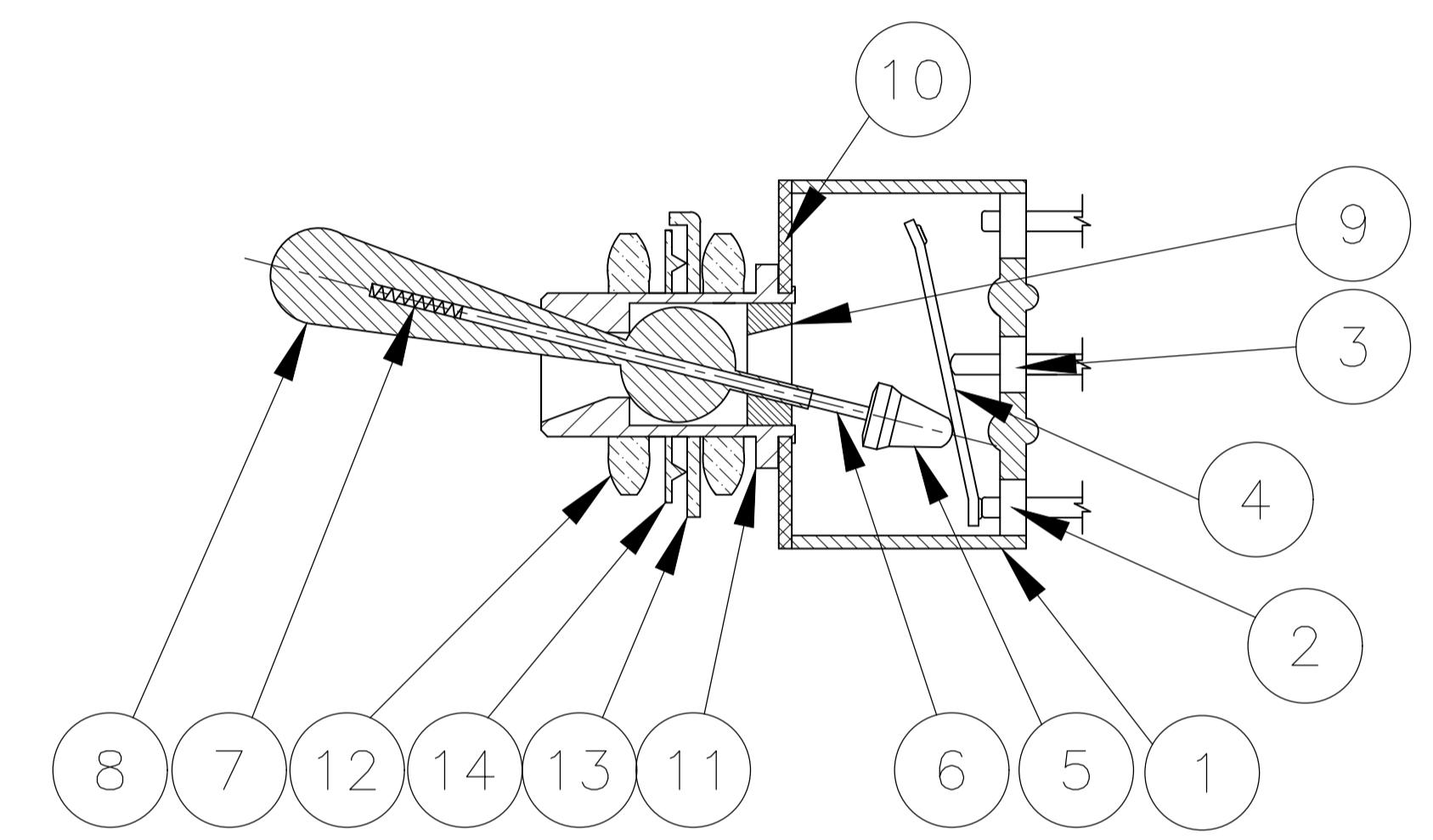

NOT TO SCALE

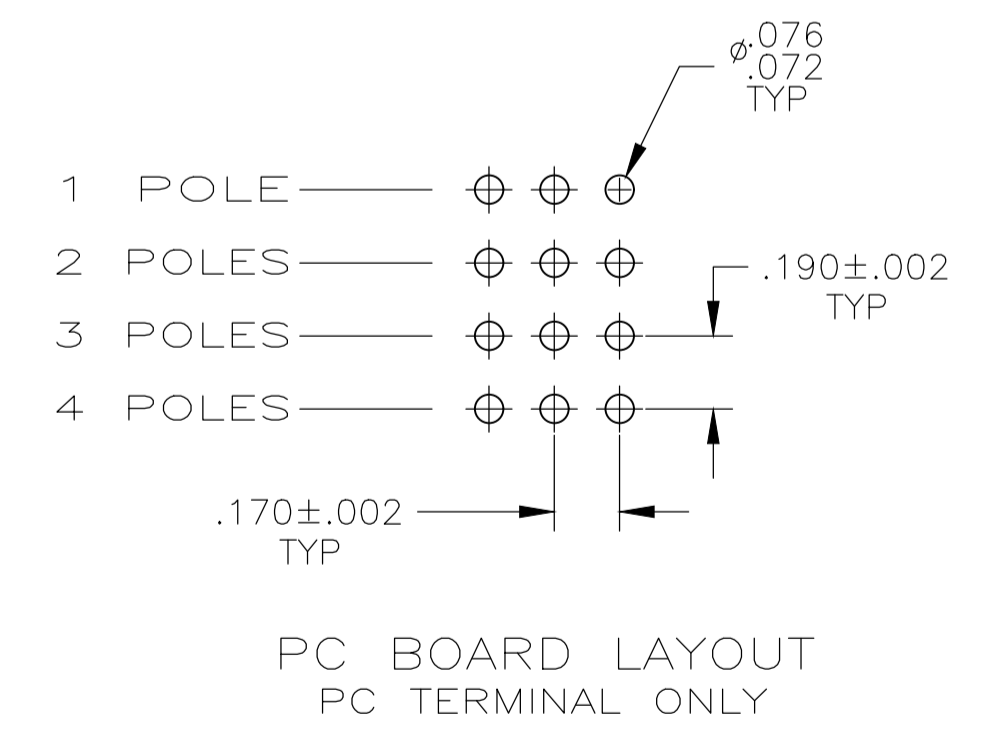
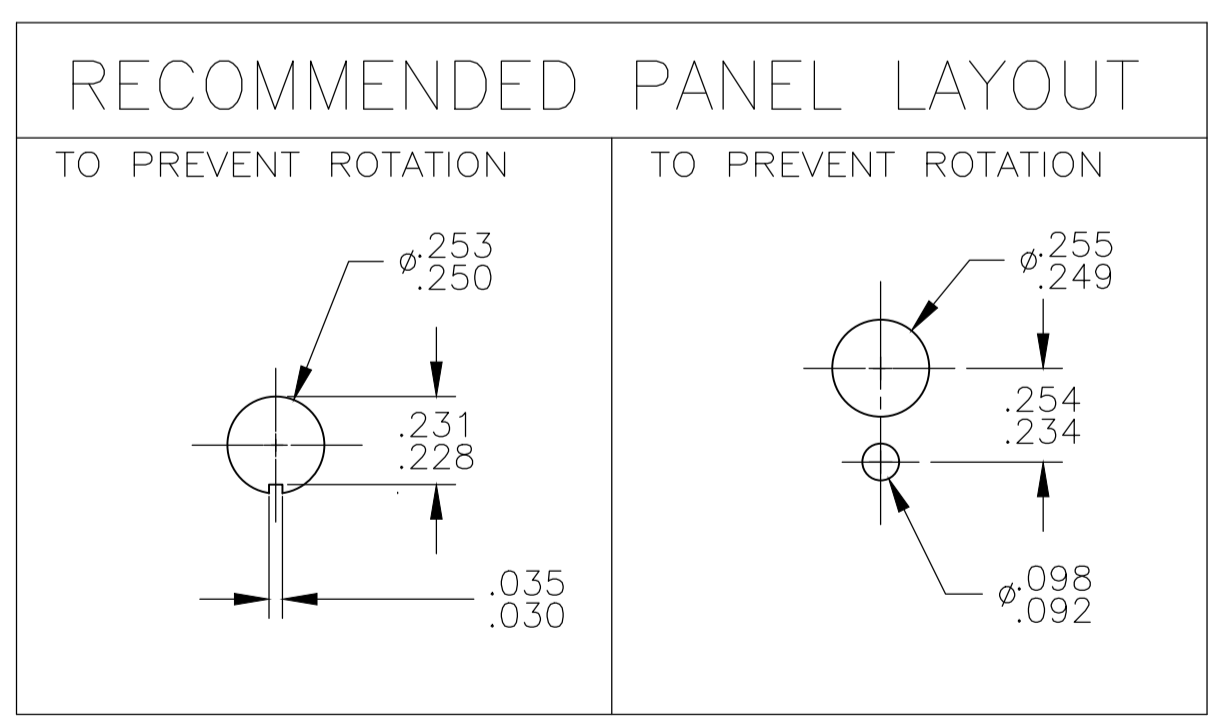

PART NUMBER	ALCO MODEL	POLES	THROWS	FUNCTION	TERMINAL	TERMINAL	TERMINAL	COMMENTS
5-1437559-4	MTM406NPC	4	2	ON ON	PC	2-3, 5-6, 8-9, 11-12	---	2-1, 5-4, 8-7, 11-10
5-1437559-3	MTM306DPC	3	2	ON ON	PC	2-3, 5-6, 8-9	---	2-1, 5-4, 8-7
5-1437559-2	MTM206SPC	2	2	(ON) OFF (ON)	PC	2-3, 5-6	OFF	2-1, 5-4
5-1437559-1	MTM206PPC	2	2	ON OFF ON	PC	2-3, 5-6	OFF	2-1, 5-4
5-1437559-0	MTM206PAPC	1	3	ON ON ON	PC	5-6	5-3	5-1 note 5
4-1437559-9	MTM206NPC	2	2	ON ON	PC	2-3, 5-6	---	2-1, 5-4
4-1437559-8	MTM106FPC	1	2	ON (ON)	PC	2-3	---	2-1
4-1437559-7	MTM106EPC	1	2	ON OFF ON	PC	2-3	Off	2-1
4-1437559-6	MTM106DPC	1	2	ON ON	PC	2-3	---	2-1

- PER SPEC 202-37
NOTES:
- TERMINAL NUMBERS ARE FOR REFERENCE ONLY AND DO NOT APPEAR ON THE SWITCHES.
 - EACH SWITCH SUPPLIED WITH THE FOLLOWING MOUNTING HARDWARE:
 - (2) 1/4-40 UNS-2B HEX NUTS
 - (1) INTERNAL TOOTH LOCKWASHER
 - (1) LOCATING RING

5. CUSTOMER INSTALLED EXTERNAL JUMPER BETWEEN TERMINALS 2 AND 4 REQUIRED FOR 1 POLE 3 THROW FUNCTION.

6. OBSOLETE

7. LASER MARKING USED FOR PARTS.

THIS DRAWING IS A CONTROLLED DOCUMENT.

DIMENSIONS: INCHES
 TOLERANCES UNLESS OTHERWISE SPECIFIED:
 0. PLC ± -
 1. PLC ± -
 2. PLC ± -
 3. PLC ± .005
 4. PLC ± -
 ANGLES ± -

MATERIAL: - FINISH: -
 WEIGHT: -
 CUSTOMER DRAWING

DWG: M. BINNER 29DEC03
 CHK: M. ZITTO 29DEC03
 APP'D: M. ZITTO 29DEC03
 NAME: TOGGLE SWITCH, MTM SERIES VERTICAL MOUNT

SIZE: A1
 CASE CODE: 00779
 DRAWING NO: 4-1437559-9
 RESTRICTED TO: -
 SCALE: 4:1 SHEET: 1 OF 3 REV: E4

REVISIONS				
#	DATE	DESCRIPTION	DATE	APP'D
-	-	SEE SHEET 1	-	-

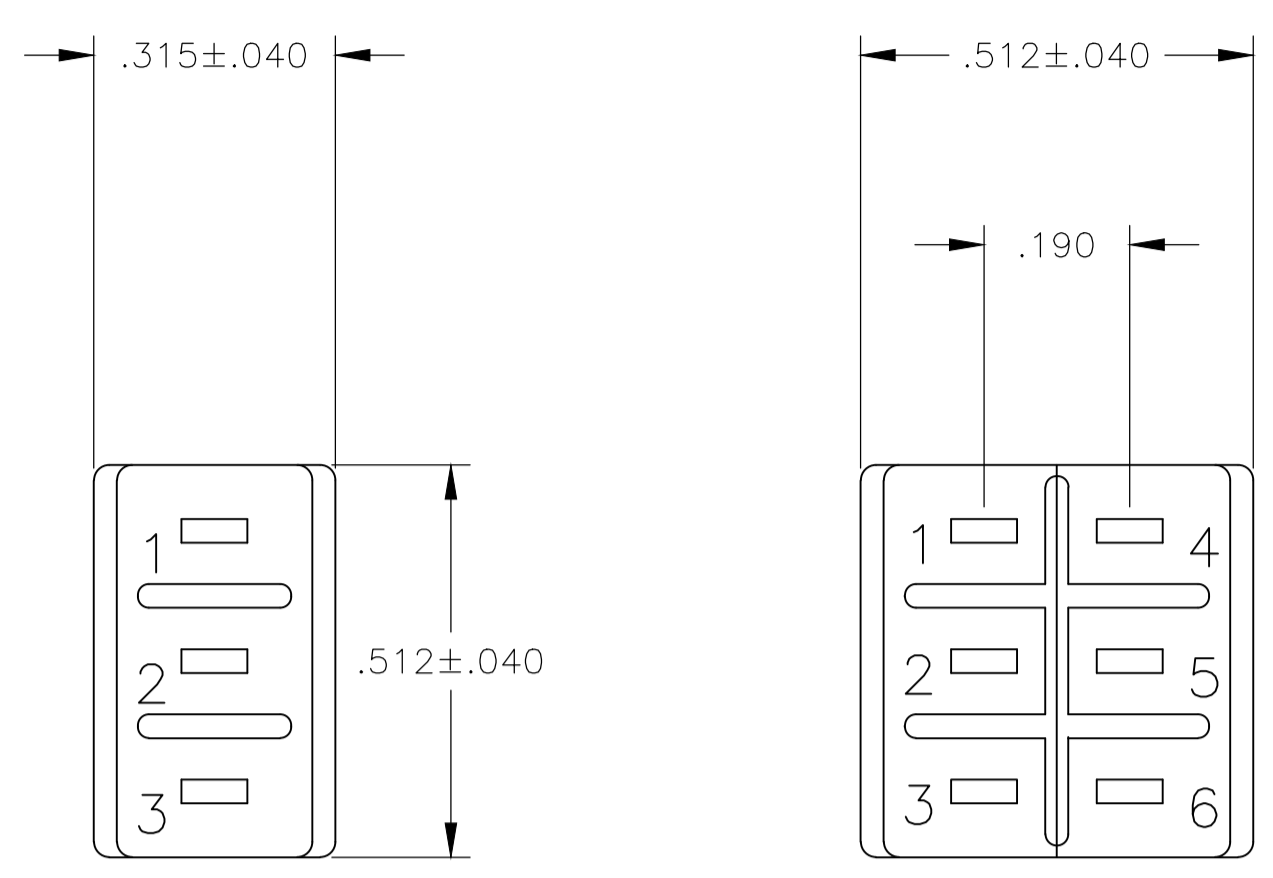
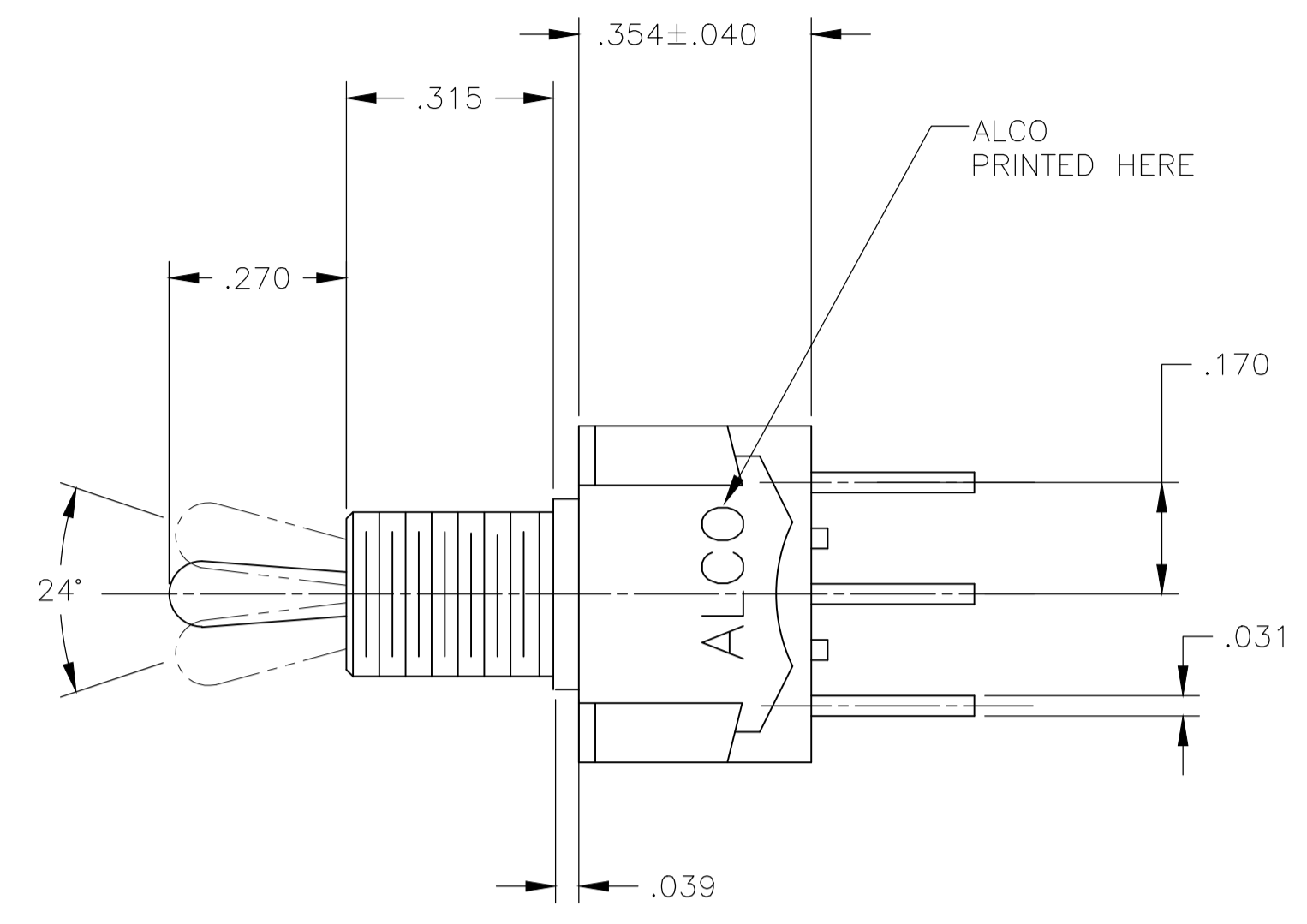

MTM-106 MTM-206

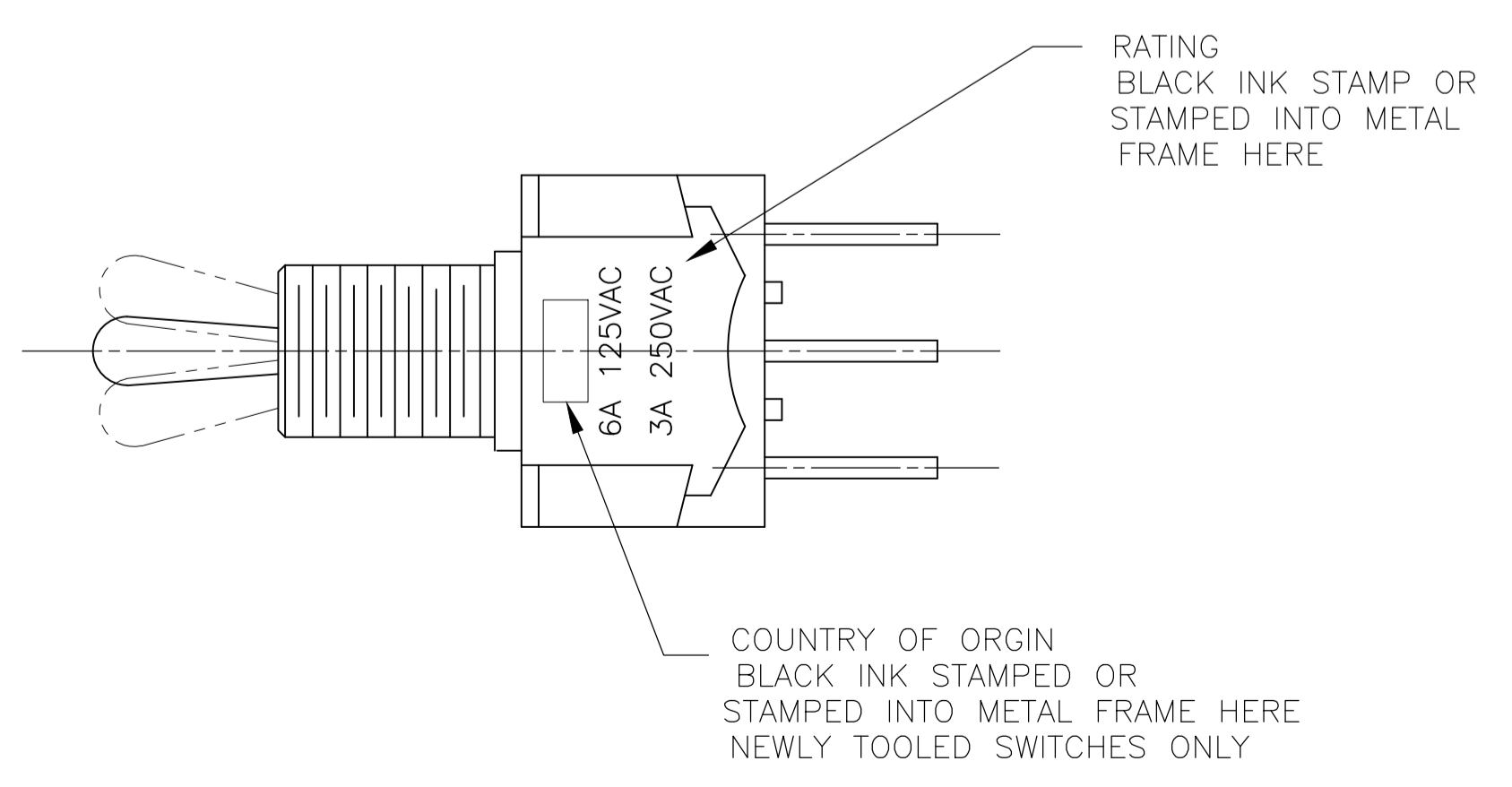
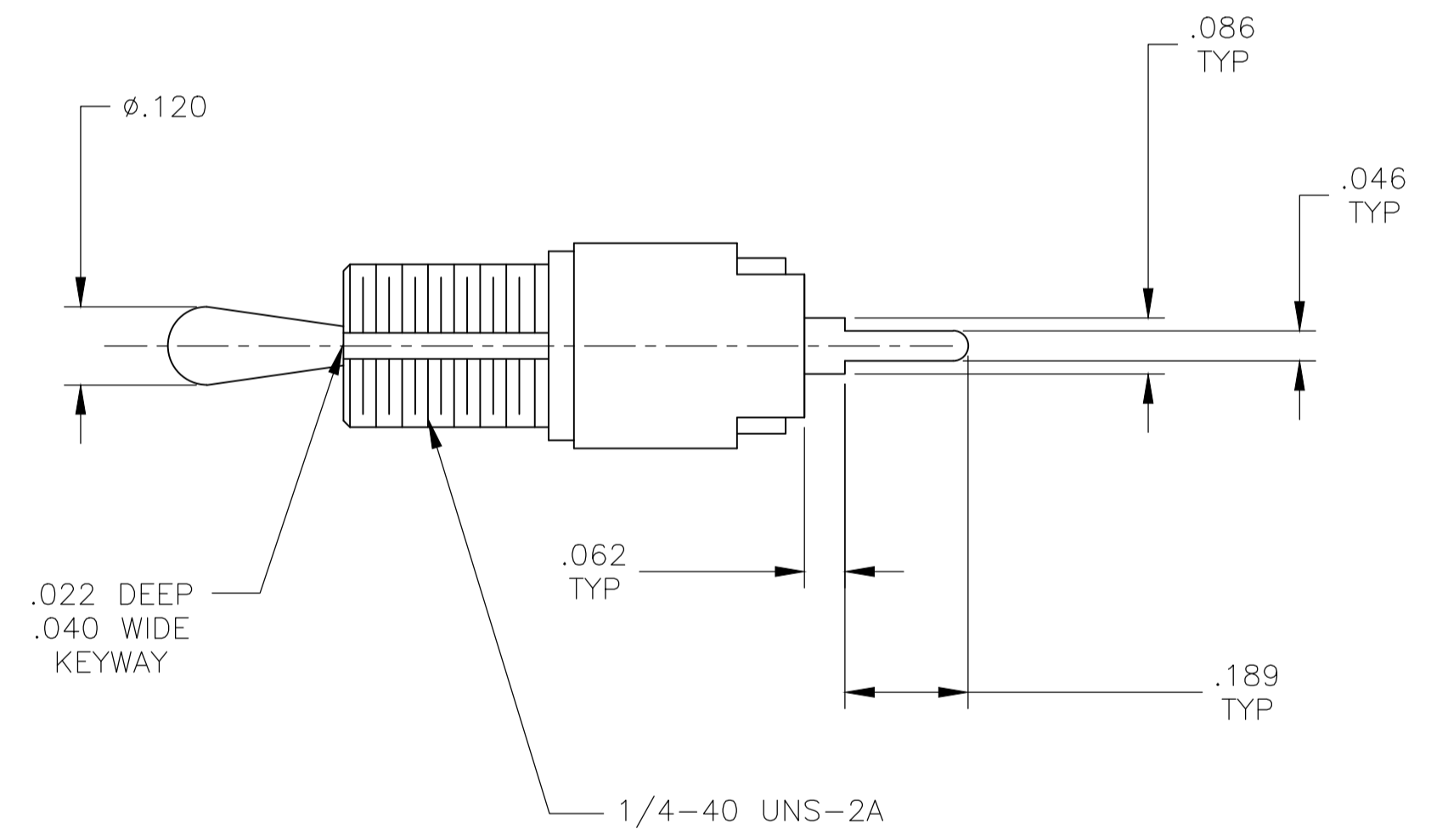
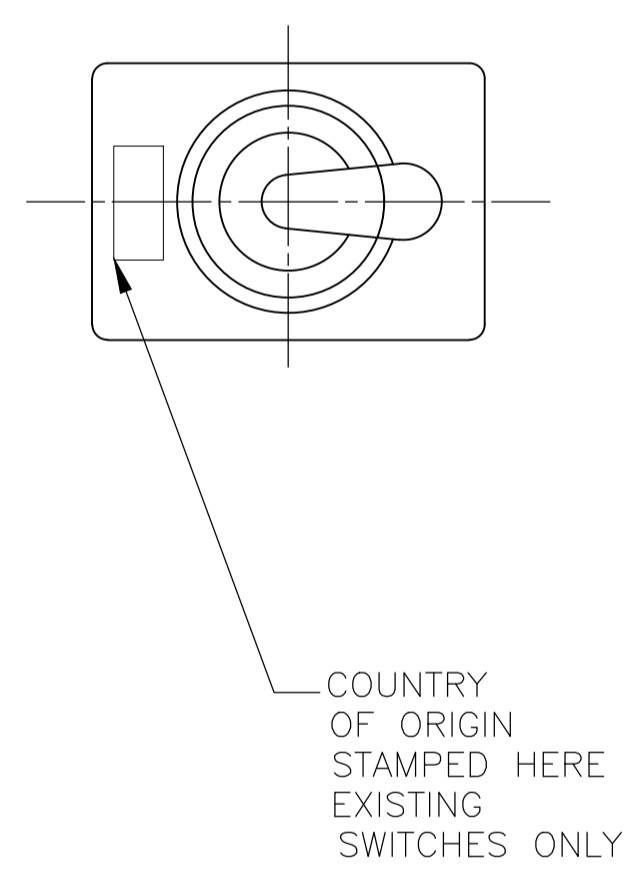

THIS DRAWING IS A CONTROLLED DOCUMENT.		DWN: M. BINNER	29DEC03	TE Connectivity Ltd.
DIMENSIONS: INCHES		CHK: M. ZITTO	29DEC03	
TOLERANCES UNLESS OTHERWISE SPECIFIED:		APP'D: M. ZITTO	29DEC03	NAME: TOGGLE SWITCH, MTM SERIES VERTICAL MOUNT
0 PLC ± -	1 PLC ± -	PRODUCT SPEC		SIZE: CAGE CODE: DRAWING NO:
2 PLC ± -	3 PLC ± .005	APPLICATION SPEC		RESTRICTED TO:
4 PLC ± -	ANGLES ± -	WEIGHT		A1 00779 © 4-1437559-9
MATERIAL: -	FINISH: -	CUSTOMER DRAWING	SCALE: 4:1	SHEET 2 OF 3 REV E4

REVISIONS				
P	LTR	DESCRIPTION	DATE	OWN
-	-	SEE SHEET 1	-	-

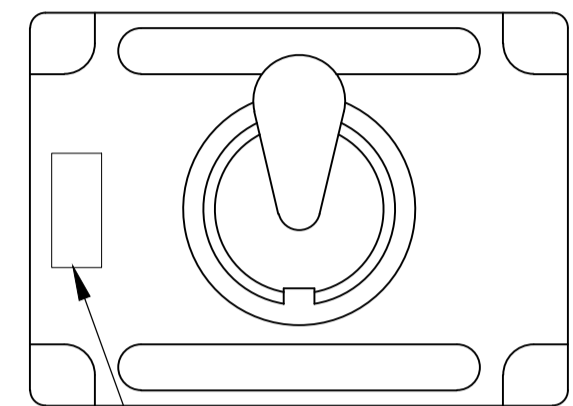

COUNTRY OF ORIGIN STAMPED HERE EXISTING SWITCHES ONLY

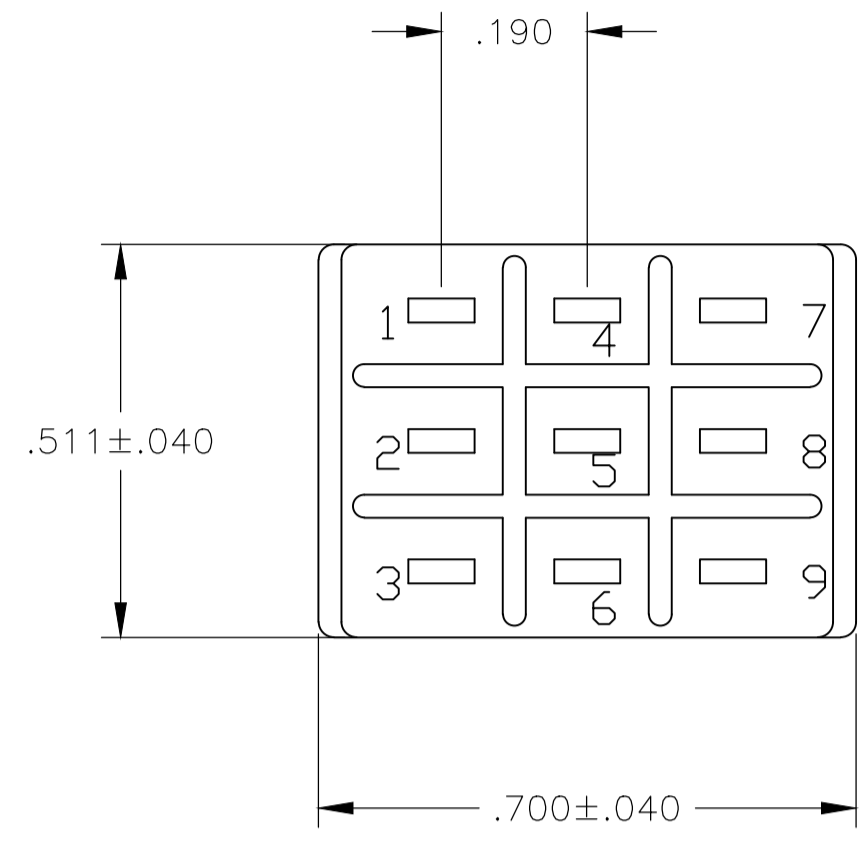
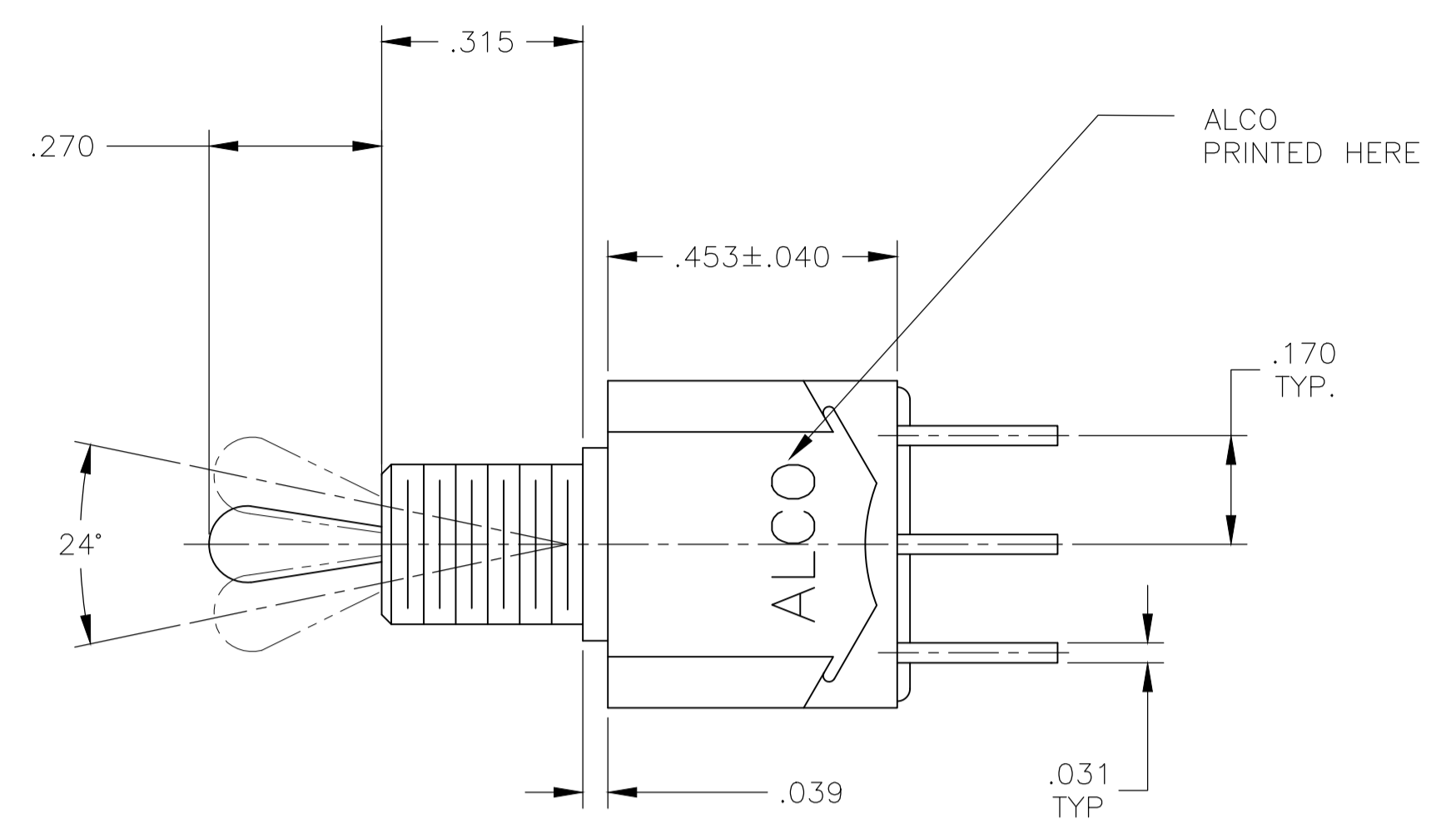

MTM-306

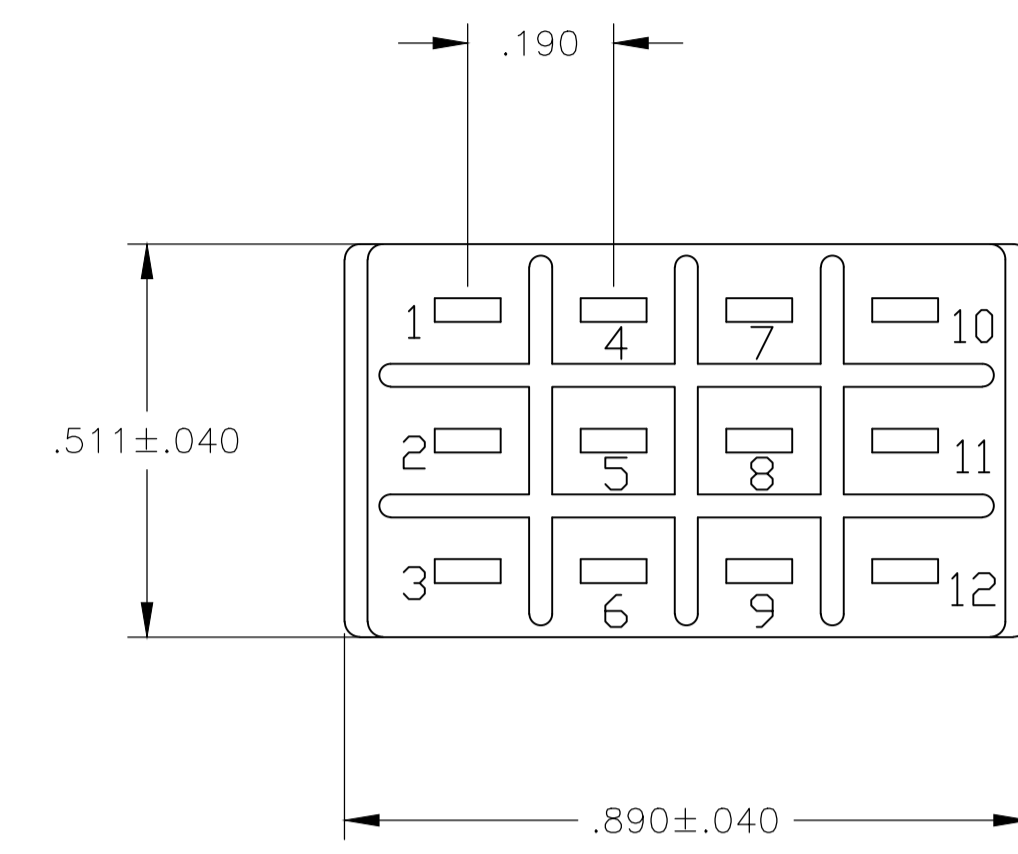

MTM-406

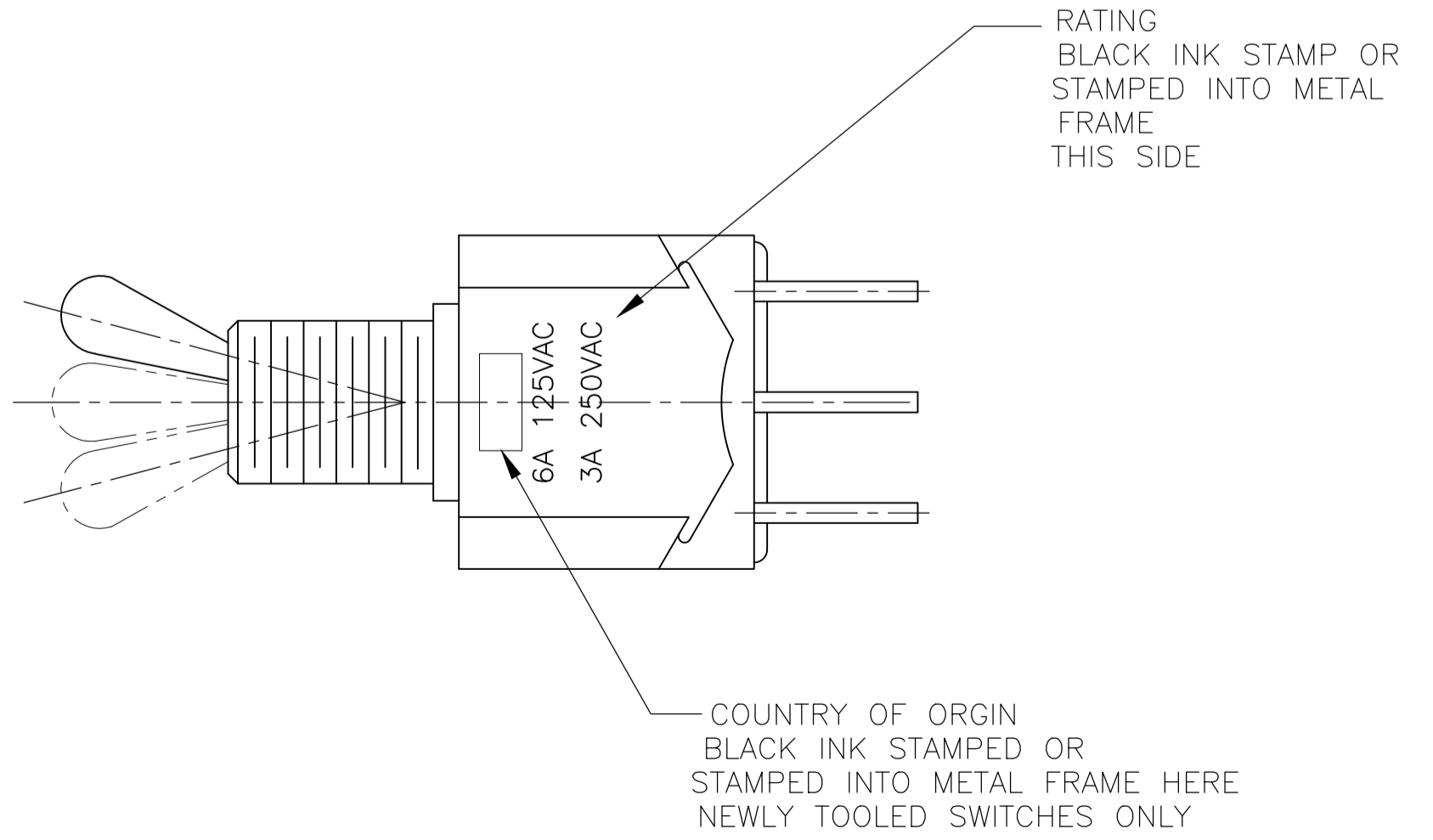
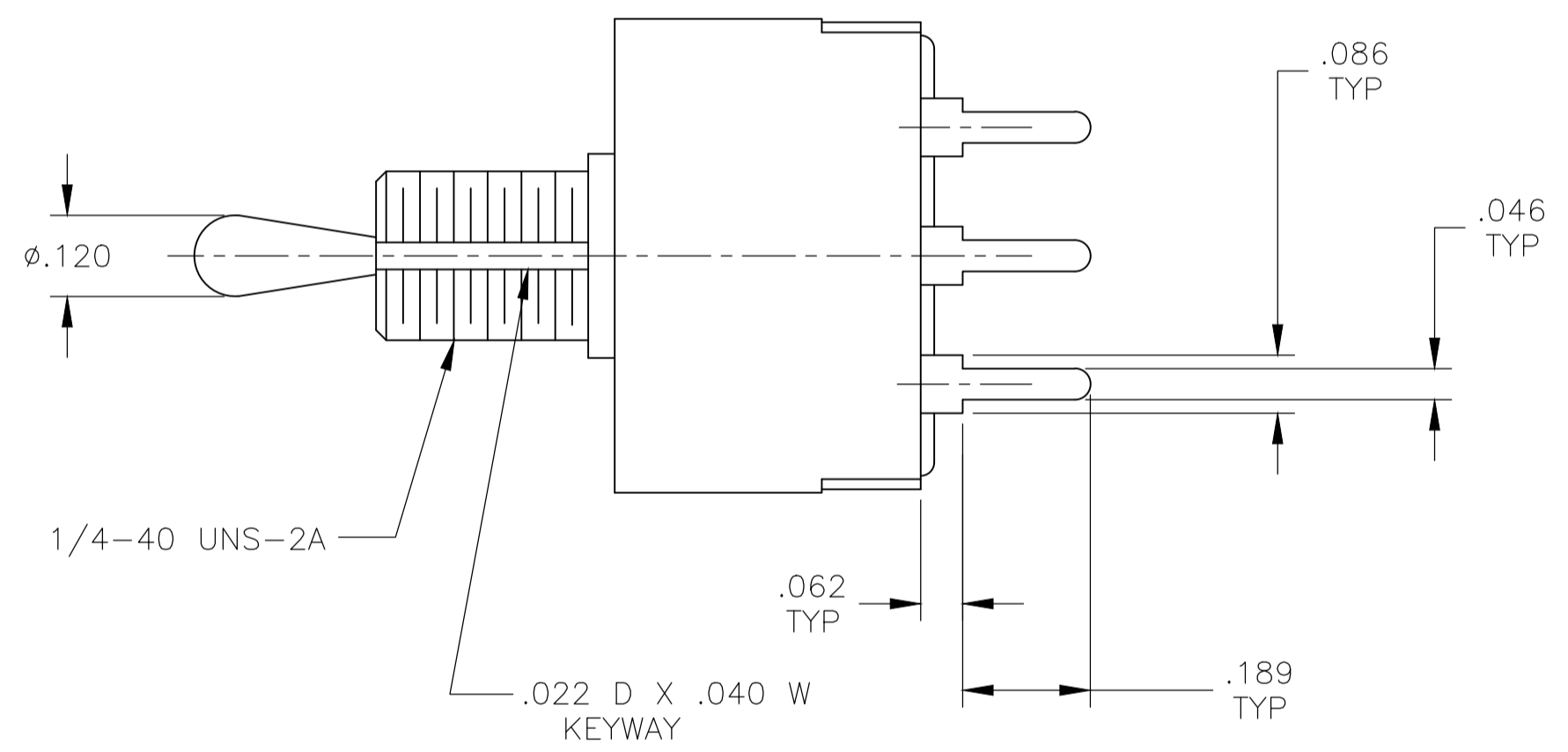

THIS DRAWING IS A CONTROLLED DOCUMENT.		DWN M. BINNER 29DEC03	TE Connectivity Ltd.
DIMENSIONS: INCHES		CHK M. ZITTO 29DEC03	
TOLERANCES UNLESS OTHERWISE SPECIFIED:		NAME M. ZITTO 29DEC03	TOGGLE SWITCH, MTM SERIES VERTICAL MOUNT
0. PLC ± -		PRODUCT SPEC	
1. PLC ± -		APPLICATION SPEC	
2. PLC ± -		SIZE	A1
3. PLC ± .005		WEIGHT	00779
4. PLC ± -		CAGE CODE	4-1437559-9
ANGLES ± -		DRAWING NO	4-1437559-9
MATERIAL -	FINISH -	CUSTOMER DRAWING	SCALE 4:1 SHEET 3 OF 3 REV E4