

6

5

4

3

2

1

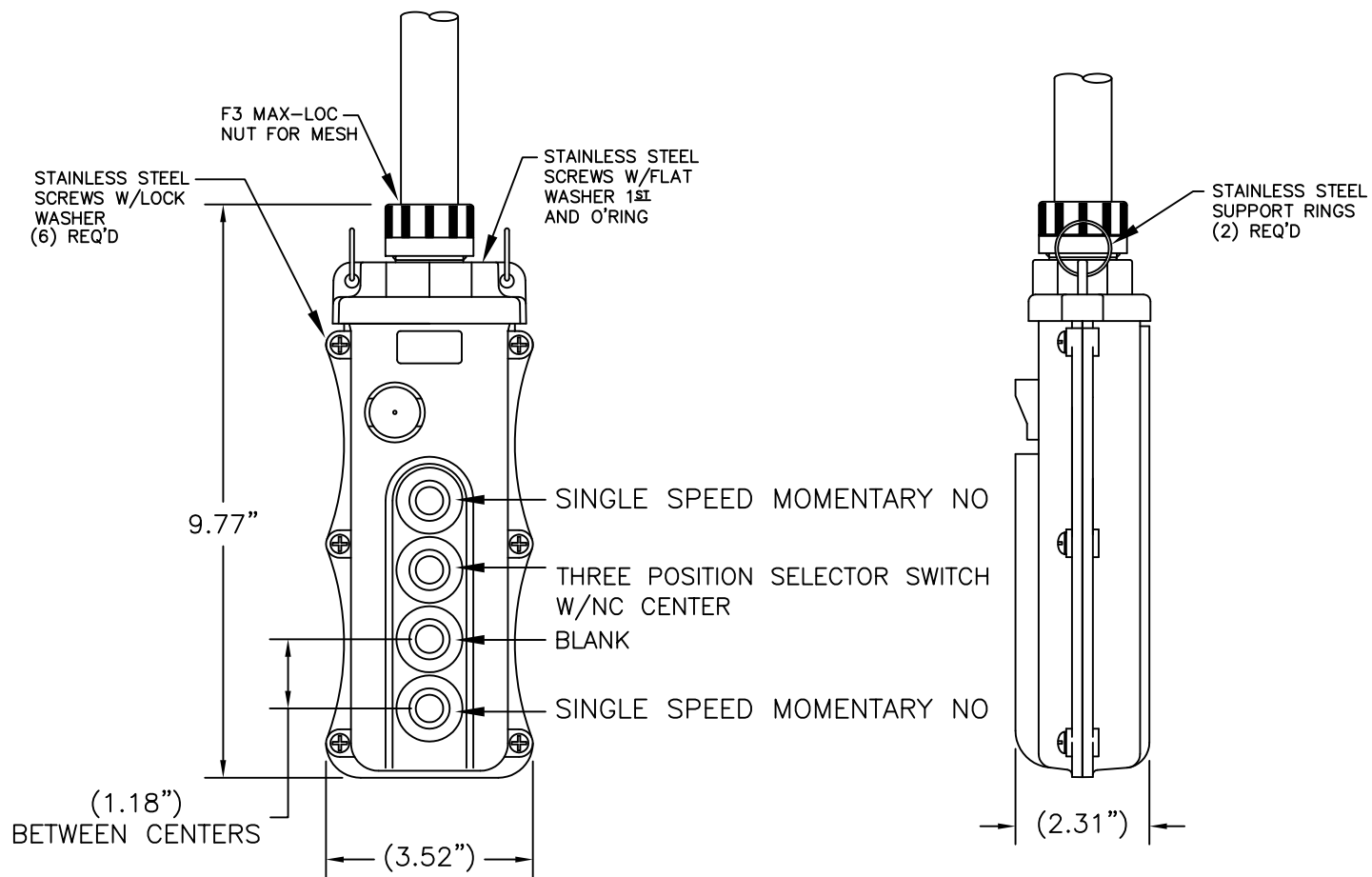

## NOTES:

1. INSTALLATION INSTRUCTIONS, BUTTON ID. LABELS. ARE PACK WITH THE PART.
2. ALL BUTTONS ARE HIGH AMBIENT, CHEMICALLY RESISTANT MATERIAL - COLOR BLACK

|  |                       |   |  |                  |                      |                     |   |                   |                        |  |
|--|-----------------------|---|--|------------------|----------------------|---------------------|---|-------------------|------------------------|--|
| RELEASE DRAWING<br>EC NO: WNA2010-0607<br>DRWN: TVICKERS 2010/03/26<br>CHKD: HK<br>APPR: DTITUS 2010/06/08<br>REV: A | DESCRIPTION<br>DTITUS | QUALITY SYMBOLS<br>$\nabla=0$<br>$\nabla C=0$ | GENERAL TOLERANCES (UNLESS SPECIFIED)                |                  | DIMENSION STYLE INCH |                     | SCALE NTS   | DESIGN UNITS INCH | THIRD ANGLE PROJECTION |  |
|  |                       |   |  | mm               | INCH                 | DRAWN BY DATE       | TITLE   |                   |                        |  |
|  |                       |   | 4 PLACES   | ±---             | ±---                 | TVICKERS 2010/03/26 | 4 POS PENDANT W/(2) SINGLE SPD MOMENTARY NO   |                   |                        |  |
|  |                       |   | 3 PLACES   | ±---             | ±.005                | CHECKED BY DATE     |   |                   |                        |  |
| 2 PLACES   | ±0.13                 | ±.010   | HK 2008/08/08  | APPROVED BY DATE | MOLEX INCORPORATED   |                     |   |                   |                        |  |
| 1 PLACE  | ±0.25                 | ±.020   | DTITUS 2010/06/08                                    | MATERIAL NO.     |                      | DOCUMENT NO.        | SHEET NO.   |                   |                        |  |
| ANGULAR ±.5°   |                       |   | DRAFT WHERE APPLICABLE MUST REMAIN WITHIN DIMENSIONS |                  | 1301260326           |                     | SD-130126-040   |                   | 1 OF 1                 |  |
|  |                       |   |  |                  | SIZE A               |                     | THIS DRAWING CONTAINS INFORMATION THAT IS PROPRIETARY TO MOLEX INCORPORATED AND SHOULD NOT BE USED WITHOUT WRITTEN PERMISSION |                   |                        |  |

6

5

4

3

2

1