

# MAX8895 Evaluation Kit

## Evaluates: MAX8895W/MAX8895X/MAX8895Y

### General Description

The MAX8895 evaluation kit (EV kit) is a fully assembled and tested PCB for evaluating the MAX8895\_ dual-path lithium-ion (Li+) battery chargers. The EV kit is powered from a USB port or dedicated charger with automatic detection of adapter type and USB enumeration capability.

The EV kit features LED indicators for charging ( $\overline{\text{CHG}}$ ), prequalification state ( $\overline{\text{PREQ}}$ ), power-ok ( $\overline{\text{UOK}}$ ), and fault condition ( $\overline{\text{FLT}}$ ). The LEDs can be powered from SYS, BAT+, or BUS through an external LDO. The EV kit also features programmable charging currents (JU1, JU2), NTC thermistor for thermal protection (R11), and logic switches for the MAX8895\_ features (SW1, SW2).

By default, the EV kit is configured for the MAX8895Y, but can also be reconfigured for the MAX8895W/MAX8895X with slight board/hardware modifications. To evaluate the MAX8895W/MAX8895X, request free samples of the MAX8895WEWA+/MAX8895XEWA+ when ordering the EV kit and see the *Evaluating the MAX8895W/MAX8895X* section.

### Features

- ◆ **Micro-B USB Connector**
- ◆ **Dual-Speed Operation (Full Speed: MAX8895Y; Low Speed: MAX8895W/MAX8895X)**
- ◆ **Input Overvoltage Protection to 16V**
- ◆ **Automatic Current Sharing Between Battery Charging and System**
- ◆ **Smart Power Selector™ Operates with Discharged or No Battery**
- ◆ **LED Indicators**
- ◆ **Logic Switches**
- ◆ **NTC Monitoring of Battery Temperature**
- ◆ **Thermal Regulation Prevents Overheating**

### Ordering Information

PART	TYPE
MAX8895EVKIT+	EV Kit

+Denotes lead(Pb)-free and RoHS compliant.

### Component List

DESIGNATION	QTY	DESCRIPTION
C1	1	10 $\mu$ F $\pm$ 10%, 16V X5R ceramic capacitor (0805) TDK C2012X5R1C106KB Taiyo Yuden EMK212BJ106KG-T
C2, C3	2	10 $\mu$ F $\pm$ 10%, 6.3V X5R ceramic capacitors (0603) TDK C1608X5R0J106MB Taiyo Yuden JMK107BJ106MA-T
C4, C5	2	0.1 $\mu$ F $\pm$ 10%, 6.3V X5R ceramic capacitors (0402) TDK C1005X5R1C104KT Taiyo Yuden LMK105BJ104KV Murata GRM155R60J104K
C6–C11	0	Not installed, capacitors (0402)
D1–D4	4	Red LEDs OSRAM LS L296-P2Q2-1-Z
JU1, JU2	2	5-pin headers Digi-Key S1012E-36-ND

DESIGNATION	QTY	DESCRIPTION
JU3	1	4-pin header Digi-Key S1012E-36-ND
JU4–JU8	0	Not installed, 2-pin headers JU4, JU5, JU7 are PCB short; JU6, JU8 are open
P1	1	Micro-B USB receptacle Hirose H11635CT-ND ZX62-AB-5PA(11)
R1–R4	4	270 $\Omega$ $\pm$ 5% resistors (0402), lead free
R5	1	3.74k $\Omega$ $\pm$ 1% resistor (0402), lead free
R6	1	1.87k $\Omega$ $\pm$ 1% resistor (0402), lead free
R7, R13	2	30.1k $\Omega$ $\pm$ 1% resistors (0402), lead free
R8	1	10k $\Omega$ $\pm$ 1% resistor (0402), lead free

Smart Power Selector is a trademark of Maxim Integrated Products, Inc.

**For pricing, delivery, and ordering information, please contact Maxim Direct at 1-888-629-4642, or visit Maxim's website at [www.maximintegrated.com](http://www.maximintegrated.com).**

# MAX8895 Evaluation Kit

## Evaluates: MAX8895W/MAX8895X/MAX8895Y

### Component List (continued)

DESIGNATION	QTY	DESCRIPTION
R9, R10	2	100k $\Omega$ $\pm$ 1% resistors (0402), lead free
R11	1	100k $\Omega$ NTC thermistor ( $\beta$ = 4100) Vishay NTCS0603E3104FXT
R12	1	1M $\Omega$ $\pm$ 5% resistor (0402), lead free
R14	1	15k $\Omega$ $\pm$ 1% resistor (0402), lead free
R15	1	243k $\Omega$ $\pm$ 1% resistor (0402), lead free
R16	1	80.6k $\Omega$ $\pm$ 1% resistor (0402), lead free
R17, R18	2	33.2 $\Omega$ $\pm$ 1% resistors (0402), lead free
SW1	1	2-position surface-mount DIP SPDT switch (12 pins, 3 switches) Grayhill 78J03ST

DESIGNATION	QTY	DESCRIPTION
SW2	1	2-position surface-mount DIP SPDT switch (24 pins, 6 switches) Grayhill 78J06ST
U1	1	Dual-path Li+ charger with USB enumeration (25 WLP) Maxim MAX8895YEWA+T, or Maxim MAX8895WEWA+T, or Maxim MAX8895XEWA+T
Y1	1	12MHz $\pm$ 2500ppm crystal Murata CSTCE1205G15L
—	1	USB A-to-micro B cable, 3ft (1m) Hirose ZX64-B-5S-1000-STDA Digi-Key H11609-ND Molex 68784-0001 Digi-Key WM17145-ND
—	1	PCB: MAX8895EVKIT+

### Component Suppliers

SUPPLIER	PHONE	WEB
Digi-Key Corp.	800-344-4539	www.digikey.com
Grayhill Inc.	708-354-2820	www.grayhill.com
Hirose Electric USA Inc.	805-522-7958	www.hiroseusa.com
Murata Electronics North America, Inc.	770-436-1300	www.murata-northamerica.com
OSRAM GmbH	978-777-1900	www.osram.com
Taiyo Yuden	408-573-4150	www.t-yuden.com
TDK Corp.	847-803-6100	www.component.tdk.com
Vishay	402-563-6866	www.vishay.com

**Note:** Indicate that you are using the MAX8895 when contacting these component suppliers.

# MAX8895 Evaluation Kit

## Evaluates: MAX8895W/MAX8895X/MAX8895Y

### Quick Start

#### Recommended Equipment

- USB A-to-micro B cable (included with the EV kit)
- Three digital multimeters (DMM1, DMM2, DMM3)
- 10A ammeter
- Electronic load
- Single-cell Li+ battery (not fully charged)
- User-supplied PC with a spare USB port

#### Procedure (MAX8895Y Evaluation)

The MAX8895 EV kit is a fully assembled and tested surface-mount board. Follow the steps below and Figure 3 to set up and verify the MAX8895Y and board operation:

- 1) Verify that there are shorts across jumpers JU5 and JU7.
- 2) Verify that jumpers JU6 and JU8 are open.
- 3) Verify that the ISET, IDN, STDBY, RWU, and  $\overline{\text{CEN}}$  switches are set to the left.
- 4) Verify that the CT and KB\_TM switches are set to the right.
- 5) Verify that shunts are installed between the center pin and pin 2 of jumpers JU1 and JU2.
- 6) Verify that a shunt is installed between pins 1-3 for jumper JU3.
- 7) Observe correct Li+ cell polarity. Connect a single-cell Li+ battery and series 10A ammeter. The positive lead of the ammeter must connect to BAT+ and the negative lead to the positive terminal of the Li+ battery.
- 8) Connect a digital multimeter (DMM1) across the Li+ battery. Connect the positive terminal of DMM1 to the positive terminal of the Li+ battery. Connect the negative terminal of DMM1 to the negative terminal of the Li+ battery and note the battery voltage.
- 9) Connect a digital multimeter (DMM2) from INT\_3V3 to BUS\_DGND.
- 10) Connect a digital multimeter (DMM3) from SYS to SYS\_DGND.
- 11) Preset the electronic load for 400mA and turn off. Connect the positive lead of the electronic load to SYS and the negative lead to SYS\_DGND.
- 12) Plug in a USB cable from P1 to the PC with a 500mA USB port.
- 13) Verify that LED D1 is on, indicating that  $\overline{\text{UOK}}$  is low.
- 14) Verify that LED D2 is on, indicating that the charger is on. If  $V_{\text{BAT+}} < 2.5\text{V}$ , the charger starts in pre-charge mode. If  $V_{\text{BAT+}} \geq 2.5\text{V}$ , the charger starts up in fast-charge mode. If in precharge mode, verify that the ammeter reads 80mA. If in fast-charge mode, verify that the ammeter reads 500mA due to the USB current limit.
- 15) Verify that the voltage read by DMM2 is approximately 3.3V.
- 16) Verify that the voltage read by DMM3 is (DMM1 + 140mV) or 3.4V, whichever is greater.
- 17) Turn on the electronic load and verify that the voltage read by DMM3 is (DMM1 + 140mV) or 3.4V, whichever is greater.
- 18) Turn off the electronic load and wait until DMM1 reads 4.2V, indicating a fully charged battery.
- 19) Verify that LED D2 is off and push the  $\overline{\text{CEN}}$  switch to the right. Remove the battery.
- 20) Verify that DMM3 is approximately 4.3V.
- 21) Remove the USB cable from P1.
- 22) Disconnect all test leads from the EV kit.

#### Procedure (MAX8895W/MAX8895X Evaluation)

Follow the steps below and Figure 2 to set up and verify the MAX8895W/MAX8895X and board operation:

- 1) Verify that there are shorts across jumpers JU6 and JU8.
- 2) Verify that jumpers JU5 and JU7 are open.
- 3) Verify that the ISET, IDN, STDBY,  $\overline{\text{ENU\_EN}}$ , RWU, and  $\overline{\text{CEN}}$  switches are set to the left. If using the MAX8895W, verify that switch No. 4 in SW2 is pushed to the right to set IBUS\_DEF.
- 4) Verify that the CT, SUS\_EN, and KB\_TM switches are set to the right.
- 5) Verify that shunts are installed between the center pin and pin 2 of jumpers JU1 and JU2.
- 6) Verify that a shunt is installed between pins 1-3 for jumper JU3.
- 7) Observe correct Li+ cell polarity. Connect a single-cell Li+ battery and series 10A ammeter. The positive lead of the ammeter must connect to BAT+ and the negative lead to the positive terminal of the Li+ battery.

# MAX8895 Evaluation Kit

## Evaluates: MAX8895W/MAX8895X/MAX8895Y

- 8) Connect a digital multimeter (DMM1) across the Li+ battery. Connect the positive terminal of DMM1 to the positive terminal of the Li+ battery. Connect the negative terminal of DMM1 to the negative terminal of the Li+ battery and note the battery voltage.
- 9) Connect a digital multimeter (DMM2) from INT\_3V3 to BUS\_DGND.
- 10) Connect a digital multimeter (DMM3) from SYS to SYS\_DGND.
- 11) Preset the electronic load for 400mA and turn off. Connect the positive lead of the electronic load to SYS and the negative lead to SYS\_DGND.
- 12) Plug in the USB cable from P1 to the PC with a 500mA USB port.
- 13) Verify that LED D1 is on, indicating that  $\overline{UOK}$  is low.
- 14) Verify that LED D2 is on, indicating that the charger is on. If  $V_{BAT+} < 2.5V$ , the charger starts in precharge mode. If  $V_{BAT+} \geq 2.5V$ , the charger starts up in fast-charge mode. If in precharge mode, verify that the ammeter reads 80mA. If in fast-charge mode, verify that the ammeter reads 500mA. When using the MAX8895W, LED D2 indicates CHG\_TYPE.
- 15) Verify that the voltage read by DMM2 is approximately 3.3V.
- 16) Verify that the voltage read by DMM3 is (DMM1 + 140mV) or 3.4V, whichever is greater
- 17) Turn on the electronic load and verify that the voltage read by DMM3 is (DMM1 + 140mV) or 3.4V, whichever is greater.
- 18) Turn off the electronic load and wait until DMM1 reads 4.2V, indicating a fully charged battery.
- 19) Verify that the ammeter reads 0mA and push the CEN switch to the right. Remove the battery.
- 20) Verify that DMM3 is approximately 4.3V.
- 21) Remove the USB cable from P1.
- 22) Disconnect all test leads from the EV kit.

**Table 1. Jumper Settings (JU1, JU2, JU3)**

JUMPER	EV KIT DEFAULT SETTINGS	FUNCTION
JU1	Center pin to pin labeled 0.8A	JU1 selects the maximum fast-charge current. Connect the center pin to the corresponding pins labeled 0.1A, 0.3A, 0.8A, or 1.6A to select the maximum fast-charge current.
JU2	Center pin to pin labeled 80mA	JU2 selects the charge termination current threshold. Connect the center pin to the corresponding pins labeled 10mA, 30mA, 80mA, or 160mA to select the termination current.
JU3	1-3	External LDO power-supply selector. Connect pin 1 to pins 2, 3, or 4 to select the input power supply for the external LDO. Pin 2 selects SYS, pin 3 selects BUS, and pin 4 selects BAT+. Note that when a jumper is installed between pins 1-3, do not exceed the 6V voltage rating for C2 and U2.

**Table 2. Switch SW1 Settings**

SWITCH NO.	LEFT	RIGHT
1: ISET	ISET is connected to the center pin of jumper JU1. Use JU1 to select the maximum fast-charge current.	ISET is connected to INT_3V3 and the fast-charge current is set to the maximum 600mA.
2: IDN	IDN is connected to the center pin of jumper JU2. Use JU2 to select the termination current.	IDN is connected to INT_3V3 and the termination current is set to the maximum 60mA.
3: CT	CT is connected to AGND and the default timers are used. The default timers are 24min for prequalification, 144min for fast charge, and 6min for maintenance charge.	CT is connected to the C5 capacitor and fault timers are based on the capacitance of C5.

# MAX8895 Evaluation Kit

## Evaluates: MAX8895W/MAX8895X/MAX8895Y

**Table 3. Switch SW2 Settings**

SWITCH NO.	LEFT	RIGHT
1: STDBY	STDBY is connected to DGND and the IC is in automatic detect mode.	STDBY is connected to INT_3V3 and the IC is in suspend mode, regardless of external conditions.
2: $\overline{\text{ENU\_EN}}$ (MAX8895W/ MAX8895X only)	$\overline{\text{ENU\_EN}}$ is connected to DGND and the IC automatically performs enumeration. <b>Note:</b> The MAX8895Y always performs enumeration automatically.	$\overline{\text{ENU\_EN}}$ is connected to INT_3V3 and the input current is limited to 100mA without performing enumeration.
3: SUS_EN (MAX8895W/ MAX8895X only)	SUS_EN is connected to DGND and the IC disables the automatic suspend-mode detection.	SUS_EN is connected to INT_3V3 and the automatic detection of suspend mode is enabled. <b>Note:</b> The MAX8895Y always starts in automatic suspend mode.
4: RWU (MAX8895X/ MAX8895Y only)	RWU is connected to DGND and remote wake-up is supported.	RWU is connected to INT_3V3 and remote wake-up is not supported.
4: IBUS_DEF (MAX8895W only)	IBUS_DEF is connected to DGND and the input limit unit is set to 100mA.	IBUS_DEF is connected to INT_3V3 and the input limit is set to 500mA.
5: $\overline{\text{CEN}}$	$\overline{\text{CEN}}$ is connected to DGND and charging is enabled when a valid source is present on BUS.	$\overline{\text{CEN}}$ is connected to INT_3V3 and charging is disabled.
6: KB_TM	KB_TM is connected to AGND for normal operation.	KB_TM is connected to INT_3V3 and is only used during USB certification.

### **Detailed Description of Hardware**

The MAX8895 EV kit evaluates the MAX8895\_ integrated single-cell Li+ chargers with USB enumeration capability. The EV kit negotiates charging current from the USB host or hub, without processor intervention. The MAX8895\_ also automatically detects for a dedicated charger or USB charger and sets the input current limit accordingly. The maximum battery charge current can be set up to 1.6A through jumper JU1. The USB input power not used by the system charges the battery.

#### **USB Interface**

An integrated USB peripheral controller provides automatic enumeration for full-speed (MAX8895Y) and low-speed (MAX8895W/MAX8895X) modes. The USB controller is in charge of:

- Executing adapter-detection sequence: Detects what type of adapter is externally connected to the USB receptacle (P1) and sets the input current limit accordingly.
- Whether the USB receptacle (P1) is attached to a USB charger (host or hub) or to a USB 2.0 (host or hub). It enumerates as an HID device and negotiates the maximum charging current level (from BUS).

The MAX8895W/MAX8895X operate in low-speed mode using an internal 6MHz oscillator and does not require an external crystal to be USB compliant. The MAX8895Y operates in full-speed mode and requires an external 12MHz crystal (Y1, Figure 4).

According to the USB 2.0 specification, a low-speed device is not allowed to use a standard USB type-B connector, which is why the MAX8895Y is also able to operate in full-speed mode. This makes it possible to use a custom or captive cable for low-speed mode using the MAX8895W/MAX8895X and still be USB compliant. While operating in full-speed mode, using the MAX8895Y allows use of a standard USB type-B connector.

#### **Adapter Detection**

When an adapter is present on the USB receptacle (P1), the IC examines the external device to identify the type of adapter connected.

The possible adapter types are:

- Dedicated charger
- USB charger (host or hub)
- USB 2.0 (host or hub) low power
- USB 2.0 (host or hub) high power

# MAX8895 Evaluation Kit

## Evaluates: MAX8895W/MAX8895X/MAX8895Y

**Table 4. Adapter Types**

ADAPTER TYPE	OUTPUT VOLTAGE	OUTPUT CURRENT
Dedicated charger	4.75V to 5.25V at $I_{LOAD} < 500\text{mA}$ 2V to 5.25V for $I_{LOAD} \geq 500\text{mA}$	500mA to 1.8A
USB charger	4.75V to 5.25V at $I_{LOAD} < 500\text{mA}$ 0 to 5.25V for $I_{LOAD} \geq 500\text{mA}$	500mA to 900mA (low speed, full speed, and high speed), 500mA to 1.5A (low speed and full speed)
USB 2.0 low power	4.25V to 5.25V	100mA (max)
USB 2.0 high power	4.75V to 5.25V	500mA (max)

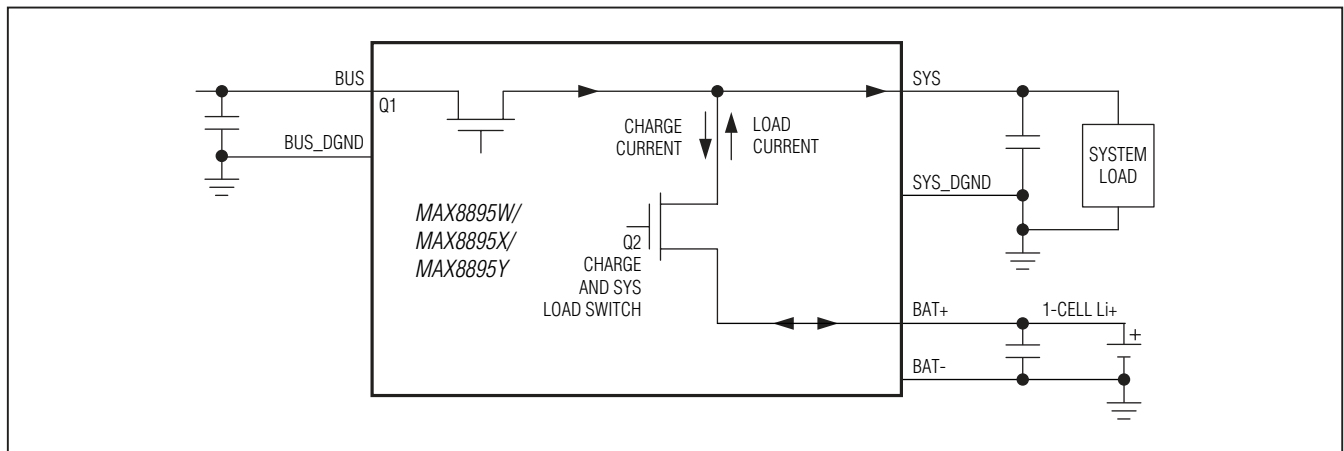

Figure 1. Smart Power Selector

Each of these different devices has different current capability, as shown in Table 4.

When an adapter is connected, the IC performs a series of tests to identify the type of device connected. Refer to the flow charts in the MAX8895W/MAX8895X/MAX8895Y IC data sheet for more details.

### Smart Power Selector (SPS)

The Smart Power Selector seamlessly distributes power between the external adapter input (BUS), the battery (BAT+), and the system load (SYS). Basic functions of the Smart Power Selector include:

- 1) With both an external adapter and battery connected:
  - a. When the system load requirements are less than the input current limit, the battery is charged with residual power from the input.
  - b. When the system load requirements exceed the input current limit, the battery supplies supplemental current to the load.

- 2) When the battery is connected and there is no external power input, the system is powered from the battery.
- 3) When an external power input is connected and there is no battery, the system is powered from BUS.

If the junction temperature starts to get too hot ( $+110^{\circ}\text{C}$ , typ), the charging rate is reduced. If this is not sufficient to cool down the MAX8895\_, then the input current limit is reduced.

### Regulation Threshold

The MAX8895X/MAX8895Y always regulate SYS to 140mV (typ) above BAT+ with a minimum voltage of 3.4V, regardless of what device is connected. The 3.4V minimum voltage regulation reduces the ripple on SYS during peak load conditions where the input current limit is tripped.



# MAX8895 Evaluation Kit

## Evaluates: MAX8895W/MAX8895X/MAX8895Y

### LED Indicators

#### $\overline{UOK}$ Output

$\overline{UOK}$  is an open-drain output that pulls low when the BUS input has valid power.

The  $\overline{UOK}$  monitor has several different thresholds depending on the type of adapter detected. The different thresholds are shown in Table 5.

#### $\overline{FLT}$ Output and Charge Timer

$\overline{FLT}$  is an active-low, open-drain output that is driven low during a battery fault or failed enumeration. If the IC is in the fault state, the corresponding LED (D4) is turned on. The fault state occurs when either the prequalification or fast-charge timer expires. The prequalification and fast-charge fault timers are set by C5:

$$t_{\text{PREQUAL}} = 24\text{min} \times \frac{C5}{0.068\mu\text{F}}$$

$$t_{\text{FCHG}} = 144\text{min} \times \frac{C5}{0.068\mu\text{F}}$$

#### $\overline{PREQ}$ Output (MAX8895X/MAX8895Y Only)

$\overline{PREQ}$  is an active-low, open-drain output that is driven low when the charger is in the prequalification state. If the IC is in the prequalification state, the corresponding LED (D3) is turned on.

#### $\overline{CHG}$ Output (MAX8895X/MAX8895Y Only)

$\overline{CHG}$  is an active-low, open-drain output that is driven low during charging. If the charger is in precharge, fast-charge, or top-off, the corresponding LED (D2) is turned on. When charge current falls below the charge termination threshold, the charger is in voltage mode and D2 is turned off.

**Table 5.  $\overline{UOK}$  Monitor Thresholds**

ADAPTER	UVLO	OVLO
Initial BUS detection	4.0V (typ) rising	6.9V
For USB 2.0 low power	3.9V (typ) falling	
For USB 2.0 high power	4.1V (typ) falling	
For dedicated charger to USB charger	$V_{\text{SYS}} + 50\text{mV}$ (typ) falling	

### Thermistor Input (THM)

The THM input connects to an external negative temperature coefficient (NTC) thermistor to monitor battery or system temperature. Charging is suspended when the thermistor temperature is out of range. The charge timers are suspended and hold their state, but no fault is indicated. When the thermistor comes back into range, charging resumes and the charge timer continues from where it was previously. Connect THM to AGND to disable the thermistor monitoring function. For more details, refer to the MAX8895W/MAX8895X/MAX8895Y IC data sheet.

### Thermal Shutdown

Thermal shutdown limits total power dissipation in the MAX8895X/MAX8895Y. When the junction temperature exceeds +160°C (typ), the device turns off, allowing the IC to cool. The IC turns on and begins soft-start after the junction temperature cools by +20°C (typ). This results in a pulsed charge current during continuous thermal-overload conditions.

### External Crystal/Ceramic Resonator (MAX8895Y)

XIN and XOUT are used to interface to an external 12MHz crystal (Y1). The Y1 crystal contains internal load capacitors; therefore, C6 and C7 are not used. If another crystal is selected and requires load capacitors, refer to the MAX8895W/MAX8895X/MAX8895Y IC data sheet.

### External Clock (MAX8895Y)

The MAX8895Y accepts an external clock input at XIN. Remove the preinstalled crystal (Y1, Figure 4) before driving an external clock signal into XIN. The external clock can either be a digital level square wave or sinusoidal, which can be directly coupled to XIN without the need for additional components. If the peaks of the reference clock are above  $V_{\text{INT\_3V3}}$  or below ground, the clock signal must be driven through a DC-blocking capacitor (~33pF) connected to XIN.

The external clock source can be enabled using the  $\overline{UOK}$  or INT\_3V3 signals depending on whether the clock source is active-low or active-high enabled.

If the INT\_3V3 rail is used, ensure that no significant load is taken from this output since this affects the performance of the MAX8895Y. Because the INT\_3V3 LDO's

# MAX8895 Evaluation Kit

## Evaluates: MAX8895W/MAX8895X/MAX8895Y

input is sourced from VBUS, significant loading could also cause violation of the USB specifications.

### **Evaluating the MAX8895W**

To evaluate the MAX8895W version, request a sample of the MAX8895WEWA+ when ordering the EV kit. To modify the EV kit for evaluation of the MAX8895W, follow the steps below:

- 1) Remove U1 and replace with the MAX8895WEWA+.
- 2) Cut the PCB traces between the two half circles on jumpers JU5 and JU7.
- 3) Solder the two half circles together on jumpers JU6 and JU8.

Note that bumps C1 and D1 are  $\overline{\text{ENU\_EN}}$  (automatic enumeration enable) and  $\overline{\text{SUS\_EN}}$  (automatic suspend-mode detection enable). The MAX8895W operates in USB low speed and does not require an external crystal.

- 4) Bump B2 is  $\overline{\text{CHG\_TYPE}}$ . When using the MAX8895W, the EV kit  $\overline{\text{CHG}}$  label and LED D2 are indications of  $\overline{\text{CHG\_TYPE}}$ . When LED D2 is on, the input current into the IC from a USB 2.0 host is 100mA. When LED D2 is off, the input current can be greater than or equal to 500mA.
- 5) Bump C2 is  $\overline{\text{DET\_DONE}}$ . When using the MAX8895W, the  $\overline{\text{PREQ}}$  label and LED D3 are indications of  $\overline{\text{DET\_DONE}}$ . When LED D3 is on, this is an indication

that adapter detection is complete. When LED D3 is off, this is an indication that the IC is in suspend mode.

- 6) Bump D2 is  $\overline{\text{IBUS\_DEF}}$ . When using the MAX8895W, the RWU toggle switch (No. 4, Table 3) in SW2 is used to control the logic state of  $\overline{\text{IBUS\_DEF}}$ . When switch No. 4 is pushed to the left, the input current limit is set to 100mA. When switch No. 4 is pushed to the right, the input current limit is set to 500mA,

For more details, refer to the MAX8895W/MAX8895X/MAX8895Y IC data sheet.

### **Evaluating the MAX8895X**

To evaluate the MAX8895X version, request a sample of the MAX8895XEWA+ when ordering the EV kit. To modify the EV kit for evaluation of the MAX8895X, follow the steps below:

- 1) Remove U1 and replace with the MAX8895XEWA+.
- 2) Cut the PCB traces between the two half circles on jumpers JU5 and JU7.
- 3) Solder the two half circles together on jumpers JU6 and JU8.

Note that bumps C1 and D1 are  $\overline{\text{ENU\_EN}}$  (automatic enumeration enable) and  $\overline{\text{SUS\_EN}}$  (automatic suspend-mode detection enable). The MAX8895X operates in USB low speed and does not require an external crystal.



# MAX8895 Evaluation Kit

Evaluates: **MAX8895W/MAX8895X/MAX8895Y**

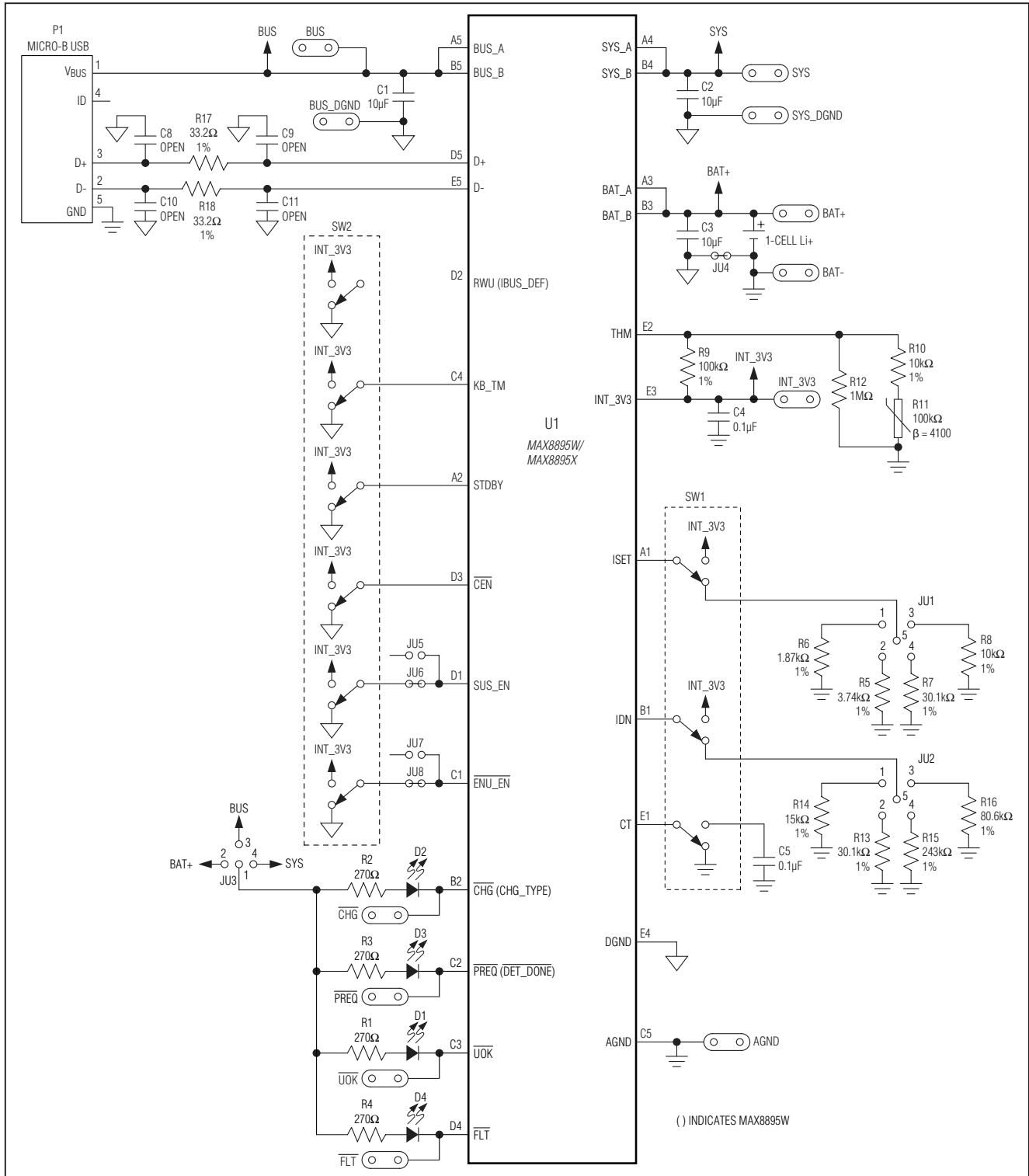

Figure 2. MAX8895 EV Kit Schematic (MAX8895W/MAX8895X Evaluation)

# MAX8895 Evaluation Kit

Evaluates: **MAX8895W/MAX8895X/MAX8895Y**

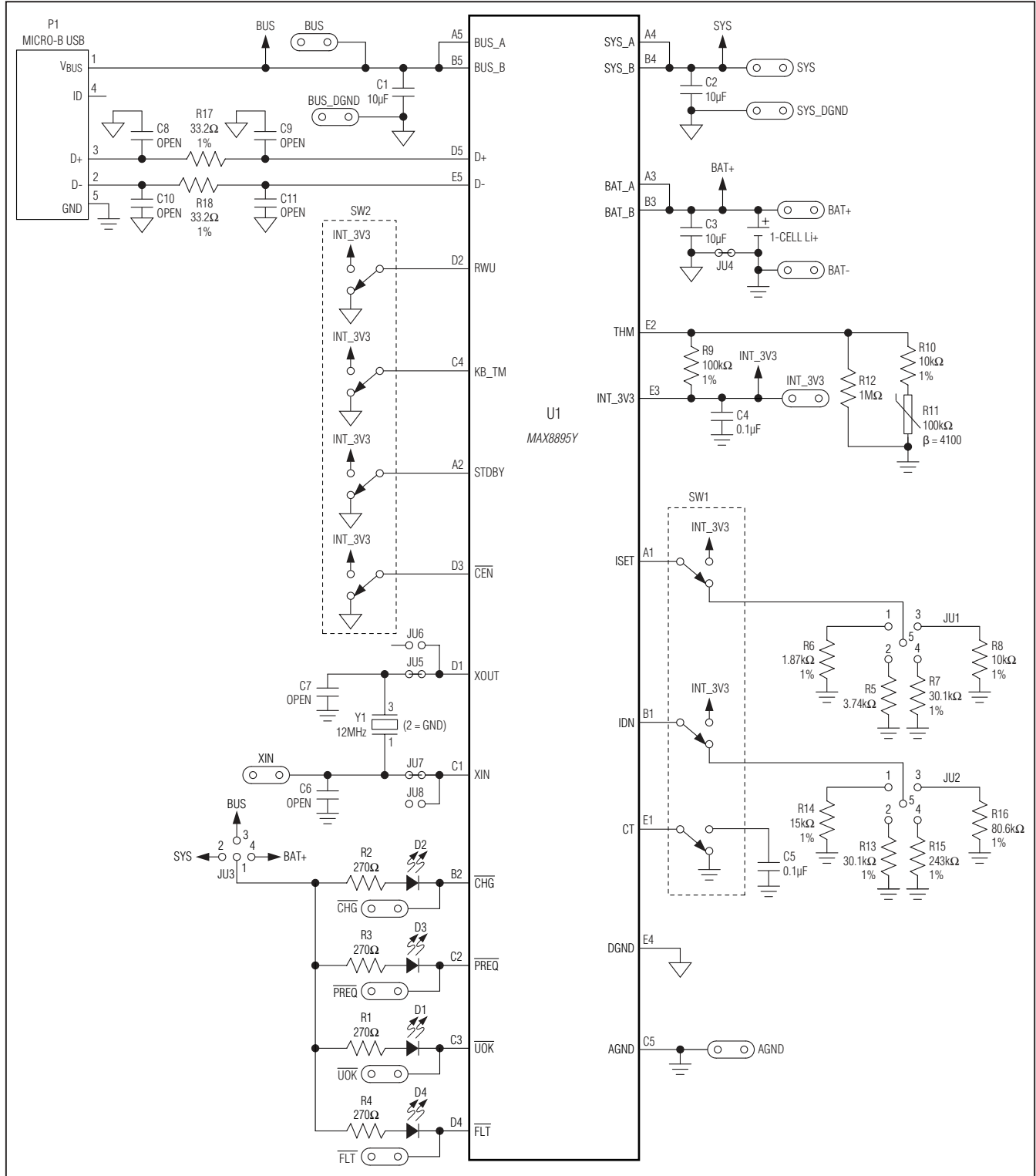

Figure 3. MAX8895 EV Kit Schematic (MAX8895Y Evaluation)

# MAX8895 Evaluation Kit

Evaluates: **MAX8895W/MAX8895X/MAX8895Y**

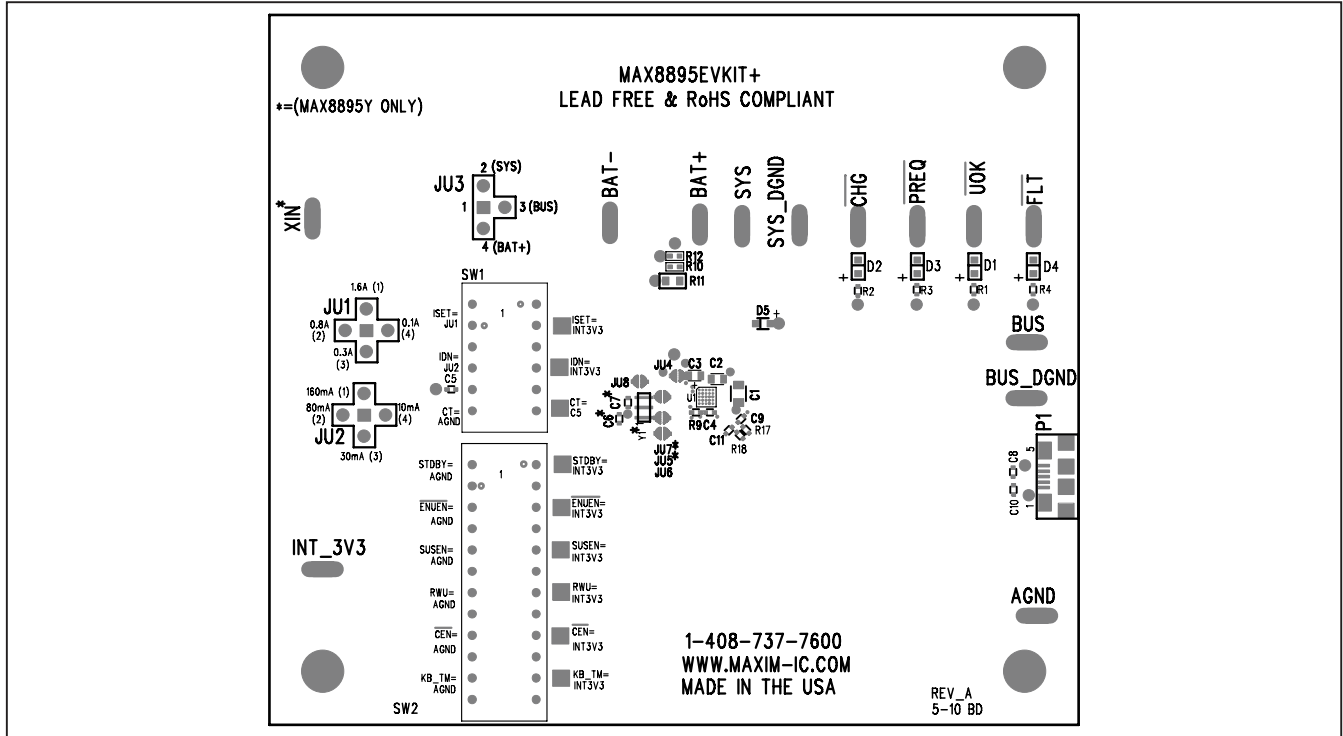

Figure 4. MAX8895 EV Kit Component Placement Guide—Component Side

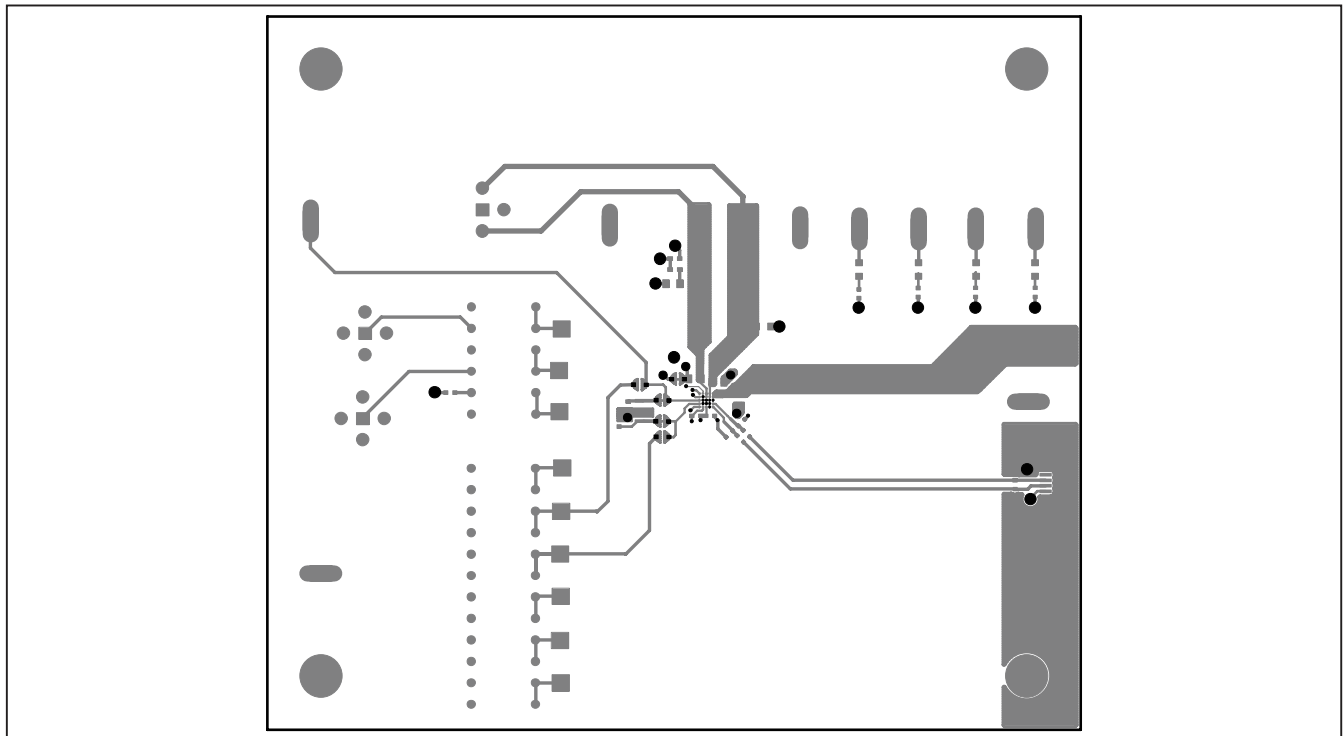

Figure 5. MAX8895 EV Kit PCB Layout—Component Side

# MAX8895 Evaluation Kit

Evaluates: MAX8895W/MAX8895X/MAX8895Y

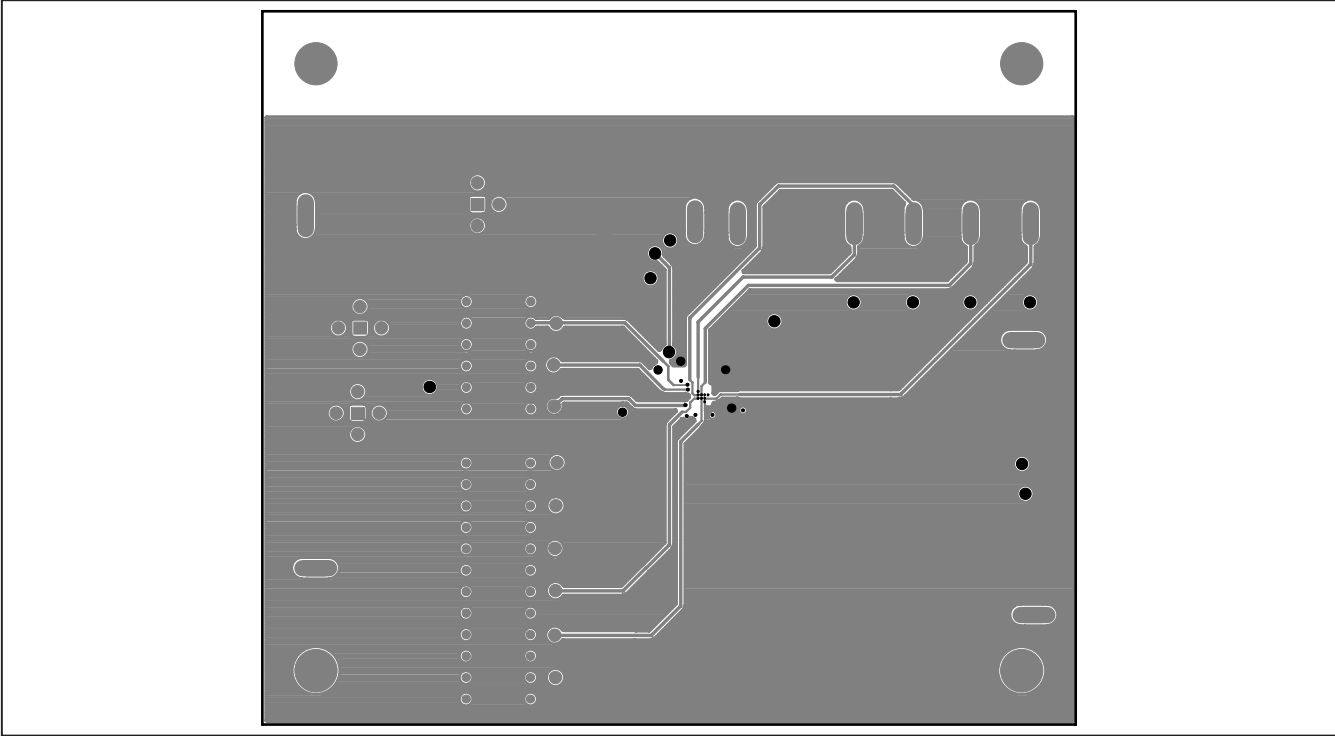

Figure 6. MAX8895 EV Kit PCB Layout—Inner Layer 2

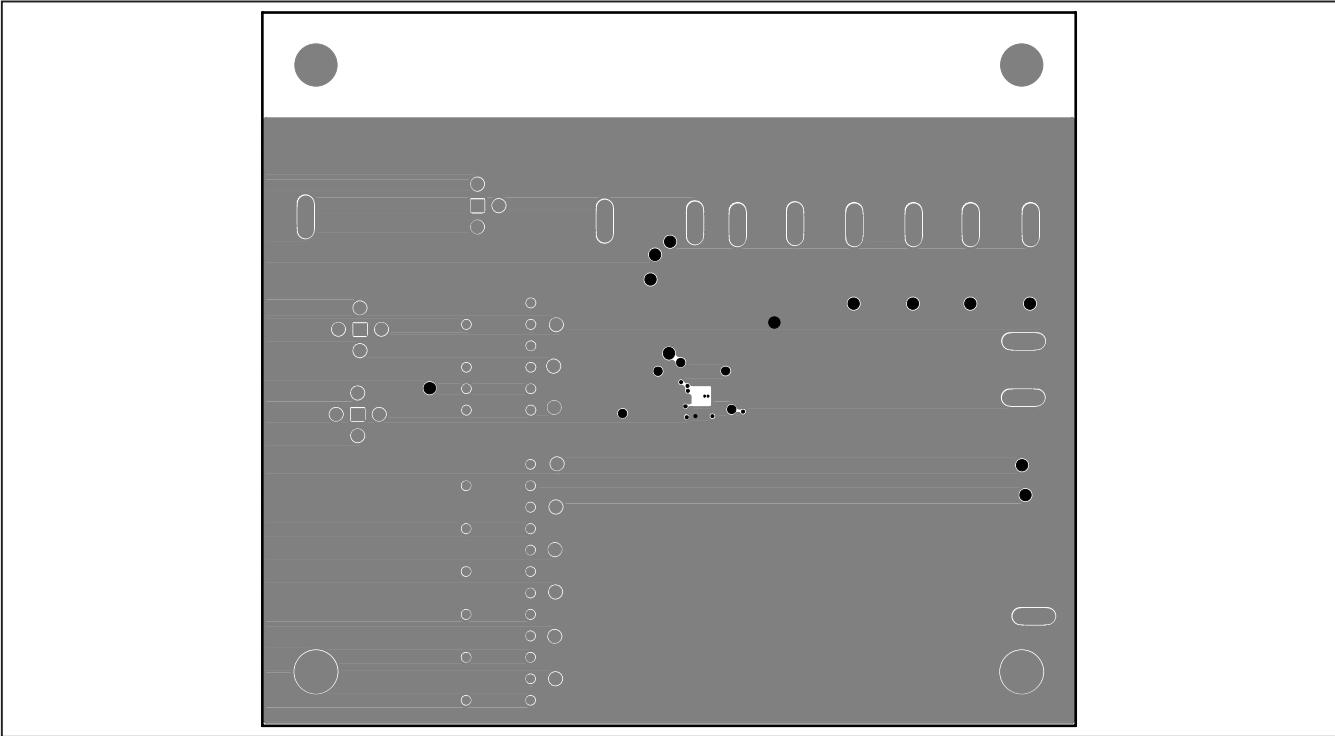

Figure 7. MAX8895 EV Kit PCB Layout—Inner Layer 3

# MAX8895 Evaluation Kit

Evaluates: MAX8895W/MAX8895X/MAX8895Y

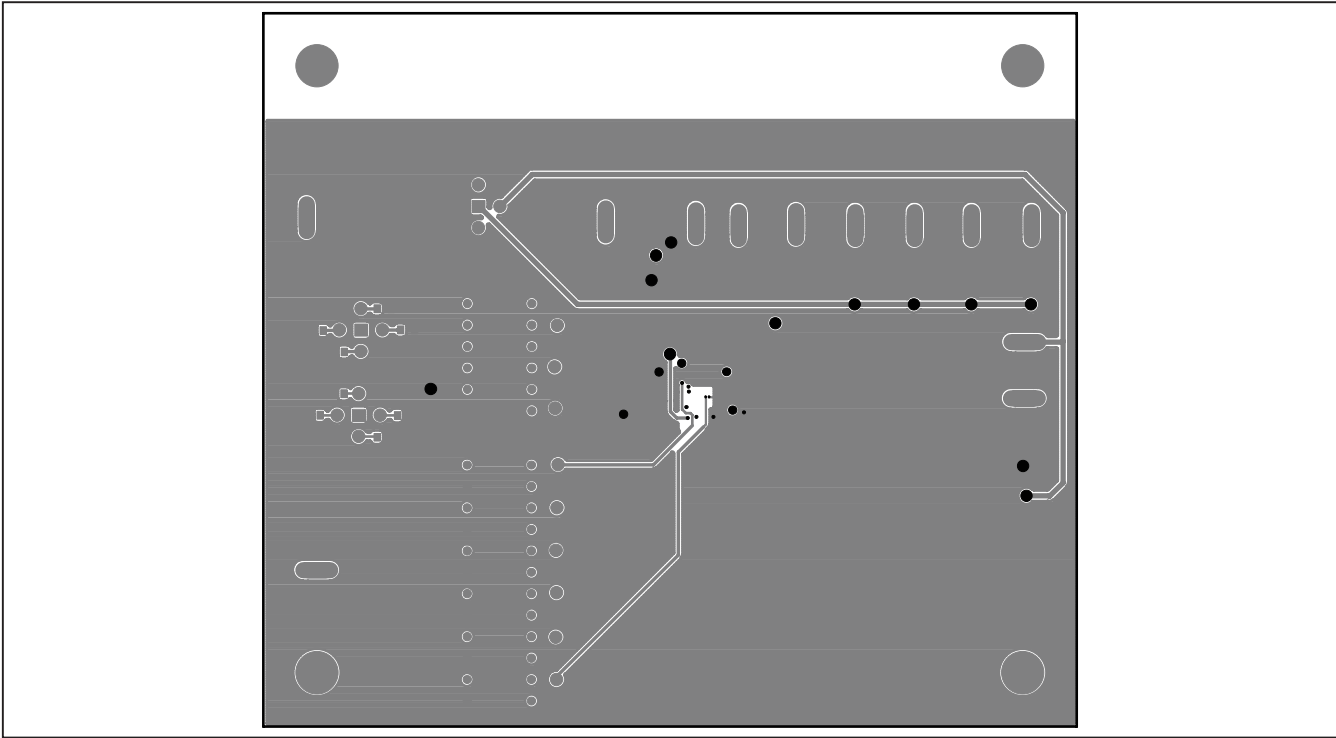

Figure 8. MAX8895 EV Kit PCB Layout—Solder Side

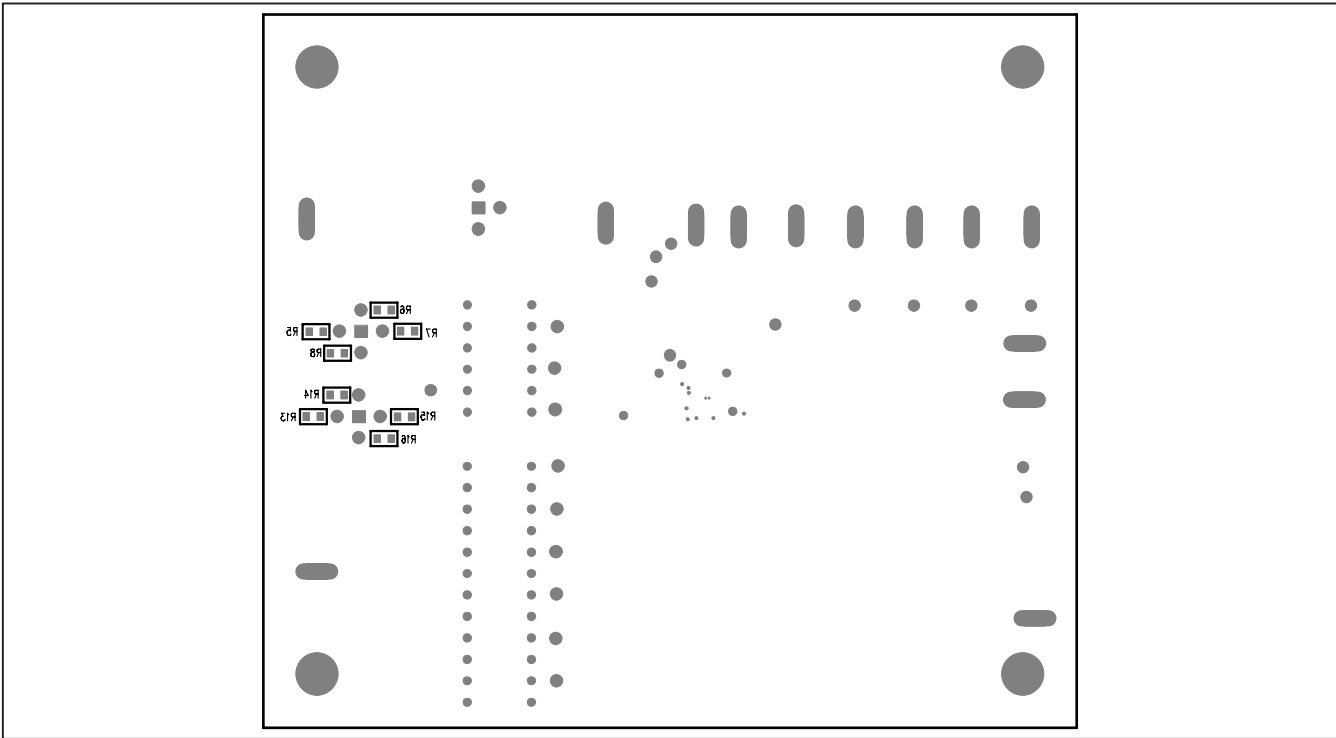

Figure 9. MAX8895 EV Kit Component Placement Guide—Solder Side

# MAX8895 Evaluation Kit

**Evaluates: MAX8895W/MAX8895X/MAX8895Y**

## Revision History

REVISION NUMBER	REVISION DATE	DESCRIPTION	PAGES CHANGED
0	6/10	Initial release	—
1	12/10	Added new part (MAX8895W) and associated details	1–14



*Maxim Integrated cannot assume responsibility for use of any circuitry other than circuitry entirely embodied in a Maxim Integrated product. No circuit patent licenses are implied. Maxim Integrated reserves the right to change the circuitry and specifications without notice at any time. The parametric values (min and max limits) shown in the Electrical Characteristics table are guaranteed. Other parametric values quoted in this data sheet are provided for guidance.*