

LEGEND \diamond = KEY PRODUCT CHARACTERISTICS

REVISION HISTORY

REV	DESCRIPTION	DATE	BY	ECN
0	FIRST ISSUE	10/12/2010	M.H	8984

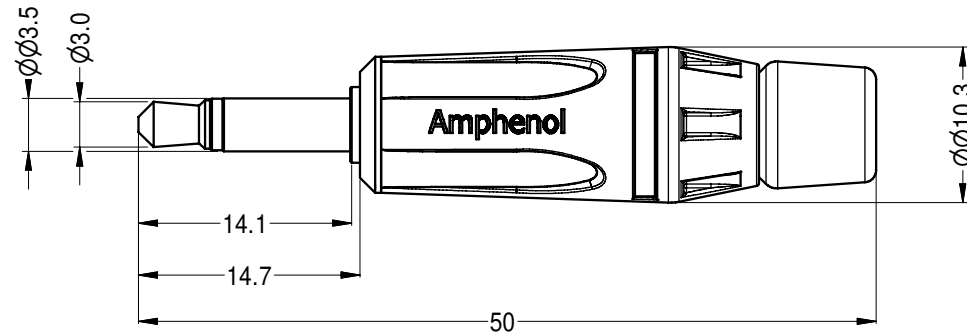
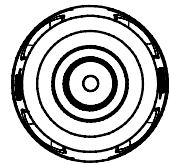

ITEM	PART NUMBER	DESCRIPTION	QTY
3	51270016-521	INSULATE PVC TUBE CLEAR	1
2	51560088-321/121	MONO INSERT ASSEMBLY NICKEL/GOLD	1
1	50440041-300/400	DIECAST SHELL NICKEL/BLACK FINISH	1

Parts List

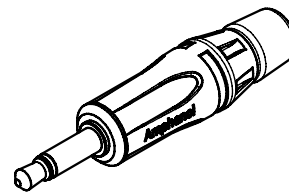

ISO VIEW (1 : 1)

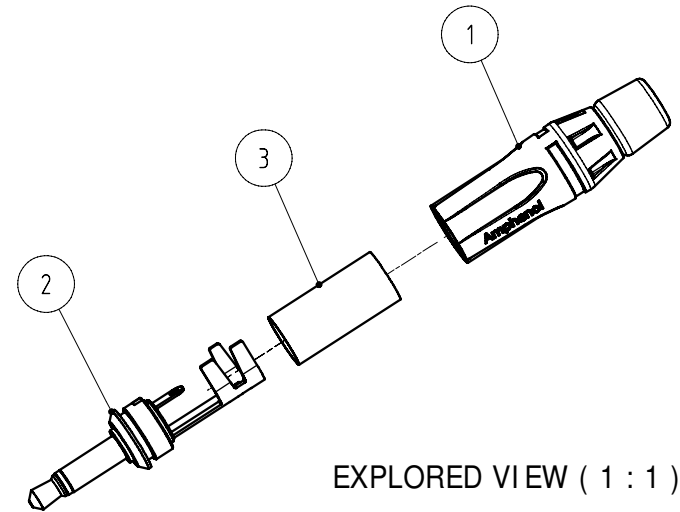

EXPLORED VIEW (1 : 1)

PART NUMBER		
PART NUMBER	SHELL FINISH	CONTACT FINISH
KM2P	NICKEL	NICKEL RING, SLEEVE & TIP
KM2P-AU	NICKEL	GOLD RING, SLEEVE & TIP
KM2PB	BLACK	NICKEL RING, SLEEVE & TIP
KM2PB-AU	BLACK	GOLD RING, SLEEVE & TIP

UNLESS OTHERWISE SPECIFIED TOLERANCE TO BE		THIS DOCUMENT IS THE PROPERTY OF AMPHENOL AUSTRALIA PTY. LTD. NO PART THEREOF MAY BE REPRODUCED AND USED WITHOUT THE PRIOR WRITTEN CONSENT OF THE OWNER			
LINEAR	ANGULAR	MATERIAL:	DRN: T.Z	DATE: 10-12-10	TITLE: 3.5mm MONO PHONE PLUG CUSTOMER DRAWING
X ± 0.5 X.X ± 0.25 X.XX ± 0.1	X' ± 1 X.X' ± 30' X.XX' ± 15'	SEE PARTS LIST & TABLE	CKD: M.H	DATE: 10-12-10	
BREAK ALL SHARP EDGES AND REMOVE ALL BURRS		FINISH: SEE TABLE	APP'D: P.M	DATE: 10-12-10	
DO NOT SCALE		THIRD ANGLE PROJECTION	SCALE: 2:1	SIZE: A4	CAD FILE: 55010723000120
DIMENSIONS IN MILLIMETRES					

Amphenol Amphenol Australia Pty.Ltd,
2 Fiveways Blvd, Keysborough, VIC 3173

PART No:	SEE TABLE
DRAWING NO.	55010723-000-1
SHEET	1/2