

TRAP 8 Channel Remote Control Systems

Simplified Declaration of Conformity (RED)



BG - С настоящото RF Solutions Limited декларира, че този тип радиосъоръжение дефинирани в този документ е в съответствие с Директива 2014/53/EC. Цялостният текст на ЕС декларацията за съответствие може да се намери на следния интернет адрес: www.rfsolutions.co.uk

CS -Tímto RF Solutions Limited prohlašuje, že typ rádiového zařízení definované v tomto dokumentu je v souladu se směrnicí 2014/53/EU. Úplné znění EU prohlášení o shodě je k dispozici na této internetové adrese: www.rfsolutions.co.uk

DA - Hermed erklærer RF Solutions Limited, at radioudstyrstypen defineret i dette dokument er i overensstemmelse med direktiv 2014/53/EU. EU-overensstemmelseserklæringens fulde tekst kan findes på følgende internetadresse: www.rfsolutions.co.uk

DE - Hiermit erkläre RF Solutions Limited, dass der Funkanlagentyp in diesem Dokument definiert der Richtlinie 2014/53/EU entspricht. Der vollständige Text der EU-Konformitätserklärung ist unter der folgenden Internetadresse verfügbar: www.rfsolutions.co.uk

EL - Με την παρούσα ο/η RF Solutions Limited, δηλώνει ότι ο ραδιοεξοπλισμός ορίζεται σε αυτό το έγγραφο πληροί την οδηγία 2014/53/ΕΕ. Το πλήρες κείμενο της δήλωσης συμμόρφωσης ΕΕ διατίθεται στην ακόλουθη ιστοσελίδα στο διαδίκτυο: www.rfsolutions.co.uk

EN - Hereby, RF Solutions Limited declares that the radio equipment type defined within this document is in compliance with Directive 2014/53/EU. The full text of the EU declaration of conformity is available at the following internet address: www.rfsolutions.co.uk

ES - Por la presente, RF Solutions Limited declara que el tipo de equipo radioeléctrico definido dentro de este documento es conforme con la Directiva 2014/53/UE. El texto completo de la declaración UE de conformidad está disponible en la dirección Internet siguiente: www.rfsolutions.co.uk

ET -Käesolevaga deklareerib RF Solutions Limited, et käesolev raadioseadme tüüp määratletud selles dokumendis vastab direktiivi 2014/53/EL nõuetele. ELi vastavusdeklaratsiooni täielik tekst on kättesaadav järgmisel internetiaadressil: www.rfsolutions.co.uk

FI -RF Solutions Limited vakuuttaa, että radiolaitetyypin määrättyä selles dokumendis on direktiivin 2014/53/EU mukainen. EU-vaatimustenmukaisuusvakuutuksen täysimittainen teksti on saatavilla seuraavassa internetosoitteessa: www.rfsolutions.co.uk

FR - Le soussigné, RF Solutions Limited, déclare que l'équipement radioélectrique du type défini dans ce document est conforme à la directive 2014/53/UE. Le texte complet de la déclaration UE de conformité est disponible à l'adresse internet suivante: www.rfsolutions.co.uk

HR - RF Solutions Limited ovime izjavljuju da je radijska oprema tipa definirani u ovom dokumentu u skladu s Direktivom 2014/53/EU. Cjeloviti tekst EU izjave o sukladnosti dostupan je na sljedećoj internetskoj adresi: www.rfsolutions.co.uk

HU - RF Solutions Limited igazolja, hogy a dokumentumban meghatározottak szerinti típusú rádióberendezés megfelel a 2014/53/EU irányelvnek. Az EU-megfelelőségi nyilatkozat teljes szövege elérhető a következő internetes címen: www.rfsolutions.co.uk

IT - Il fabbricante, RF Solutions Limited, dichiara che il tipo di apparecchiatura radio definito all'interno di questo documento è conforme alla direttiva 2014/53/UE. Il testo completo della dichiarazione di conformità UE è disponibile al seguente indirizzo Internet: www.rfsolutions.co.uk

LT - Aš, RF Solutions Limited, patvirtinu, kad radijo įrenginių tipas apibrėžta šiame dokumente atitinka Direktyvą 2014/53/ES. Visas ES atitikties deklaracijos teksto prieinamas šiuo interneto adresu: www.rfsolutions.co.uk

LV - Ar šo RF Solutions Limited deklarē, ka radioiekārtas kas definēts šajā dokumentā atbilst Direktīvai 2014/53/ES. Pilns ES atbilstības deklarācijas teksts ir pieejams šādā interneta vietnē: www.rfsolutions.co.uk

MT - B'dan, RF Solutions Limited, niddikjara li dan it-tip ta' taghmir tar-radju definit f'dan id-dokument huwa konformi mad-Direttiva 2014/53/UE. It-test kollu tad-dikjarazzjoni ta' konformità tal-UE huwa disponibbli f'dan l-indirizz tal-Internet li ġej: www.rfsolutions.co.uk

NL - Hierbij verklaar ik, RF Solutions Limited, dat het type radioapparaatuur gedefinieerd in dit document conform is met Richtlijn 2014/53/EU. De volledige tekst van de EU-conformiteitsverklaring kan worden geraadpleegd op het volgende internetadres: www.rfsolutions.co.uk

PL - RF Solutions Limited niniejszym oświadczam, że typ urządzenia radiowego zdefiniowane w tym dokumencie jest zgodny z dyrektywą 2014/53/UE. Pełny tekst deklaracji zgodności UE jest dostępny pod następującym adresem internetowym: www.rfsolutions.co.uk

PT - O(a) abaixo assinado(a) RF Solutions Limited declara que o presente tipo de equipamento de rádio definido neste documento está em conformidade com a Diretiva 2014/53/UE. O texto integral da declaração de conformidade está disponível no seguinte endereço de Internet: www.rfsolutions.co.uk

RO - Prin prezenta, RF Solutions Limited declară că tipul de echipamente radio definit în acest document este în conformitate cu Directiva 2014/53/UE. Textul integral al declarației UE de conformitate este disponibil la următoarea adresă internet: www.rfsolutions.co.uk

Disclaimer:

Whilst the information in this document is believed to be correct at the time of issue, RF Solutions Ltd does not accept any liability whatsoever for its accuracy, adequacy or completeness. No express or implied warranty or representation is given relating to the information contained in this document. RF Solutions Ltd reserves the right to make changes and improvements to the product(s) described herein without notice. Buyers and other users should determine for themselves the suitability of any such information or products for their own particular requirements or specifications. RF Solutions Ltd shall not be liable for any loss or damage caused as a result of user's own determination of how to deploy or use RF Solutions Ltd's products. Use of RF Solutions Ltd products or components in life support and/or safety applications is not authorised except with express written approval. No licences are created, implicitly or otherwise, under any of RF Solutions Ltd's intellectual property rights. Liability for loss or damage resulting or caused by reliance on the information contained herein or from the use of the product (including liability resulting from negligence or where RF Solutions Ltd was aware of the possibility of such loss or damage arising) is excluded. This will not operate to limit or restrict RF Solutions Ltd's liability for death or personal injury resulting from its negligence.

RF Solutions Ltd. Recycling Notice

Meets the following EC Directives:

DO NOT Discard with normal waste, please recycle.

ROHS Directive 2011/65/EU and amendment 2015/863/EU

Specifies certain limits for hazardous substances.

WEEE Directive 2012/19/EU

Waste electrical & electronic equipment. This product must be disposed of through a licensed WEEE collection point. RF Solutions Ltd., fulfils its WEEE obligations by membership of an approved compliance scheme.

Environment agency number: **WEE/JB0104WV**.



Waste Batteries and Accumulators Directive 2006/66/EC

Where batteries are fitted, before recycling the product, the batteries must be removed and disposed of at a licensed collection point. RF Solutions battery producer number: **BPRN00060**.



TRAP 8 Channel Remote Control Systems



Quick Start Guide

PART NO.

TRAP-8S8

TRAP-8R8

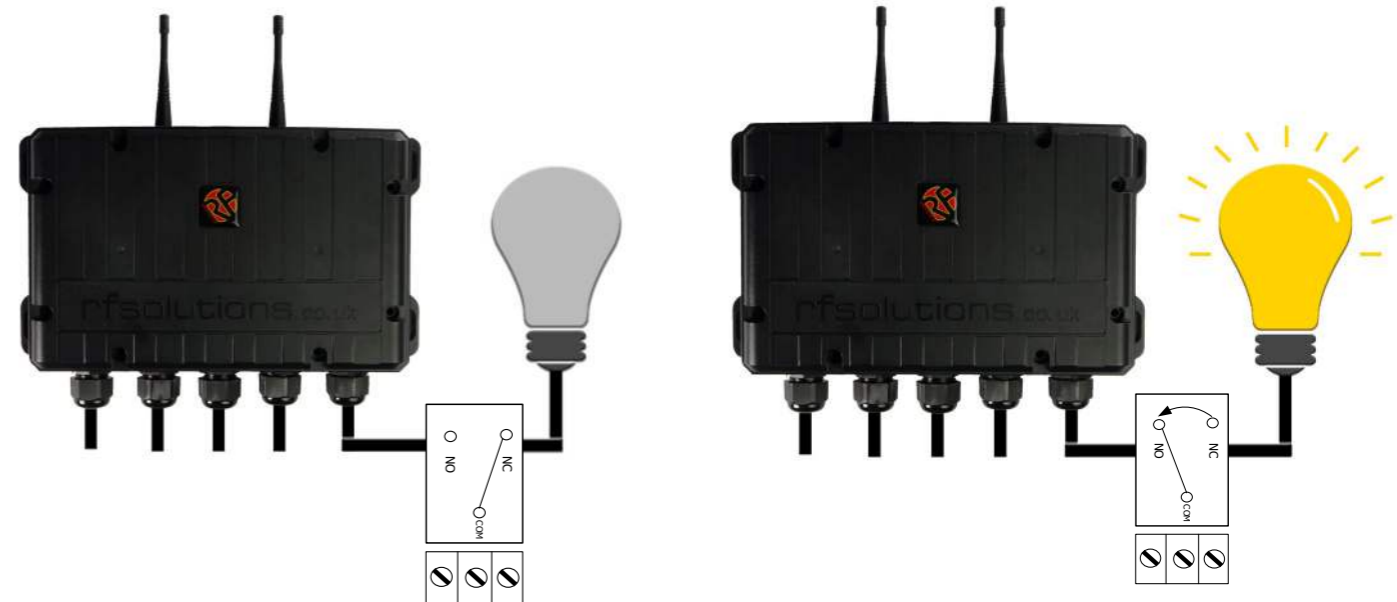

TRAP 8 Channel Remote Control Systems



Safety Information



Carefully read the following safety information before proceeding with installation, operation, or maintenance of RF Solutions product. Failure to follow these warnings could result in death or serious injury.

- This radio system must not be used in areas where there is a risk of explosion.
- Only qualified personnel should be permitted to access the transmitter and operate the equipment.
- Always follow operating information as well as all applicable safety procedures and requirements.
- You must satisfy the age requirements in your country for operating the equipment.
- Store in a safe place.
- Keep a clear view of the work area at all time before using, check it is safe to do so

Before maintenance intervention on any remote controlled equipment

- Do not open the receiver enclosure unless you are qualified.
- Disconnect all electrical power from the equipment.
- Check the enclosure and cable for damage regularly, do not use if there is evidence of damage

Information sur la sécurité



Lisez attentivement les informations de sécurité suivantes avant de procéder à l'installation, l'utilisation ou la maintenance du produit RF Solutions. Le non-respect de ces avertissements peut entraîner la mort ou des blessures graves

- Ce système radio ne doit pas être utilisé dans des zones présentant un risque d'explosion
- Seul le personnel qualifié doit être autorisé à accéder à l'émetteur et à utiliser l'équipement.
- Suivez toujours les instructions d'utilisation ainsi que toutes les procédures et exigences de sécurité applicables.
- Vous devez satisfaire aux exigences d'âge dans votre pays pour utiliser l'équipement
- Il est strictement interdit d'utiliser l'équipement sous l'influence de drogues, d'alcool et/ou de médicaments.
- Conserver dans un endroit sûr.
- Gardez une vue dégagée sur la zone de travail à tout moment

Avant intervention de maintenance sur tout équipement télécommandé

- N'ouvrez pas le boîtier du récepteur à moins d'être qualifié
- Coupez toujours l'alimentation électrique de l'équipement.
- Vérifiez régulièrement que le boîtier et le câble ne sont pas endommagés, ne les utilisez pas s'il y a des preuves de dommages

Veiligheidsinformatie



Lees de volgende veiligheidsinformatie zorgvuldig door voordat u doorgaat met de installatie, bediening of het onderhoud van het RF Solutions-product. Het niet opvolgen van deze waarschuwingen kan de dood of ernstig letsel tot gevolg hebben

- Dit radiosysteem mag niet worden gebruikt in gebieden waar explosiegevaar bestaat.
- Alleen gekwalificeerd personeel mag toegang krijgen tot de zender en de apparatuur bedienen.
- Volg altijd de bedieningsinformatie en alle toepasselijke veiligheidsprocedures en -vereisten.
- U moet voldoen aan de leeftijdsvereisten in uw land voor het gebruik van de apparatuur.
- Bewaar op een veilige plaats.
- Houd te allen tijde een duidelijk zicht op het werkgebied voordat u het gebruikt, controleer of het veilig is om dit te doen

Vóór onderhoudsinterventie op op afstand bediende apparatuur

- Open de behuizing van de ontvanger niet tenzij u hiervoor gekwalificeerd bent.
- Koppel alle elektrische stroom van de apparatuur los.
- Controleer de behuizing en kabel regelmatig op beschadigingen, niet gebruiken als er tekenen van schade zijn

Battery Precautions

- Risk of explosion if battery is replaced with a battery of an incorrect type.
- Do not short-circuit, disassemble, deform or heat batteries.
- Never attempt to charge a visibly damaged or frozen battery.
- Do not use or charge the battery if it appears to be leaking, deformed or damaged in any way.
- Immediately discontinue use of the battery if, while using, charging, or storing the battery, the battery emits an unusual smell, feels hot, changes color, changes shape, or appears abnormal in any other way.
- Keep batteries out of reach of small children. Should a child swallow a battery, consult a physician immediately.

Précautions Concernant la Batterie

- Risque d'explosion si la batterie est remplacée par une batterie d'un type incorrect.
- Ne pas court-circuiter, démonter, déformer ou chauffer les batteries.
- N'essayez jamais de charger une batterie visiblement endommagée ou gelée.
- N'utilisez pas et ne chargez pas la batterie si elle semble fuir, déformée ou endommagée de quelque manière que ce soit.
- Cessez immédiatement d'utiliser la batterie si, lors de l'utilisation, du chargement ou du stockage de la batterie, la batterie émet une odeur inhabituelle, est chaude, change de couleur, change de forme ou semble anormale de toute autre manière.
- Gardez les piles hors de portée des jeunes enfants. Si un enfant avale une pile, consultez immédiatement un médecin.

Voorzorgsmaatregelen voor de batterij

- Explosiegevaar als de batterij wordt vervangen door een batterij van een onjuist type.
- Batterijen niet kortsluiten, demonteren, vervormen of verhitten.
- Probeer nooit een zichtbaar beschadigde of bevroren batterij op te laden.
- Gebruik of laad de batterij niet op als deze lekt, vervormd of op enigerlei wijze beschadigd is.
- Stop onmiddellijk met het gebruik van de batterij als de batterij tijdens het gebruik, het opladen of opslaan van de batterij een ongewone geur afgeeft, warm aanvoelt, van kleur verandert, van vorm verandert of er op een andere manier abnormaal uitziet.
- Houd batterijen buiten het bereik van kleine kinderen. Raadpleeg onmiddellijk een arts als een kind een batterij inslikt.

TRAP 8 Channel Remote Control Systems



RECEIVER — RX

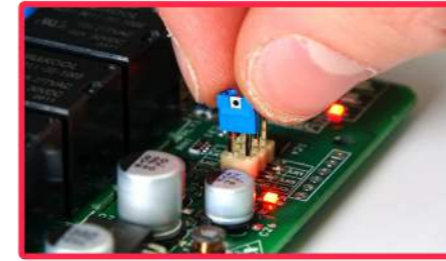

LK3



x1-5

FM	LoRa Mode 1	LoRa Mode 2	LoRa Mode 3	LoRa Mode 4
x1	x2	x3	x4	x5

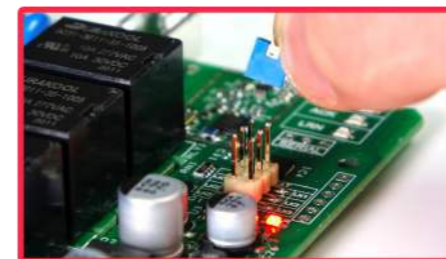
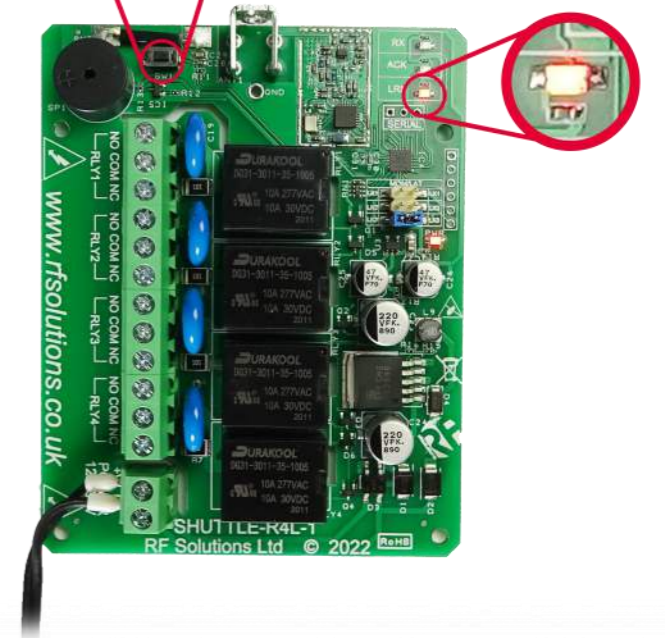

LoRa Mode 1 - 4

TRAP: 0-10KM



TRAP 8 Channel Remote Control Systems



Changing Modes of Operation—EXAMPLE

Modification des modes de fonctionnement—EXEMPLE

Bedieningsmodi wijzigen—VOORBEELD

Betriebsmodi ändern - BEISPIEL

Cambio de modos de funcionamiento—EJEMPLO

Modifica delle modalità di funzionamento: ESEMPIO



FM
0 - 2KM



TRANSMITTER — TX

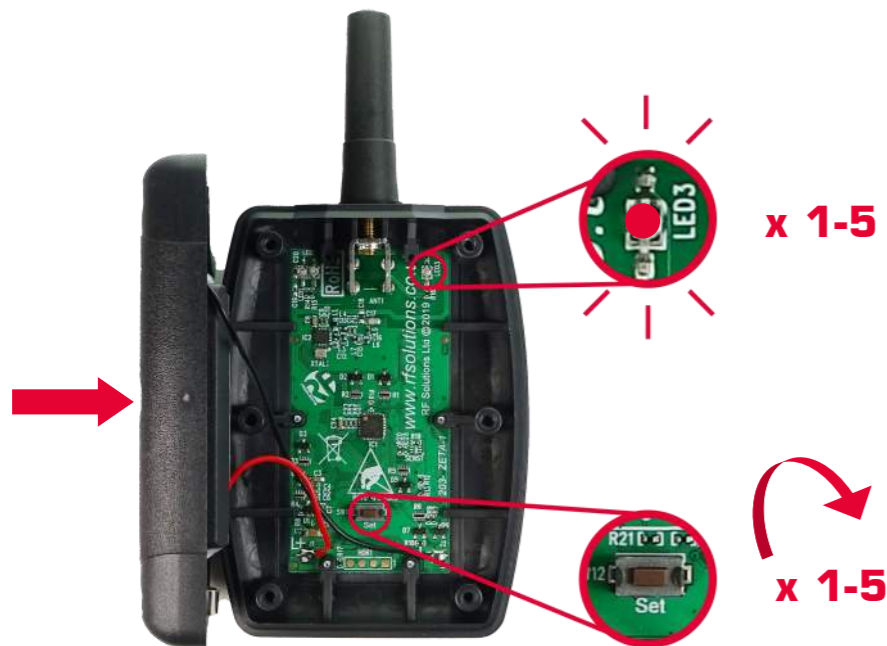
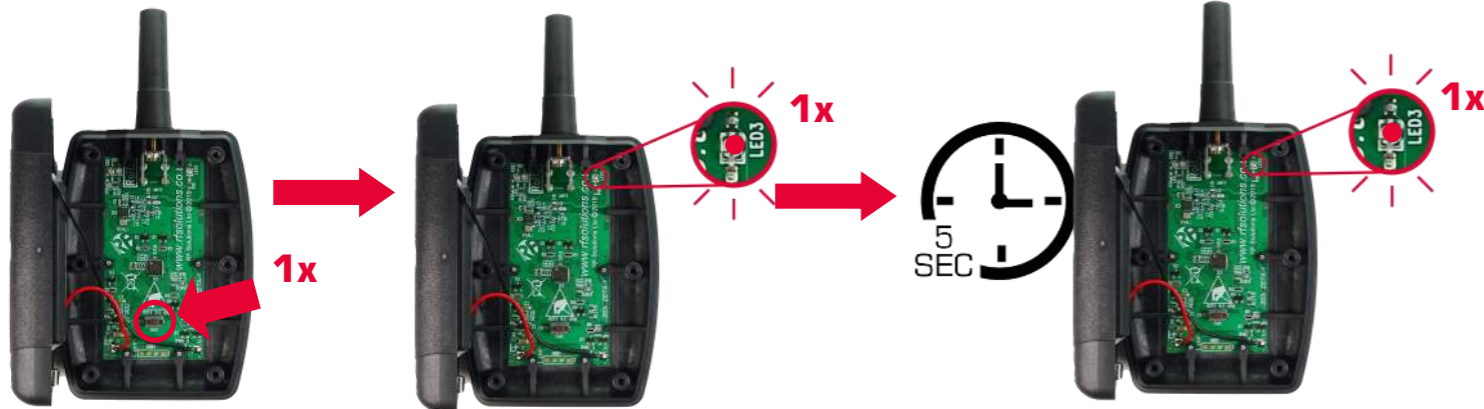

FLASH MODE

- 1 FM**
- 2 LoRa Mode 1**
- 3 LoRa Mode 2**
- 4 LoRa Mode 3**
- 5 LoRa Mode 4**

TRAP 8 Channel Remote Control Systems



Sicherheitsinformation



Lesen Sie die folgenden Sicherheitsinformationen sorgfältig durch, bevor Sie mit der Installation, dem Betrieb oder der Wartung des RF Solutions-Produkts fortfahren. Die Nichtbeachtung dieser Warnungen kann zum Tod oder zu schweren Verletzungen führen.

- Dieses Funksystem darf nicht in explosionsgefährdeten Bereichen eingesetzt werden.
- Nur qualifiziertem Personal sollte der Zugang zum Messumformer und die Bedienung des Geräts gestattet werden.
- Befolgen Sie immer die Betriebsinformationen sowie alle geltenden Sicherheitsverfahren und -anforderungen.
- Für den Betrieb des Geräts müssen Sie die Altersanforderungen Ihres Landes erfüllen.
- An einem sicheren Ort aufbewahren.
- Behalten Sie vor der Verwendung jederzeit freie Sicht auf den Arbeitsbereich und prüfen Sie, ob dies sicher ist.

Vor Wartungsarbeiten an ferngesteuerten Geräten

- Öffnen Sie das Empfängergehäuse nur, wenn Sie dafür qualifiziert sind.
- Trennen Sie die gesamte Stromversorgung vom Gerät.
- Gehäuse und Kabel regelmäßig auf Beschädigungen prüfen, bei Anzeichen von Beschädigungen nicht verwenden.

Información de seguridad



Lea atentamente la siguiente información de seguridad antes de continuar con la instalación, operación o mantenimiento del producto de RF Solutions. El incumplimiento de estas advertencias podría provocar la muerte o lesiones graves.

- Este sistema de radio no debe utilizarse en áreas donde exista riesgo de explosión.
- Solo se debe permitir el acceso al transmisor y operar el equipo a personal calificado.
- Siga siempre la información de funcionamiento, así como todos los procedimientos y requisitos de seguridad aplicables.
- Debe cumplir con los requisitos de edad en su país para operar el equipo.
- Almacenar en un lugar seguro.
- Mantenga una vista clara del área de trabajo en todo momento antes de usar, verifique que sea seguro hacerlo
- Antes de la intervención de mantenimiento en cualquier equipo controlado a distancia
- No abra la caja del receptor a menos que esté calificado.
- Desconecte toda la energía eléctrica del equipo.
- Compruebe la carcasa y el cable en busca de daños con regularidad, no los utilice si hay evidencia de daños

Informazioni sulla sicurezza



Leggere attentamente le seguenti informazioni sulla sicurezza prima di procedere con l'installazione, il funzionamento o la manutenzione del prodotto RF Solutions. La mancata osservanza di queste avvertenze può provocare morte o lesioni gravi

- Questo sistema radio non deve essere utilizzato in aree a rischio di esplosione.
- L'accesso al trasmettitore e l'utilizzo dell'apparecchiatura deve essere consentito solo a personale qualificato.
- Seguire sempre le informazioni operative, nonché tutte le procedure e i requisiti di sicurezza applicabili.
- È necessario soddisfare i requisiti di età nel proprio paese per l'utilizzo dell'apparecchiatura.
- Conservare in un luogo sicuro.
- Mantenere sempre una visione chiara dell'area di lavoro prima dell'uso, controllare che sia sicuro farlo

Prima dell'intervento di manutenzione su qualsiasi apparecchiatura telecomandata

- Non aprire l'involucro del ricevitore se non si è qualificati.
- Scollegare tutta l'alimentazione elettrica dall'apparecchiatura.
- Controllare regolarmente la custodia e il cavo per verificare che non siano danneggiati, non utilizzare se vi sono segni di danneggiamento

Vorsichtsmaßnahmen für den Akku

- Explosionsgefahr, wenn die Batterie durch eine Batterie eines falschen Typs ersetzt wird.
- Batterien nicht kurzschließen, zerlegen, verformen oder erhitzen.
- Versuchen Sie niemals, eine sichtbar beschädigte oder eingefrorene Batterie aufzuladen.
- Verwenden oder laden Sie den Akku nicht, wenn er undicht, deformiert oder in irgendeiner Weise beschädigt ist.
- Stellen Sie die Verwendung des Akkus sofort ein, wenn der Akku während des Gebrauchs, Aufladens oder Lagerns einen ungewöhnlichen Geruch verströmt, sich heiß anfühlt, seine Farbe ändert, seine Form ändert oder auf andere Weise ungewöhnlich erscheint.
- Bewahren Sie Batterien außerhalb der Reichweite von kleinen Kindern auf. Sollte ein Kind eine Batterie verschlucken, suchen Sie sofort einen Arzt auf.

Batterivarningar

- Risiko de explosión si se reemplaza la batería por una de tipo incorrecto.
- No cortocircuite, desmonte, deforme ni caliente las baterías.
- Nunca intente cargar una batería visiblemente dañada o congelada.
- No utilice ni cargue la batería si parece tener una fuga, estar deformada o dañada de alguna manera.
- Interrumpa inmediatamente el uso de la batería si, al usar, cargar o almacenar la batería, la batería emite un olor inusual, se siente caliente, cambia de color, cambia de forma o tiene un aspecto anormal de alguna otra manera.
- Mantenga las baterías fuera del alcance de los niños pequeños. Si un niño se traga una batería, consulte a un médico de inmediato.

Precauzioni per la batteria

- Rischio di esplosione se la batteria viene sostituita con una di tipo errato.
- Non cortocircuitare, smontare, deformare o surriscaldare le batterie.
- Non tentare mai di caricare una batteria visibilmente danneggiata o congelata.
- Non utilizzare o caricare la batteria se sembra perdere, deformata o danneggiata in alcun modo.
- Interrompere immediatamente l'uso della batteria se, durante l'utilizzo, la ricarica o la conservazione della batteria, la batteria emette un odore insolito, è calda, cambia colore, cambia forma o appare anormale in qualsiasi altro modo.
- Tenere le batterie fuori dalla portata dei bambini piccoli. Se un bambino ingerisce una batteria, consultare immediatamente un medico.

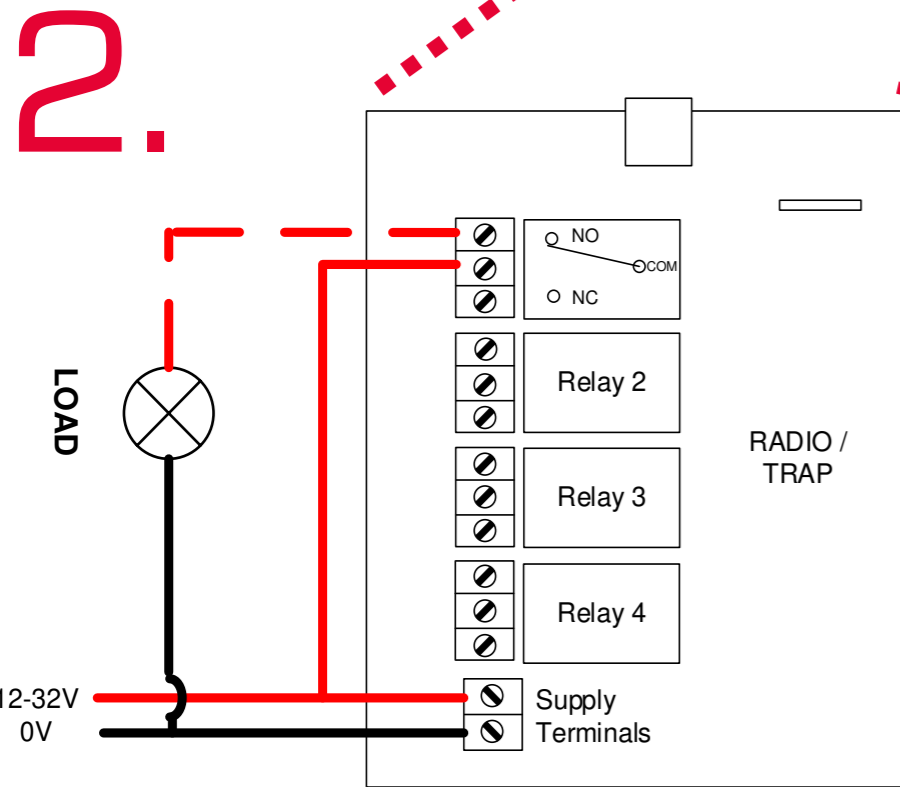
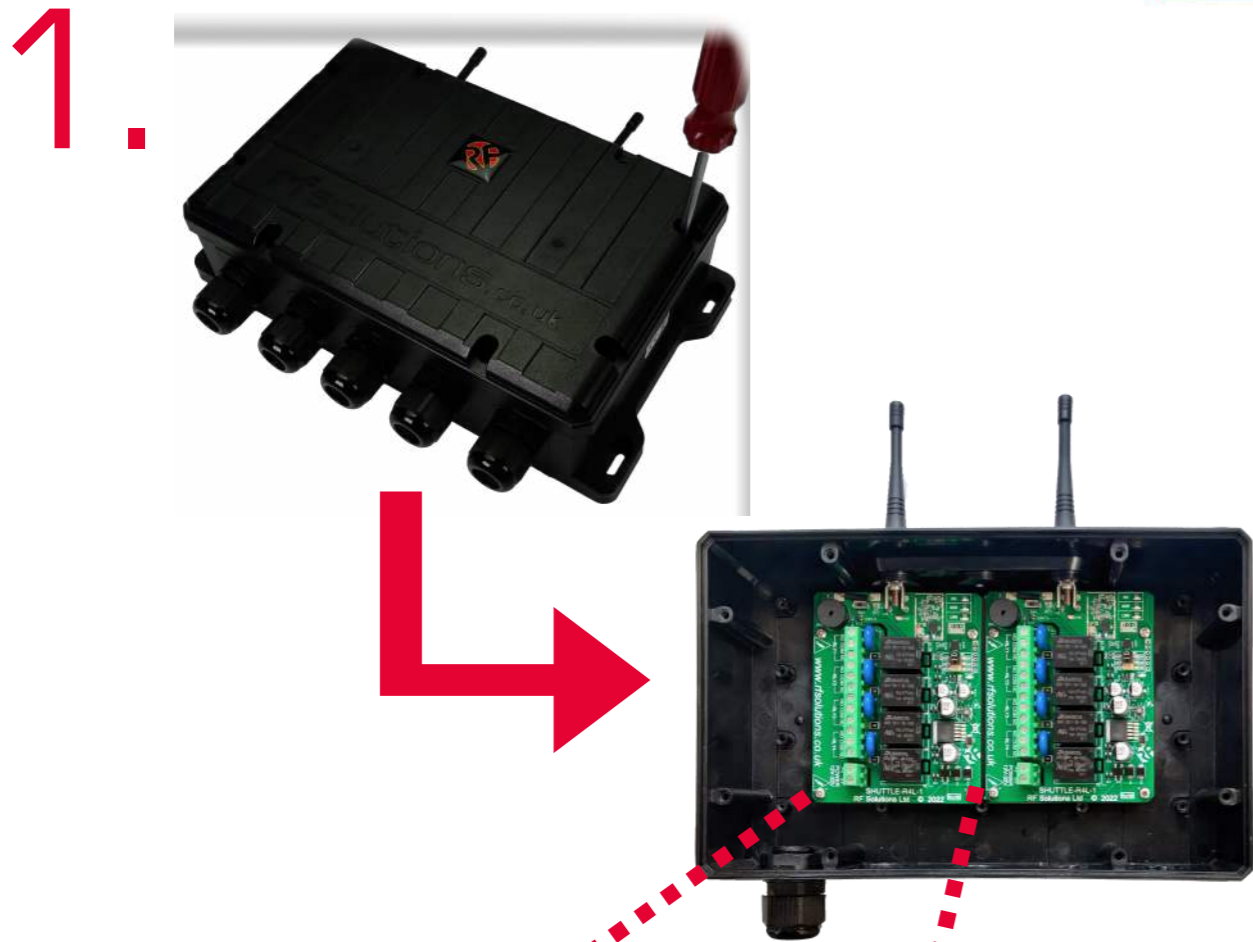

Wiring Example
Exemple de câblage
Bedradingsvoorbeeld
Verdrahtungsbeispiel
Ejemplo de cableado
Esempio di cablaggio

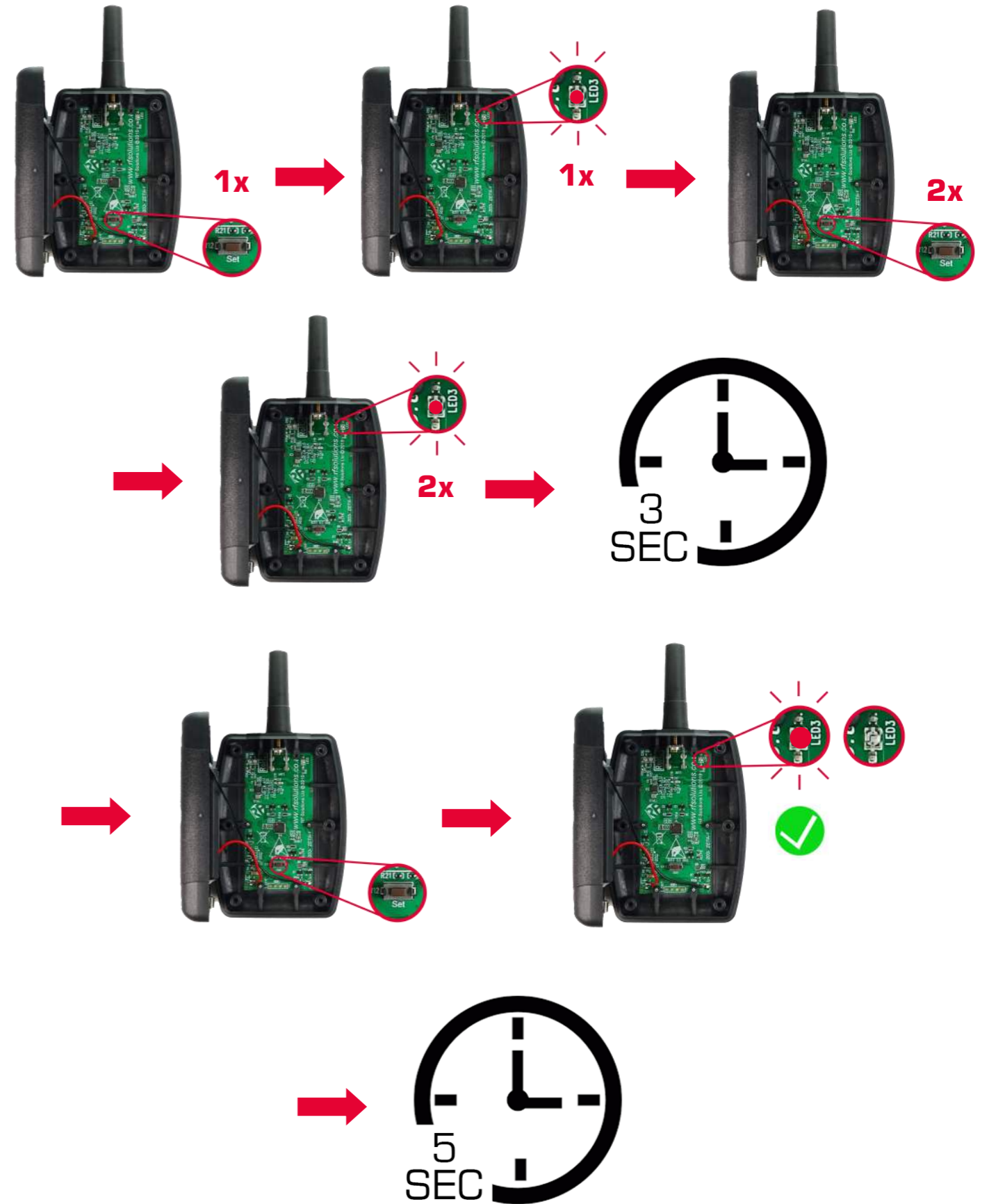

TRAP 8 Channel Remote Control Systems



Setting Acknowledgement Feature
Réglage de la fonction d'accusé de réception
Bevestigingsfunctie instellen
Quittungsfunktion einstellen
Configuración de la función de reconocimiento
Impostazione della funzione di riconoscimento

ACKNOWLEDGEMENT = PAIRED RELAY OPERATED

NO ACKNOWLEDGEMENT = SIGNAL FAILED

TRAP 8 Channel Remote Control Systems



3.

Setting Momentary / Action
Réglage du relais momentané / verrouillage
Instelling relais kortstondig/vergrendelend
Relais kurzzeitig / selbsthaltend einstellen
Ajuste del relé momentáneo / enclavado
Impostazione del relè momentaneo/a scatto

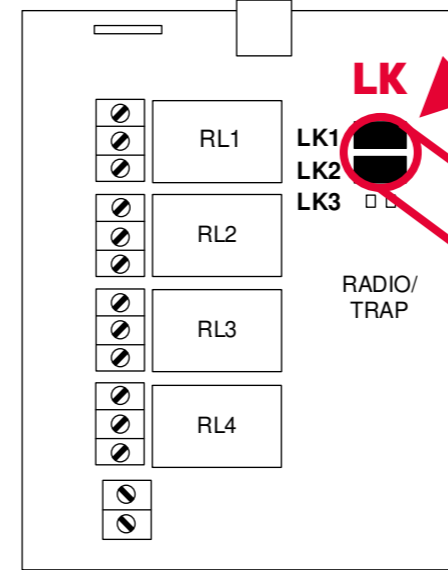

LK	RL1	RL2	RL3	RL4
LK1 LK2	1/2 SEC	1/2 SEC	1/2 SEC	1/2 SEC
LK1 LK2	MOMENTARY	MOMENTARY	MOMENTARY	MOMENTARY
LK1 LK2	LATCHING	LATCHING	LATCHING	LATCHING
LK1 LK2	MOMENTARY	MOMENTARY	LATCHING	LATCHING
LK1 LK2	MOMENTARY	MOMENTARY	MOMENTARY	MOMENTARY

MOMENTARY

LATCHING

TRAP 8 Channel Remote Control Systems



Pairing Additional Transmitters
Couplage d'émetteurs supplémentaires
Extra zenders koppelen
Koppeln zusätzlicher Sender
Emparejamiento de transmisores adicionales
Associazione di trasmettitori aggiuntivi



X 1

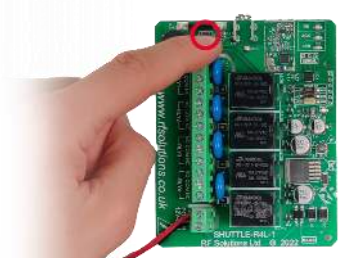

X 2

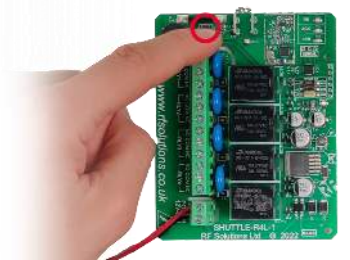

Maximum 30 Pairings
Maximum 30 appariements
Maximaal 30 paren
Maximal 30 Paarungen
Máximo 30 emparejamientos
Massimo 30 abbinamenti

TRAP 8 Channel Remote Control Systems



Erase all Pairings
Effacer tous les appariements
Alle koppelingen wissen
Alle Kopplungen löschen
Borrar todos los emparejamientos
Cancella tutti gli abbinamenti

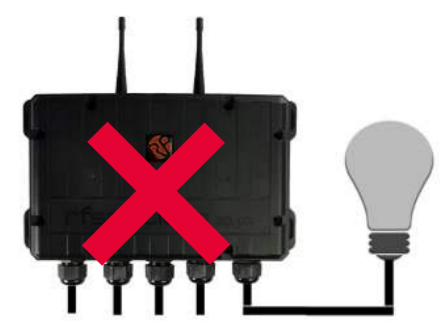
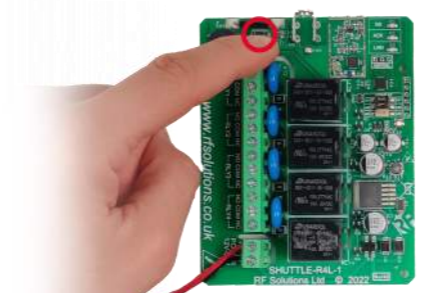

3 x AAA

