

LOC	DIST	REV	DATE	BY	APPD
A1	-	E	25MAR2002	BVS	MD
		F	01MAR2007	HM	GS

KEYINGS

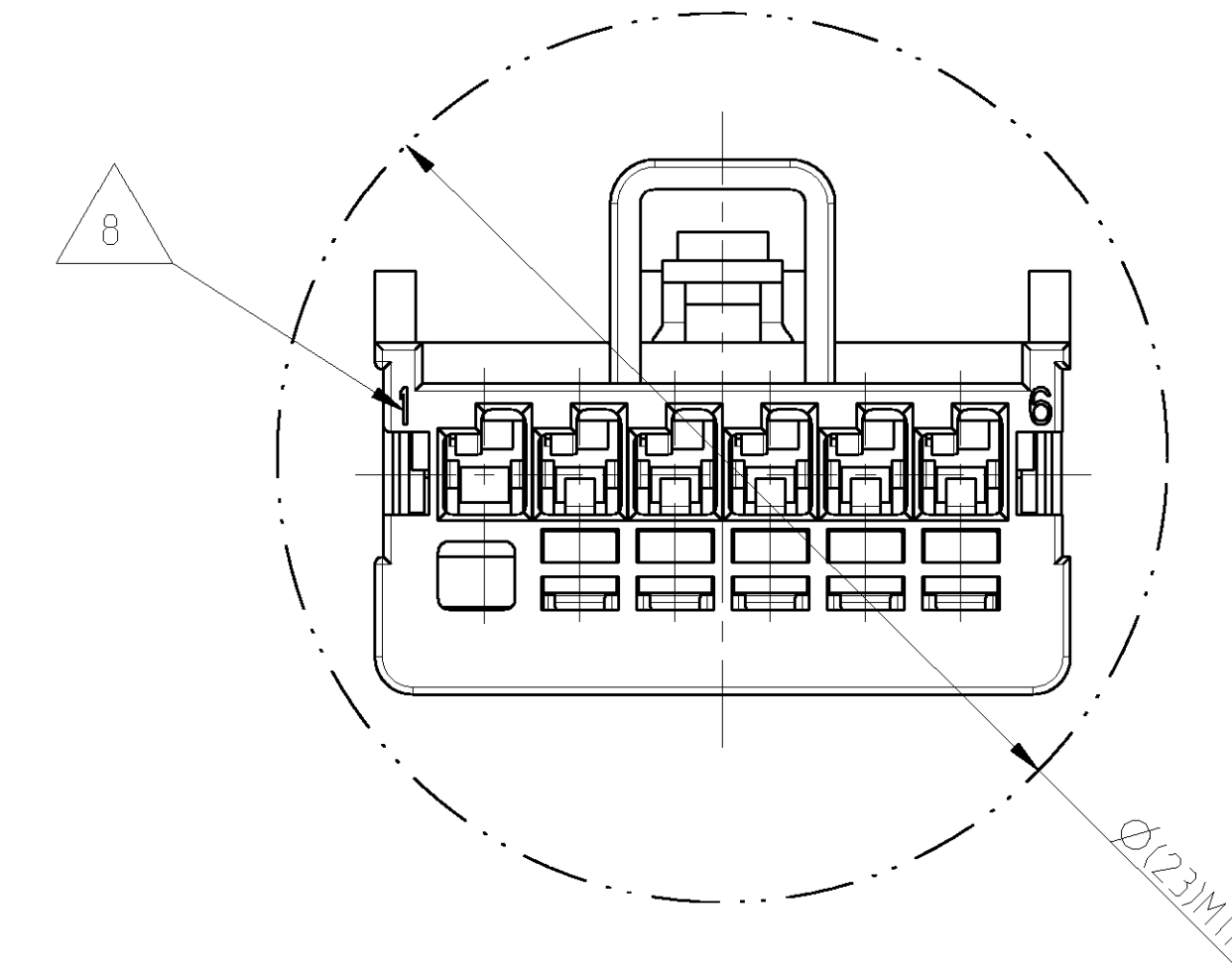
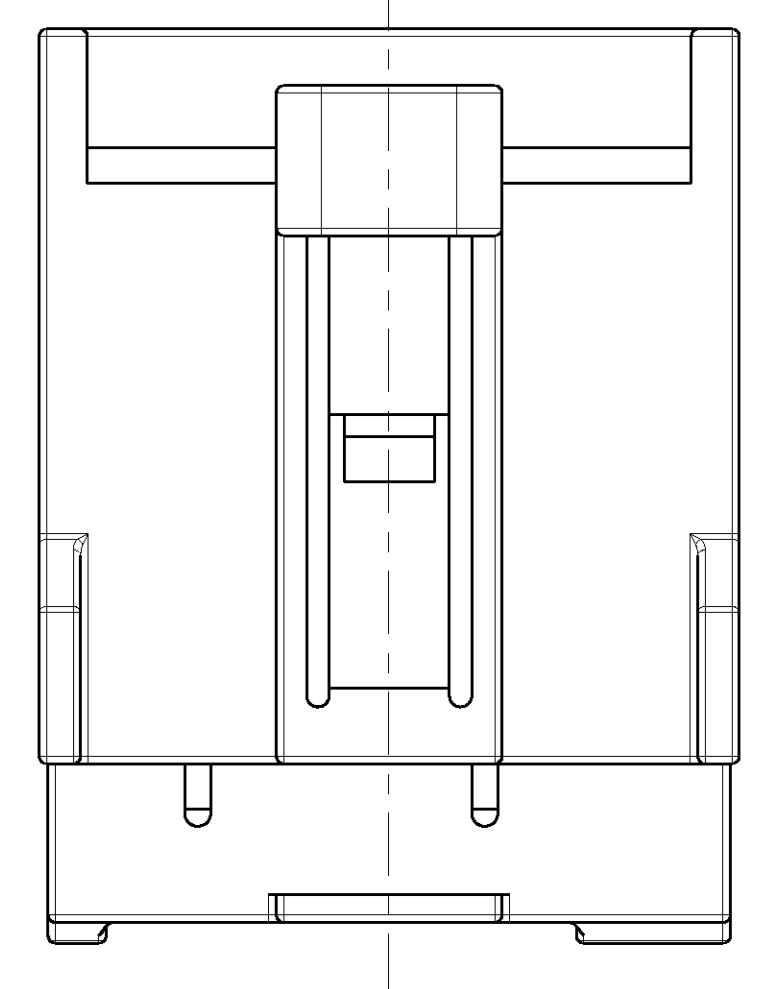
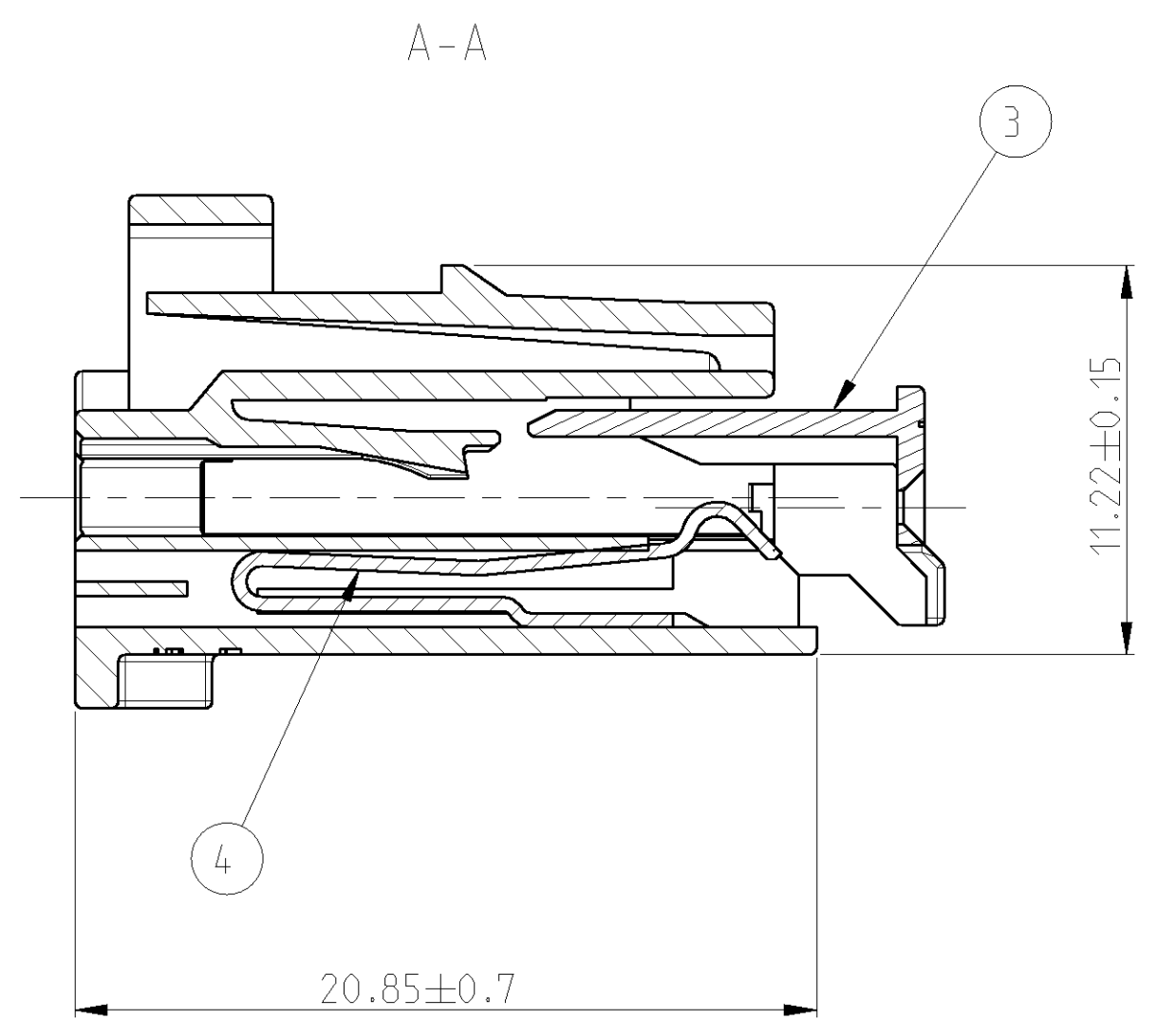
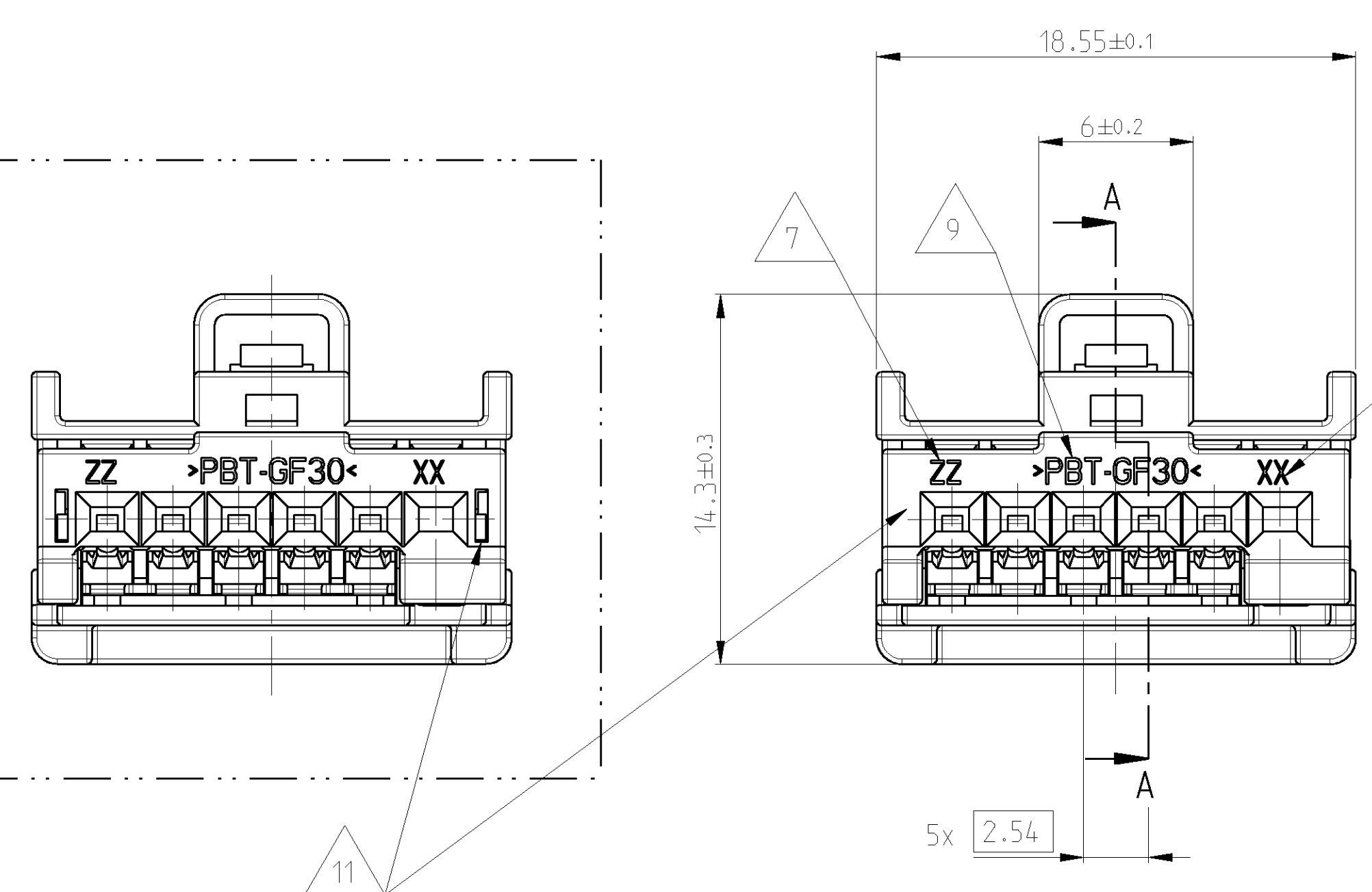
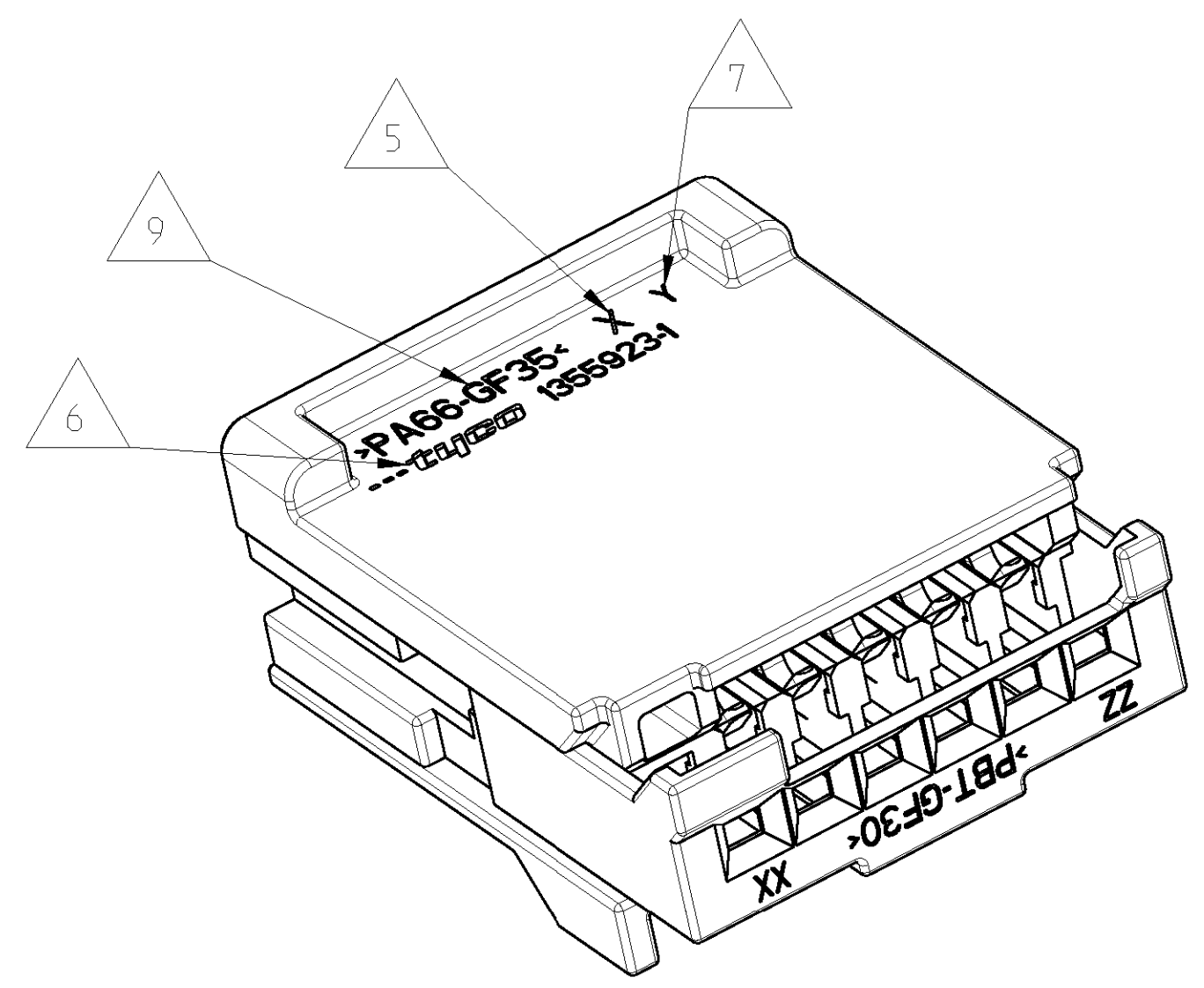
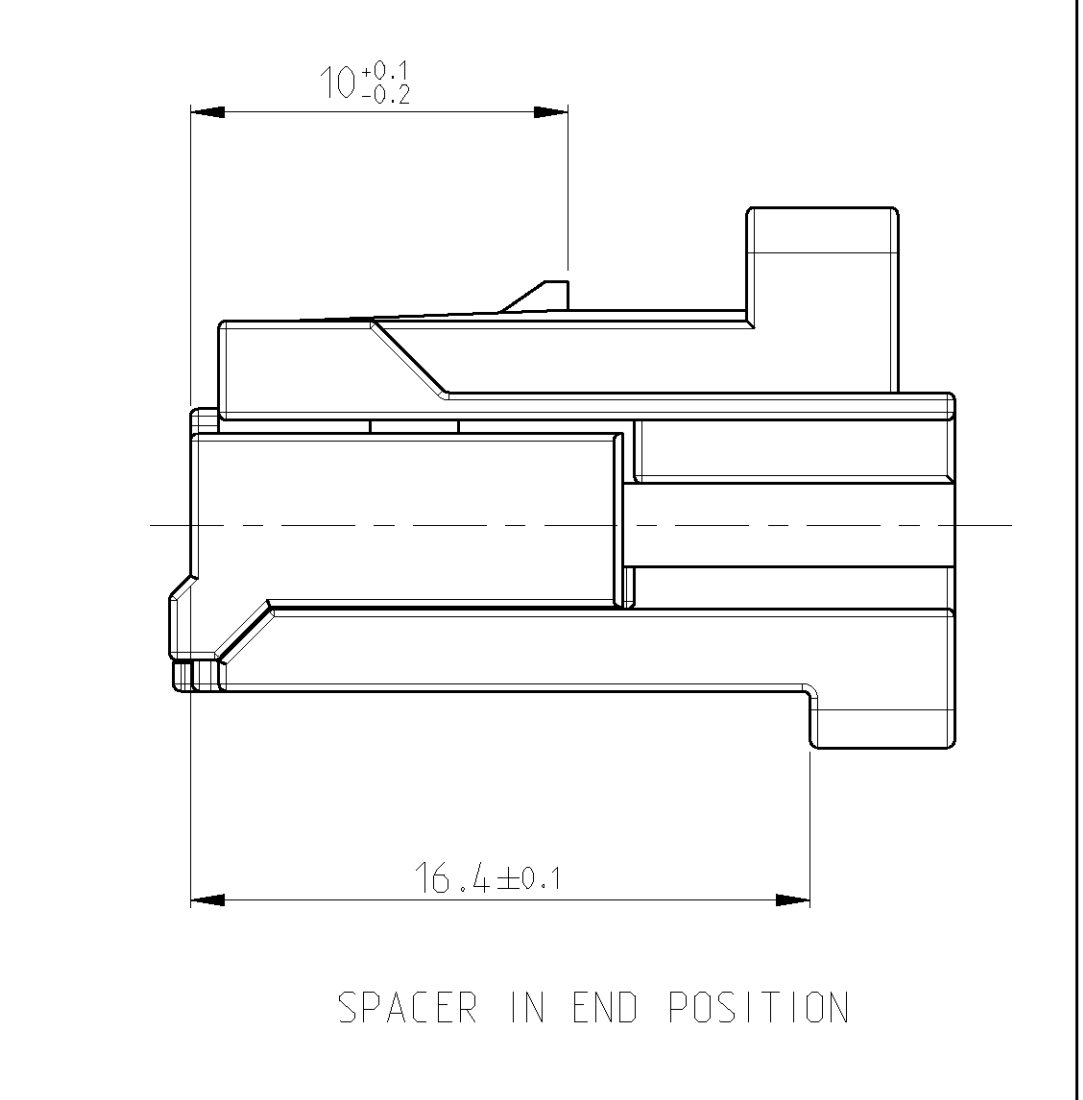
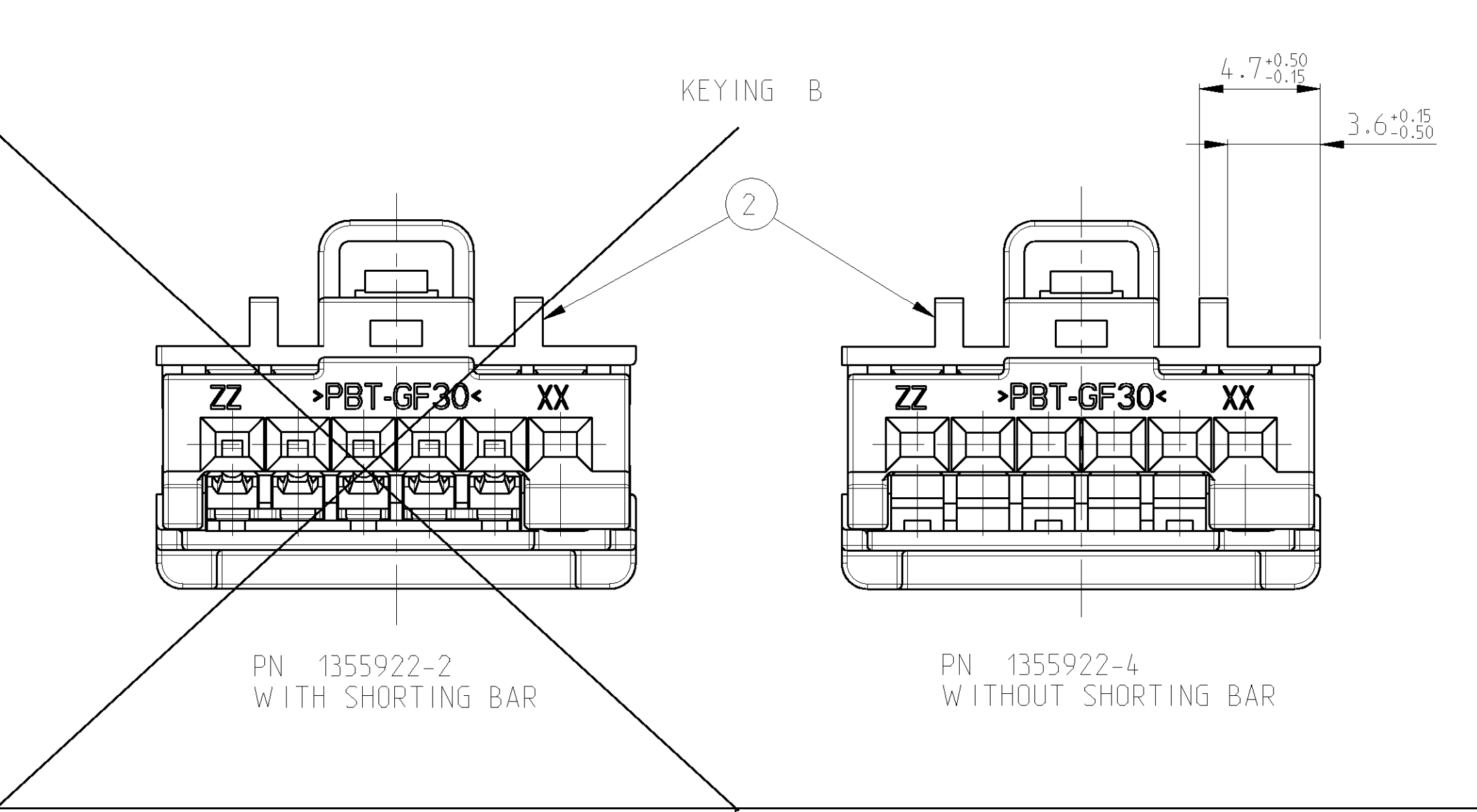
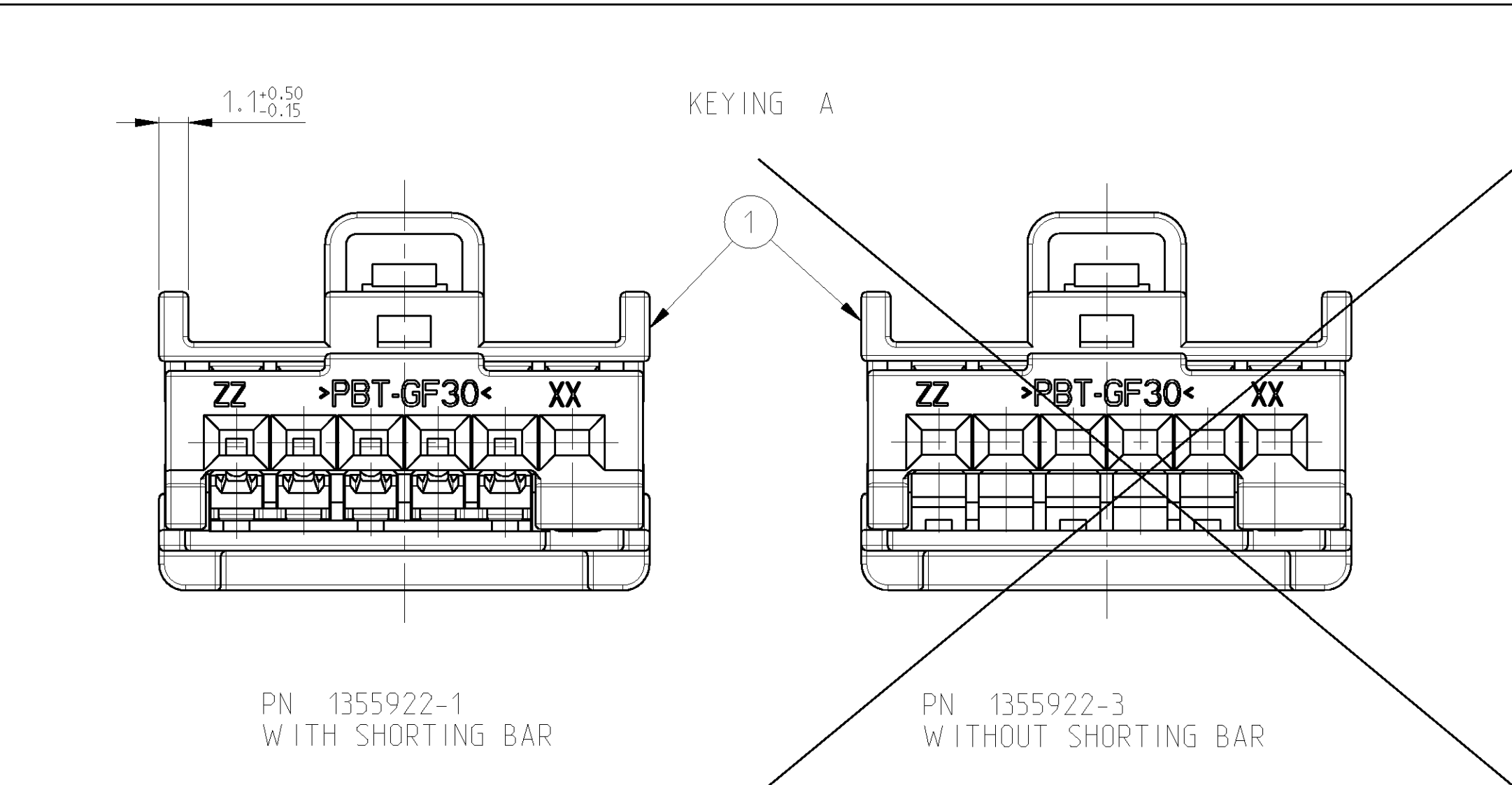

- NOTES**
Bemerkungen
- INTERFACE DRAWING: 114-18454
Schnittstellenzeichnung: 114-18454
 - APPLICABLE TERMINAL PART NUMBERS:
Bestell-Nr. passender Buchsenkontakte:
0-1393367-1 TIN 0.22-0.35mm²
0-1393366-1 TIN 0.50-0.75mm²
0-1393364-1 GOLD 0.22-0.35mm²
0-1393365-1 GOLD 0.50-0.75mm²
 - COMPATIBLE WIRE SPECIFICATIONS: WSK-MIL135-A1 & A2 (SAE)
WSK-MIL126-A1, A2 & A3 (METRIC)
WSB-MIL134-A1 (SAE)
WSK-MIL124-A (METRIC)
 - SPACER SHIPPED IN ITS PRE-ASSEMBLED
Spacer in Vorrast-Position montiert
 - PRODUCT REVISION LEVEL HOUSING
Teile Revision Gehäuse
 - TYCO LOGO
Tyco Logo
 - Y = TOOL NUMBER (OPTIONAL), ZZ = CAVITY NUMBER
Y = Werkzeug-Nr. (optional), ZZ = Nestnummer
 - TERMINAL CAVITY IDENTIFICATION NUMBER
Kontakt-Kammerbezeichnung
 - MATERIAL IDENTIFICATION
Materialkennzeichnung
 - PACKAGING:
77 PARTS PER TRAY
8 TRAY PER SHIPPING CONTAINER
 - SPACER DESIGN OPTIONAL
Spacergestaltung optional

TYCO ORDER NUMBER	KEY	REV.	DESCRIPTION	CODING	COLOUR/FINISH	MATERIAL	ITEM
1355922-4	B						
1355922-2							
1355922-3	A						
1355922-1							
		1	SHORTING BAR		Sn	X12CrNi17.7	4
		1	SPACER		RED	PBT-GF30	3
		1	FEMALE HOUSING, 6POS.	B	BLACK	PA66-GF35	2
		1	FEMALE HOUSING, 6POS.	A	YELLOW	PA66-GF35	1
			DESCRIPTION	CODING	COLOUR/FINISH	MATERIAL	ITEM

DIMENSIONS: mm 	TOLERANCES UNLESS OTHERWISE SPECIFIED: 0 PLC ± 1 PLC ± 2 PLC ± 3 PLC ± 4 PLC ± ANGLES ± MATERIAL - FINISH -	DWG: 114-18454 ENR: B. VAN SEBROECK B. VAN SEBROECK G. STEINBACH DATE: 25MAR2002 NAME: 1x6POS. GET FEMALE CONNECTOR, WITH OR WITHOUT SHORTING BAR SCALE: 5:1 SHEET: 1 OF 1 REV: F	tyco Electronics Tyco Electronics AMP GmbH 64625 Bensheim (Germany)
-----------------------	---	---	--