

Future Technology Devices International

Datasheet

FT51A-EVM Development Module



FT51A-EVM is an FT51A development module with the following features: display, heart-rate monitor, temperature sensor and force sensitive resistor.

1 Introduction

The FT51A-EVM is a development module for FTDI's FT51AQ, one of the devices from FTDI's range of 8-bit microcontrollers with USB interface bridging features integrated. FT51A is a MCU which includes the following features: USB client and USB hub interfaces, 8051 core, 8-bit ADC, UART, SPI, I²C, 245 FIFO and PWM.

The FT51A-EVM demonstrates the FT51A series I²C and SPI interfaces, the ADC input, PWM and GPIO features. It contains a 28 pin header which allows easy access to all the FT51AQ's IO pins, as well as the debug and reset pins. This module also comes preloaded with the FT51A-EVM firmware that allows users to use all the features of the module without developing firmware.

1.1 Features

The FT51A-EVM is fitted with a FT51AQ; many of the features of the FT51A series can be utilized with this module. For a full list of the FT51A series features please see the FT51A datasheet which can be found by clicking [here](#).

In addition to the features listed in the FT51A datasheet, the FT51A-EVM has the following features:

- 20 X 2 characters, LCD display, with I²C interface and RGB backlight.
- Heart-Rate Monitor with filtered and amplified analogue output
- Force sensitive resistor
- SPI temperature sensor
- Push buttons controls and LED indicator
- Interface footprints to allow for communication with FTDI's FT8xx modules and TTL-232R cables
- Upstream and downstream USB ports which allows for direct connection cascading.
- Debugger interface header used for debugging and programming the FT51AQ. Designer for operation with FTPD-1. See [FTPD-1 datasheet](#) for details about this module.
- Onboard jumper for configuring the module to be in self powered or USB powered.

Neither the whole nor any part of the information contained in, or the product described in this manual, may be adapted or reproduced in any material or electronic form without the prior written consent of the copyright holder. This product and its documentation are supplied on an as-is basis and no warranty as to their suitability for any particular purpose is either made or implied. Future Technology Devices International Ltd will not accept any claim for damages howsoever arising as a result of use or failure of this product. Your statutory rights are not affected. This product or any variant of it is not intended for use in any medical appliance, device or system in which the failure of the product might reasonably be expected to result in personal injury. This document provides preliminary information that may be subject to change without notice. No freedom to use patents or other intellectual property rights is implied by the publication of this document. Future Technology Devices International Ltd, Unit 1, 2 Seaward Place, Centurion Business Park, Glasgow G4 1 1HH United Kingdom. Scotland Registered Company Number: SC136640

Table of Contents

1	Introduction	1
1.1	Features	1
2	Driver Support	3
3	Ordering Information	4
4	FT51A-EVM Signals and Configurations.....	5
4.1	FT51A-EVM Pin Out	5
4.2	Connector Descriptions	6
4.3	I/O Pin Feature Options	10
5	Module Configurations	11
5.1	Jumper Configuration Options	11
6	Using Preloaded Firmware.....	12
7	Programming Firmware to the MTP Memory.....	13
8	Module Dimensions	14
9	UMFT51AA Module Circuit Schematic	15
10	Contact Information.....	20
Appendix A – References		18
Document References		18
Acronyms and Abbreviations		18
Appendix B – List of Figures and Tables.....		19
List of Figures		19
List of Tables		19
Appendix C – Revision History.....		20

2 Driver Support

Driver support for the FT51A USB Device Firmware Updater (DFU) is available as part of the FT51A SDK and is available for the following OS:

- Windows 10 32,64-bit
- Windows 8.1 32,64-bit
- Windows 8 32,64-bit
- Windows 7 32,64-bit

The DFU driver files can be found at the following PC location once the FT51A SDK has been installed:

C:\Users*Username*\Documents\FTDI\FT51A_SDK*version*\drivers

NOTE: "username" will be different for each user that logs into a PC.

3 Ordering Information

Module Code	Utilised IC Code	Description
UMFT51A-EVM	FT51AQ	FT51A evaluation platform

Other modules in the FT51A range:

Module Code	Utilised IC Code	Description
UMFT51AA-01	FT51AQ	8051 compatibility module.

4.2 Connector Descriptions

Pin No.	Name	Type	Description
CN1-1 and CN1-4	NC	Not Connected	Floating pin.
CN1-2	VCC5V	Power	5 volt power input. (Protected by zenor diode.)
CN1-3	RESET#	Signal	Active low reset
CN1-5	DBG	Signal	Debugger data line, single line half-duplex UART.
CN1-6	GND	Ground	0 volt ground.

Table 4.1 – Debugger Port Pin Out Description

Pin No.	Name	Type	Description
CN2-1	VCC	Power	5 volt power input.
CN2-2	GND	Ground	0 volt ground.

Table 4.2 – Power Port Pin Out Description

Pin No.	Name	Type	Description
CN3-1	VBUS	Power	5 volt power output.
CN3-2	DM	Signal	USB Data - to downstream device
CN3-3	DP	Signal	USB Data + to downstream device
CN3-4	GND	Ground	0 volt ground.

Table 4.3 – Downstream USB Port Pin Out Description

Pin No.	Name	Type	Description
CN4-1	GND	Ground	0 volt ground.
CN4-2	UART_RTS#	Signal	UART Ready to Send output. Active low.
CN4-3	NC	NC	No Connect
CN4-4	UART_RX	Signal	UART RX Data input.
CN4-5	UART_TX	Signal	UART TX Data output.
CN4-6	UART_CTS#	Signal	UART Clear to Send input. Active low.

Table 4.4 – UART Port Pin Out Description

Note: CN4 is not fitted by default.

Pin No.	Name	Type	Description
CN5-1	VBUS	Power	5 volt power input. To enable bus power mode close JP1
CN5-2	DM	Signal	USB Data - from upstream device
CN5-3	DP	Signal	USB Data + from upstream device
CN5-4	GND	Ground	0 volt ground.

Table 4.5 – Upstream USB Port Pin Out Description

Pin No.	Name	Type	Description
CN6-1	VCC3V3	Power	3.3 volt power output
CN6-2	VCC5V	Power	5 volt power output
CN6-3	DBG	Signal Input/Output	Debugger interface pin, bi-directional, open-drain output with on-board pull-up resistor
CN6-4	RST	Signal Input	FT51A reset pin, active high
CN6-5	AIO0	I/O Signals	JP4 1-2 short: Unused analog IO pin JP4 2-3 short: No connection
CN6-6	SW 1	Signal Input	(DIO0) Active low when SW 1 pressed.
CN6-7	AIO1	I/O Signals	Unused analog IO pin
CN6-8	FSR_LED	Signal Output	(DIO1) Drive the LED indicating FSR pressure.
CN6-9	AIO2	I/O Signals	Unused analog IO pin
CN6-10	DIO2	Signal Output	When connecting the FT51A-EVM to a FTDI FT800, DIO2 can be used as the SPI master CS# net.
CN6-11	AIO3	I/O Signals	Unused analog IO pin
CN6-12	SPI MOSI	Signal output	(DIO3) Master Out, Slave In SPI signal
CN6-13	AIO4	I/O Signals	Unused analog IO pin
CN6-14	SPI MISO	Signal input	(DIO4) Master In, Slave Out SPI signal
CN6-15	AIO5	I/O Signals	Unused analog IO pin
CN6-16	SPI SCLK	Signal output	(DIO5) SPI clock output
CN6-17	AIO6	I/O Signals	Unused analog IO pin

Pin No.	Name	Type	Description
CN6-18	DIO6	Signal Output	Can be used as SPI CS# to temperature sensor, can be over written by jumper JP2.
CN6-19	SW3	Signal Input	(AIO7) Active low when SW3 pressed.
CN6-20	SW2	Signal Input	(DIO7) Active low when SW2 pressed.
CN6-21	SW4	Signal Input	(AIO8) Active low when SW4 pressed.
CN6-22	LCD_RST#	Signal Output	(DIO8) Controls the reset feature of the LCD module
CN6-23	AIO9	I/O Signals	Unused analog IO pin
CN6-24	DIO9	Signal I/O	Unused digital IO.
CN6-25	AIO10	I/O Signals	JP3 1-2 short: Unused analog IO pin JP3 2-3 short: No connection
CN6-26	UART RTS#	Output signal	(DIO10) UART Ready To Send signal. Active low.
CN6-27	HB_LED	Signal Output	(AIO11) Used to drive the on board heartbeat indicator LED
CN6-28	UART RX	Signal Input	(DIO11) UART data receive signal
CN6-29	LCD_PWM (R)	Signal Output	(AIO12) control the LCD backlight red signal
CN6-30	UART CTS#	Signal Input	(DIO12) UART clear to send signal input. Active low.
CN6-31	LCD_PWM (G)	Signal Output	(AIO13) control the LCD backlight green signal
CN6-32	I2C_SCL	Signal Output	(DIO13) I ² C clock output. Used to communicate with the LCD display
CN6-33	LCD_PWM (B)	Signal Output	(AIO14) control the LCD backlight blue signal
CN6-34	I2C_SDA	Signal IO	(DIO14) Bidirectional I ² C data line. Used to communicate with the LCD display
CN6-35	VBUS_PWR	Signal Input	(AIO15) Indicates if power is present on USB bus
CN6-36	UART TX	Signal	(DIO15) UART TX signal output. Active low.
CN6-37, CN6-38	GND	Ground	0V Ground
CN6-39, CN6-40	NC	-	No connection

Table 4.6 – Module IO Pin Out Description

Note: The term “Unused” means the IO pin is not used by the on-board electronics. These IOs are free to be used by user’s add-on circuit.

Pin No.	Name	Type	Description
CN7-1	SPI_SCLK	Signal	SPI CLK output
CN7-2	SPI_MOSI	Signal	SPI Master Output Slave Input. Output signal
CN7-3	SPI_MISO	Signal	SPI Master Input Slave Output. Input signal
CN7-4	CS#	Signal	Active low EVE chip select signal output
CN7-5	INT#	Signal	Active low EVE interrupt signal input
CN7-6	PD#	Signal	Active low EVE power down signal output
CN7-7	5V	Power	5V power output
CN7-8	NC	-	No connection
CN7-9	GND	GND	Ground 0 volts.
CN7-10	GND	GND	Ground 0 volts.

Table 4.7 – EVE/SPI Pin Out Description

Note: CN7 is not fitted by default.

4.3 I/O Pin Feature Options

The following features can be configured using the FT51A's multiplexer to bring signal to the available pins.

FT51A IO Signal Option	Available On Pin	Description
GPIO	DIO0-15 and AIO0-15	General purpose IO
ADC	AIO0-15	8-bit analog to digital converter
UART	DIO0-15	UART interface. Data rates up to 3 Mbaud.
SPI Master	DIO0-15	SPI master interface. Clock frequency up to 24MHz
SPI Slave	DIO0-15	SPI slave interface
245 FIFO	DIO0-15	8 bit parallel data interface with handshake. Data rates up to 7MB/s.
I ² C Master	DIO0-15	I ² C master interface. Data rates up to 3.4Mb/s
I ² C Slave	DIO0-15	I ² C slave interface
PWM	DIO0-15 and AIO0-15	Pulse Width Modulation output.
BCD Detect	DIO0-15 and AIO0-15	Indicates a dedicated charger port has been detected on upstream USB port.

Table 4.8 – I/O Signal Options

5 Module Configurations

5.1 Jumper Configuration Options

Solder Link No.	Setting	Status	Description
JP1	2-3	Non-Default	Self-Powered mode. This setting removes the connection between VBUS and VCC5V. For self-powered operation 5V power is received from CN2-1.
JP1	1-2	Default	Bus-Powered mode. This setting creates a connection between VBUS and VCC5V. For bus-powered operations 5V power will be outputted from CN2-1 when the module is connected to an upstream USB port.

Table 5.1 – Jumper JP1 Modes

Solder Link No.	Setting	Status	Description
JP2	1-2	Non-Default	Disable the temperature sensor's SPI outputs.
JP2	2-3	Default	Allow the FT51A to control the CS# line of the temperature sensor.

Table 5.2 – Jumper JP2 Modes

Solder Link No.	Setting	Status	Description
JP3	1-2	Non-Default	Disable the heart rate monitor.
JP3	2-3	Default	Allow the FT51A to monitor the heart rate sensor output.

Table 5.3 – Jumper JP3 Modes

Solder Link No.	Setting	Status	Description
JP4	1-2	Non-Default	Disable the force sensitive resistor.
JP4	2-3	Default	Allow the FT51A to monitor the force sensitive resistor.

Table 5.4 – Jumper JP4 Modes

6 Using Preloaded Firmware

The preloaded firmware of the FT51A_EVM evaluation module will display sensor data on the LCD panel. The data which is displayed is from the temperature sensor (U4).

This firmware may be replaced either via the debugger / programmer module FTPD-1 using supplied code from FTDI or with the users own application.

Alternatively as the default firmware includes DFU (Device Firmware Update) on the upstream USB port the firmware may be reprogrammed over USB using the DFU.

7 Programming Firmware to the MTP Memory

The FT51AQ of the FT51A-EVM is programmed with the FT51A-EVM firmware which allows users to interface with the temperature sensor.

For users wishing to apply their own code or other supplied examples, the FT51AQ can be programmed using the FTPD-1 or over USB using DFU. Connector CN-1 is used as a dedicated port that interfaces with the FTPD-1.

A list of available examples (at time of writing) is shown below and source code can be found in 'C:\Users\Username\Documents\FTDI\FT51A_SDK\version\examples' after installing the FT51A SDK:

- AN_344_FT51A_DFU_Sample
- AN_345 FT51A Keyboard Sample
- AN_346 FT51A Mouse Sample
- AN_347 FT51A Test and Measurement Sample
- AN_348 FT51A FT800 Sensors Sample
- AN_349 FT51A FT800 Spaced Invaders Sample
- AN_351 FT51A Compatibility Module
- AN_354 FT51A Standalone Demo Application

8 Module Dimensions

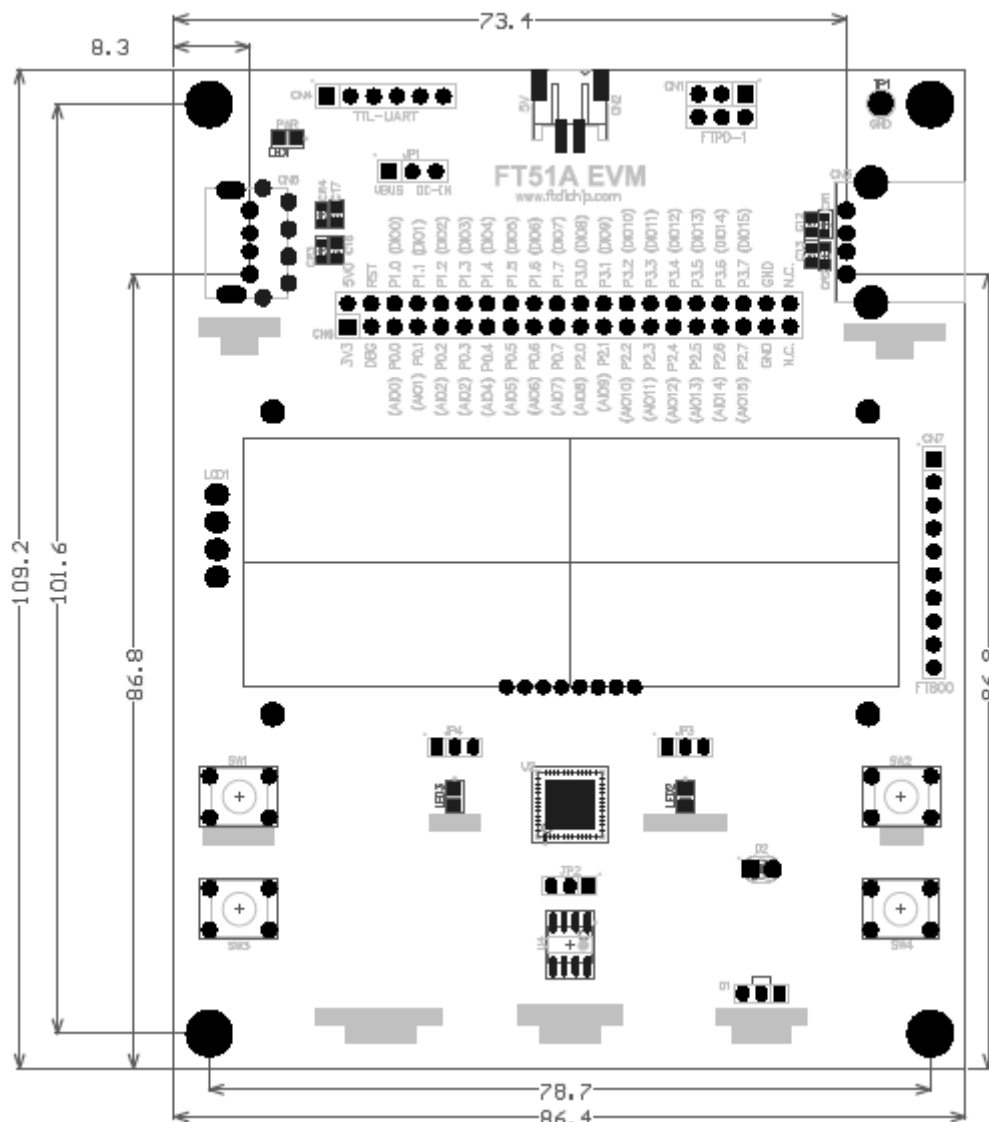
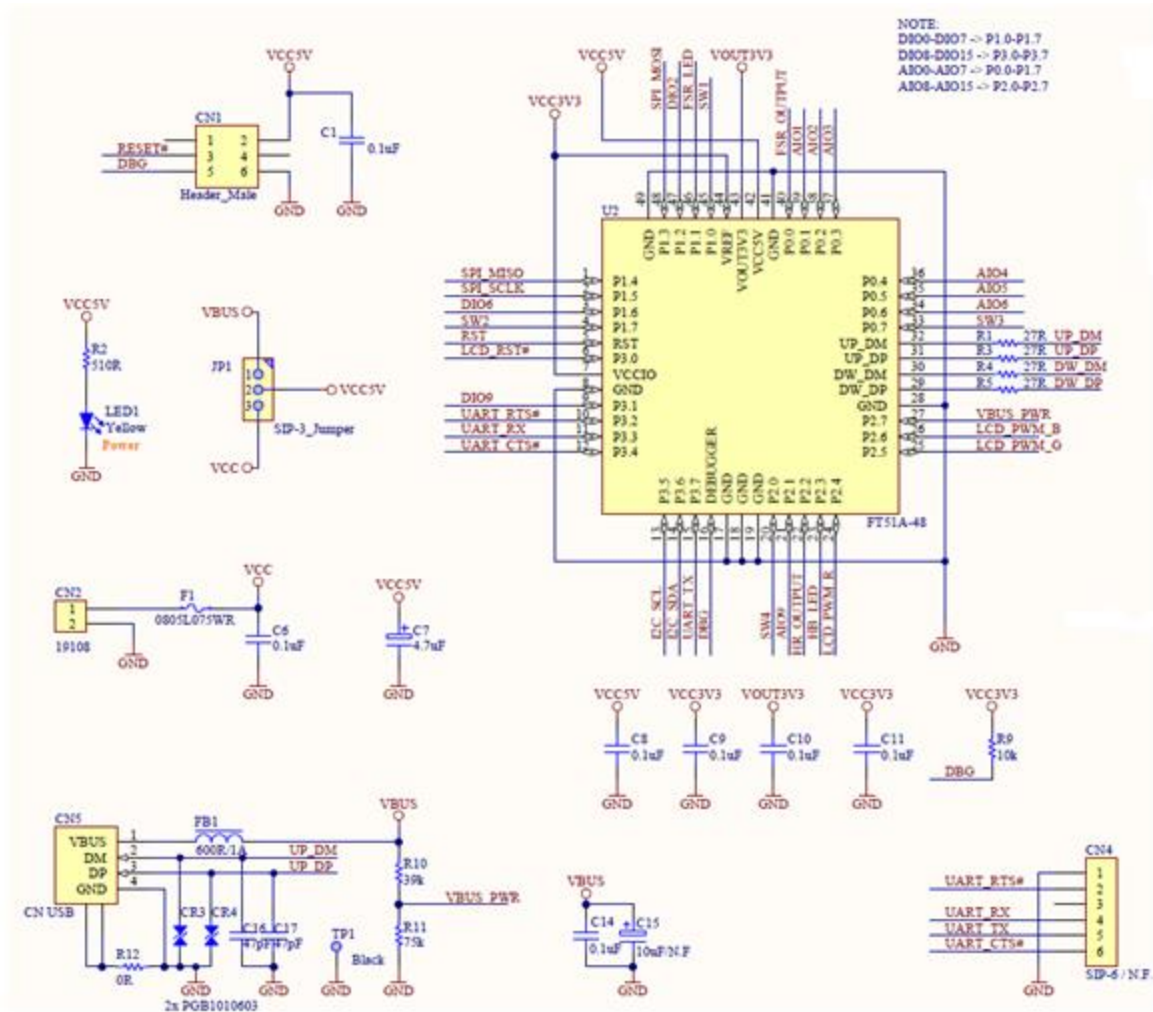

Figure 8.1 – FT51A-EVM Module Dimensions

All dimensions are given in millimetres. The height of the assembled module(including the rubber standing) is 15mm.

The FT51A-EVM module exclusively uses lead free components, and is fully compliant with European Union directive 2002/95/EC.

9 UMFT51AA Module Circuit Schematic



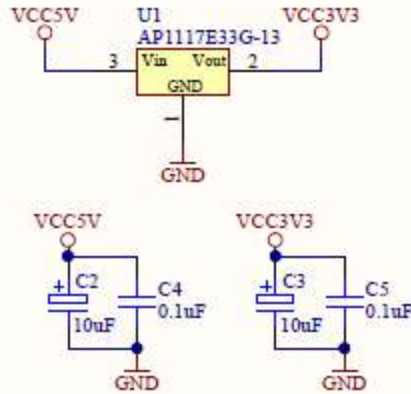

VBUS PWR	VBUS PWR
UART TX	UART TX
UART RTS#	UART RTS#
UART RX	UART RX
UART CTS#	UART CTS#

FSR OUTPUT	FSR OUTPUT
HR OUTPUT	HR OUTPUT
SPI SCLK	SPI SCLK
SPI MISO	SPI MISO
SPI MOSI	SPI MOSI
SPI CS#	SPI CS#
LCD_RST#	LCD_RST#
I2C_SCL	I2C_SCL
I2C_SDA	I2C_SDA
LCD_PWM_R	LCD_PWM_R
LCD_PWM_G	LCD_PWM_G
LCD_PWM_B	LCD_PWM_B
SW1	SW1
SW2	SW2
FSR_LED	FSR_LED
HB_LED	HB_LED

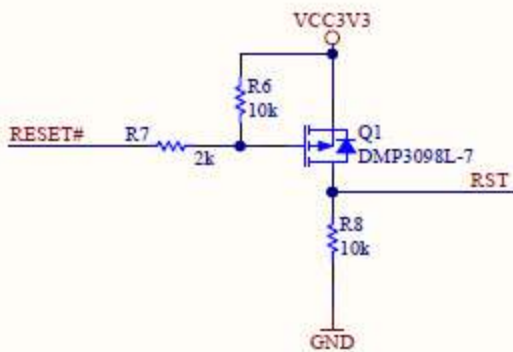

RST	RST
DIO2	DIO2
DIO6	DIO6
DIO9	DIO9
AIO1	AIO1
AIO2	AIO2
AIO3	AIO3
AIO4	AIO4
AIO5	AIO5
AIO6	AIO6
SW3	SW3
SW4	SW4
AIO9	AIO9
DBG	DBG

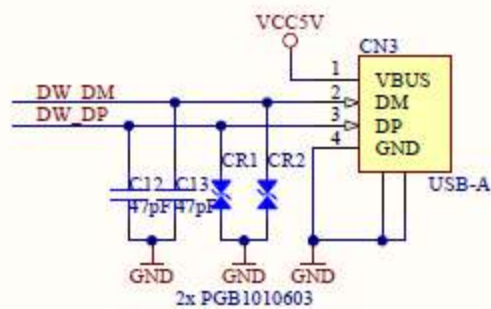

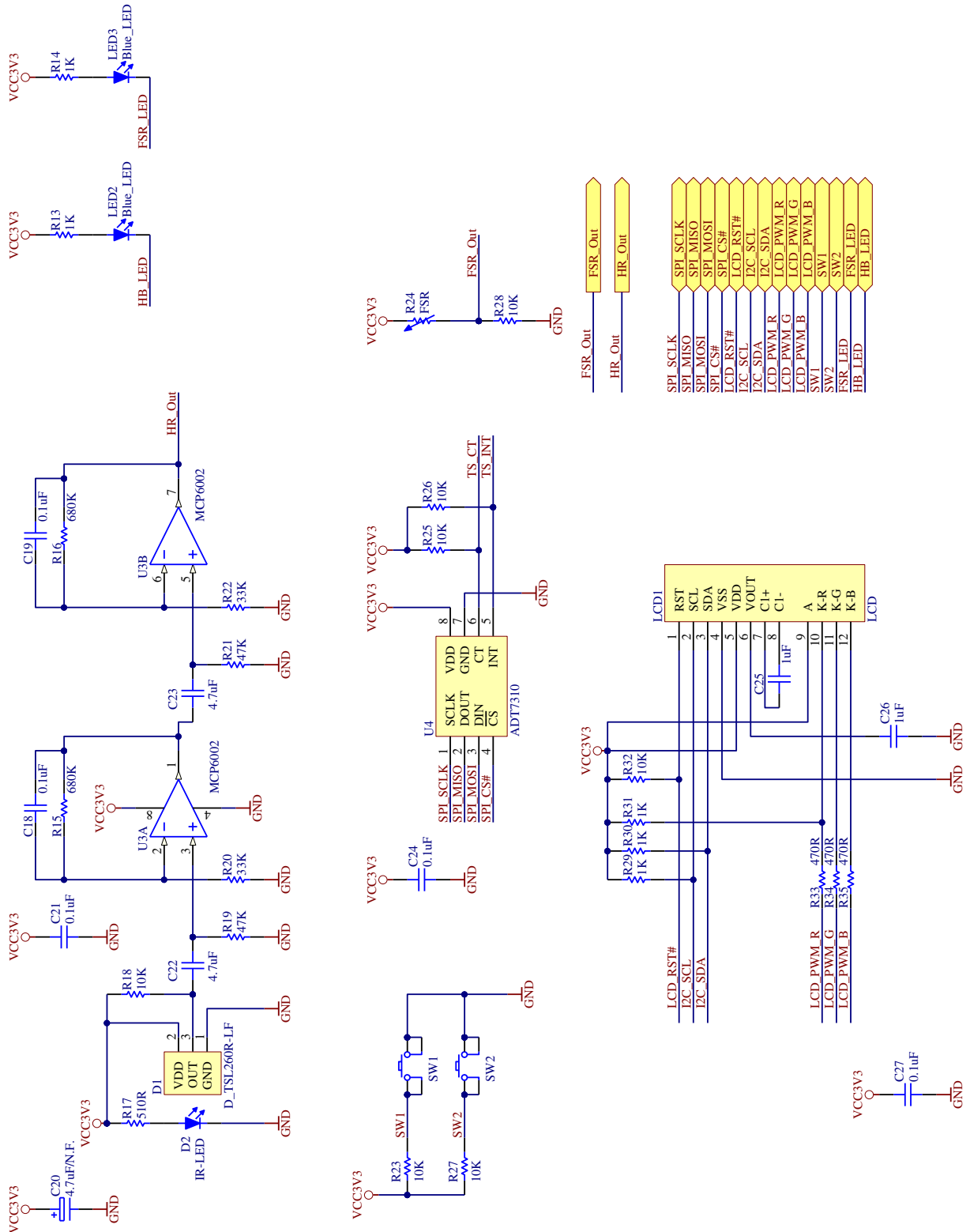

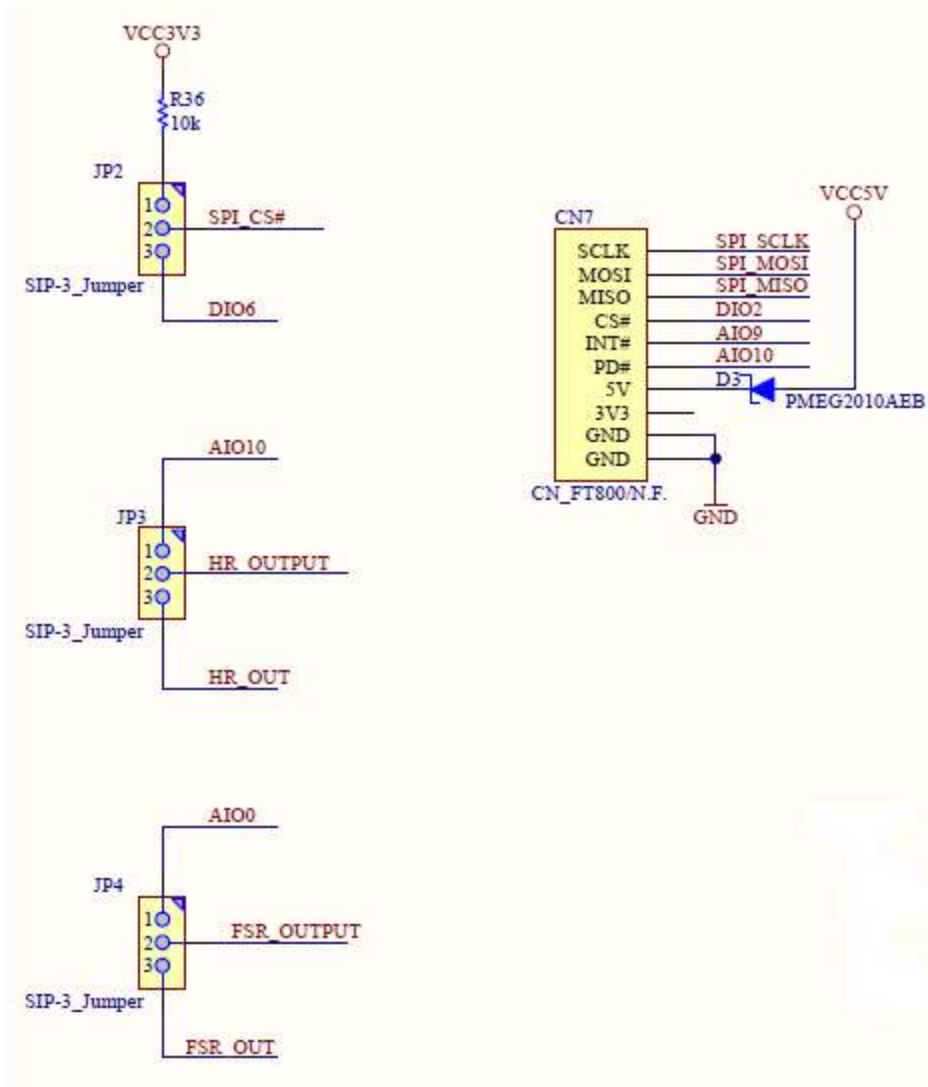

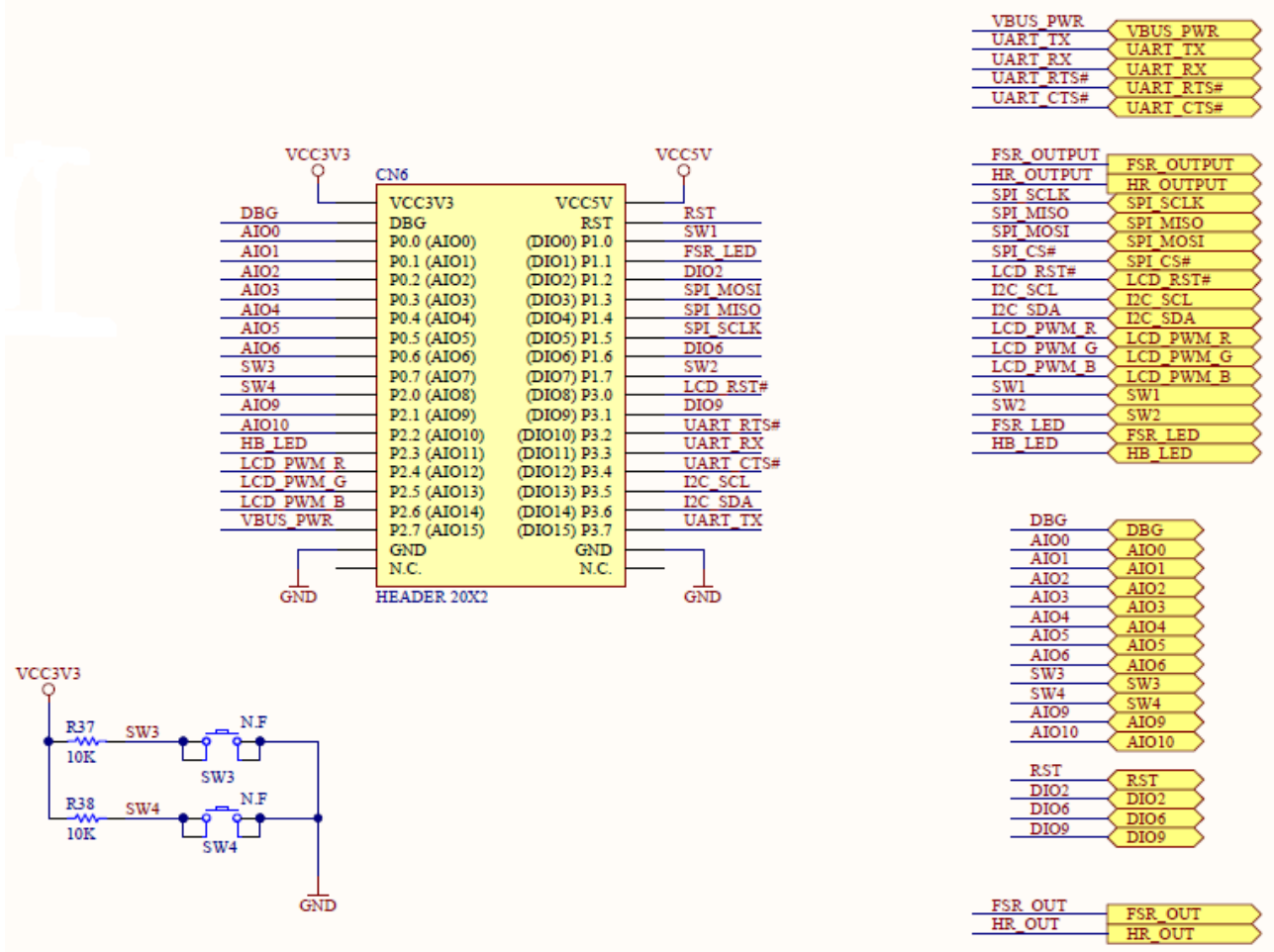

Figure 9.1 – Module Circuit Schematic

10 Contact Information

Head Office – Glasgow, UK

Unit 1, 2 Seaward Place, Centurion Business Park
Glasgow G41 1HH
United Kingdom
Tel: +44 (0) 141 429 2777
Fax: +44 (0) 141 429 2758

E-mail (Sales) sales1@ftdichip.com
E-mail (Support) support1@ftdichip.com
E-mail (General Enquiries) admin1@ftdichip.com

Branch Office – Tigard, Oregon, USA

7130 SW Fir Loop
Tigard, OR 97223
USA
Tel: +1 (503) 547 0988
Fax: +1 (503) 547 0987

E-Mail (Sales) us.sales@ftdichip.com
E-Mail (Support) us.support@ftdichip.com
E-Mail (General Enquiries) us.admin@ftdichip.com

Branch Office – Taipei, Taiwan

2F, No. 516, Sec. 1, NeiHu Road
Taipei 114
Taiwan, R.O.C.
Tel: +886 (0) 2 8797 1330
Fax: +886 (0) 2 8751 9737

E-mail (Sales) tw.sales1@ftdichip.com
E-mail (Support) tw.support1@ftdichip.com
E-mail (General Enquiries) tw.admin1@ftdichip.com

Branch Office – Shanghai, China

Room 1103, No. 666 West Huaihai Road,
Shanghai, 200052
China
Tel: +86 (0)21 6235 1596
Fax: +86 (0)21 6235 1595

E-mail (Sales) cn.sales@ftdichip.com
E-mail (Support) cn.support@ftdichip.com
E-mail (General Enquiries) cn.admin@ftdichip.com

Web Site

<http://ftdichip.com>

Distributor and Sales Representatives

Please visit the Sales Network page of the [FTDI Web site](#) for the contact details of our distributor(s) and sales representative(s) in your country.

System and equipment manufacturers and designers are responsible to ensure that their systems, and any Future Technology Devices International Ltd (FTDI) devices incorporated in their systems, meet all applicable safety, regulatory and system-level performance requirements. All application-related information in this document (including application descriptions, suggested FTDI devices and other materials) is provided for reference only. While FTDI has taken care to assure it is accurate, this information is subject to customer confirmation, and FTDI disclaims all liability for system designs and for any applications assistance provided by FTDI. Use of FTDI devices in life support and/or safety applications is entirely at the user's risk, and the user agrees to defend, indemnify and hold harmless FTDI from any and all damages, claims, suits or expense resulting from such use. This document is subject to change without notice. No freedom to use patents or other intellectual property rights is implied by the publication of this document. Neither the whole nor any part of the information contained in, or the product described in this document, may be adapted or reproduced in any material or electronic form without the prior written consent of the copyright holder. Future Technology Devices International Ltd, Unit 1, 2 Seaward Place, Centurion Business Park, Glasgow G41 1HH, United Kingdom. Scotland Registered Company Number: SC136640

Appendix A – References

Document References

[DS_FT51A](#) – FT51A datasheet

[DS_FTPD-1](#) – FT51A programmer module

[AN_289](#) – FT51A Programming Guide

Acronyms and Abbreviations

Terms	Description
DFU	Device Firmware Update
EVE	Embedded Video Engine
I ² C	Inter integrated Circuit
LCD	Liquid Crystal Display
LED	Light Emitting Diode
MCU	Micro Controller Unit
MTP	Multiple Time Programmable
USB	Universal Serial Bus

Appendix B – List of Figures and Tables

List of Figures

Figure 4.1 – Module Pin Out	5
Figure 6.1 – FT51A-EVM Module Dimensions.....	14
Figure 7.1 – Module Circuit Schematic	19

List of Tables

Table 4.1 – Debugger Port Pin Out Description.....	6
Table 4.2 – Power Port Pin Out Description	6
Table 4.3 – Downstream USB Port Pin Out Description.....	6
Table 4.4 – UART Port Pin Out Description	6
Table 4.5 – Upstream USB Port Pin Out Description	7
Table 4.6 – Module IO Pin Out Description	8
Table 4.7 – EVE/SPI Pin Out Description	9
Table 4.8 – I/O Signal Options.....	10
Table 5.1 – Jumper JP1 Modes.....	11
Table 5.2 – Jumper JP2 Modes.....	11
Table 5.3 – Jumper JP3 Modes.....	11
Table 5.4 – Jumper JP4 Modes.....	11

Appendix C – Revision History

Document Title: FT51A-EVM Development Module Datasheet
Document Reference No.: FT_001140
Clearance No.: FTDI# 478
Product Page: <http://www.ftdichip.com>
Document Feedback: [Send Feedback](#)

Revision	Changes	Date
Version 1.0	Initial Release	2015-11-18