

PRODUCT NO.	NOTE
72325-001	5.0V
72325-001LF	5.0V
72325-101	3.3V
72325-101LF	3.3V

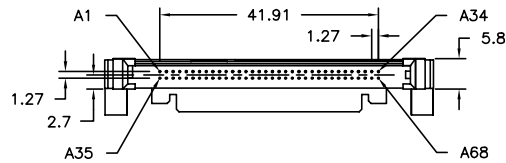
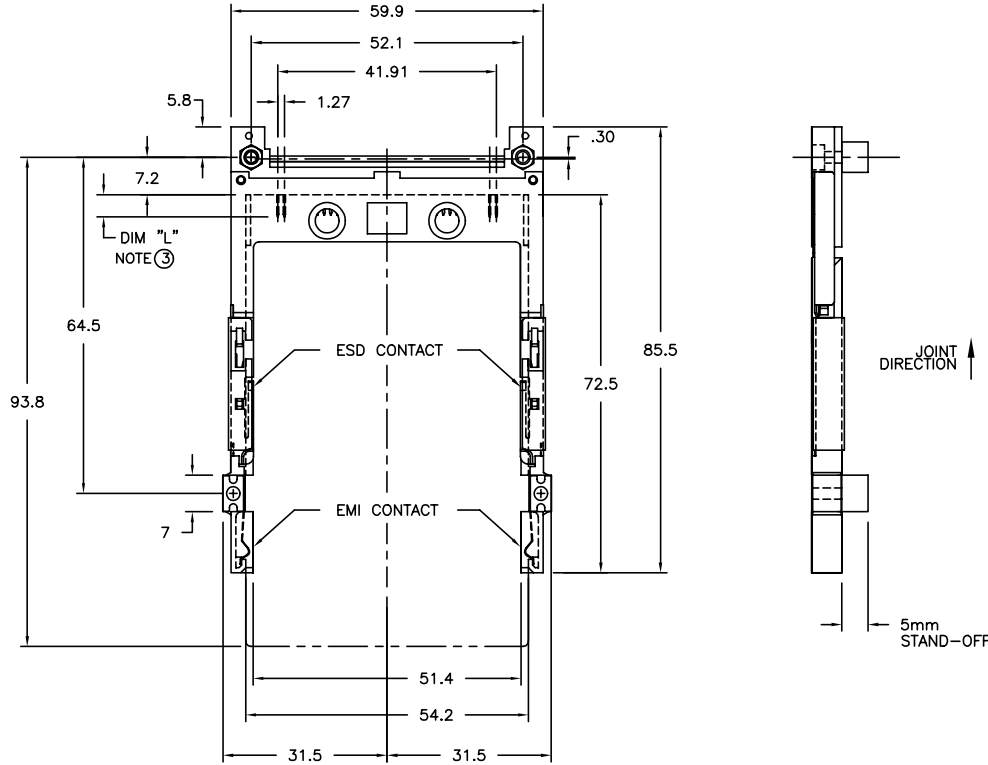

NOTES:

- HEADER ASSY**  
 PLASTIC: HOUSING - HIGH TEMPERATURE THERMOPLASTIC UL94V-0 BLACK - ABOVE PCB  
 PIN: PHOSPHOR BRONZE  
**GUIDE MECHANISM ASSY**  
 PLASTIC: GUIDE - HIGH TEMPERATURE THERMOPLASTIC UL94V-0 BLACK  
 COVER PLATE: STAINLESS STEEL  
 EMI CONTACT: PHOSPHOR BRONZE
- FINISH - PIN**  
 UNDER PLATING: 0.5um Ni  
 CONTACT AREA: 0.076 μm MIN. GOLD  
 SOLDER TAIL(TIN LEAD OPTION): 2.5um Sn-Pb  
 SOLDER TAIL(LEAD FREE OPTION): 2.5um PURE TIN
- DIM "L"**

4.25±.1	3.5±.1	5.0±.1
OTHERS	36,67	1,17,34,35,51,68
- RECOMMENDED HOLD DOWN - 2mm SCREWS**  
 95121 AND 2mm NUTS 92869.  
 SEE FOR CHARTED INFORMATION.  
 RECOMMENDED SCREW TORQUE: 1.0 TO 1.5 MAX in-lbs. (1.2-1.7 cm-kgs).
- SEE TA-1052 FOR PCB LAYOUT.
- MATING CONNECTOR: 91931-31169. MUST BE PURCHASED SEPARATELY.**
- IF LEAD FREE P.N.THE HOUSING WILL WITHSTAND EXPOSURE TO 260°C PEAK TEMPERATURE FOR 10 SECONDS IN A WAVE SOLDER APPLICATION WITH A 1.00MM MINIMUM THICK CIRCUIT BOARD.
- IF LEAD FREE P/N.THE PRODUCT MEETS EUROPEAN UNION DIRECTIVES AND OTHER COUNTRY REGULATIONS AS DESCRIBED IN GS-22-008
- LEAD FREE P/N PACKAGING MEETS GS-14-920 SPECIFICATION
- PRODUCT SPEC:110-263

mat'l. code	surface ISO1302 ✓	tolerance ISO1101 ISO406	projection MM	product family MCS
l trechn nodr	date	tolerances unless otherwise specified	scale 1:1	title
F V05-0302	WB 04/21/05	0.X±0.3		EJECTOR HEADER ASSEMBLY
G N05-0116	WB 04/27/05	0.XX±0.13		68 POS. SMT TYPE 123
H BX-N-011412	ZK 04/02/12	0.XXX±0.051		
dr	R.GRAPE	8/16/96		dwg no
enr	D.BRANN	8/16/96		sheet 1 of 5
chr	D.BRANN	8/16/96		size
appd	D.BRANN	8/16/96		A4
sheet index	revision	H H H H H		type Product Customer Drawing
	sheet	1 2 3 4 5		

PRODUCT NO.	NOTE
72325-002	5.0V
72325-002LF	5.0V
72325-102	3.3V
72325-102LF	3.3V

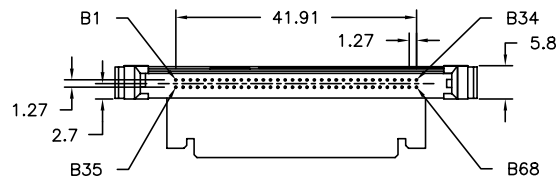
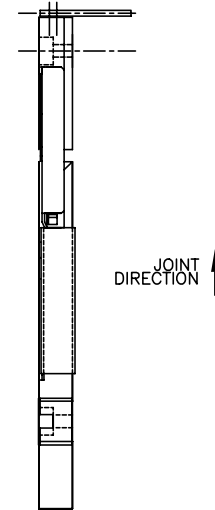
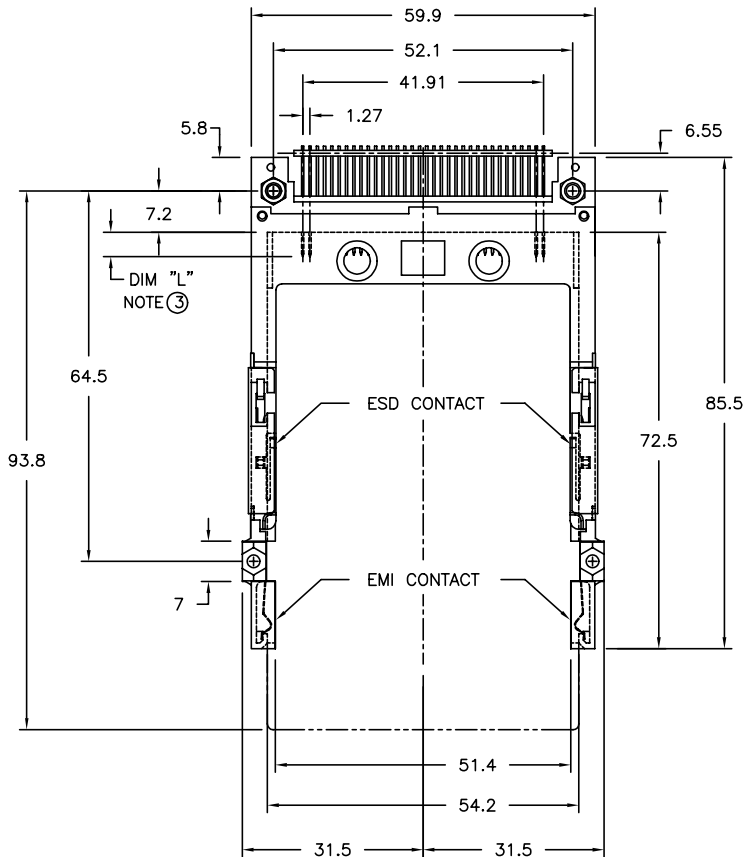

mat'l. code	surface ISO1302 ✓	tolerance ISO1101 ISO406	projection ASME Y14.5	product family MCS
ltr ecn n°dr	date		tolerances unless otherwise specified	title
H	angle	0.X±0.3 0.XX±0.13 0.XXX±0.051	MM ← →	EJECTOR HEADER ASSEMBLY 68 POS. SMT TYPE 123
	0°±2'	scale 1:1		
	dr	R.GRAPE	8/16/96	dwg no
	enr	D.BRANN	8/16/96	sheet 2 of 5
	chr	D.BRANN	8/16/96	72325
	app	D.BRANN	8/16/96	A4
sheet	revision			type Product Customer Drawing
index	sheet			

PRODUCT NO.	NOTE
72325-003	5.0V
72325-103	3.3V
72325-003LF	5.0V
72325-103LF	3.3V

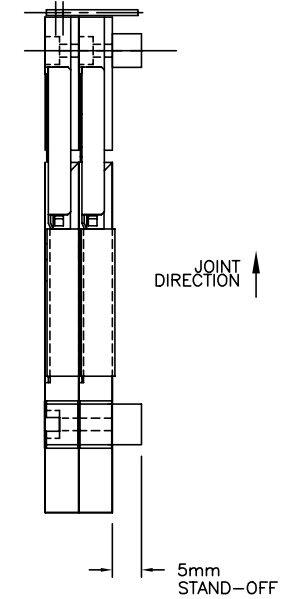
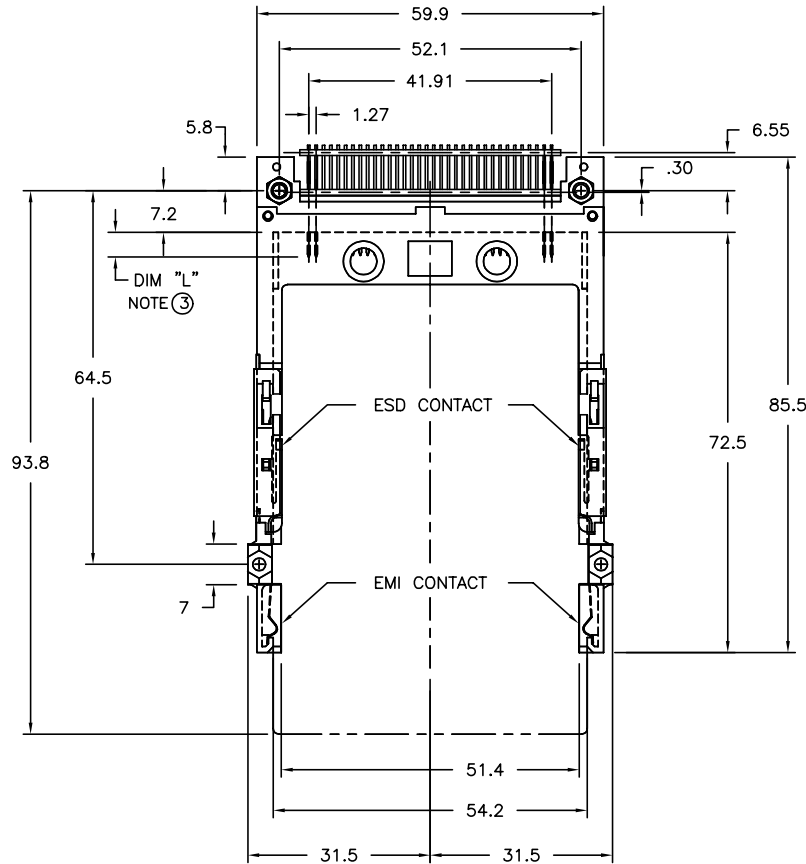

NOTE:  
TA-1052, PAGE 1, FOR PCB LAYOUT.

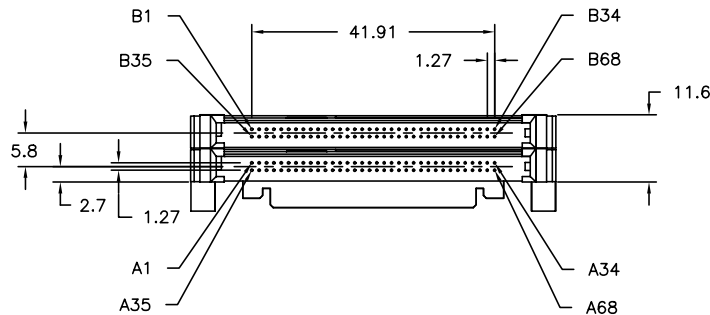

mat'l. code	surface ISO1302 ✓	tolerance ISO1101 ISO406	projection MM	product family MCS
ltr ecn nodr date	tolerances unless otherwise specified		scale 1:1	title EJECTOR HEADER ASSEMBLY 68 POS. SMT TYPE 123
H	angle 0°±2'	0.X±0.3 0.XX±0.13 0.XXX±0.051	MM	dwg no 72325
	dr R.GRAPE	8/16/96		sheet 3 of 5
	enr D.BRANN	8/16/96		size A4
	chr D.BRANN	8/16/96		type Product Customer Drawing
	appd D.BRANN	8/16/96		
sheet index	revision sheet			

PRODUCT NO.	NOTE
72325-004	5.0V
72325-004LF	5.0V
72325-104	3.3V
72325-104LF	3.3V

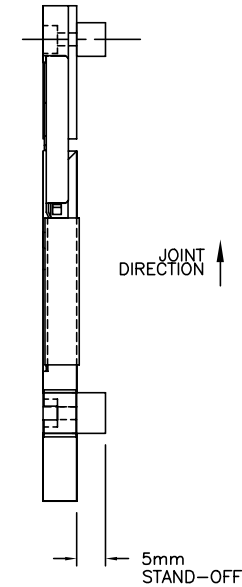
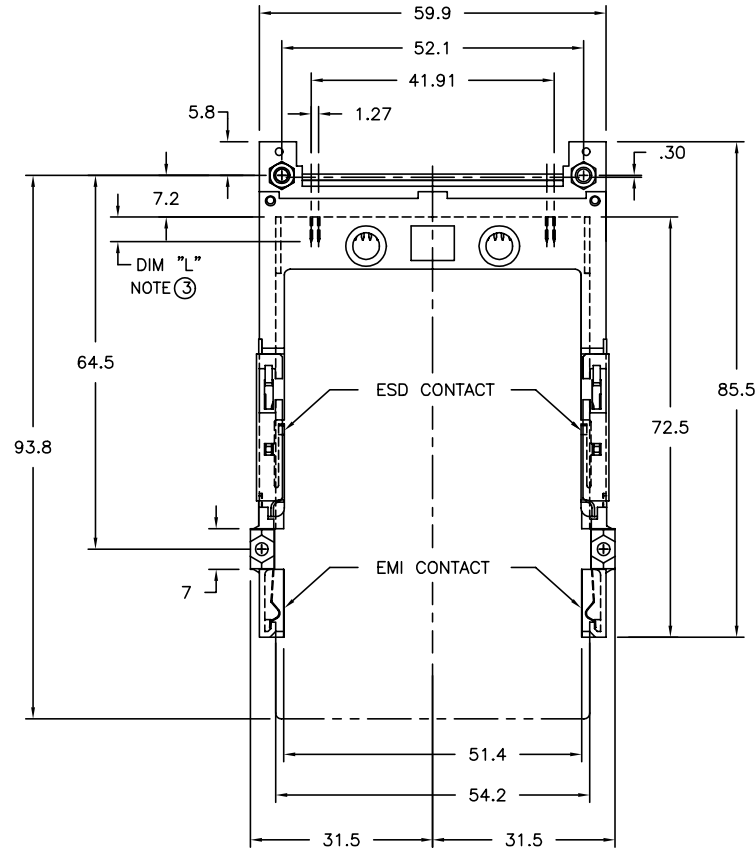

NOTE:

TA-1052, PAGE 3, FOR PCB LAYOUT.

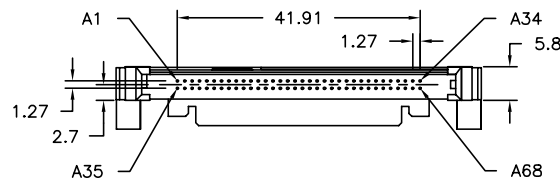

mat'l. code	surface ISO1302	tolerance ISO1101 ISO406	projection MM	product family MCS
l t r e c n n o d r	date	tolerances unless otherwise specified	scale 1:1	title EJECTOR HEADER ASSEMBLY 68 POS. SMT TYPE 123
H		angle 0°±2'		dwg no 72325
		dr R.GRAPE	8/16/96	sheet 4 of 5
		enr D.BRANN	8/16/96	size A4
		chr D.BRANN	8/16/96	type Product Customer Drawing
		appd D.BRANN	8/16/96	
sheet index	revision sheet			

PRODUCT NO.	NOTE
72325-005	5.0V
72325-005LF	5.0V
72325-105	3.3V
72325-105LF	3.3V

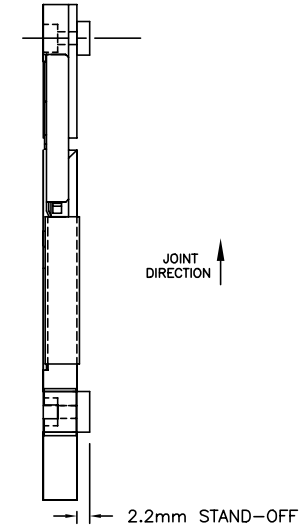
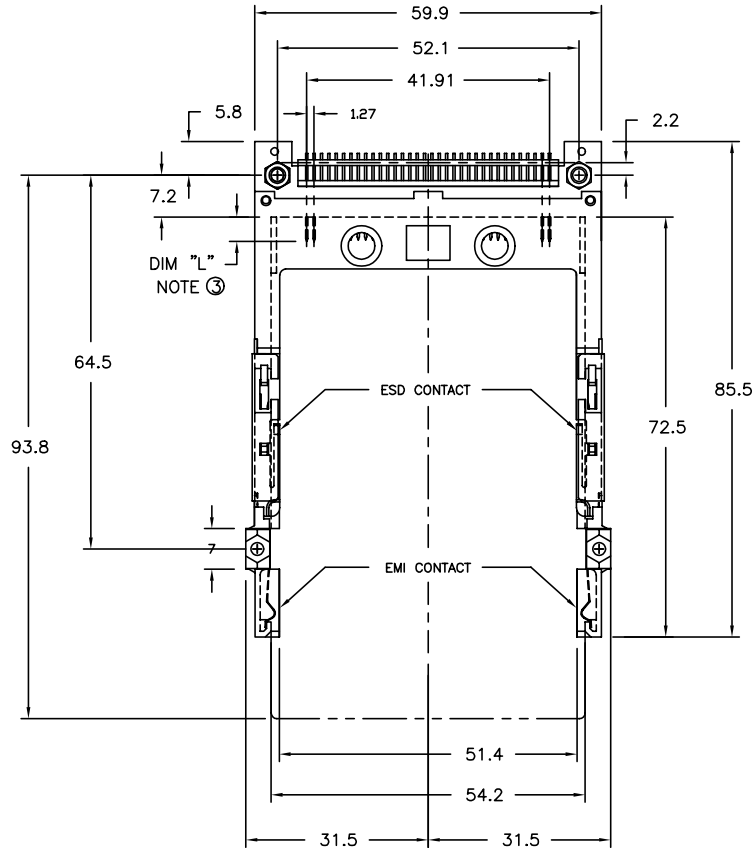

NOTE:  
TA-1052, PAGE 3, FOR PCB LAYOUT.

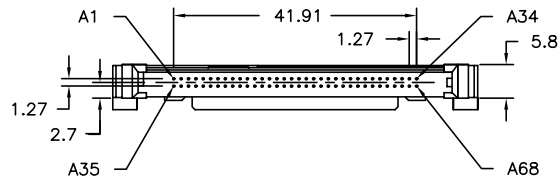

mat'l. code	surface ISO1302	tolerance ISO1101 ISO406	projection MM	product family MCS
l tr ecn nodr	tolerances unless otherwise specified		scale 1:1	title EJECTOR HEADER ASSEMBLY 68 POS. SMT TYPE 123
H	angle	0.X±0.3	MM	dwg no 72325
	0°±2'	0.XX±0.13	scale 1:1	sheet 5 of 5
		0.XXX±0.051		size A4
dr	R.GRAPE	8/16/96	FCI	type Product Customer Drawing
engr	D.BRANN	8/16/96		
chr	D.BRANN	8/16/96		
appd	D.BRANN	8/16/96		
sheet index	revision sheet			