

PCIe EXPANSION CARD APPLICATION SHOWN USING 1 DEGREE GUIDE HOUSING ASSEMBLY

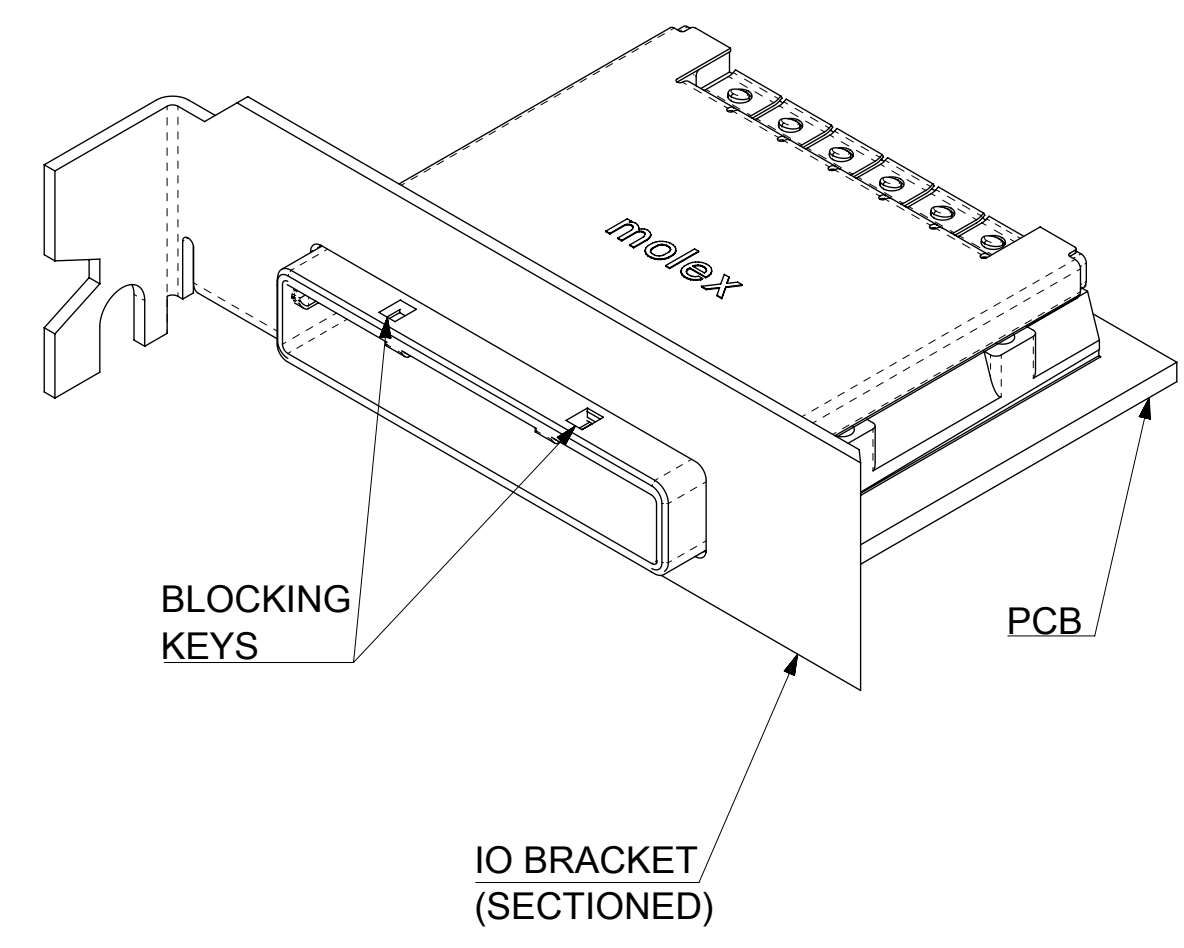

- NOTES:
- REF. PCI EXPRESS CARD ELECTROMECHANICAL SPECIFICATION, REV 1.0a FOR IO BRACKET WINDOW LOCATION.
 - PCB AND IO BRACKET SHOWN FOR REFERENCE ONLY.
 - REFER TO SHEET 2 FOR ATCA GUIDE HOUSING ASSY.
 - GUIDE HOUSING MOUNTING THREAD= M2 X 0.4, SEE SHEET 3 FOR SCREW LENGTH + TORQUE SPEC.
 - PCB NOTCH IS SHOWN FOR PCI COMPLIANT BOARD.
 - THIS PRODUCT MEETS THE RESTRICTION OF HAZARDOUS SUBSTANCES IN ELECTRICAL AND ELECTRONIC EQUIPMENT (RoHS) DIRECTIVE (2002/95/EC).
 - PLATE GROUND PAD WITH EMERSION SILVER OR GOLD.
 - MATES WITH MOLEX 8X CABLE SERIES 74546-080X.
 - GUIDE HOUSING PEGS FOR ALIGNMENT ONLY, DO NOT SOLDER.
 - MATERIAL: Ni PLATED ZINC DIECAST.

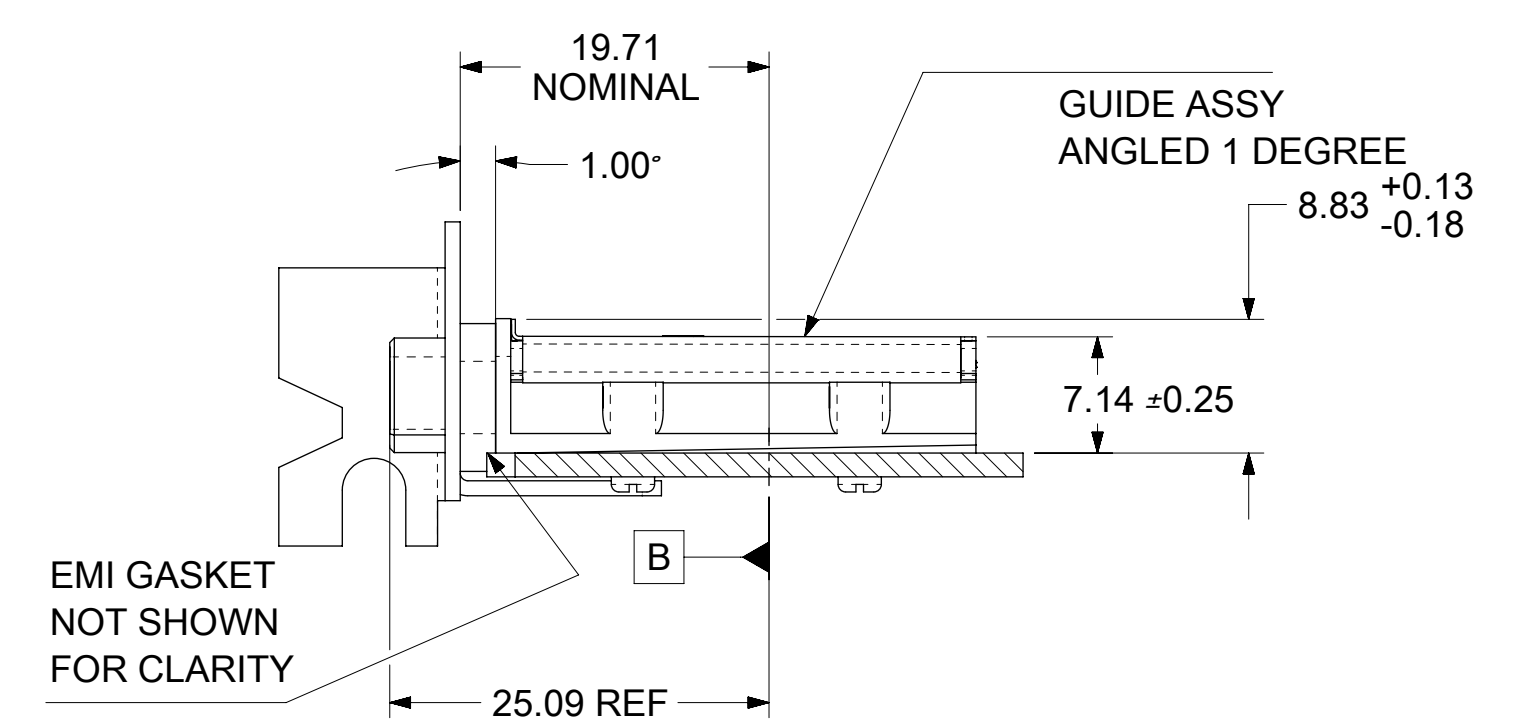

PCIe GUIDE HOUSING ASSEMBLY

iPass™ is a trademark of Molex

SYMBOLS		THIS DRAWING CONTAINS INFORMATION THAT IS PROPRIETARY TO MOLEX ELECTRONIC TECHNOLOGIES, LLC AND SHOULD NOT BE USED WITHOUT WRITTEN PERMISSION		CURRENT REV DESC: SEE REVISION TABLE		
▽ = 0	mm	SCALE	2:1	molex I-PASS X8 EMI GUIDE HOUSING ASSEMBLY W/ KEYS PRODUCT CUSTOMER DRAWING		
▽ = 0	GENERAL TOLERANCES (UNLESS SPECIFIED)					
▽ = 0	ANGULAR TOL ± 0.5°					
▽ = 0	4 PLACES ±					
▽ = 0	3 PLACES ±	EC NO: 610421 DRWN: NMUTHARAYAPP 2018/12/26 CHK'D: VK10 2019/01/15 APPR: RCHEN08 2019/01/15		DOCUMENT NUMBER		
▽ = 0	2 PLACES ± 0.05	INITIAL REVISION:		745400101		
▽ = 0	1 PLACE ± 0.1	DRWN: NMUTHARAYAPP 2018/12/26		PSD ASY K		
▽ = 0	0 PLACES ±	APPR: RCHEN08 2019/01/15		MATERIAL NUMBER		
▽ = 0	DRAFT WHERE APPLICABLE MUST REMAIN WITHIN DIMENSIONS	THIRD ANGLE PROJECTION	DRAWING	SERIES	CUSTOMER	SHEET NUMBER
▽ = 0			C-SIZE	74540	SEE P/N TABLE	1 OF 4

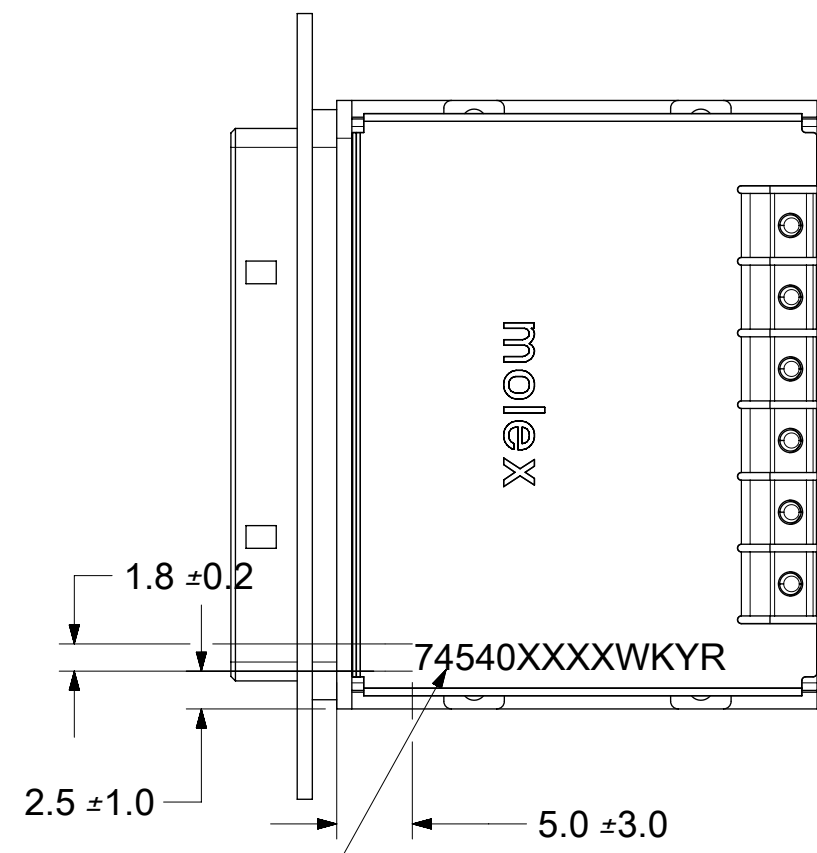

P/N AND WEEK/YEAR DATE CODE TO BE PRINTED ON THE TOP OF COMPLETED CAGE ASSEMBLY AS SHOWN. SEE TABLE BELOW FOR DATE CODE INFORMATION.

WEEK/YEAR DATE CODE TABLE	
WK	WEEK OF THE YEAR 01 THRU 52 (EXAMPLE: 01= FIRST WEEK OF YEAR 52= LAST WEEK OF YEAR)
YR	19, 20, 21,, ETC.. (EXAMPLE: YEAR 2019= 19)

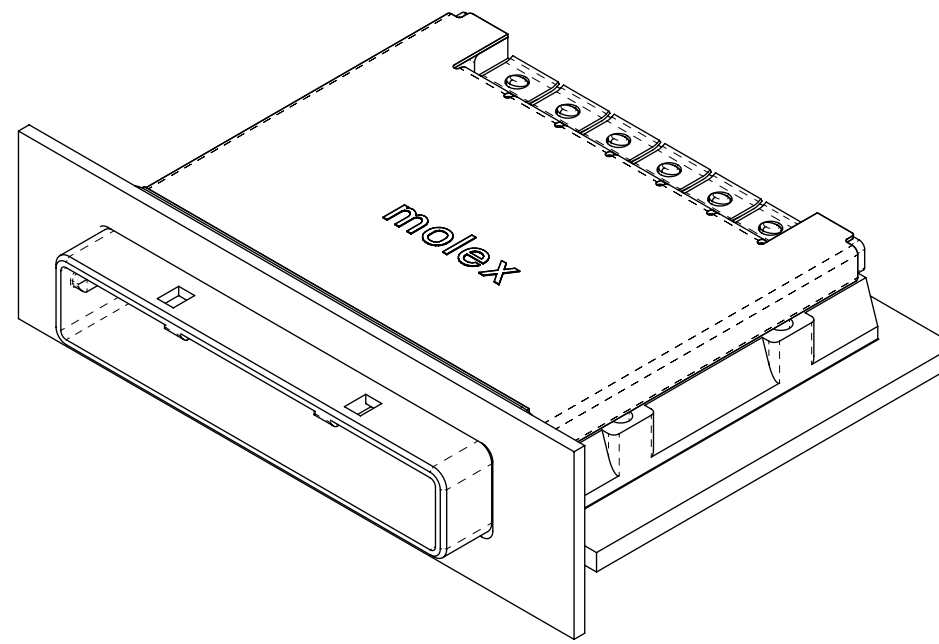

STANDARD APPLICATION SHOWN USING 0 DEG GUIDE HOUSING ASSEMBLY

GASKETS NOT SHOWN FOR CLARITY

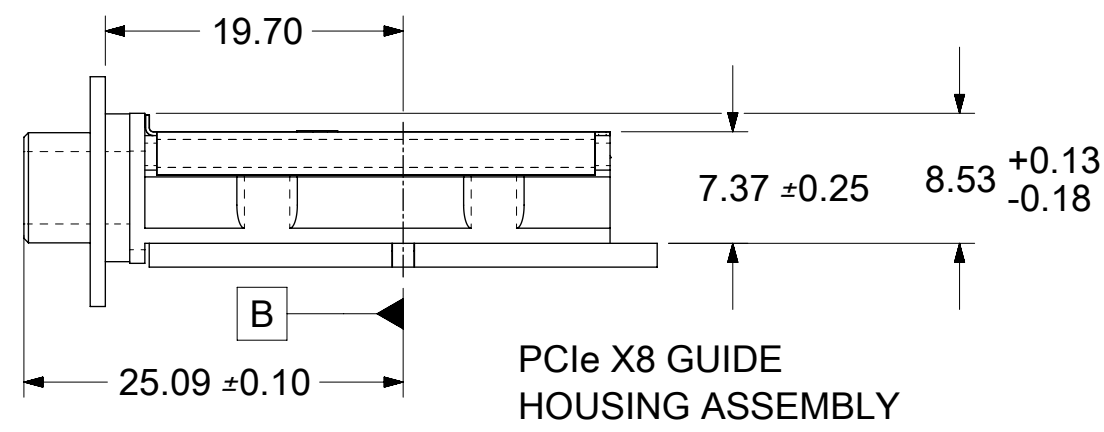
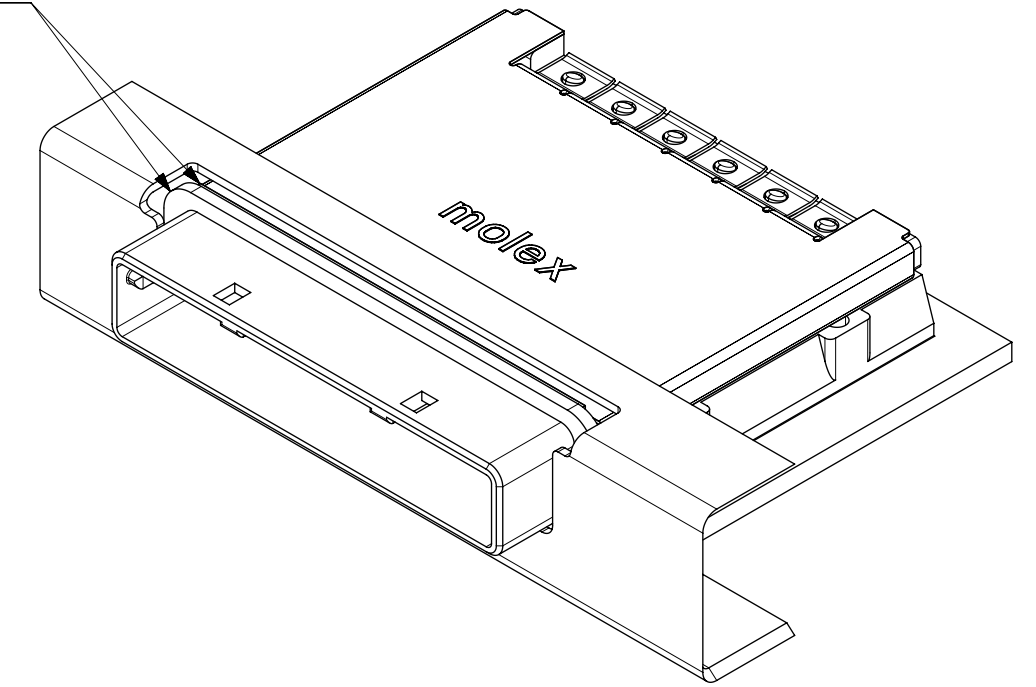

PCIe X8 GUIDE HOUSING ASSEMBLY

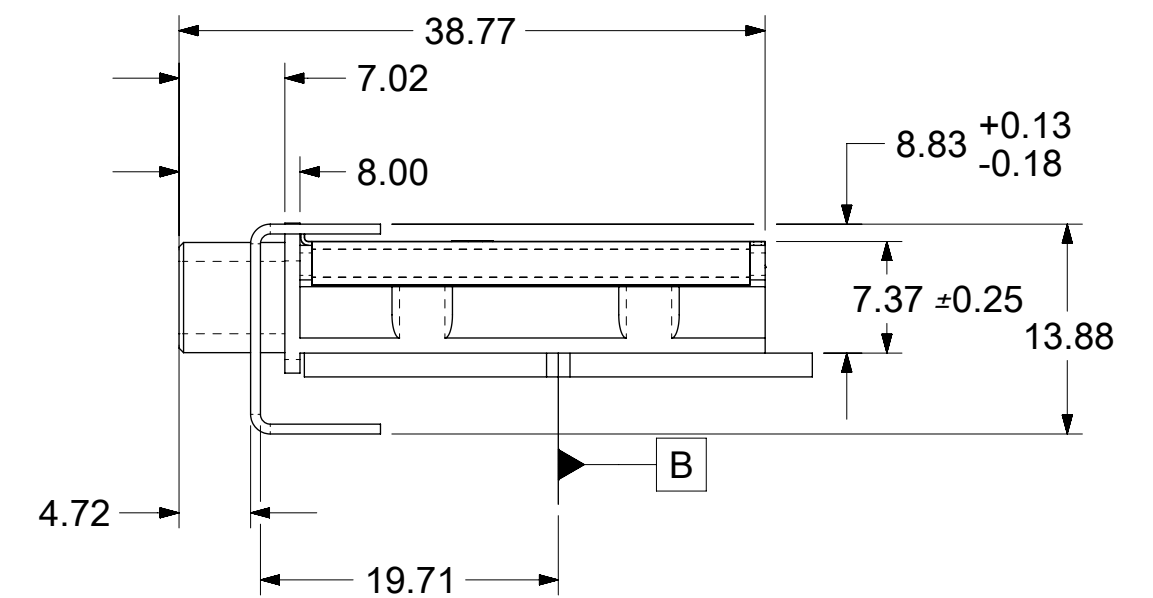
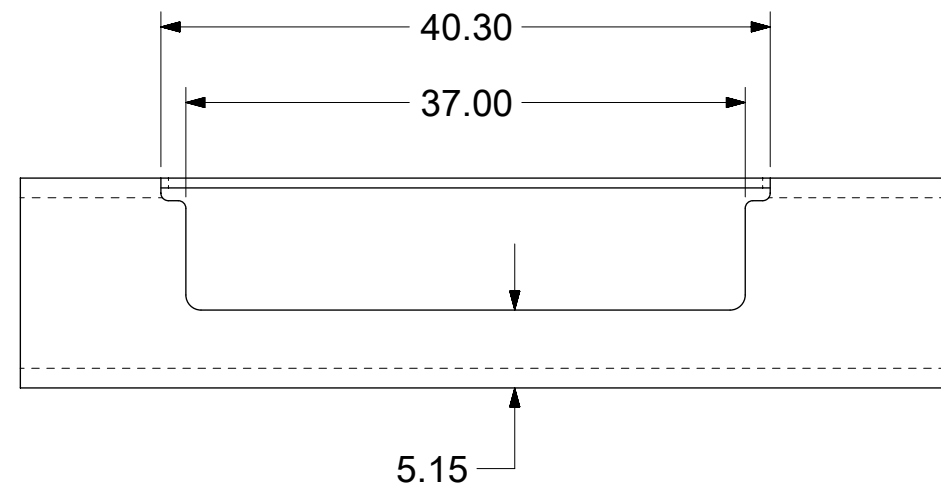

ADVANCED TCA APPLICATION USING 0 DEG GUIDE HOUSING ASSEMBLY

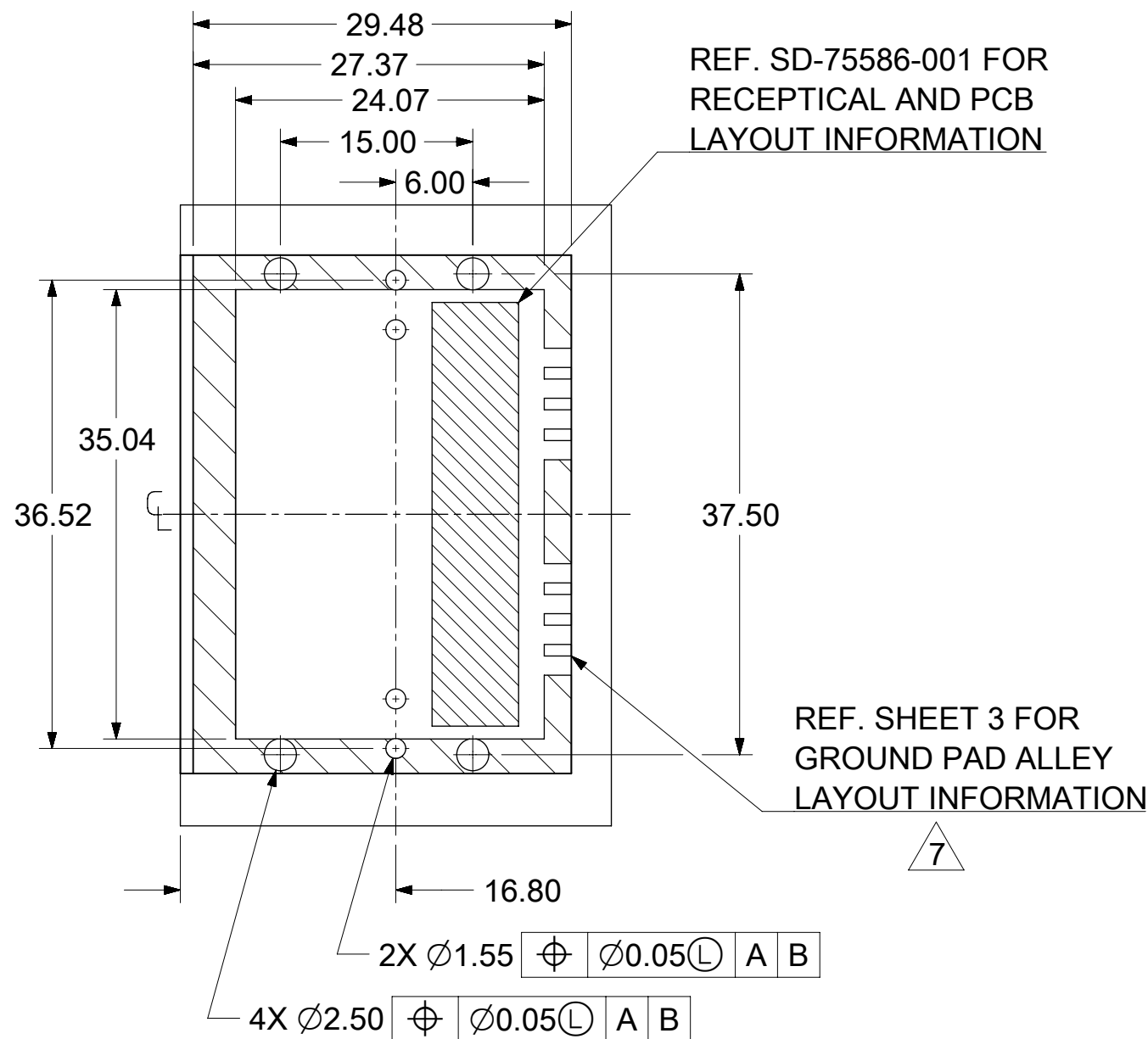

REF. SD-75586-001 FOR RECEPTICAL AND PCB LAYOUT INFORMATION

REF. SHEET 3 FOR GROUND PAD ALLEY LAYOUT INFORMATION



iPass™ is a trademark of Molex

SYMBOLS		THIS DRAWING CONTAINS INFORMATION THAT IS PROPRIETARY TO MOLEX ELECTRONIC TECHNOLOGIES, LLC AND SHOULD NOT BE USED WITHOUT WRITTEN PERMISSION	
DIMENSION UNITS	SCALE	CURRENT REV DESC: SEE REVISION TABLE	
$\nabla = 0$	mm	2:1	
$\nabla = 0$	GENERAL TOLERANCES (UNLESS SPECIFIED)		
$\nabla = 0$	ANGULAR TOL $\pm 0.5^\circ$		
$\nabla = 0$	4 PLACES	\pm	
$\nabla = 0$	3 PLACES	\pm	
$\nabla = 0$	2 PLACES	± 0.05	
$\nabla = 0$	1 PLACE	± 0.1	
$\nabla = 0$	0 PLACES	\pm	
$\nabla = 0$	DRAFT WHERE APPLICABLE MUST REMAIN WITHIN DIMENSIONS		
	THIRD ANGLE PROJECTION	DRAWING	SERIES
		C-SIZE	74540
		EC NO: 610421	
		DRWN: NMUTHARAYAPP	2018/12/26
		CHK'D: VK10	2019/01/15
		APPR: RCHEN08	2019/01/15
		INITIAL REVISION:	
		DRWN: NMUTHARAYAPP	2018/12/26
		APPR: RCHEN08	2019/01/15
DOCUMENT NUMBER		DOC TYPE	DOC PART
745400101		PSD	ASY
MATERIAL NUMBER		CUSTOMER	SHEET NUMBER
SEE P/N TABLE			2 OF 4

molex
I-PASS X8 EMI
GUIDE HOUSING ASSEMBLY W/ KEYS

PRODUCT CUSTOMER DRAWING

DOCUMENT NUMBER: 745400101, DOC TYPE: PSD, DOC PART: ASY, REVISION: K

MATERIAL NUMBER: SEE P/N TABLE, CUSTOMER: , SHEET NUMBER: 2 OF 4

MOLEX P/N	DESCRIPTION	GEN
745400101	8x EMI Guide Housing Assembly - PCIe / 1 Deg	Gen 1
745400201	8x EMI Guide Housing Assembly - ATCA / 0 Deg	Gen 1

PCB THICKNESS	SCREW LENGTH	TORQUE(IN LBS)
1.6	5MM	2.3
2.38	6MM	2.3
3.2	6MM	2.3
X	+4MM MAX	2.3

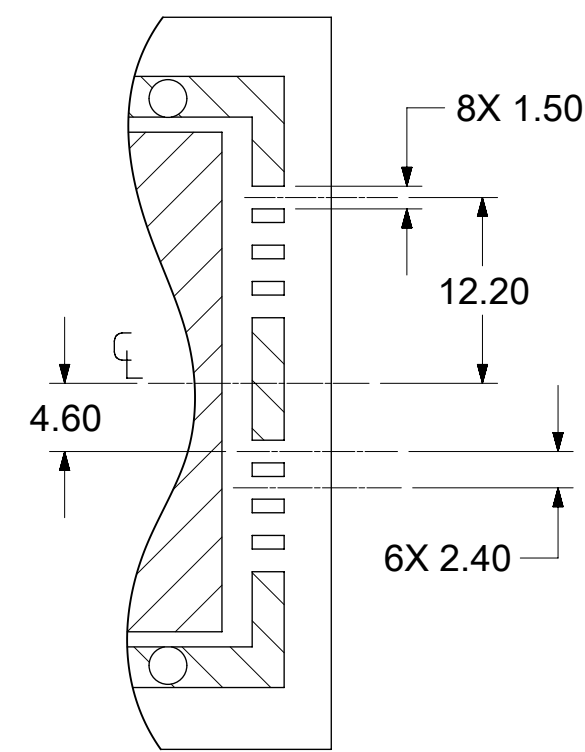

GROUND PAD ALLEY
LAYOUT INFORMATION



THIS DRAWING CONTAINS INFORMATION THAT IS PROPRIETARY TO MOLEX ELECTRONIC TECHNOLOGIES, LLC AND SHOULD NOT BE USED WITHOUT WRITTEN PERMISSION									
SYMBOLS	DIMENSION UNITS	SCALE	CURRENT REV DESC: SEE REVISION TABLE						
▽ = 0	mm	2:1	molex I-PASS X8 EMI GUIDE HOUSING ASSEMBLY W/ KEYS PRODUCT CUSTOMER DRAWING						
▽ = 0	GENERAL TOLERANCES (UNLESS SPECIFIED)								
▽ = 0	ANGULAR TOL ± 0.5°								
▽ = 0	4 PLACES ±								
▽ = 0	3 PLACES ±		EC NO: 610421 DRWN: NMUTHARAYAPP 2018/12/26 CHK'D: VK10 2019/01/15 APPR: RCHEN08 2019/01/15						
▽ = 0	2 PLACES ± 0.05		INITIAL REVISION: DRWN: NMUTHARAYAPP 2018/12/26 APPR: RCHEN08 2019/01/15						
▽ = 0	1 PLACE ± 0.1		DOCUMENT NUMBER		DOC TYPE	DOC PART	REVISION		
▽ = 0	0 PLACES ±		745400101		PSD	ASY	K		
▽ = 0	DRAFT WHERE APPLICABLE MUST REMAIN WITHIN DIMENSIONS		THIRD ANGLE PROJECTION	DRAWING	SERIES	MATERIAL NUMBER	CUSTOMER	SHEET NUMBER	
▽ = 0				C-SIZE	74540	SEE P/N TABLE		3 OF 4	

REVISION HISTORY

REV	DATE (YEAR/MONTH/DAY)	DESCRIPTION
H	2013/12/18	1. ADDED NOTES 10. MATERIAL: Ni PLATED ZINC DIECAST. [SHT 1] 2. CHANGED W/ NEW MOLEX FORMAT
J	2014/07/11	1. CHANGED 25.16 TO 25.09REF TO MEET PCI EXPRESS EXTERNAL CABLING SPECIFICATION @A9 [SHEET 1] 2. ADDED MM 3D NO. @F10 [SHEET 1] 3. THE MOLEX CHARACTER FIGURE UPDATE @F2 [SHEET 1], @F2 F5 [SHEET 2] 4. CHANGED 25.09 TO 25.09+/-0.1 @E9 [SHEET 2]
K	2019/01/15	1. REMASTERD FROM SD-74540-101 REV J TO 745400101 PSD ASY REV_K IN NX 2. SHEET 2: G11 :ADDED TOP VIEW AND PLACED INK MARK IN TOP VIEW

SYMBOLS										THIS DRAWING CONTAINS INFORMATION THAT IS PROPRIETARY TO MOLEX ELECTRONIC TECHNOLOGIES, LLC AND SHOULD NOT BE USED WITHOUT WRITTEN PERMISSION																								
DIMENSION UNITS					SCALE					CURRENT REV DESC: SEE REVISION TABLE																								
mm					1:1					EC NO: 610421 DRWN: NMUTHARAYAPP 2018/12/26 CHK'D: VK10 2019/01/15 APPR: RCHEN08 2019/01/15																								
GENERAL TOLERANCES (UNLESS SPECIFIED)																																		
ANGULAR TOL ± 0.5°										INITIAL REVISION: DRWN: NMUTHARAYAPP 2018/12/26 APPR: RCHEN08 2019/01/15																								
4 PLACES ±																																		
3 PLACES ±										DOCUMENT NUMBER 745400101																								
2 PLACES ± 0.05																																		
1 PLACE ± 0.1										DOC TYPE DOC PART REVISION PSD ASY K																								
0 PLACES ±																																		
DRAFT WHERE APPLICABLE MUST REMAIN WITHIN DIMENSIONS					THIRD ANGLE PROJECTION					DRAWING					SERIES					MATERIAL NUMBER					CUSTOMER					SHEET NUMBER				
										C-SIZE					74540					SEE P/N TABLE										4 OF 4				

molex

I-PASS X8 EMI
GUIDE HOUSING ASSEMBLY W/ KEYS

PRODUCT CUSTOMER DRAWING

MM : TM-74540-0206

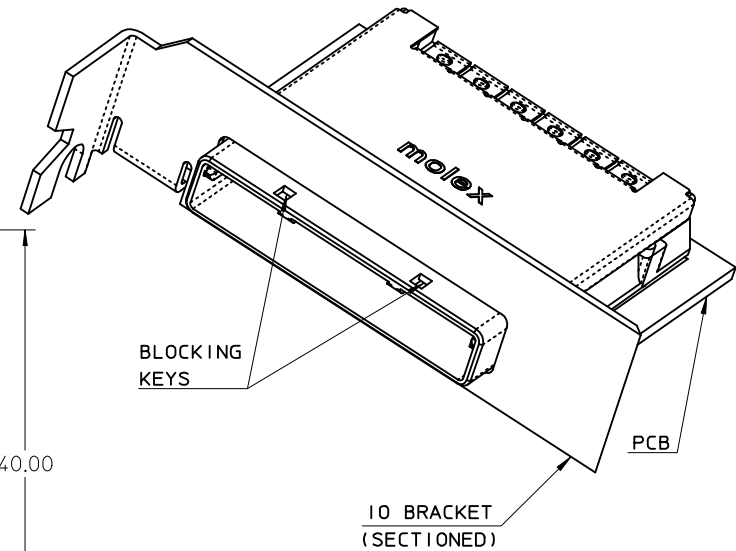
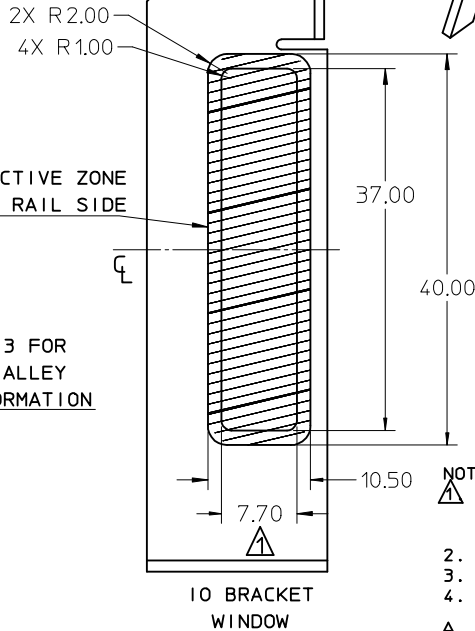
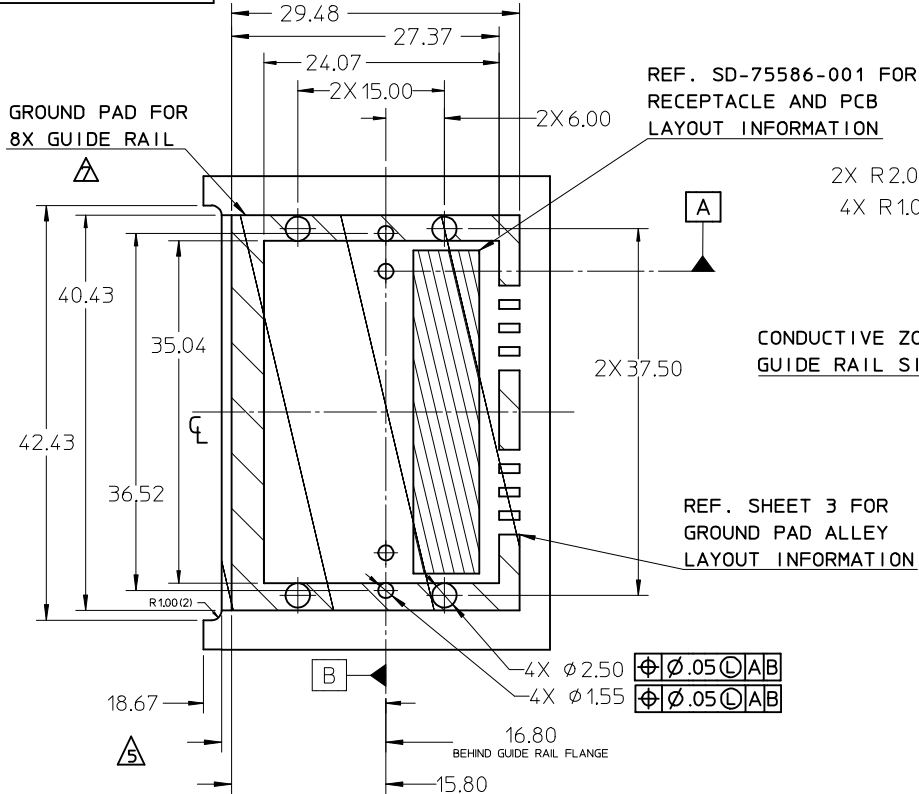

PCIe EXPANSION CARD APPLICATION SHOWN USING 1 DEGREE GUIDE HOUSING ASSEMBLY

- NOTES:
- REF. PCI EXPRESS CARD ELECTROMECHANICAL SPECIFICATION, REV 1.0a FOR 10 BRACKET WINDOW LOCATION.
 - PCB AND 10 BRACKET SHOWN FOR REFERENCE ONLY.
 - REFER TO SHEET 2 FOR ATCA GUIDE HOUSING ASSY.
 - GUIDE HOUSING MOUNTING THREAD= M2 X 0.4, SEE SHEET 3 FOR SCREW LENGTH + TORQUE SPEC.
 - PCB NOTCH IS SHOWN FOR PCI COMPLIANT BOARD.
 - THIS PRODUCT MEETS THE RESTRICTION OF HAZARDOUS SUBSTANCES IN ELECTRICAL AND ELECTRONIC EQUIPMENT (RoHS) DIRECTIVE (2002/95/EC).
 - PLATE GROUND PAD WITH EMERSION SILVER OR GOLD.
 - MATES WITH MOLEX 8X CABLE SERIES 74546-080X.
 - GUIDE HOUSING PEGS FOR ALIGNMENT ONLY, DO NOT SOLDER.
 - MATERIAL: NI PLATED ZINC DIECAST.

iPass™ is a trademark of Molex

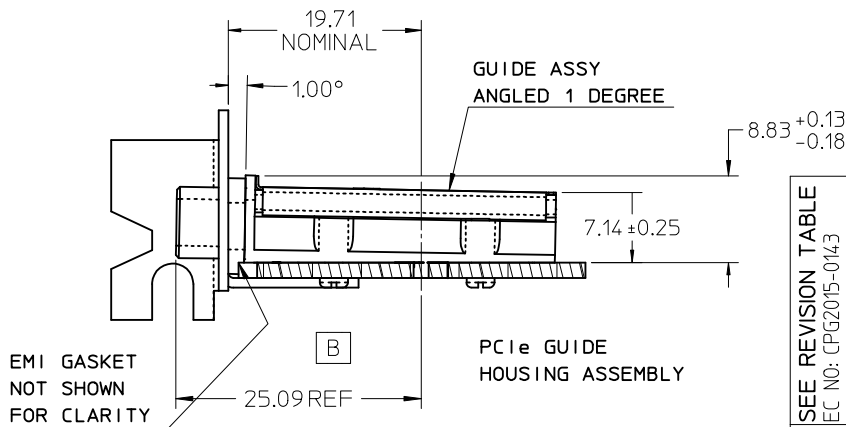

SEE REVISION TABLE EC NO: CPG2015-0143 DRAWN: WANG07 2014/07/11 CHKD: SYANG16 2014/07/14 APPR: RCHEN08 2014/07/28	QUALITY SYMBOLS	GENERAL TOLERANCES (UNLESS SPECIFIED)	DIMENSION STYLE	SCALE	DESIGN UNITS	THIRD ANGLE PROJECTION
	▽=0	mm INCH	MM ONLY	2:1	METRIC	THIRD ANGLE PROJECTION
	▽=0	4 PLACES ± --- ± ---	DRAWN BY DATE	TITLE		
	▽=0	3 PLACES ± --- ± ---	JERWIN 2006/05/25	I-PASS X8 EMI GUIDE HOUSING ASSEMBLY W/ KEYS		
	▽=0	2 PLACES ± 0.05 ± ---	CHECKED BY DATE	molex		

1 PLACE ± 0.10 ± ---	APPROVED BY DATE	MATERIAL NO.	DOCUMENT NO.	SHEET NO.
0 PLACE ± ±	DDOYE 2006/05/25	SEE P/N TABLE	SD-74540-101	1 OF 4

ANGULAR ± 1/2°
DRAFT WHERE APPLICABLE MUST REMAIN WITHIN DIMENSIONS

SIZE B
THIS DRAWING CONTAINS INFORMATION THAT IS PROPRIETARY TO MOLEX INCORPORATED AND SHOULD NOT BE USED WITHOUT WRITTEN PERMISSION

10 9 8 7 6 5 4 3 2 1

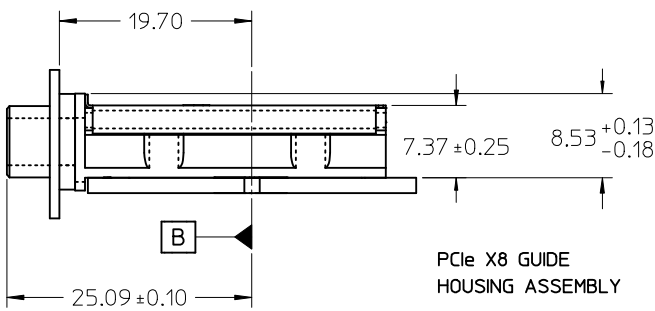

PCIe X8 GUIDE HOUSING ASSEMBLY

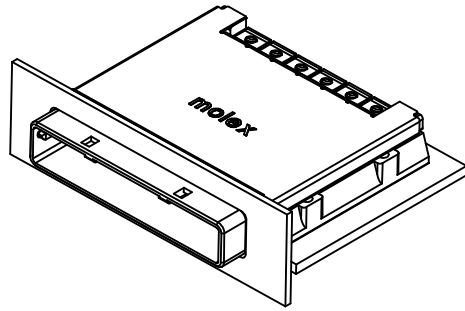

STANDARD APPLICATION SHOWN USING 0 DEG GUIDE HOUSING ASSEMBLY

GASKETS NOT SHOWN FOR CLARITY

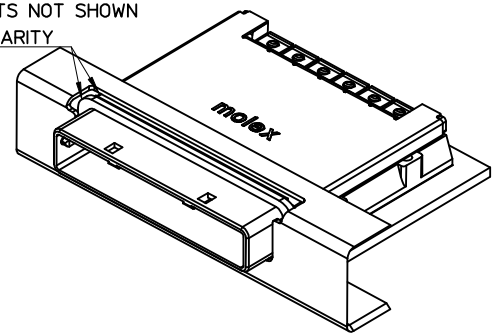

ADVANCED TCA APPLICATION USING 0 DEG GUIDE HOUSING ASSEMBLY

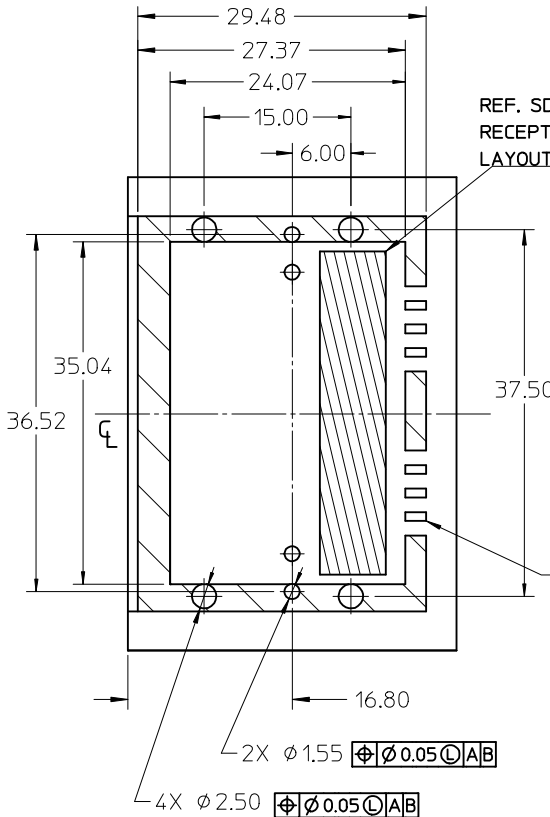

REF. SD-75586-001 FOR RECEPTAL AND PCB LAYOUT INFORMATION

REF. SHEET 3 FOR GROUND PAD ALLEY LAYOUT INFORMATION

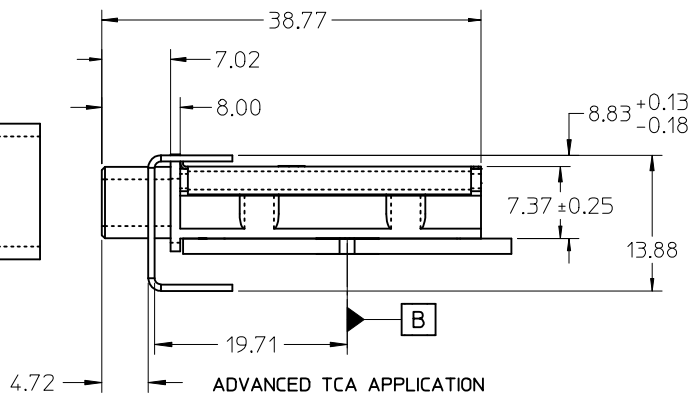
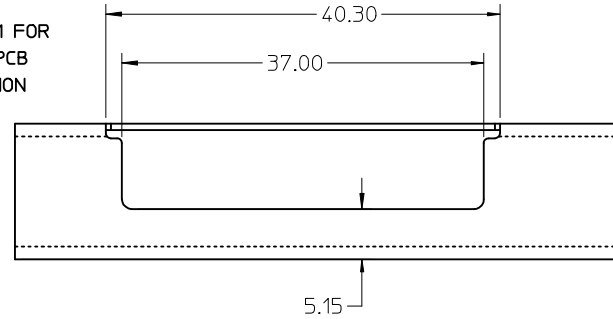

iPass™ is a trademark of Molex

SEE REVISION TABLE

EC NO: CPG2015-0143	2014/07/11
DRW:NEWANG07	2014/07/14
CHKD:SYANG16	2014/07/28
APPR:RCHEN08	

REV	DESCRIPTION
1	QUALITY SYMBOLS
2	QUALITY SYMBOLS
3	QUALITY SYMBOLS

GENERAL TOLERANCES (UNLESS SPECIFIED)	
	mm
4 PLACES	± 0.10
3 PLACES	± 0.15
2 PLACES	± 0.20
1 PLACE	± 0.25
0 PLACE	± 0.30
ANGULAR ± 1/2°	
DRAFT WHERE APPLICABLE MUST REMAIN WITHIN DIMENSIONS	

DIMENSION STYLE	
MM ONLY	
DRAWN BY	DATE
JERWIN	2006/05/25
CHECKED BY	DATE
BREED	2006/05/25
APPROVED BY	DATE
DDOYE	2006/05/25
MATERIAL NO.	
SEE P/N TABLE	

SCALE	DESIGN UNITS	THIRD ANGLE PROJECTION
2:1	METRIC	THIRD ANGLE PROJECTION
TITLE		
I-PASS X8 EMI GUIDE HOUSING ASSEMBLY W/ KEYS		
molex		
DOCUMENT NO.	SHEET NO.	
SD-74540-101	2 OF 4	

9 8 7 6 5 4 3 2 1

MOLEX P/N	DESCRIPTION	GEN
745400101	8x EMI Guide Housing Assembly - PCIe / 1 Deg	Gen 1
745400201	8x EMI Guide Housing Assembly - ATCA / 0 Deg	Gen 1

PCB THICKNESS	SCREW LENGTH	TORQUE (IN LBS)
1.6 (.063")	5MM	2.3
2.38 (.093")	6MM	2.3
3.2 (.125")	6MM	2.3
X	+4MM MAX	2.3

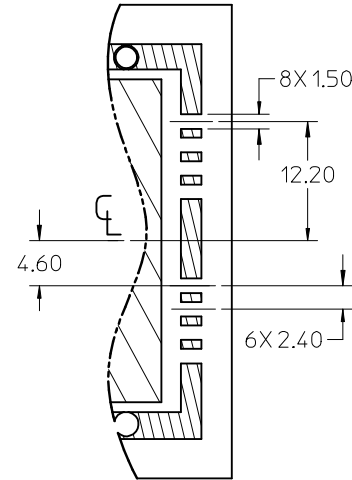

GROUND PAD ALLEY
LAYOUT INFORMATION



SEE REVISION TABLE EC NO: CPG2015-0143 DRAWN: WANG07 2014/07/11 CHKD: SYANG16 2014/07/14 APPR: RCHEN08 2014/07/28	QUALITY SYMBOLS ▽=0 ▽=0 ▽=0	GENERAL TOLERANCES (UNLESS SPECIFIED)		DIMENSION STYLE MM ONLY		SCALE 2:1	DESIGN UNITS METRIC	THIRD ANGLE PROJECTION	
		mm	INCH	DRAWN BY JERWIN	DATE 2006/05/25	TITLE I-PASS X8 EMI GUIDE HOUSING ASSEMBLY W/ KEYS	molex		
		4 PLACES	± ---	± ---	CHECKED BY BREED	DATE 2006/05/25	DOCUMENT NO. SD-74540-101		SHEET NO. 3 OF 4
		3 PLACES	± ---	± ---	APPROVED BY DDOYE	DATE 2006/05/25	MATERIAL NO.		
		2 PLACES	± 0.05	± ---	SEE P/N TABLE		SIZE B		
		1 PLACE	± 0.10	± ---	THIS DRAWING CONTAINS INFORMATION THAT IS PROPRIETARY TO MOLEX INCORPORATED AND SHOULD NOT BE USED WITHOUT WRITTEN PERMISSION				
		0 PLACE	±	±	ANGULAR ± 1/2°				
		DRAFT WHERE APPLICABLE MUST REMAIN WITHIN DIMENSIONS							

REVISION HISTORY

DATE (YEAR/MONTH/DAY)	REV	DESCRIPTION
2013/12/18	H	1. ADDED NOTES 10. MATERIAL: Ni PLATED ZINC DIECAST. [SHT 1] 2. CHANGED W/ NEW MOLEX FORMAT
2014/07/11	J	1. CHANGED 25.16 TO 25.09REF TO MEET PCI EXPRESS EXTERNAL CABLING SPECIFICATION @A9 [SHEET 1] 2. ADDED MM 3D NO. @F10 [SHEET 1] 3. THE MOLEX CHARACTER FIGURE UPDATE @F2 [SHEET 1], @F2 F5 [SHEET 2] 4. CHANGED 25.09 TO 25.09+/-0.1 @E9 [SHEET 2]

SEE REVISION TABLE EC NO: CPG2015-0143 DRW: NEWANG07 2014/07/11 CHKD: SYANG16 2014/07/14 APPR: RCHEN08 2014/07/28	QUALITY SYMBOLS	GENERAL TOLERANCES (UNLESS SPECIFIED)	DIMENSION STYLE	SCALE	DESIGN UNITS	THIRD ANGLE PROJECTION
	▽F/0	mm INCH	MM ONLY	1:1	METRIC	
	▽E/0	4 PLACES ± --- ± ---	DRAWN BY DATE			I-PASS X8 EMI GUIDE HOUSING ASSEMBLY W/ KEYS molex
	▽D/0	3 PLACES ± --- ± ---	JERWIN 2006/05/25			
	2 PLACES ± 0.05 ± ---	CHECKED BY DATE			DOCUMENT NO. SD-74540-101	
	1 PLACE ± 0.10 ± ---	BREED 2006/05/25				
	0 PLACE ± ±	APPROVED BY DATE			SHEET NO.	
	ANGULAR ± 1/2°	DDOYE 2006/05/25			4 OF 4	
	DRAFT WHERE APPLICABLE MUST REMAIN WITHIN DIMENSIONS	MATERIAL NO.	SEE P/N TABLE			
		SIZE B	THIS DRAWING CONTAINS INFORMATION THAT IS PROPRIETARY TO MOLEX INCORPORATED AND SHOULD NOT BE USED WITHOUT WRITTEN PERMISSION			