

## HSDL-9001

Miniature Surface-Mount  
Ambient Light Photo Diode



## Data Sheet

### Description

The HSDL-9001 is a low cost analog-output ambient light photo diode in lowest cost miniature Quad-Flat-No Lead (QFN) lead-free surface mount package. It consists of a photodiode, which peaks in human luminosity curve at 550 nm. Hence, it provides an excellent responsivity that is close to the response of human eyes, as shown in figure 2. It provides a design-alternative to the HSDL-9000 digital-output ambient light photo sensor with infinite ambient light detection threshold control. Both the HSDL-9000 and HSDL-9001 are ideal for applications in which the measurement of ambient light is used to control display backlighting. Mobile appliances such as the mobile phones and PDAs that draw heavy current from the display backlighting will benefit from incorporating the HSDL-9000 and HSDL-9001 in their designs to reduce the power consumption significantly.

### Features

- **Excellent responsivity which peaks in the human luminosity curve at 550 nm**  
Close responsivity to the human eye
- **Miniature QFN surface-mount package**  
Height – 0.60 mm  
Width – 2.00 mm  
Depth – 1.50 mm
- **Infinite ambient light detection threshold control**
- **Guaranteed temperature performance**  
–40°C to 85°C
- **V<sub>CC</sub> supply 2.7 to 3.6 V**
- **Lead-free and RoHS Compliant**

### Applications

- **Detection of ambient light to control display backlighting**  
Mobile devices – mobile phones, PDAs  
Computing devices – notebooks, webpads  
Consumer devices – TVs, video cameras, digital still cameras
- **Daylight and artificial light exposed devices**

### Application Support Information

The Application Engineering Group is available to assist you with the application design associated with HSDL-9001

infrared transceiver module. You can contact them through your local sales representatives for additional details.

### Ordering Information

Part Number	Packaging Type	Package	Quantity
HSDL-9001	Tape and Reel	2-Pin QFN Package	2500

### Typical Application Circuit

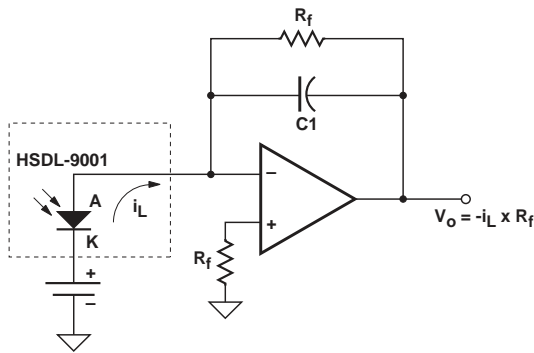

Figure 1. Typical application for HSDL-9001.

### I/ O Pins Configuration Table

Pin	Symbol	Description	Notes
1	K	Cathode	Regulated, 2.7 to 3.6 Volts
2	A	Anode	

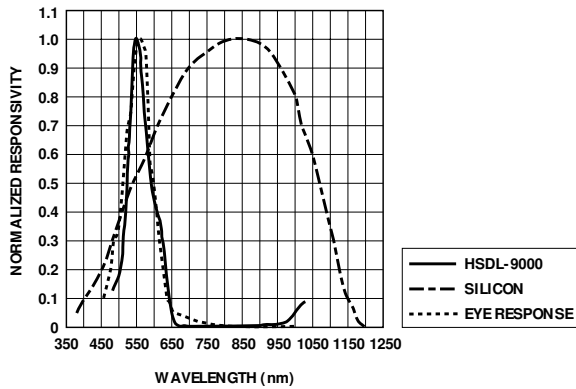

Figure 2. Relative spectral response vs. wavelength.

### Absolute Maximum Ratings

Parameter	Symbol	Min.	Max.	Units
Storage Temperature	T <sub>S</sub>	-40	85	°C
Operating Temperature	T <sub>A</sub>	-40	85	°C
Supply Voltage	V <sub>CC</sub>	2.7	3.6	V

### Recommended Operating Conditions

Parameter	Symbol	Min.	Max.	Units
Operating Temperature	T <sub>A</sub>	-40	85	°C
Supply Voltage	V <sub>CC</sub>	2.7	3.6	V

### Electrical & Optical Specifications

Specifications (Min. & Max. values) hold over the recommended operating conditions unless otherwise noted. Unspecified test conditions may be anywhere in their operating range.

All typical values (Typ.) are at 25°C with V<sub>CC</sub> at 3.0 V unless otherwise noted.

Parameter	Symbol	Min.	Typ.	Max.	Units	Conditions
Active Area Diameter	A <sub>D</sub>		0.65		mm <sup>2</sup>	
Peak Wavelength Sensitivity	λ <sub>p</sub>		550		nm	V <sub>CC</sub> = 0 V
Light Current	I <sub>ph</sub>		125		nA	V <sub>CC</sub> = 3 V, E <sub>v</sub> = 100 lux <sup>[1]</sup>
Dark Current	I <sub>d</sub>			5	nA	V <sub>CC</sub> = 3 V
Breakdown Voltage	V <sub>B</sub>	15			V	I <sub>B</sub> = 10 ∞A
Switching Time	t <sub>r</sub> , t <sub>f</sub>			2	ms	V <sub>CC</sub> = 3 V, E <sub>v</sub> = 500 lux, R = 500 kΩ <sup>[2]</sup>

#### Notes:

1. Illuminance by CIE standard light source (Incandescent Lamp).
2. Fluorescent light is used as light source. However, white LED is substituted in mass production.

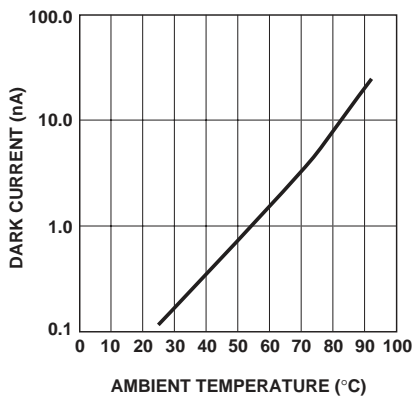

Figure 3a. Dark current vs. temperature.

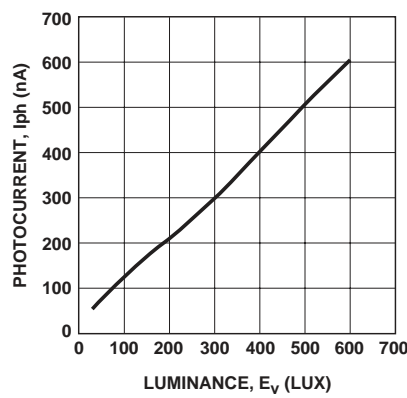

Figure 3b. Luminance vs. photocurrent.

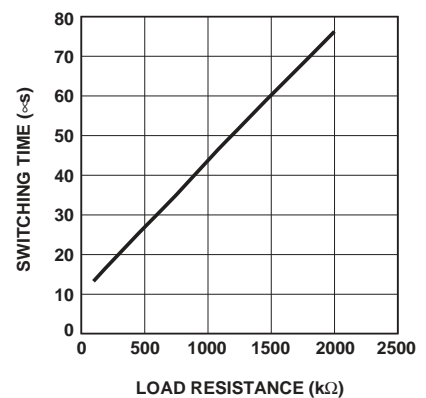
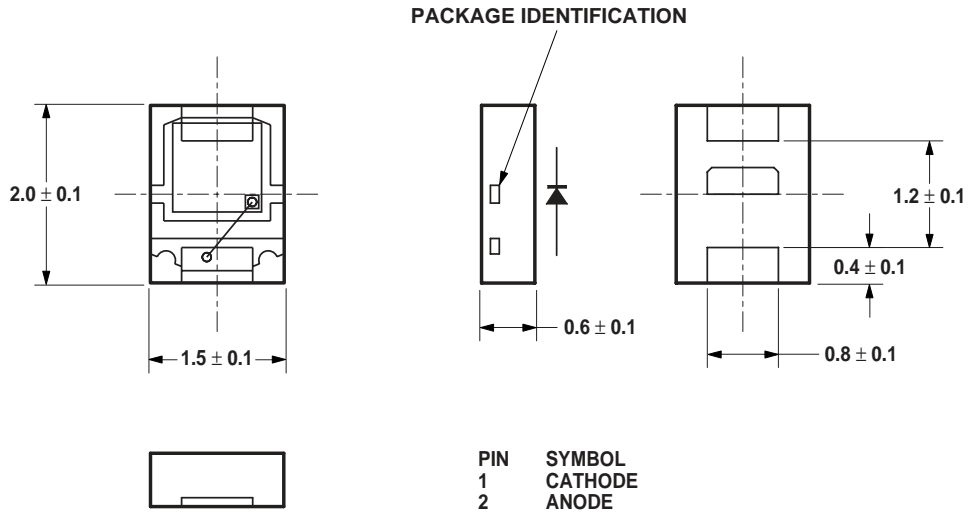
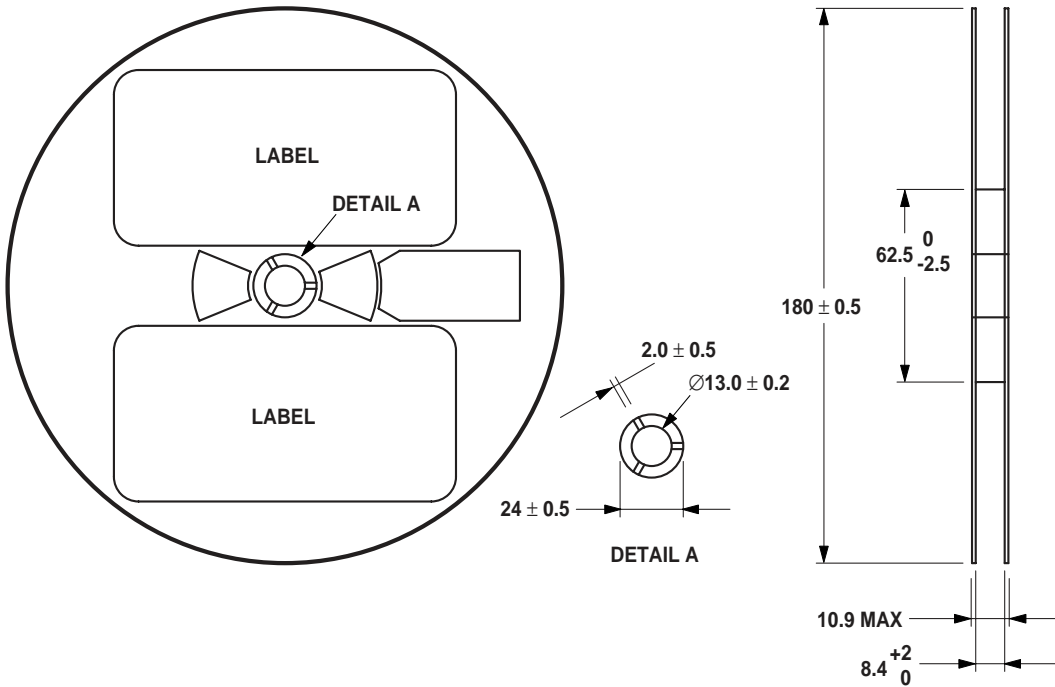
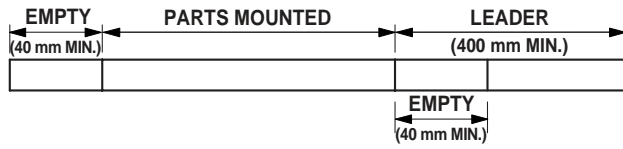
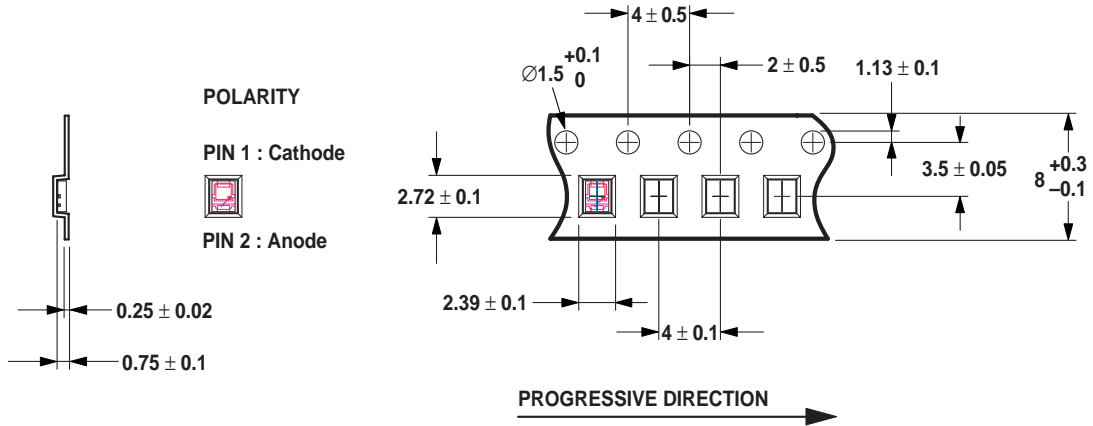

Figure 4. Switching characteristics.

# HSDL-9001 Package Outline



HSDL-9001 Tape and Reel Dimensions



**Moisture Proof Packaging**

All HSDL-9001 options are shipped in moisture proof package. Once opened, moisture absorption begins.

This part is compliant to JEDEC Level 2a.

**Baking Conditions**

If the parts are not stored in dry conditions, they must be baked before reflow to prevent damage to the parts.

Package	Temp.	Time
In reels	60°C	20 hours
In bulk	125°C	3 hours

Baking should only be done once.

**Recommended Storage Conditions**

Storage Temperature	10°C to 30°C
Relative Humidity	below 60% RH

**Time from Unsealing to Soldering**

After removal from the bag, the parts should be soldered within three days if stored at the recommended storage conditions. If times longer than four weeks are needed, the parts must be stored in a dry box.

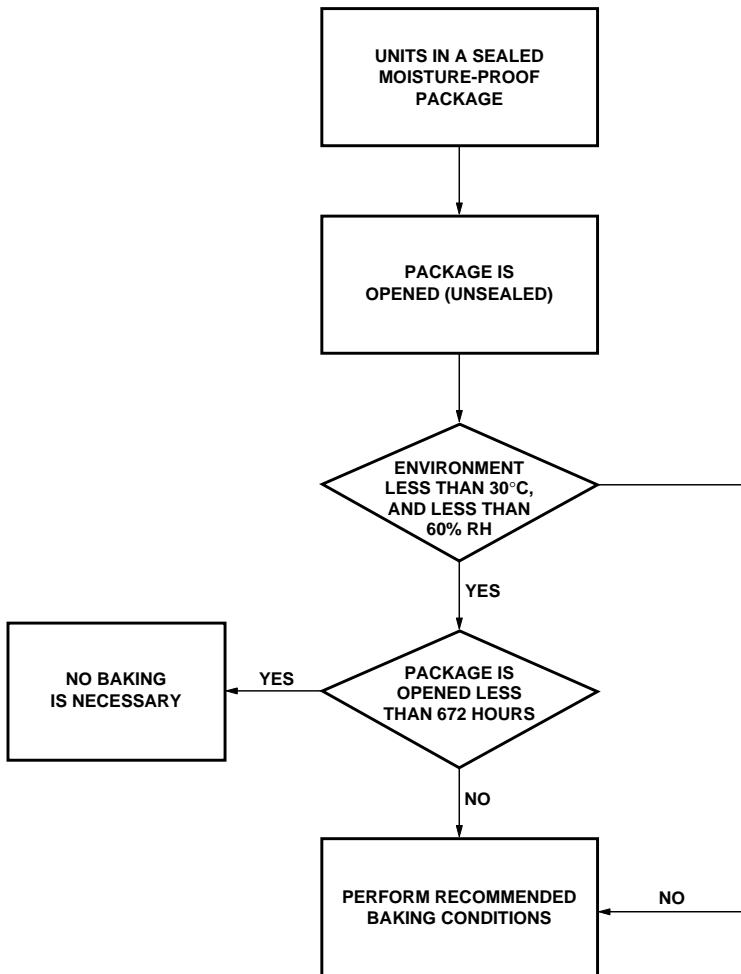

Figure 5. Baking conditions chart.

## Reflow Profile

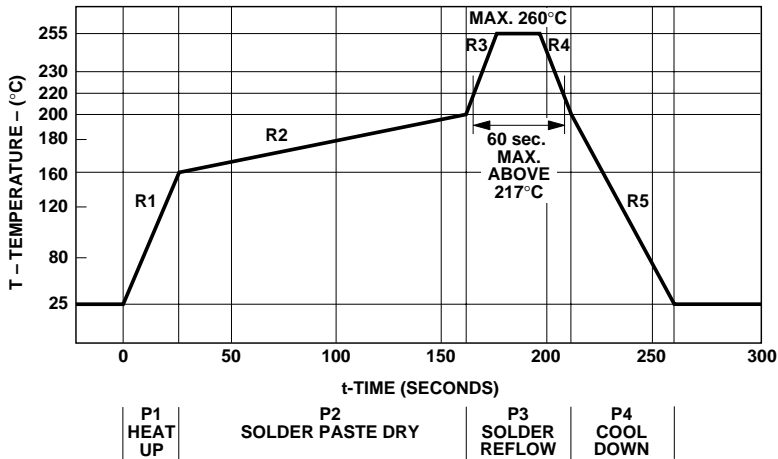

Figure 6. Reflow graph.

Process	Symbol	$\Delta T$	Maximum $\Delta T / \Delta \text{time}$
Heat Up	P1, R1	25°C to 160°C	4°C/ s
Solder Paste Dry	P2, R2	160°C to 200°C	0.5°C/ s
Solder Reflow	P3, R3	200°C to 255°C (260°C at 10 seconds max.)	4°C/ s
	P3, R4	255°C to 200°C	-6°C/ s
Cool Down	P4, R5	200°C to 25°C	-6°C/ s

The reflow profile is a straight-line representation of a nominal temperature profile for a convective reflow solder process. The temperature profile is divided into four process zones, each with different  $\Delta T / \Delta \text{time}$  temperature change rates. The  $\Delta T / \Delta \text{time}$  rates detailed in the above table. The temperatures are measured at the component to printed circuit board connections.

In process zone P1, the PC board and I/O pins are heated to a temperature of 160°C to activate the flux in the solder paste. The temperature ramp up rate, R1, is limited to 4°C per second to allow for even heating of both the PC board and HSDL-9001 I/O pins.

Process zone P2 should be of sufficient time duration (60 to 120 seconds) to dry the solder paste. The temperature is raised to a level just below the liquidus point of the solder, usually 200°C (392°F).

Process zone P3 is the solder reflow zone. In zone P3, the temperature is quickly raised above the liquidus point of solder to 255°C (491°F) for optimum results. The dwell time above the liquidus point of solder should be between 20 and 60 seconds. It usually takes about 20 seconds to assure proper coalescence of the solder balls into liquid solder and the formation of good solder connections. Beyond a dwell time of 60 seconds, the intermetallic

growth within the solder connections becomes excessive, resulting in the formation of weak and unreliable connections. The temperature is then rapidly reduced to a point below the solidus temperature of the solder, usually 200°C (392°F), to allow the solder within the connections to freeze solid.

Process zone P4 is the cool down after solder freeze. The cool down rate, R5, from the liquidus point of the solder to 25°C (77°F) should not exceed -6°C per second maximum. This limitation is necessary to allow the PC board and transceiver's castellated I/O pins to change dimensions evenly, putting minimal stresses on the HSDL-9001.

Appendix A : SMT Assembly Application Note

1.0 Solder Pad, Mask and Metal Stencil Aperture

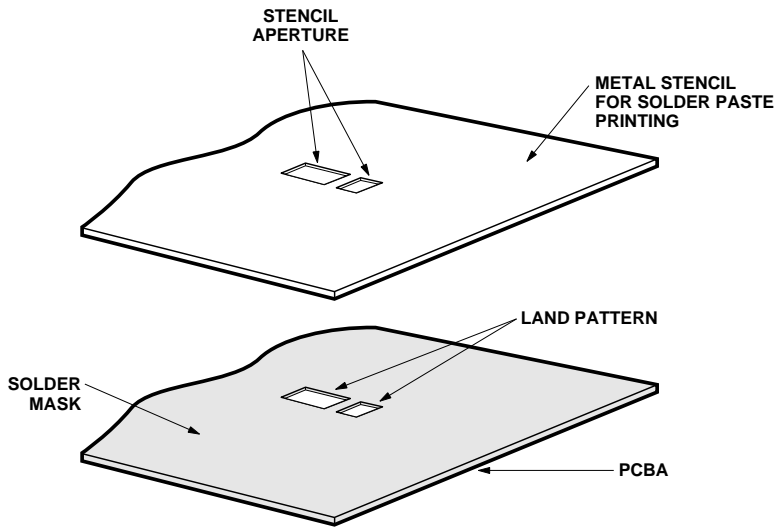

Figure 7. Stencil and PCBA.

1.1 Recommended Land Pattern

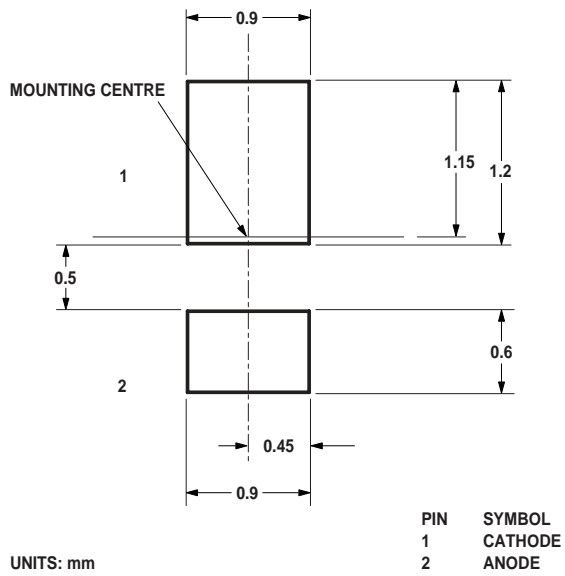

Figure 8. Recommended land pattern.



### 1.2 Recommended Metal Solder Stencil Aperture

It is recommended that only a 0.152 mm (0.006 inches) thick stencil be used for solder paste printing. This is to ensure adequate printed solder paste volume and no shorting.

Aperture opening for shield pad is as per land pattern.

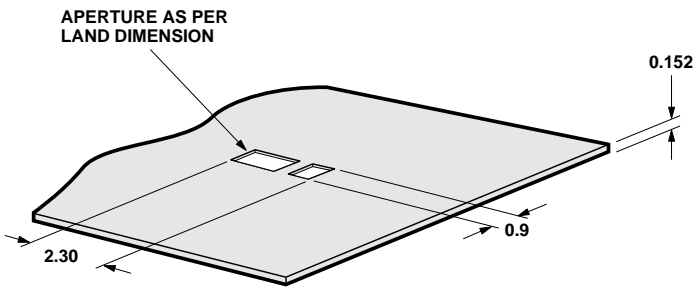

Figure 9. Solder stencil aperture.

### 1.3 Adjacent Land Keepout and Solder Mask Areas

Adjacent land keep-out is the maximum space occupied by the unit relative to the land pattern. There should be no other SMD components within this area.

The minimum solder resist strip width required to avoid solder bridging adjacent pads is 0.2 mm.

Note: Wet/Liquid Photo-Imageable solder resist/mask is recommended.

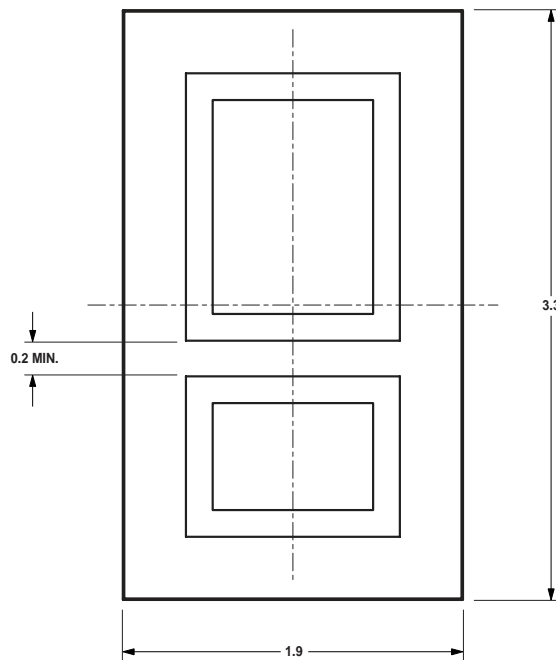

UNITS: mm

Figure 10. Adjacent land keepout and solder mask areas.

## Appendix B: Optical Window Design for HSDL-9001

### Optical Window Dimensions

To ensure that the performance of the HSDL-9001 will not be affected by improper window design, there are some constraints on the dimensions and design of the window. There is a constraint on the minimum size of the window, which is placed in front of the photodiode, so that it will not affect the angular response of the HSDL-9001. This minimum dimension that is recommended will ensure at least a  $\pm 35^\circ$  light reception cone.

If a smaller window is required, a light pipe or light guide can be used. A light pipe or light guide

is a cylindrical piece of transparent plastic which makes use of total internal reflection to focus the light.

The thickness of the window should be kept as minimum as possible because there is a loss of power in every optical window of about 8% due to reflection (4% on each side) and an additional loss of energy in the plastic material.

Figure 12 illustrates the two types of window that we have recommended which could either be a flat window or a flat window with light pipe.

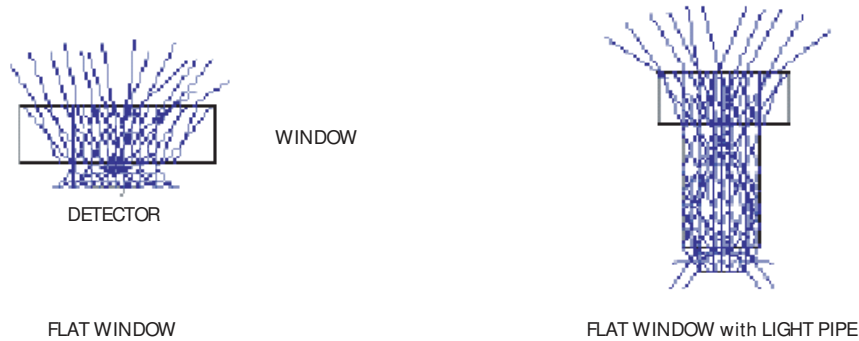

Figure 12. Recommended window design.

The table and figure below show the recommended dimensions of the window. These dimension values are based on a window thickness of 1.0 mm with a refractive index 1.585.

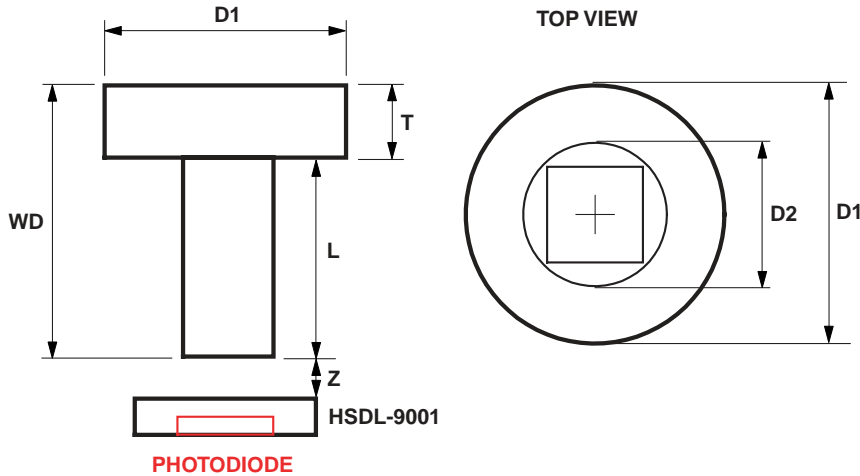

Figure 13. Recommended window dimensions.

- WD: Working Distance between window front panel & HSDL-9001
- D1: Window Diameter
- T: Thickness
- L: Length of Light Pipe
- D2: Light Pipe Diameter
- Z: Distance between window rear panel and HSDL-9001

**Recommended Dimension for Optical Window**

WD (T+ L+ Z)	Flat Window (L = 0.0)		Flat Window with Light Pipe (D2 = 1.5; z = 0.5)	
	Z	D1	D1	L
1.5	0.5	2.25	–	–
2.0	1.0	3.25	–	–
2.5	1.5	4.25	–	–
3.0	5.00	5.00	2.5	1.5

All Dimensions are in mm.

The window should be placed directly on top of the photodiode to achieve better performance and if a flat window with a light

pipe is used, dimension D2 should be 1.5 mm (same size as the PIN) to optimize the performance of HSDL-9001.

**Optical Window Material**

The material of the window is recommended to be polycarbonate. The surface finish of the plastic should be smooth, without any texture.

The recommended plastic material for use as a window is available from Bayer AG and Bayer Antwerp N. V. (Europe), Bayer Corp. (USA) and Bayer Polymers Co., Ltd. (Thailand).

**Recommended Plastic Material**

<b>Material Number</b>	<b>Visible Light Transmission</b>	<b>Refractive Index</b>
Makrolon LQ2647	87%	1.587
Makrolon LQ3147	87%	1.587
Makrolon LQ3187	85%	1.587

For product information and a complete list of distributors, please go to our website: [www.avagotech.com](http://www.avagotech.com)

Avago, Avago Technologies, and the A logo are trademarks of Avago Technologies Limited in the United States and other countries. Data subject to change. Copyright © 2006 Avago Technologies Limited. All rights reserved.  
5989-2299EN June 25, 2006

