

AC Controller with Isolated Water Flow

$I_{RMS} = 900\text{ A}$
 $V_{RRM} = 1200-1800\text{ V}$

Preliminary data

V_{RSM} V_{DSM} V	V_{RRM} V_{DRM} V	Type
1300	1200	HVL 900 - 12io1
1500	1400	HVL 900 - 14io1
1700	1600	HVL 900 - 16io1
1900	1800	HVL 900 - 18io1

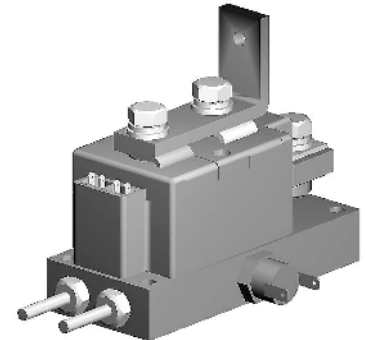
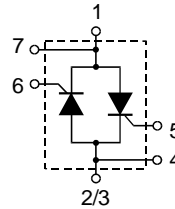

Symbol	Test Conditions	Maximum Ratings	
I_{RMS}	$T_{Water} = 17^{\circ}\text{C}$; watervolume = 4 l/min	900	A
I_{TSM} , I_{FSM}	$T_{VJ} = 45^{\circ}\text{C}$; $V_R = 0$	t = 10 ms (50 Hz) t = 8.3 ms (60 Hz)	9200 A 10100 A
	$T_{VJ} = T_{VJM}$ $V_R = 0$	t = 10 ms (50 Hz) t = 8.3 ms (60 Hz)	8000 A 8800 A
I^2t	$T_{VJ} = 45^{\circ}\text{C}$ $V_R = 0$	t = 10 ms (50 Hz) t = 8.3 ms (60 Hz)	423 000 A ² s 423 000 A ² s
	$T_{VJ} = T_{VJM}$ $V_R = 0$	t = 10 ms (50 Hz) t = 8.3 ms (60 Hz)	320 000 A ² s 321 000 A ² s
$(di/dt)_{cr}$	$T_{VJ} = T_{VJM}$ repetitive, $I_T = 960\text{ A}$ f = 50 Hz, $t_p = 200\ \mu\text{s}$ $V_D = 2/3 V_{DRM}$ $I_G = 1\text{ A}$, $di_G/dt = 1\text{ A}/\mu\text{s}$		100 A/ μs
$(dv/dt)_{cr}$	$T_{VJ} = T_{VJM}$; $V_{DR} = 2/3 V_{DRM}$ $R_{GK} = \infty$; method 1 (linear voltage rise)		1000 V/ μs
P_{GM}	$T_{VJ} = T_{VJM}$	$t_p = 30\ \mu\text{s}$	120 W
	$I_T = I_{TAVM}$	$t_p = 500\ \mu\text{s}$	60 W
P_{GAV}			20 W
V_{RGM}			10 V
T_{VJ}			-40...+140 °C
T_{VJM}			140 °C
T_{stg}			-40...+125 °C
V_{ISOL}	50/60 Hz, RMS t = 1 min		3000 V~
	$I_{ISOL} \leq 1\text{ mA}$ t = 1 s		3600 V~
Weight	Typical including screws		1300 g

Features

- Isolation between water and electrical connections with Direct copper bonded Al_2O_3 -ceramic
- Planar passivated chips
- Isolation voltage 3600 V~
- Keyed gate/cathode twin pins

Applications

- Large resistance welding equipment
- Large electroplating equipment

Data according to IEC 60747 refer to a single thyristor unless otherwise stated. IXYS reserves the right to change limits, test conditions and dimensions

Symbol	Test Conditions	Characteristic Values
I_{RRM}, I_{DRM}	$T_{VJ} = T_{VJM}; V_R = V_{RRM}; V_D = V_{DRM}$	40 mA
V_T, V_F	$I_T, I_F = 600 \text{ A}; T_{VJ} = 25^\circ\text{C}$	1.32 V
V_{T0}	For power-loss calculations only	0.8 V
r_T		0.68 mΩ
V_{GT}	$V_D = 6 \text{ V}; T_{VJ} = 25^\circ\text{C}$	2 V
	$T_{VJ} = -40^\circ\text{C}$	3 V
I_{GT}	$V_D = 6 \text{ V}; T_{VJ} = 25^\circ\text{C}$	150 mA
	$T_{VJ} = -40^\circ\text{C}$	220 mA
V_{GD}	$T_{VJ} = T_{VJM}; V_D = 2/3 V_{DRM}$	0.25 V
I_{GD}	$T_{VJ} = T_{VJM}; V_D = 2/3 V_{DRM}$	10 mA
I_L	$T_{VJ} = 25^\circ\text{C}; t_p = 30 \mu\text{s}; V_D = 6 \text{ V}$ $I_G = 0.45 \text{ A}; di_G/dt = 0.45 \text{ A}/\mu\text{s}$	200 mA
I_H	$T_{VJ} = 25^\circ\text{C}; V_D = 6 \text{ V}; R_{GK} = \infty$	150 mA
t_{gd}	$T_{VJ} = 25^\circ\text{C}; V_D = 1/2 V_{DRM}$ $I_G = 1 \text{ A}; di_G/dt = 1 \text{ A}/\mu\text{s}$	2 μs
Q_S	$T_{VJ} = 125^\circ\text{C}; I_T, I_F = 300 \text{ A}; -di/dt = 50 \text{ A}/\mu\text{s}$	760 μC
I_{RM}		275 A
R_{thJW}	per thyristor ; 180° el; watervolume = 4 l/min	0.203 K/W
d_S	Creeping distance on surface	12.7 mm
d_A	Creepage distance in air	
a	Maximum allowable acceleration	

Optional accessories for modules

Keyed Gate/Cathode twin plugs with wire length = 350 mm, gate = yellow, cathode = red
 Type **ZY 180 L** (L = Left for pin pair 4/5) } UL 758, style 1385,
 Type **ZY 180 R** (R = Right for pin pair 6/7) } CSA class 5851, guide 460-1-1

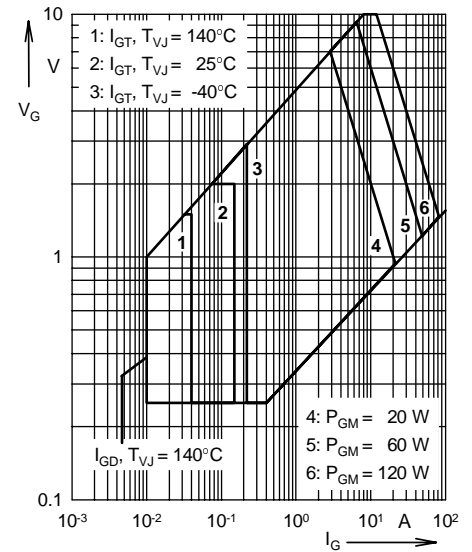
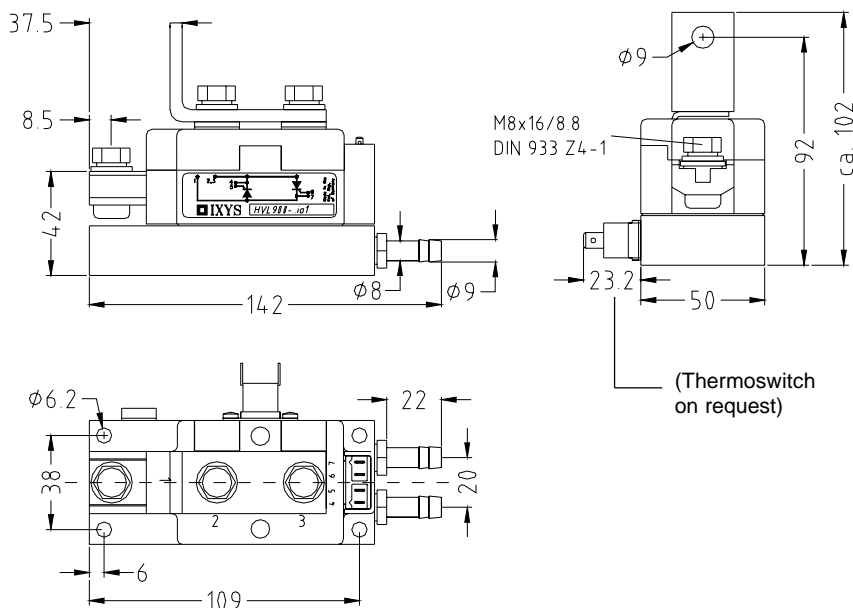

Fig. 1 Gate trigger characteristics

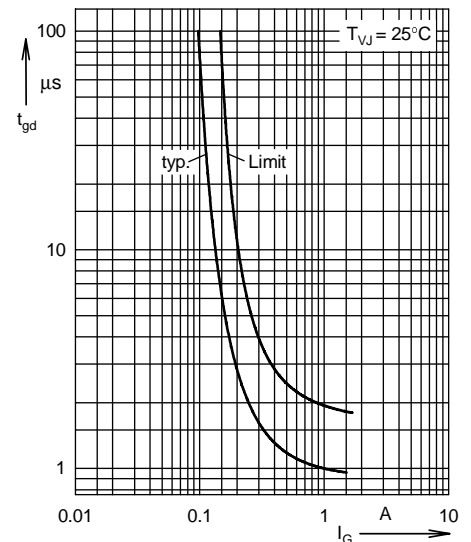

Fig. 2 Gate trigger delay time

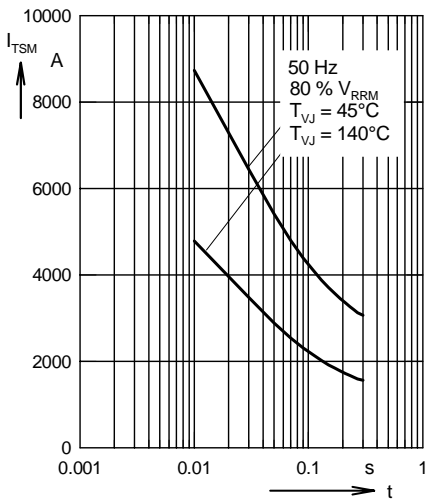

Fig. 3 Surge overload current
 I_{TSM} : Crest value, t : duration

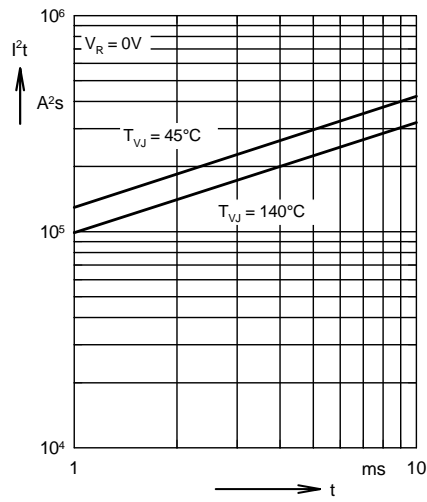

Fig. 4 I^2t versus time (1-10 ms)

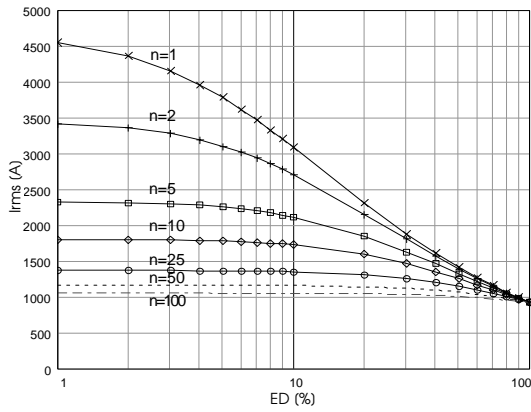

Fig. 5 Rated rms current vs. duty cycle

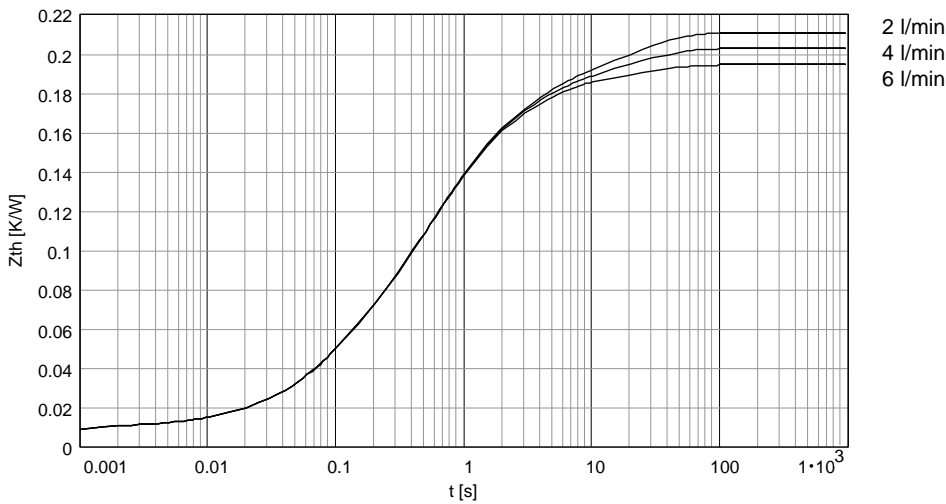

Fig. 6 Transient thermal impedance vs. time