

### Features

- Low  $I_R$  (<100 nA @ 1 V, <500 nA @ 3 V)
- Designed for High Volume, Low Cost Detector & Mixer Applications
- High Detector Sensitivity: -55 dBm TSS
- Low Capacitance: 0.30 pF
- Low 1/F Noise
- Single, Series Pair, and Unconnected Pair Configurations
- Lead Free
- RoHS\* Compliant
- Tape and Reel

### Description and Applications

The MA4E2054 series are low barrier N-type silicon Schottky diodes assembled in surface mount plastic packages. They are designed for use as high performance mixer and detector diodes.

The MA4E20541-1141T (SOD-323), MA4E20541-1279T (SC-79) and MA4E2054A1(SOT-23) are single element Schottky diodes characterized for use as single ended mixers and detectors. The MA4E2054B1 and MA4E2054D1 (available in both the SOT-23 and SOT-323 packages) incorporate two Schottky chips in series pair configurations. These diodes are useful for balanced mixer and detector voltage doubler circuits.

Applications for the MA4E2054 series include VSAT and DBS mixers. The small diode package size and low cost make them attractive for use in RF tag applications for identification and toll collection.

### Package Outlines

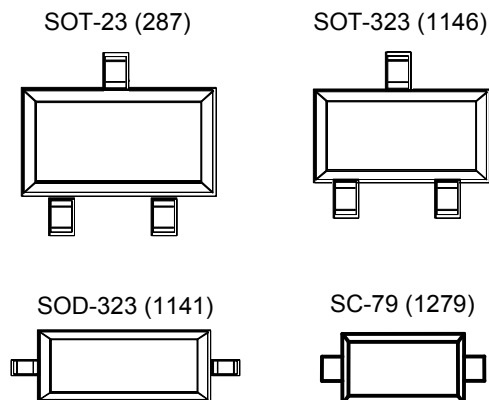

### Part Numbers

Part Number	Package Style
MA4E2054A1-287T	SOT-23
MA4E2054B1-287T	SOT-23
MA4E2054B1-1146T	SOT-323
MA4E2054D1-287T	SOT-23
MADS-002054-1146DT	SOT-323
MA4E20541-1141T	SOD-323
MA4E20541-1279T	SC-79

1. The part number consists of the base chip (MA4E2054), followed by the wiring configuration (A, B, D, omit for SOD-323), the package style (287, 1141, 1146) and a "T" for tape and reel.

### Configurations (Top View)

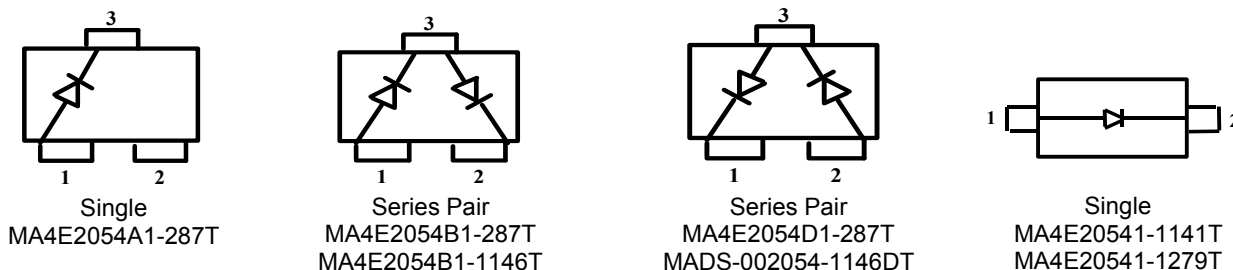

\* Restrictions on Hazardous Substances, compliant to current RoHS EU directive.

## Surface Mount Low Barrier Schottky Diode

Rev. V13

### Electrical Specifications @ +25°C<sup>2,3</sup>

Parameter	Condition	Specification
Breakdown Voltage ( $V_B$ )	$I_R = 10 \mu A$	3.0 V min.
Reverse Leakage Current ( $I_R$ )	$V_R = 1 V$ $V_R = 3 V$	100 nA max. 500 nA max.
Total Capacitance ( $C_T$ )	$V_R = 0 V, F = 1 MHz$	0.3 pF max.
Dynamic Resistance ( $R_D$ ) <sup>2</sup>	$I_F = 10 mA$	17 $\Omega$ max.
Forward Voltage ( $V_F$ )	$I_F = 1 mA$	250 mV min. 350 mV max.
Delta Forward Voltage(D $V_F$ )	$I_F = 1 mA$	20 mV max.

2. Applies to MA4E2054B and MA4E2054D configurations.

3.  $R_D = R_S + R_J$  where  $R_J = \frac{26}{I_F}$  (in mA)

### Typical RF Performance @ +25°C in Chip Form, Mounted on a Microstrip Fixture

Parameter	Condition	Specification
Mixer Noise Figure	$F = 9.375 GHz, LO = 0 dBm$	5.7 dB (SSB)
IF Impedance	$I_F = 30 MHz$	200 ohms
Tangential Signal, Sensitivity	$F = 2.5 GHz, I_F = 20 mA,$ $BW = 2 MHz, Video NF = 1.5 dB$	-55 dBm
Detector Output, Voltage at -30 dBm	$R_L = 100 k\Omega, I_F = 20 mA$	20 mV
Detector Output, Voltage at -30 dBm	$R_L = 1 M \Omega, Zero Bias$	20 mV

4. See Performance Curves on page 4 for untuned fixture performance.

### Maximum Ratings @ 25°C (unless otherwise specified)<sup>5,6</sup>

Parameter	Values
Operating Temperature	-65°C to +125°C
Storage Temperature	-65°C to +125°C
RF Incident Power (CW)	75 mW <sup>7</sup>
Forward Current	20 mA
Reverse Voltage	3 V
Soldering Temperature	+260°C for 5 sec.

5. Operation of this device above any one of the Maximum Rated parameters may cause permanent damage.

6. Please refer to Application Note M538 for surface mounting instructions.

7. Derate linearly to 0 W @ 125°C case temperature.

### Circuit Models

#### SOT-23

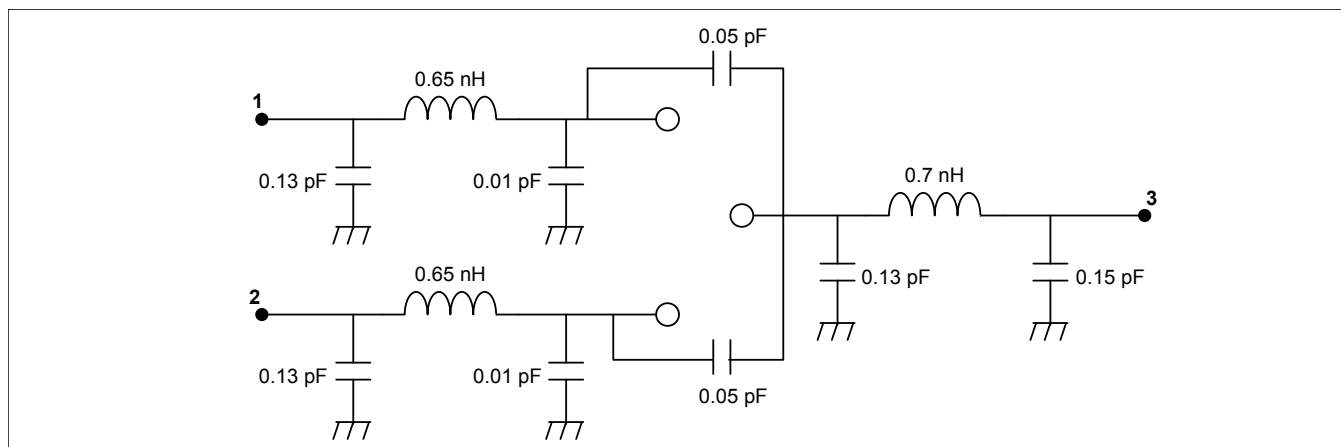

#### SOT-323

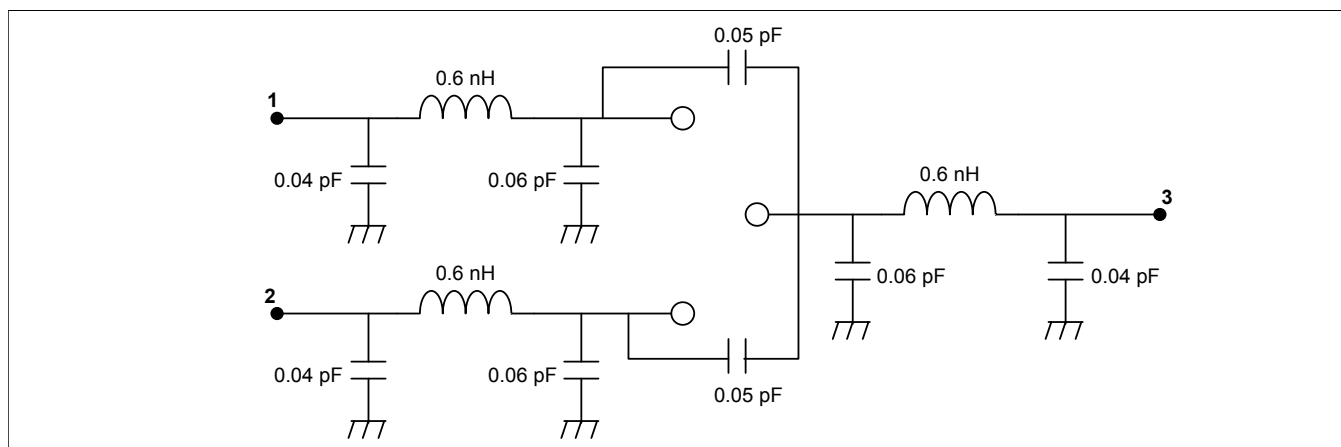

#### SOD-323

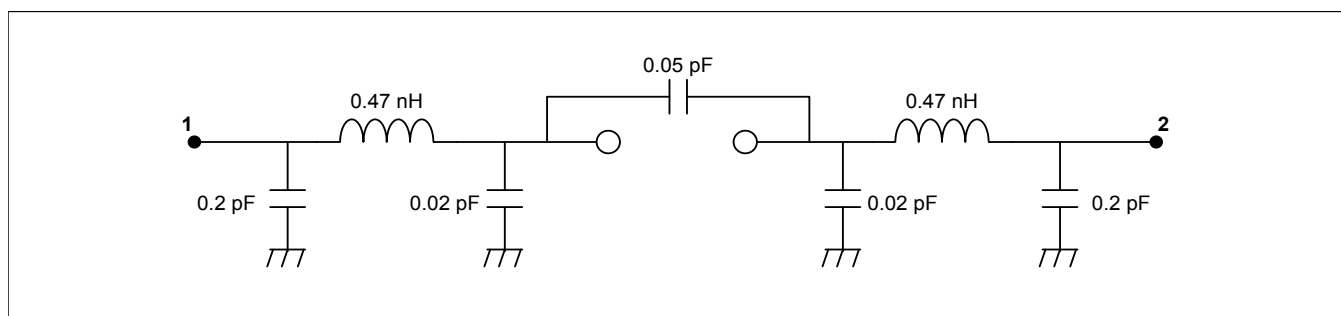

## Surface Mount Low Barrier Schottky Diode

Rev. V13

### Typical Performance Curves @ +25°C in Chip Form, Mounted on a Microstrip Fixture

**Detector Output Voltage vs. Frequency and Load Resistance at -30 dBm. Diode Forward Biased at 20μA. Untuned Fixture (50 Ω)**

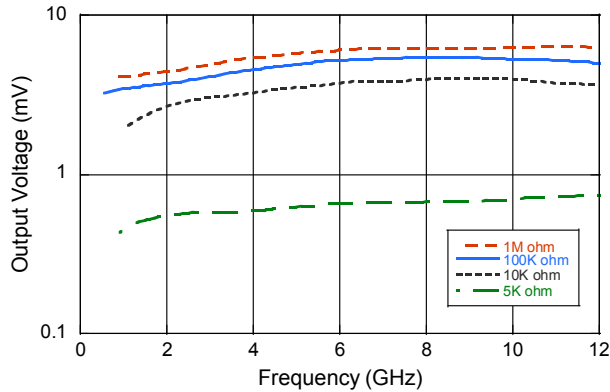

**Detector Output Voltage vs. Frequency and Load Resistance at -30 dBm. Diode at Zero Bias. Untuned Fixture.**

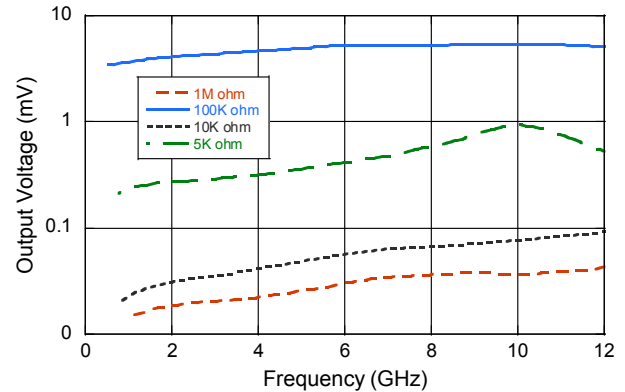

**Detector Output Voltage vs. Input Power and Load Resistance. Diode Forward Biased at 20μA. Untuned Fixture at 9.375 GHz.**

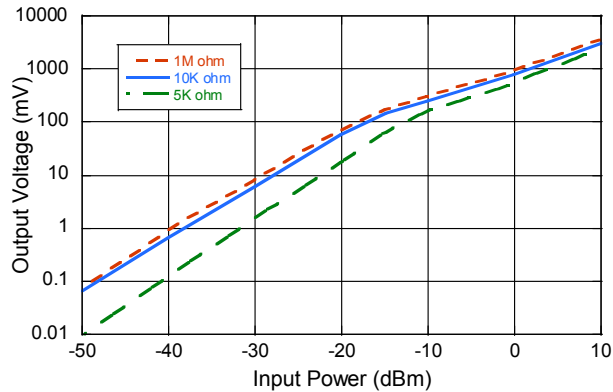

**Detector Output Voltage vs. Input Power and Load Resistance. Diode at Zero Bias. Untuned Fixture at 9.375 GHz (50Ω)**

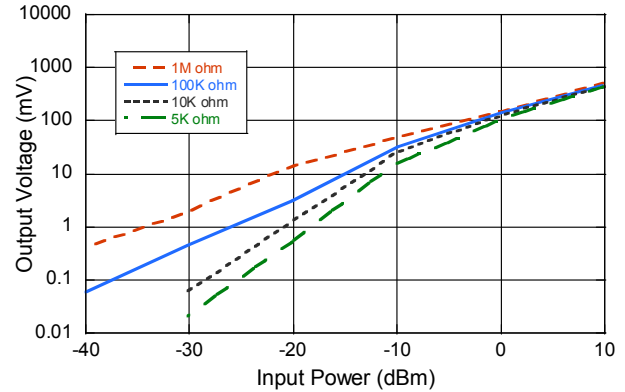

**Forward Current vs. Forward Voltage and Temperature**

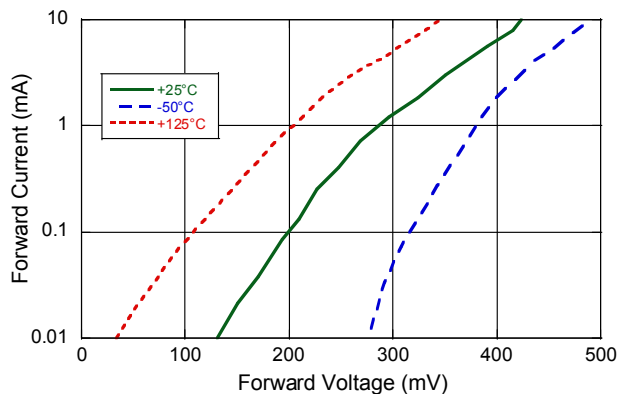

**Noise Figure vs. Lo Power at 9.375 GHz Tuned Fixture**

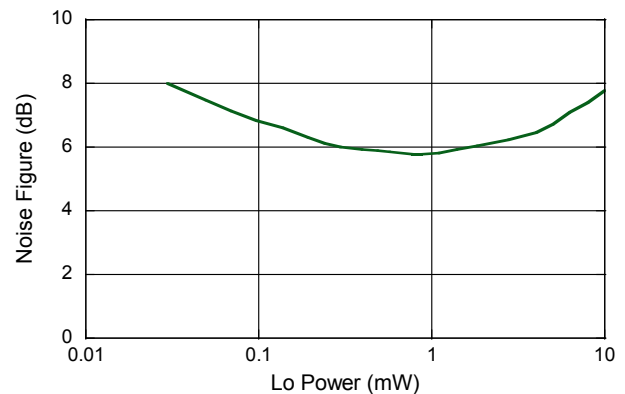

### Case Styles

#### SOT-23

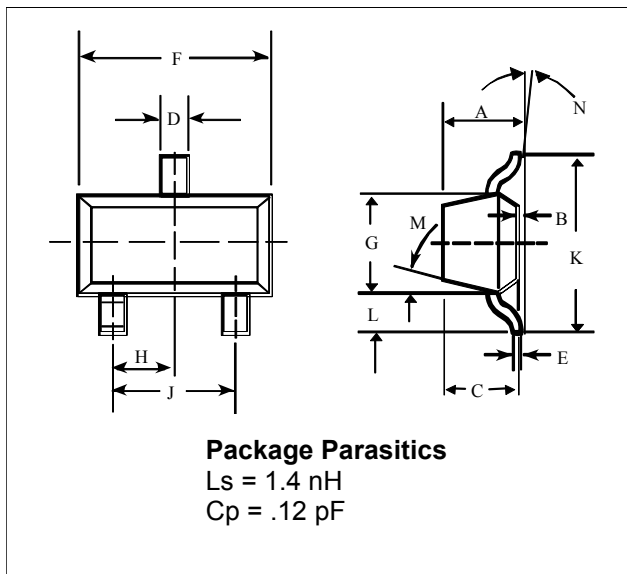

#### SOT-23 (Case Style 287)

Dim.	Inches		Millimeters	
	Min.	Max.	Min.	Max.
A	—	0.048	—	1.22
B	—	0.008	—	0.20
C	—	0.040	—	1.00
D	0.013	0.020	0.35	0.50
E	0.003	0.006	0.08	0.15
F	0.110	0.119	2.80	3.00
G	0.047	0.056	1.20	1.40
H	0.037 typical		0.95 typical	
J	0.075 typical		1.90 typical	
K	—	0.103	—	2.60
L	—	0.024	—	0.60
Dim.	Gradient			
M	10° max. <sup>3</sup>			
N	2° . . .30°			

3. Applicable on all sides

#### SOT-323

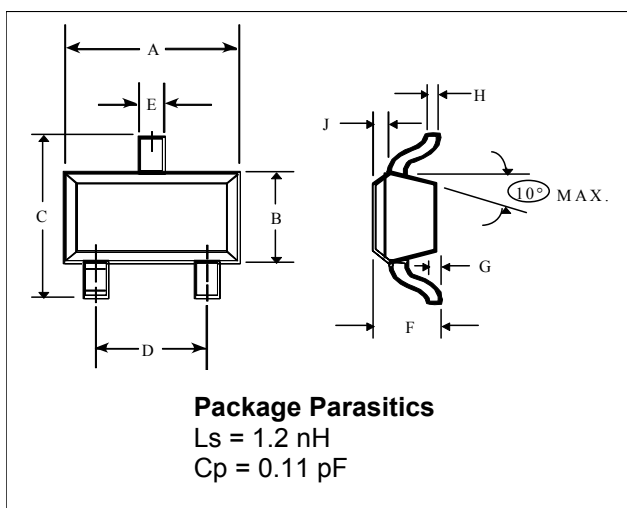

#### SOT-323 (Case Style 1146)

Dim.	Inches		Millimeters	
	Min.	Max.	Min.	Max.
A	0.063	0.087	1.6	2.2
B	0.045	0.053	1.15	1.35
C	0.079	0.087	2.0	2.2
D	0.047	0.055	1.2	1.4
E	0.008	0.016	0.2	0.4
F	0.031	0.039	0.8	1.0
G	—	0.004	—	0.1
H	0.003	0.006	0.08	0.15
J	0.004	0.010	0.1	0.25

### Case Styles (Cont'd)

#### SOD-323

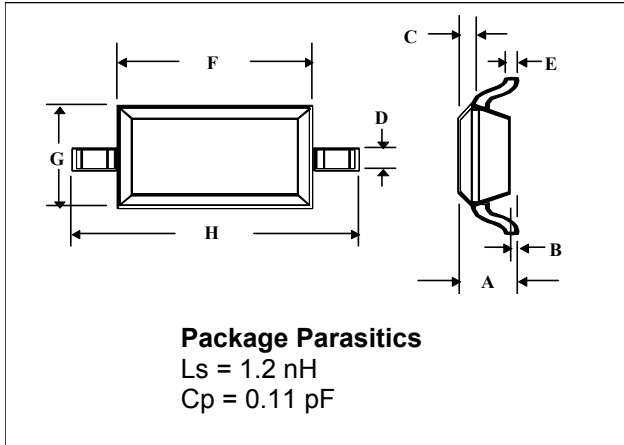

#### SOD-323 (Case Style 1141)

Dim.	Inches		Millimeters	
	Min.	Max.	Min.	Max.
A	—	0.043	—	1.1
B	—	0.004	—	0.1
C	—	0.008	—	0.2
D	0.010	0.016	0.25	0.4
E	0.003	0.006	0.08	0.15
F	0.063	0.075	1.6	1.9
G	0.045	0.057	1.15	1.45
H	0.091	0.106	2.3	2.7

#### SC-79

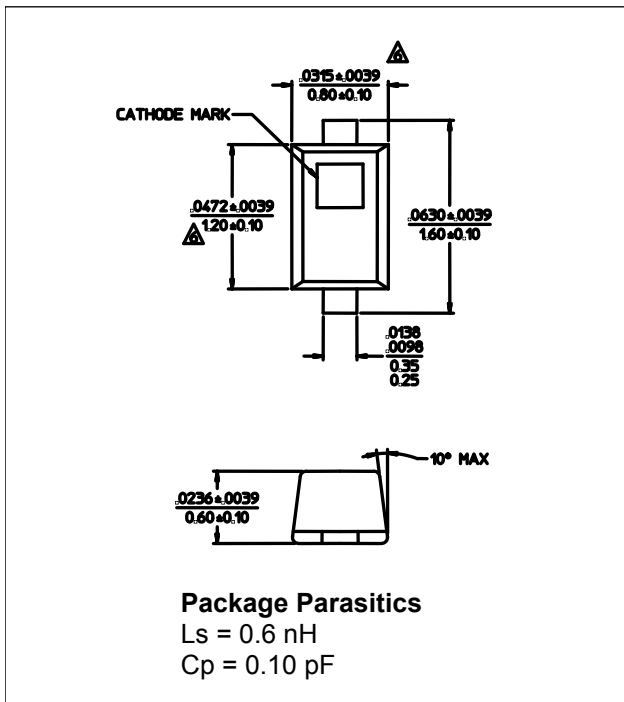

#### SC-79 (Case Style 1279)

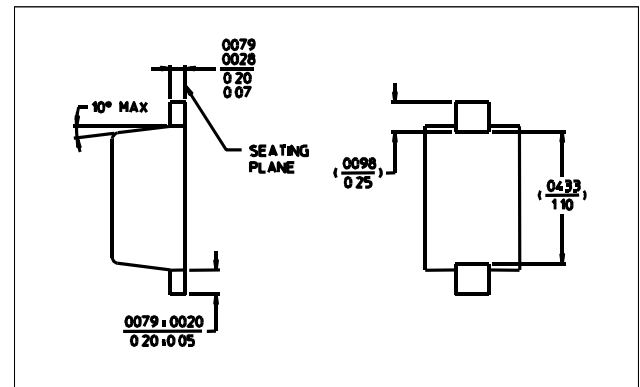

### Spice Model Parameters

IS = $3 \times 10^{-8}$ A	M = 0.50
RS = 11Ω	EG = 0.69 eV
N = 1.05	BV = 5.0 V
TT = 0 S	IBV = $1 \times 10^{-5}$ A
Cj(0) = $0.13 \times 10^{-12}$ pF	
Cpar = $0.14 \times 10^{-12}$ pF	
VJ = 0.40 V	

### Typical Scattering Parameters (S11)

MA4E2054A Chip Form, Mounted on a Microstrip Fixture (no DC bias)

Freq. GHz	-30 dBm		-3 dBm		0 dBm		3 dBm	
	MAG	PHASE	MAG	PHASE	MAG	PHASE	MAG	PHASE
0.50	0.993	-7.6	0.812	-7.0	0.597	-4.6	0.387	-0.9
1.00	0.994	-15.1	0.843	-14.7	0.632	-13.9	0.411	-11.3
1.50	0.993	-21.4	0.807	-21.7	0.596	-22.3	0.386	-22.4
2.00	0.997	-27.1	0.791	-26.0	0.580	-23.1	0.383	-16.4
2.50	0.994	-33.2	0.795	-31.5	0.579	-27.6	0.378	-18.5
3.00	0.994	-41.3	0.755	-42.7	0.548	-45.2	0.342	-48.6
3.50	0.992	-48.6	0.727	-52.2	0.524	-55.8	0.318	-60.8
4.00	0.997	-56.5	0.713	-58.9	0.502	-59.5	0.296	-56.3
4.50	0.987	-66.4	0.696	-67.1	0.464	-67.7	0.235	-62.6
5.00	0.971	-74.7	0.634	-79.8	0.386	-86.2	0.167	-94.9
5.50	0.965	-83.1	0.614	-88.6	0.354	-91.4	0.131	-98.7
6.00	0.980	-96.0	0.547	-103.5	0.292	-107.0	0.072	-117.2
6.50	0.974	-110.3	0.514	-120.1	0.248	-129.5	0.041	163.9
7.00	0.941	-123.7	0.450	-137.4	0.235	-150.8	0.070	145.2
7.50	0.957	-138.9	0.430	-158.1	0.247	178.0	0.152	120.6
8.00	0.969	-155.6	0.404	-178.8	0.260	150.1	0.218	102.5
8.50	0.933	-171.5	0.405	162.2	0.294	129.9	0.278	92.0
9.00	0.932	170.9	0.391	143.1	0.310	110.8	0.344	84.4
9.50	0.943	152.8	0.410	128.2	0.318	97.9	0.343	68.7
10.00	0.931	132.2	0.504	108.9	0.394	83.3	0.399	56.9

MACOM Technology Solutions Inc. All rights reserved.

Information in this document is provided in connection with MACOM Technology Solutions Inc ("MACOM") products. These materials are provided by MACOM as a service to its customers and may be used for informational purposes only. Except as provided in MACOM's Terms and Conditions of Sale for such products or in any separate agreement related to this document, MACOM assumes no liability whatsoever. MACOM assumes no responsibility for errors or omissions in these materials. MACOM may make changes to specifications and product descriptions at any time, without notice. MACOM makes no commitment to update the information and shall have no responsibility whatsoever for conflicts or incompatibilities arising from future changes to its specifications and product descriptions. No license, express or implied, by estoppel or otherwise, to any intellectual property rights is granted by this document.

THESE MATERIALS ARE PROVIDED "AS IS" WITHOUT WARRANTY OF ANY KIND, EITHER EXPRESS OR IMPLIED, RELATING TO SALE AND/OR USE OF MACOM PRODUCTS INCLUDING LIABILITY OR WARRANTIES RELATING TO FITNESS FOR A PARTICULAR PURPOSE, CONSEQUENTIAL OR INCIDENTAL DAMAGES, MERCHANTABILITY, OR INFRINGEMENT OF ANY PATENT, COPYRIGHT OR OTHER INTELLECTUAL PROPERTY RIGHT. MACOM FURTHER DOES NOT WARRANT THE ACCURACY OR COMPLETENESS OF THE INFORMATION, TEXT, GRAPHICS OR OTHER ITEMS CONTAINED WITHIN THESE MATERIALS. MACOM SHALL NOT BE LIABLE FOR ANY SPECIAL, INDIRECT, INCIDENTAL, OR CONSEQUENTIAL DAMAGES, INCLUDING WITHOUT LIMITATION, LOST REVENUES OR LOST PROFITS, WHICH MAY RESULT FROM THE USE OF THESE MATERIALS.

MACOM products are not intended for use in medical, lifesaving or life sustaining applications. MACOM customers using or selling MACOM products for use in such applications do so at their own risk and agree to fully indemnify MACOM for any damages resulting from such improper use or sale.