

## Programmable USB Type-C Controller

### General Description

The RT1730 is a USB Type-C controller that complies with the latest USB Type-C. The RT1730 integrates a complete Type-C Transceiver including the Rp and Rd resistors. It does the USB Type-C detection including attach and orientation.

### Ordering Information

RT1730 □  
 Package Type  
 WSC : WL-CSP-9B 1.38x1.34 (BSC)

Note :

Richtek products are :

- ▶ RoHS compliant and compatible with the current requirements of IPC/JEDEC J-STD-020.
- ▶ Suitable for use in SnPb or Pb-free soldering processes.

### Marking Information

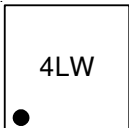

4L : Product Code  
 W : Date Code

### Features

- Attach/Detach Detection as Host, Device or DRP
- Dead Battery Support
- Ultra-low Power Mode for Attach Detection
- Simple I<sup>2</sup>C Interface with AP or EC
- e-fuse IP
- 9-Ball WL-CSP Package

### Applications

- Smartphones
- Tablets
- Laptops

### Pin Configuration

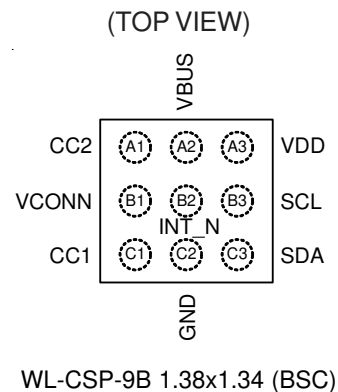

Functional Pin Description

Pin No.	Pin Name	Pin Function
A1	CC2	Type-C connector Configuration Channel (CC) pins. Initially used to determine when an attach has occurred and what the orientation detected.
A2	VBUS	VBUS input pin for attach and detach detection when operating as an UFP port (Device).
A3	VDD	Input supply voltage.
B1	VCONN	Regulated input pin to be switched to correct CC pin as VCONN to power Type-C full-featured cables and other accessories.
B2	INT_N	Active low and open drain type interrupt output used to prompt the processor to read the registers.
B3	SCL	I <sup>2</sup> C serial data signal to be connected to the I <sup>2</sup> C master.
C1	CC1	Type-C connector Configuration Channel (CC) pins. Initially used to determine when an attach has occurred and what the orientation detected.
C2	GND	Ground.
C3	SDA	I <sup>2</sup> C serial data signal to be connected to the I <sup>2</sup> C master.

Functional Block Diagram

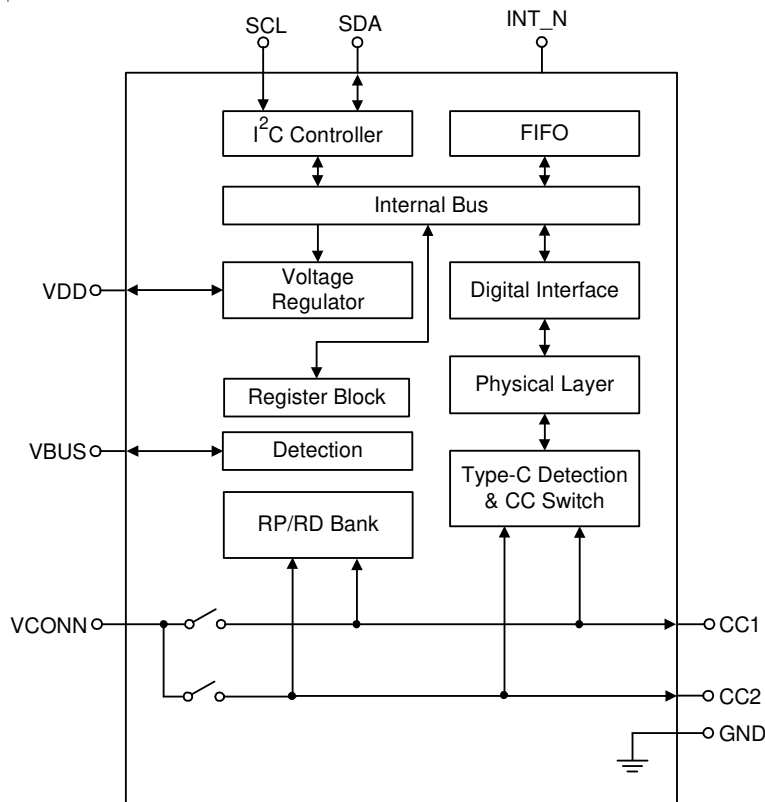

**Absolute Maximum Ratings** (Note 1)

- VDD/VCONN ----- -0.3V to 6V
- CC1/CC2 ----- -0.3V to 24V
- VBUS ----- -0.3V to 28V
- Power Dissipation, P<sub>D</sub> @ T<sub>A</sub> = 25°C  
 WL-CSP-9B 1.38x1.34 (BSC) ----- 1.22W
- Package Thermal Resistance (Note 2)  
 WL-CSP-9B 1.38x1.34 (BSC), θ<sub>JA</sub> ----- 81.5°C/W
- Lead Temperature (Soldering, 10 sec.) ----- 260°C
- Junction Temperature ----- 150°C
- Storage Temperature Range ----- -65°C to 150°C
- ESD Susceptibility (Note 3)  
 HBM (Human Body Model) ----- 2kV

**Recommended Operating Conditions** (Note 4)

- Supply Input Voltage ----- 2.7V to 5.5V
- VCON Supply Current ----- 200 to 600mA
- VCON Supply Voltage ----- 4.75V to 5.5V
- Junction Temperature Range ----- -40°C to 125°C
- Ambient Temperature Range ----- -40°C to 85°C

**Electrical Characteristics**

(V<sub>DD</sub> = 3.3V, T<sub>A</sub> = 25°C, unless otherwise specified.)

Parameter	Symbol	Test Conditions	Min	Typ	Max	Unit
<b>Power Consumption</b>						
Operation Current	I <sub>SB</sub>	Cable attached (Full function on)	--	2.8	--	mA
Ultra-Low Power Mode	I <sub>UL</sub>	VCONN5V supply on, DRP toggle	--	I <sub>VDD</sub> = 20	30	μA
		VCONN5V supply off, DRP toggle	--	I <sub>VCONN5V</sub> = 25	--	
			--	10	30	
<b>Type-C Port Control</b>						
Ron for VCONN Switch	R <sub>ON</sub>		--	1	--	Ω
OCP Range	I <sub>OCP</sub>		200	--	600	mA
Time for VCONN Switch to Turn-On State	t <sub>SOFT</sub>		--	1.2	--	ms
DFP 80μA CC Current	DFP <sub>80μ</sub>		64	80	96	μA
DFP 180μA CC Current	DFP <sub>180μ</sub>		166	180	194	μA
DFP 330μA CC Current	DFP <sub>330μ</sub>		304	330	356	μA

Parameter	Symbol	Test Conditions	Min	Typ	Max	Unit
UFP Rd	Rd		4.59	5.1	5.61	k $\Omega$
UFP pull-down Voltage in Dead Battery Under DFP <sub>80<math>\mu</math></sub> and DFP <sub>180<math>\mu</math></sub> A	V <sub>DBL</sub>		--	--	1.6	V
UFP Pull-Down Voltage in Dead Battery Under DFP <sub>330<math>\mu</math></sub> A	V <sub>DBH</sub>		--	--	2.6	V
VBUS Detection Valid Voltage			--	4	--	V
VBUS Measure Range			5	--	20	V
VBUS Measurement Step when VBUS Range Under 4 to 10V			--	0.5	--	V
VBUS Measurement Step when VBUS Range Under 10 to 20V			--	1	--	V
<b>I<sup>2</sup>C Electrical Characteristics</b>						
I <sup>2</sup> C Bus Supply Voltage	I <sup>2</sup> C_V <sub>DD</sub>		1.5	--	3.6	V
Low-Level Input Voltage	V <sub>IL</sub>		--	--	0.4	V
High-Level Input Voltage	V <sub>IH</sub>		1.3	--	--	V
Low-Level Output Voltage	V <sub>OL</sub>	Open-drain	--	--	0.4	V
Input Current Each IO Pin	I <sub>I</sub>	0.1V <sub>DD</sub> < V <sub>I</sub> < 0.9V <sub>DDMAX</sub>	-10	--	10	$\mu$ A
SCL Clock Frequency	f <sub>SCL</sub>		0	--	1000	kHz
Pulse width of spikes that must be suppressed by the input filter	t <sub>SP</sub>		--	--	50	ns
Data Hold Time	t <sub>HD:DAT</sub>		30	--	--	ns
Data Set-Up Time	t <sub>SU:DAT</sub>		70	--	--	ns

**Note 1.** Stresses beyond those listed “Absolute Maximum Ratings” may cause permanent damage to the device. These are stress ratings only, and functional operation of the device at these or any other conditions beyond those indicated in the operational sections of the specifications is not implied. Exposure to absolute maximum rating conditions may affect device reliability.

**Note 2.**  $\theta_{JA}$  is measured under natural convection (still air) at  $T_A = 25^\circ\text{C}$  with the component mounted on a high effective-thermal-conductivity four-layer test board on a JEDEC 51-7 thermal measurement standard.

**Note 3.** Devices are ESD sensitive. Handling precaution is recommended.

**Note 4.** The device is not guaranteed to function outside its operating conditions.

**Typical Application Circuit**

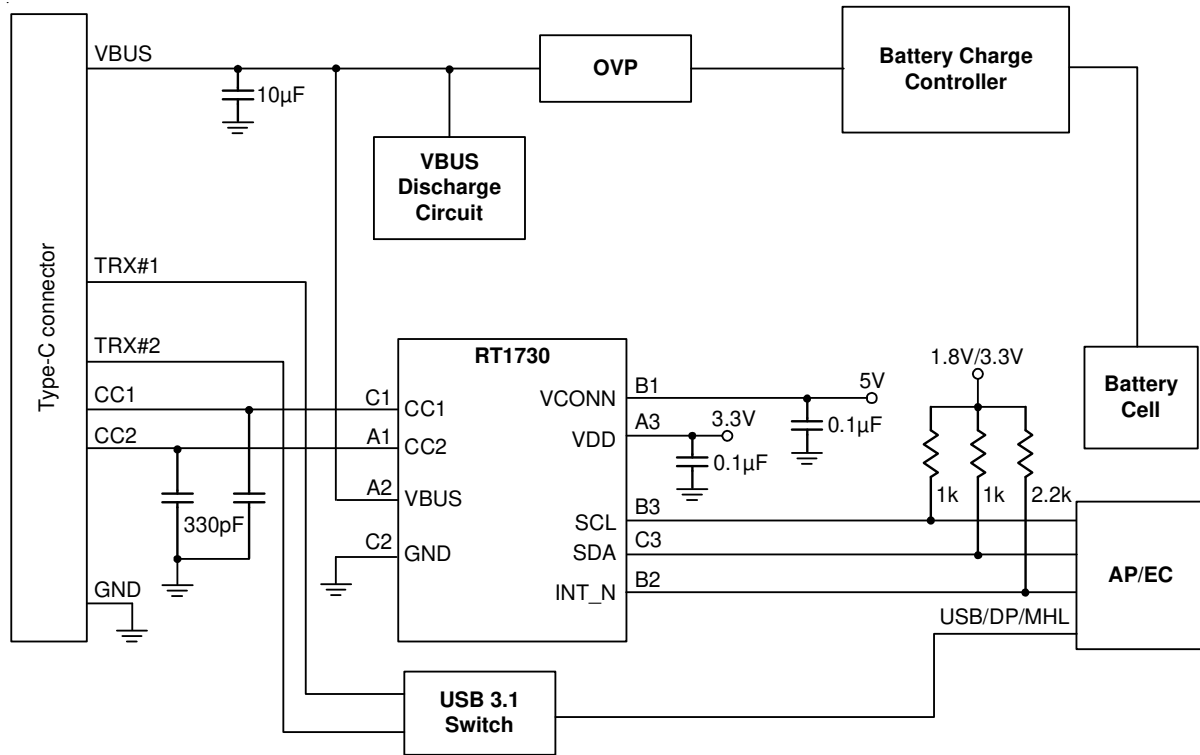

**Application Information**

**Abbreviations :**

Term	Description
TCPC	Type-C Port Controller
TCPCI	Type-C Port Controller Interface
TCPM	Type-C Port Manager

**Type-C Port Controller (TCPC) Interface :**

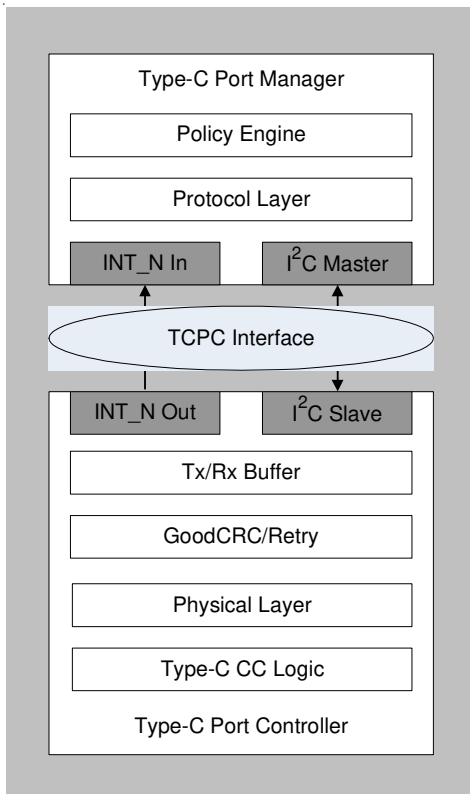

**The Controller Interface uses the I²C Protocol :**

- The TCPM is the only master on this I²C bus
- The TCPC is a slave device on this I²C bus
- Each Type-C port has its own unique I²C slave address. The TCPC shall have equal numbers of unique I²C slave addresses and supported Type-C ports
- The TCPC supports Fast-mode bus speed
- The TCPC has an open drain output, active low INT\_N Pin. This pin is used to indicate change of state, where INT\_N pin is asserted when any Alert Bits are set
- The TCPCI supports an I/O nominal voltage range of 1.8V and 3.3V
- The TCPC can auto-increment the I²C internal register address of the last byte transferred during a read independent of an ACK/NACK from the master
- The default I²C address shows below.

1	0	0	1	1	1	0	R/W
MSB							LSB

**Register Map :**

Addr	Length	RegName	Bit	BitName	Default	Type	Description
0x00	1	VENDOR_ID	7:0	VID[7:0]	0	R	A unique 16-bit unsigned integer. Assigned by the USB-IF to the Vendor.
0x01	1		7:0	VID[15:8]	0	R	
0x02	1	PRODUCT_ID	7:0	PID[7:0]	0	R	A unique 16-bit unsigned integer. Assigned uniquely by the Vendor to identify the TCPC.
0x03	1		7:0	PID[15:8]	0	R	
0x04	1	DEVICE_ID	7:0	DID[7:0]	0	R	A unique 16-bit unsigned integer. Assigned by the Vendor to identify the version of the TCPC.
0x05	1		7:0	DID[15:8]	0	R	
0x06	1	USBTYPEC_REV	7:0	USBTYPEC_REV	0	R	Version number assigned by USB-IF (Currently at Revision 1.1 – 0001 0001)
0x07	1		7:0	Reserved	0	R	
0x08	1	USBPD_REV_VER	7:0	USBPD_VER	0	R	0001 0000 – Version 1.0 0001 0001 – Version 1.1 Etc.
0x09	1		7:0	USBPD_REV	0	R	0010 0000 – Revision 2.0
0x0A	1	PD_INTERFACE_REV	7:0	PDIF_VER	0	R	0001 0000 – Version 1.0 0001 0001 – Version 1.1 Etc.
0x0B	1		7:0	PDIF_REV	0	R	0010 0000 – Revision 2.0
0x10	1	ALERT	1	POWER_STATUS	0	RW	0b : Cleared, 1b : Port status changed
			0	CC_STATUS	0	RW	0b : Cleared, 1b : CC status changed
0x11	1	ALERT	1	FAULT	0	RW	0b : No Fault. 1b : A Fault has occurred. Read the FAULT_STATUS register.
0x12	1	ALERT_MASK	1	M_POWER_STATUS	1	RW	0b : Interrupt masked, 1b : Interrupt unmasked
			0	M_CC_STATUS	1	RW	0b : Interrupt masked, 1b : Interrupt unmasked
0x13	1	ALERT_MASK	1	M_FAULT	1	RW	0b : Interrupt masked, 1b : Interrupt unmasked
0x14	1	POWER_STATUS_MASK	6	M_TCPC_INITIAL	1	RW	0b : Interrupt masked, 1b : Interrupt unmasked
			3	M_VBUS_PRESENT_DETC	1	RW	0b : Interrupt masked, 1b : Interrupt unmasked
			2	M_VBUS_PRESENT	1	RW	0b : Interrupt masked, 1b : Interrupt unmasked
			1	M_VCONN_PRESENT	1	RW	0b : Interrupt masked, 1b : Interrupt unmasked
0x15	1	FAULT_STATUS_MASK	7	M_VCON_OV	0	RW	0b : Interrupt masked, 1b : Interrupt unmasked
			1	M_VCON_OC	1	RW	0b : Interrupt masked, 1b : Interrupt unmasked

Addr	Length	RegName	Bit	BitName	Default	Type	Description
0x19	1	TGPC_CONTR OL	0	PLUG_ORIENT	0	RW	0b : When Vconn is enabled, apply it to the CC2 pin. Monitor the CC1 pin for BMC communications if PD messaging is enabled. 1b : When Vconn is enabled, apply it to the CC1 pin. Monitor the CC2 pin for BMC communications if PD messaging is enabled. Required
0x1A	1	ROLE_CONTR OL	7	Reserved	0	R	
			6	DRP	0	RW	0b : No DRP. Bits B3..0 determine Rp/Rd/Ra settings 1b : DRP
			5:4	RP_VALUE	0	RW	00b : Rp default 01b : Rp 1.5A 10b : Rp 3.0A 11b : Reserved
			3:2	CC2	10	RW	00b : Ra 01b : Rp (Use Rp definition in B5..4) 10b : Rd 11b : Open (dDisconnect or don't care) Set to 11b if enabling DRP in B7..6
			1:0	CC1	10	RW	00b : Ra 01b : Rp (Use Rp definition in B5..4) 10b : Rd 11b : Open (dDisconnect or don't care) Set to 11b if enabling DRP in B7..6
0x1B	1	FAULT_CONTR OL	7	DIS_VCON_OV	0	RW	0b : Fault detection circuit enabled 1b : Fault detection circuit disabled
			0	DIS_VCON_OC	0	RW	0b : Fault detection circuit enabled 1b : Fault detection circuit disabled



Addr	Length	RegName	Bit	BitName	Default	Type	Description
0x1C	1	POWER_CONTROL	1	VCONN_POWER_SPT	0	RW	0b : TCPC delivers at least 1W on VCONN 1b : TCPC delivers at least the power indicated in DEVICE_CAPABILITIES.VCONNPowerSupported
			0	EN_VCONN	0	RW	0b : Disable VCONN Source (default) 1b : Enable VCONN Source to CC Required
0x1D	1	CC_STATUS	7:6	Reserved	0	R	
			5	DRP_STATUS	0	R	0b : the TCPC has stopped toggling or (ROLE_CONTROL.DRP = 00) 1b : the TCPC is toggling
			4	DRP_RESULT	0	R	0b : the TCPC is presenting Rp 1b : the TCPC is presenting Rd
			3:2	CC2_STATUS	0	R	<p>If (ROLE_CONTROL.CC2 = Rp) or (DrpResult = 0) 00b : SRC.Open (Open, Rp) 01b : SRC.Ra (below maximum vRa) 10b : SRC.Rd (within the vRd range) 11b : reserved</p> <p>If (ROLE_CONTROL.CC2 = Rd) or (DrpResult = 1) 00b : SNK.Open (Below maximum vRa) 01b : SNK.Default (Above minimum vRd-Connect) 10b : SNK.Power1.5 (Above minimum vRd-Connect) Detects Rp 1.5A 11b : SNK.Power3.0 (Above minimum vRd-Connect) Detects Rp 3.0A</p> <p>If ROLE_CONTROL.CC2 = Ra, this field is set to 00b If ROLE_CONTROL.CC2 = Open, this field is set to 00b</p> <p>This field always returns 00b if (DrpStatus = 1) or (POWER_CONTROL.EnableVconn = 1 and POWER_CONTROL.PlugOrientation = 0). Otherwise, the returned value depends upon ROLE_CONTROL.CC2.</p>

Addr	Length	RegName	Bit	BitName	Default	Type	Description
0x1D	1	CC_STATUS	1:0	CC1_STATUS	0	R	<p>If (ROLE_CONTROL.CC1 = Rp) or (DrpResult = 0)</p> <p>00b : SRC.Open (Open, Rp)</p> <p>01b : SRC.Ra (below maximum vRa)</p> <p>10b : SRC.Rd (within the vRd range)</p> <p>11b : reserved</p> <p>If (ROLE_CONTROL.CC1 = Rd) or DrpResult = 1)</p> <p>00b : SNK.Open (Below maximum vRa)</p> <p>01b : SNK.Default (Above minimum vRd-Connect)</p> <p>10b : SNK.Power1.5 (Above minimum vRd-Connect) Detects Rp-1.5A</p> <p>11b : SNK.Power3.0 (Above minimum vRd-Connect) Detects Rp-3.0A</p> <p>If ROLE_CONTROL.CC1 = Ra, this field is set to 00b</p> <p>If ROLE_CONTROL.CC1 = Open, this field is set to 00b</p> <p>This field always returns 00b if (DrpStatus = 1) or (POWER_CONTROL.EnableVconn = 1 and POWER_CONTROL.PlugOrientation = 0). Otherwise, the returned value depends upon ROLE_CONTROL.CC1.</p>
0x1E	1	POWER_STATUS	6	TCPC_INITIAL	0	R	<p>0b : The TCPC has completed initialization and all registers are valid</p> <p>1b : The TCPC is still performing internal initialization and the only registers that are guaranteed to return the correct values are 00h..0Fh</p>
			3	VBUS_PRESENT_DETC	0	R	<p>0b : VBUS Present Detection Disabled</p> <p>1b : VBUS Present Detection Enabled (default)</p>
			2	VBUS_PRESENT	0	R	<p>0b : VBUS Disconnected</p> <p>1b : VBUS Connected</p>
			1	VCONN_PRESENT	0	R	<p>0b : VCONN is not present</p> <p>1b : This bit is asserted when VCONN present CC1 or CC2. Threshold is fixed at 2.4V</p>

Addr	Length	RegName	Bit	BitName	Default	Type	Description
0x1F	1	FAULT_STATU S	7	VCON_OV	0	RW	0b : Not in an over-voltage protection state 1b : Over-voltage fault latched.
			1	VCON_OC	0	RW	0b : No Fault detected 1b : Over-current VCONN fault latched
0x24	1	DEVICE_CAPA BILITIES_1L	7:5	ROLES_SUPPORT	110	R	000b : Type-C Port Manager can configure the Port as Source only or Sink only (not DRP) 001b : Source only 010b : Sink only 011b : Sink with accessory support (optional) 100b : DRP only 101b : Adapter or Cable (Ra) only 110b : Source, Sink, DRP, Adapter/Cable all supported 111b : Not valid
			4	ALL_SOP_SUPPORT	1	R	0b : All SOP* except SOP'_DBG/SOP''_DBG 1b : All SOP* messages are supported
			3	SOURCE_VCONN	1	R	0b : TCPC is not capable of switching VCONN 1b : TCPC is capable of switching VCONN
			2	CPB_SINK_VBUS	0	R	0b : TCPC is not capable controlling the sink path to the system load 1b : TCPC is capable of controlling the sink path to the system load
			1	SOURCE_HV_VBUS	0	R	0b : TCPC is not capable of controlling the source high voltage path to VBUS 1b : TCPC is capable of controlling the source high voltage path to VBUS
			0	SOURCE_VBUS	0	R	0b : TCPC is not capable of controlling the source path to VBUS 1b : TCPC is capable of controlling the source path to VBUS

Addr	Length	RegName	Bit	BitName	Default	Type	Description
0x25	1	DEVICE_CAPABILITIES_1H	7	Reserved	0	R	
			6	CPB_VBUS_OC	0	R	0b : VBUS OCP is not reported by the TCPC 1b : VBUS OCP is reported by the TCPC
			5	CPB_VBUS_OV	0	R	0b : VBUS OVP is not reported by the TCPC 1b : VBUS OVP is reported by the TCPC
			4	CPB_BLEED_DISC	0	R	0b : No Bleed Discharge implemented in TCPC 1b : Bleed Discharge is implemented in the TCPC
			3	CPB_FORCE_DISC	0	R	0b : No Force Discharge implemented in TCPC 1b : Force Discharge is implemented in the TCPC
			2	VBUS_MEASURE_ALARM	0	R	0b : No VBUS voltage measurement nor VBUS Alarms 1b : VBUS voltage measurement and VBUS Alarms
			1:0	SOURCE_RP_SUPPORT	10	R	00b : Rp default only 01b : Rp 1.5A and default 10b : Rp 3.0A, 1.5A, and default 11b : Reserved Rp values which may be configured by the TCPM via the ROLE_CONTROL register

Addr	Length	RegName	Bit	BitName	Default	Type	Description
0x26	1	DEVICE_CAPABILITIES_2L	7	SINK_DISCONNECT_DET	0	R	0b : VBUS_SINK_DISCONNECT_THRESHOLD not implemented (default : Use POWER_STATUS.VbusPresent = 0b to indicate a Sink disconnect) 1b : VBUS_SINK_DISCONNECT_THRESHOLD implemented
			6	STOP_DISC_THD	0	R	0b : VBUS_STOP_DISCHARGE_THRESHOLD not implemented (default) 1b : VBUS_STOP_DISCHARGE_THRESHOLD implemented
			5:4	VBUS_VOL_ALARM_LSB	11	R	00 : TCPC has 25mV LSB for its voltage alarm and uses all 10 bits in VBUS_VOLTAGE_ALARM_HI_CFG and VBUS_VOLTAGE_ALARM_LO_CFG. 01 : TCPC has 50mV LSB for its voltage alarm and uses only 9 bits. VBUS_VOLTAGE_ALARM_HI_CFG[0] and VBUS_VOLTAGE_ALARM_LO_CFG[0] are ignored by TCPC. 10 : TCPC has 100mV LSB for its voltage alarm and uses only 8 bits. VBUS_VOLTAGE_ALARM_HI_CFG[1:0] and VBUS_VOLTAGE_ALARM_LO_CFG[1:0] are ignored by TCPC. 11 : reserved
			3:1	VCONN_POWER	010	R	000b : 1.0W      100b : 4W 001b : 1.5W      101b : 5W 010b : 2.0W      110b : 6W 011b : 3W        111b : External
			0	VCONN_OCF	1	R	0b : TCPC is not capable of detecting a Vconn fault 1b : TCPC is capable of detecting a Vconn fault

Addr	Length	RegName	Bit	BitName	Default	Type	Description
0x27	1	DEVICE_CAPABILITIES_2H	7:0	Reserved	0	R	
0x28	1	STANDARD_INPUT_CAPABILITIES	7:3	Reserved	0	R	
			2	VBUS_EXT_OVF	0	R	0b : Not present in TCPC 1b : Present in TCPC
			1	VBUS_EXT_OCF	0	R	0b : Not present in TCPC 1b : Present in TCPC
			0	FORCE_OFF_VBUS_IN	0	R	0b : Not present in TCPC 1b : Present in TCPC
0x29	1	STANDARD_OUTPUT_CAPABILITIES	7	Reserved	0	R	
			6	CPB_DBG_ACC_IND	0	R	0b : Not present in TCPC 1b : Present in TCPC
			5	CPB_VBUS_PRESENT_MNT	0	R	0b : Not present in TCPC 1b : Present in TCPC
			4	CPB_AUDIO_ADT_ACC_IND	0	R	0b : Not present in TCPC 1b : Present in TCPC
			3	CPB_ACTIVE_CABLE_IND	0	R	0b : Not present in TCPC 1b : Present in TCPC
			2	CPB_MUX_CFG_CTRL	0	R	0b : Not present in TCPC 1b : Present in TCPC
			1	CPB_CONNECT_PRESENT	0	R	0b : Not present in TCPC 1b : Present in TCPC
			0	CPB_CONNECT_ORIENT	0	R	0b : Not present in TCPC 1b : Present in TCPC

**Thermal Considerations**

The junction temperature should never exceed the absolute maximum junction temperature  $T_{J(MAX)}$ , listed under Absolute Maximum Ratings, to avoid permanent damage to the device. The maximum allowable power dissipation depends on the thermal resistance of the IC package, the PCB layout, the rate of surrounding airflow, and the difference between the junction and ambient temperatures. The maximum power dissipation can be calculated using the following formula :

$$P_{D(MAX)} = (T_{J(MAX)} - T_A) / \theta_{JA}$$

where  $T_{J(MAX)}$  is the maximum junction temperature,  $T_A$  is the ambient temperature, and  $\theta_{JA}$  is the junction-to-ambient thermal resistance.

For continuous operation, the maximum operating junction temperature indicated under Recommended Operating Conditions is 125°C. The junction-to-ambient thermal resistance,  $\theta_{JA}$ , is highly package dependent. For a WL-CSP-9B 1.38x1.34 (BSC) package, the thermal resistance,  $\theta_{JA}$ , is 81.5°C/W on a standard JEDEC 51-7 high effective-thermal-conductivity four-layer test board. The maximum power dissipation at  $T_A = 25^\circ\text{C}$  can be calculated as below :

$$P_{D(MAX)} = (125^\circ\text{C} - 25^\circ\text{C}) / (81.5^\circ\text{C/W}) = 1.22\text{W for a WL-CSP-9B 1.38x1.34 (BSC) package.}$$

The maximum power dissipation depends on the operating ambient temperature for the fixed  $T_{J(MAX)}$  and the thermal resistance,  $\theta_{JA}$ . The derating curves in Figure 1 allows the designer to see the effect of rising ambient temperature on the maximum power dissipation.

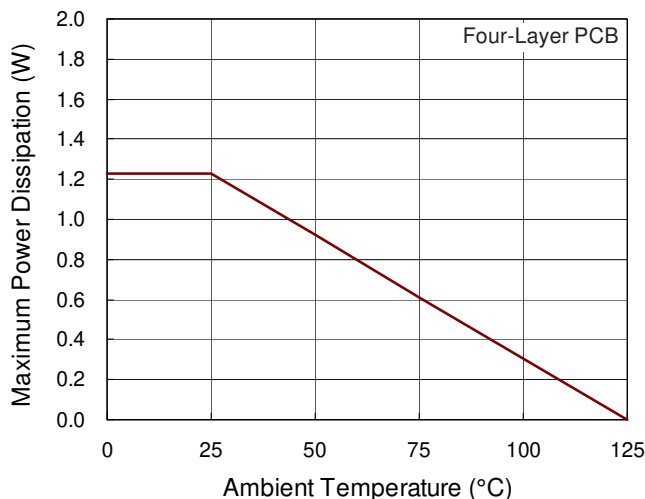
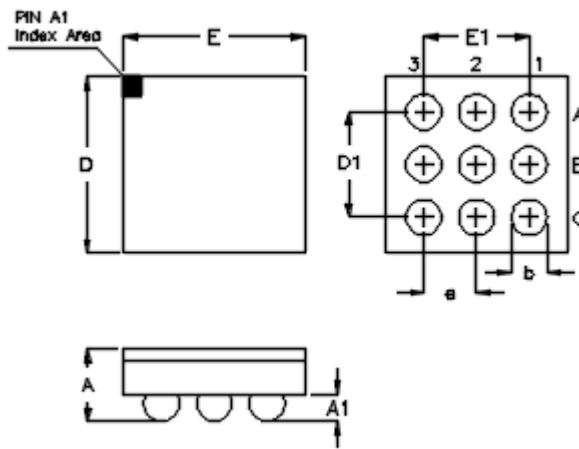

Figure 1. Derating Curve of Maximum Power Dissipation

Outline Dimension



Symbol	Dimensions In Millimeters		Dimensions In Inches	
	Min	Max	Min	Max
A	0.500	0.600	0.020	0.024
A1	0.170	0.230	0.007	0.009
b	0.240	0.300	0.009	0.012
D	1.300	1.380	0.051	0.054
D1	0.800		0.031	
E	1.340	1.420	0.053	0.056
E1	0.800		0.031	
e	0.400		0.016	

9B WL-CSP 1.38x1.34 Package (BSC)



**Footprint Information**

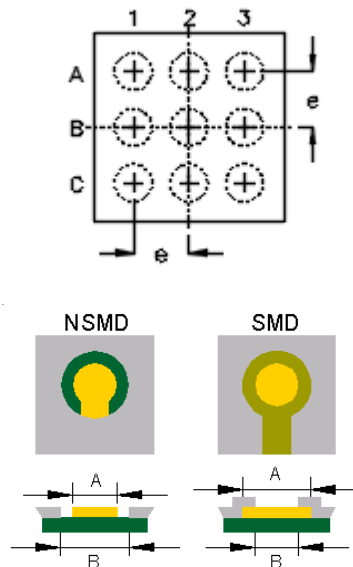

Package	Number of Pin	Type	Footprint Dimension (mm)			Tolerance
			e	A	B	
WL-CSP1.38*1.34-9(BSC)	9	NSMD	0.400	0.240	0.340	±0.025
		SMD		0.270	0.240	

**Richtek Technology Corporation**

14F, No. 8, Tai Yuen 1<sup>st</sup> Street, Chupei City  
 Hsinchu, Taiwan, R.O.C.  
 Tel: (8863)5526789

Richtek products are sold by description only. Richtek reserves the right to change the circuitry and/or specifications without notice at any time. Customers should obtain the latest relevant information and data sheets before placing orders and should verify that such information is current and complete. Richtek cannot assume responsibility for use of any circuitry other than circuitry entirely embodied in a Richtek product. Information furnished by Richtek is believed to be accurate and reliable. However, no responsibility is assumed by Richtek or its subsidiaries for its use; nor for any infringements of patents or other rights of third parties which may result from its use. No license is granted by implication or otherwise under any patent or patent rights of Richtek or its subsidiaries.