

Features

- Output current: 1 A per channel
- Shorted-load protection
- Junction overtemperature protection
- Case overtemperature protection for thermal independence of the channels
- Non-simultaneous TCSD (thermal case shutdown) restart for the various channels
- Protection against loss of ground
- Current limitation
- Undervoltage shutdown
- Open load in off-state and short to V_{CC} detection
- Open-drain diagnostic outputs
- 3.3 V CMOS/TTL compatible inputs
- Fast demagnetization of inductive loads
- Conforms to IEC 61131-2 supply voltage: +4 V to +36 V
- RoHS compliant

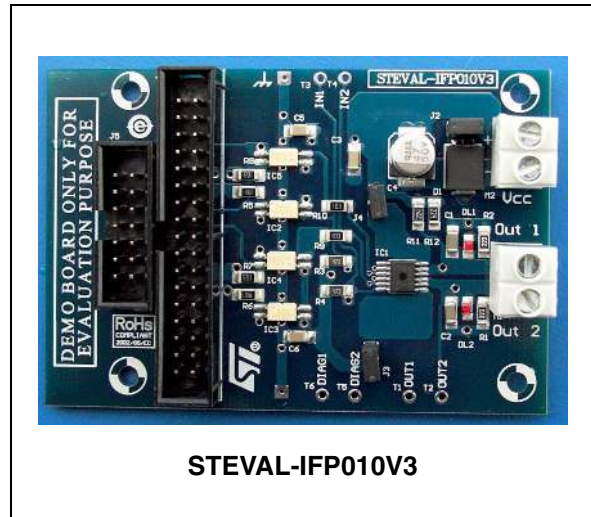

If more than one channel is in overload, the TCSD restart will not be simultaneous in order to prevent high peak current from the supply. Non-overloaded channels continue to operate normally. The open-drain diagnostic outputs indicate overtemperature conditions and open load in the off-state.

Description

The STEVAL-IFP010V3 demonstration board is based on the VNI2140J, a monolithic device designed using ST's VIPower technology for driving two independent resistive or inductive loads with one side connected to ground. Active current limitation prevents a drop in system power supply if the load is shorted. A built-in thermal shutdown protects the chip from overtemperature and short-circuit conditions. During an overload condition, the channel turns off and back on automatically in order to maintain the junction temperature between TTSD and TR. If this condition causes the case temperature to reach TCSD, the overloaded channel is turned off and will restart only when the case temperature has decreased down to TCR.

1 Schematic circuit

Figure 1. Schematic circuit

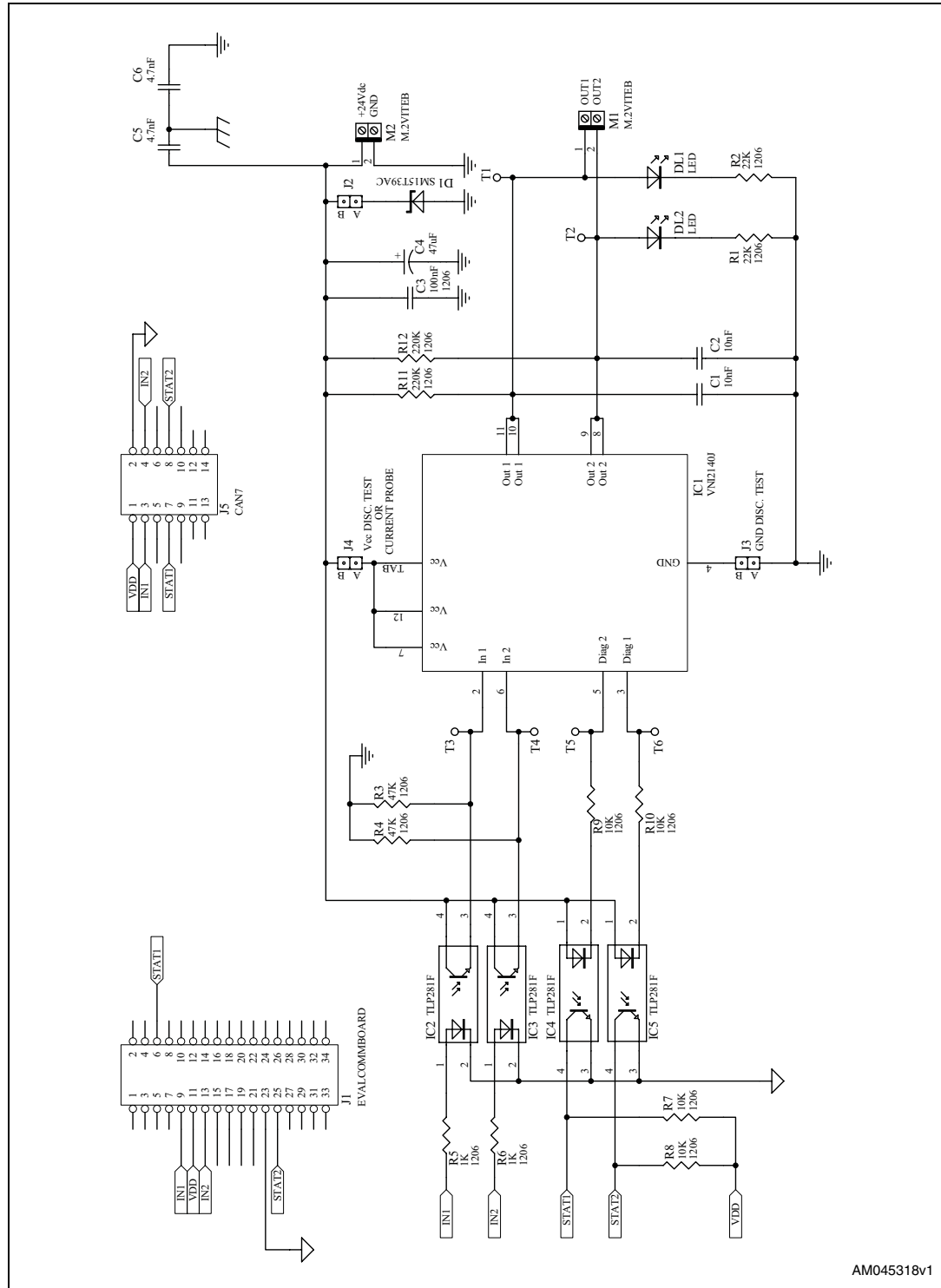

AM045318v1

2 Revision history

Table 1. Document revision history

Date	Revision	Changes
22-Dec-2011	1	Initial release.

Please Read Carefully:

Information in this document is provided solely in connection with ST products. STMicroelectronics NV and its subsidiaries ("ST") reserve the right to make changes, corrections, modifications or improvements, to this document, and the products and services described herein at any time, without notice.

All ST products are sold pursuant to ST's terms and conditions of sale.

Purchasers are solely responsible for the choice, selection and use of the ST products and services described herein, and ST assumes no liability whatsoever relating to the choice, selection or use of the ST products and services described herein.

No license, express or implied, by estoppel or otherwise, to any intellectual property rights is granted under this document. If any part of this document refers to any third party products or services it shall not be deemed a license grant by ST for the use of such third party products or services, or any intellectual property contained therein or considered as a warranty covering the use in any manner whatsoever of such third party products or services or any intellectual property contained therein.

UNLESS OTHERWISE SET FORTH IN ST'S TERMS AND CONDITIONS OF SALE ST DISCLAIMS ANY EXPRESS OR IMPLIED WARRANTY WITH RESPECT TO THE USE AND/OR SALE OF ST PRODUCTS INCLUDING WITHOUT LIMITATION IMPLIED WARRANTIES OF MERCHANTABILITY, FITNESS FOR A PARTICULAR PURPOSE (AND THEIR EQUIVALENTS UNDER THE LAWS OF ANY JURISDICTION), OR INFRINGEMENT OF ANY PATENT, COPYRIGHT OR OTHER INTELLECTUAL PROPERTY RIGHT.

UNLESS EXPRESSLY APPROVED IN WRITING BY TWO AUTHORIZED ST REPRESENTATIVES, ST PRODUCTS ARE NOT RECOMMENDED, AUTHORIZED OR WARRANTED FOR USE IN MILITARY, AIR CRAFT, SPACE, LIFE SAVING, OR LIFE SUSTAINING APPLICATIONS, NOR IN PRODUCTS OR SYSTEMS WHERE FAILURE OR MALFUNCTION MAY RESULT IN PERSONAL INJURY, DEATH, OR SEVERE PROPERTY OR ENVIRONMENTAL DAMAGE. ST PRODUCTS WHICH ARE NOT SPECIFIED AS "AUTOMOTIVE GRADE" MAY ONLY BE USED IN AUTOMOTIVE APPLICATIONS AT USER'S OWN RISK.

Resale of ST products with provisions different from the statements and/or technical features set forth in this document shall immediately void any warranty granted by ST for the ST product or service described herein and shall not create or extend in any manner whatsoever, any liability of ST.

ST and the ST logo are trademarks or registered trademarks of ST in various countries.

Information in this document supersedes and replaces all information previously supplied.

The ST logo is a registered trademark of STMicroelectronics. All other names are the property of their respective owners.

© 2011 STMicroelectronics - All rights reserved

STMicroelectronics group of companies

Australia - Belgium - Brazil - Canada - China - Czech Republic - Finland - France - Germany - Hong Kong - India - Israel - Italy - Japan - Malaysia - Malta - Morocco - Philippines - Singapore - Spain - Sweden - Switzerland - United Kingdom - United States of America

www.st.com