

General Description

The SY84402L is a 3.3V VCSEL driver for applications up to 4.25Gbps. The driver comes in a 2mm x 2mm MLF[®] package which makes it less than half the size of any other driver operating at that rate. The variable output swing on the SY84402L makes it ideal for use as a VCSEL driver as well as a backplane driver/receiver.

The operational range of the SY84402L control input is from $V_{CC}-1.42V$ (for maximum output swing) to V_{CC} (for minimum output swing). VCTRL can also be driven by a DAC such as those contained in the MIC300X, Micrel's FOM controller family.

The SY84402L provides a VT output for use as a DC bias for AC-coupling to the device. The input termination network can easily be modified to handle a DC-coupled PECL output to save board space by simply tying the VT terminal to ground through a 50 Ohm resistor. The VT pin should be used only as a bias for this device as its current sink/source capability is limited.

All datasheets and support documentation can be found on Micrel's web site at: www.micrel.com.

Features

- 3.3V power supply
- Operates from 100Mbps up to 4.25Gbps
- 100k-compatible PECL/ECL I/O
- Guaranteed operation over $-40^{\circ}C$ to $+85^{\circ}C$ temperature range
- Fully controllable with Micrel MIC300X controller
- Available in ultra-small 10-pin MLF[®] (2mm x 2mm) package

Applications

- Multirate LAN, SAN applications up to 4.25Gbps: Ethernet, GbE, FC
- SFF, SFP Modules
- Backplane receiver

Typical Application

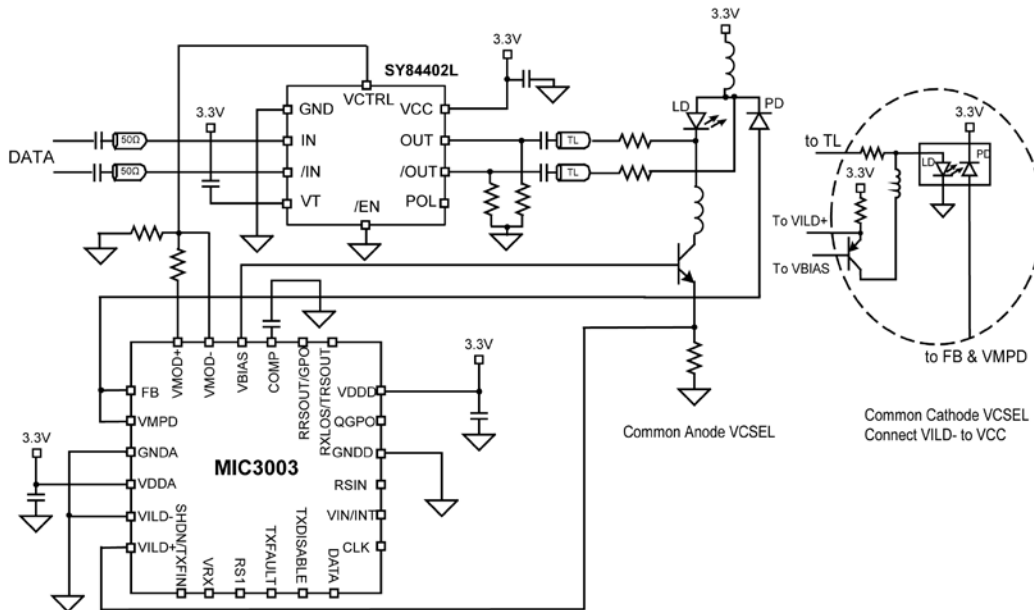

MicroLeadFrame and MLF are registered trademarks of Amkor Technology, Inc.

Micrel Inc. • 2180 Fortune Drive • San Jose, CA 95131 • USA • tel +1 (408) 944-0800 • fax +1 (408) 474-1000 • <http://www.micrel.com>

Ordering Information

Part Number	Package Type	Operating Range	Package Marking	Lead Finish
SY84402LMGTR ⁽¹⁾	MLF-10	Industrial	402L with Pb-Free bar-line indicator	Pb-Free NiPdAu

Note:

- Pb-Free package is recommended for new designs.

Pin Configuration

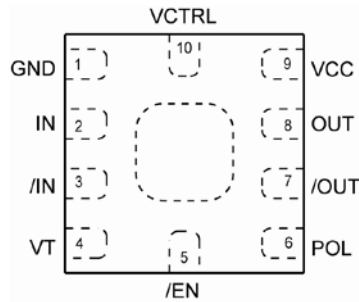

10-Pin MLF[®] (2mm x 2mm) (MLF-10)

Pin Description

Pin Number	Pin Name	Pin Function
1	GND Exposed Pad	GND and Exposed pad must be tied to most negative supply. For LVPECL connect to ground.
2, 3	IN, /IN	Differential input. Both pins are internally terminated with 50 Ω to VT. Refer to "Interface driver input to different logic drivers" section for more details.
4	VT	Reference Voltage. Refer to "Interface driver input to different logic drivers" section for proper termination.
5	/EN	Active Low TTL. The driver is enabled when this pin is unconnected or /EN asserted low. The driver is disabled when /EN is asserted high. Pulled down internally with 75k Ω resistor. The polarity of the output in disabled state is inverted when POL is exerted high. Refer to the truth table for details.
6	POL	TTL input, Pulled down internally with 75k Ω resistor. Asserting this pin high will invert output polarity of the input data. If this pin is asserted low or left open, the polarity is kept unchanged. Refer to the truth table for more details.
8, 7	OUT, /OUT	Differential Outputs: Variable swing PECL output pair defaults to undetermined state if inputs left open. See "Typical application" section for recommendations on terminations.
9	VCC	Positive Power Supply: Bypass with 0.1 μ F//0.01 μ F low ESR capacitors.
10	VCTRL	Control Voltage Input: Variable voltage input to control output swings with VCTRL = VCC for minimum swing and VCTRL = VCC-1.42V for maximum swing

Truth Table

IN	/IN	/EN	POL	OUT	/OUT
H	L	L	L	H	L
L	H	L	L	L	H
H	L	L	H	L	H
L	H	L	H	H	L
X	X	H	L	L	H
X	X	H	H	H	L

H: High L: Low X: Don't care

Absolute Maximum Ratings⁽¹⁾

Supply Voltage (V_{CC})	-0.5V to +4.0V
Input Voltage (V_{IN})	-0.5V to V_{CC}
LVPECL Output Current (I_{OUT})		
Continuous	50mA
Surge	100mA
Input Current		
Source or sink current on IN, /IN	± 50 mA
Lead Temperature (soldering, 20 sec.)	+260°C
Storage Temperature (T_S)	-65°C to +150°C

Operating Ratings⁽²⁾

Supply Voltage ($ V_{CC}-GND $)	3.0V to 3.6V
Ambient Temperature (T_A)	-40°C to +85°C
Package Thermal Resistance ⁽³⁾		
MLF [®] (θ_{JA})		
Still-Air	93°C/W
500lfpm	87°C/W
MLF [®] (Ψ_{JB})		
Junction-to-Board	32°C/W

DC Electrical Characteristics⁽⁴⁾

$V_{CC} = +3.3V \pm 10\%$, $T_A = -40^\circ\text{C}$ to $+85^\circ\text{C}$, and $R_L = 50\Omega$ to $V_{CC} - 2V$ unless otherwise noted.

Symbol	Parameter	Condition	Min	Typ	Max	Units
I_{CC}	Power Supply Current	Max V_{CC} , no load			50	mA
V_{OH}	Output HIGH Voltage		$V_{CC} - 1.145$	$V_{CC} - 1.020$	$V_{CC} - 0.895$	V
V_{OL}	Output LOW Voltage	$V_{CTRL} = V_{CC} - 1.42V$	$V_{CC} - 1.945$	$V_{CC} - 1.820$	$V_{CC} - 1.695$	V
V_{OPP}	Output swing	$V_{CTRL} = V_{CC} - 1.42V$		800		mV
		$V_{CTRL} = V_{CC}$		100		mV
V_{IH}	Input HIGH Voltage		$V_{CC} - 1.165$		$V_{CC} - 0.880$	V
V_{IL}	Input LOW Voltage		$V_{CC} - 1.945$		$V_{CC} - 1.625$	V
V_{IN}	Input Voltage Swing	Single ended	100		1700	mV _{PP}
$R_{IN(DATA)}$	Input Resistance at IN, /IN, Single Ended		45	50	55	Ω
VT	Reference Voltage			$V_{CC} - 1.32$		V
VCMR	Common Mode Range	Note 5	$V_{CC} - 1.3$		V_{CC}	V
V_{CTRL}	Output swing control voltage		$V_{CC} - 1.42$		V_{CC}	V

Notes:

1. Exceeding the absolute maximum rating may damage the device.
2. The device is not guaranteed to function outside its operating rating.
3. Package Thermal Resistance assumes exposed pad is soldered (or equivalent) to the devices most negative potential on the PCB. θ_{JB} uses a 4-layer and θ_{JA} in still air unless otherwise stated.
4. Specification for packaged product only.
5. The CMR range is referenced to the most positive side of the differential input signal. Normal operation is obtained if the HIGH level falls within the specified range and the peak-to-peak voltage lies between V_{PP} (min.) and 1V.

AC Electrical Characteristics

$V_{CC} = +3.3V \pm 10\%$ and $GND = 0V$; $T_A = -40^\circ C$ to $+85^\circ C$, $R_L = 50\Omega$ to $V_{CC} - 2V$ unless otherwise noted.

Symbol	Parameter	Condition	Min	Typ	Max	Units
	Maximum Data Rate	NRZ Data	4.25			Gbps
t_r, t_f	Output Rise/Fall Times (20% to 80%)	OUT, /OUT, Note 6	30	60	80	ps

Notes:

6. Output with $V_{CTRL} = V_{CC} - 1.42V$.

Typical Characteristics

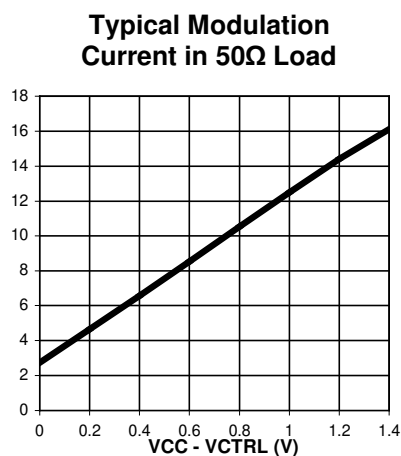
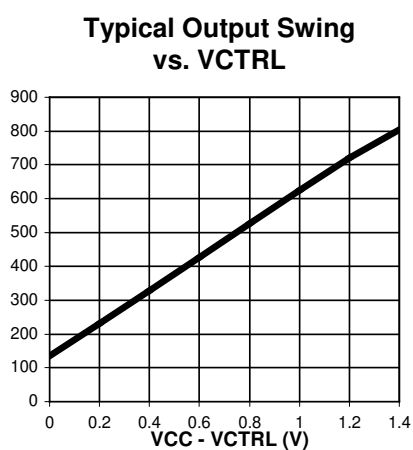

Functional Characteristics

**Electrical Eye Diagram
at 4.25Gbps, PRBS 2⁷-1, R_L = 50Ω**

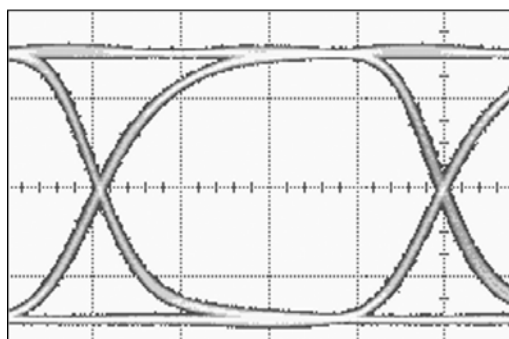

Functional Block Diagram

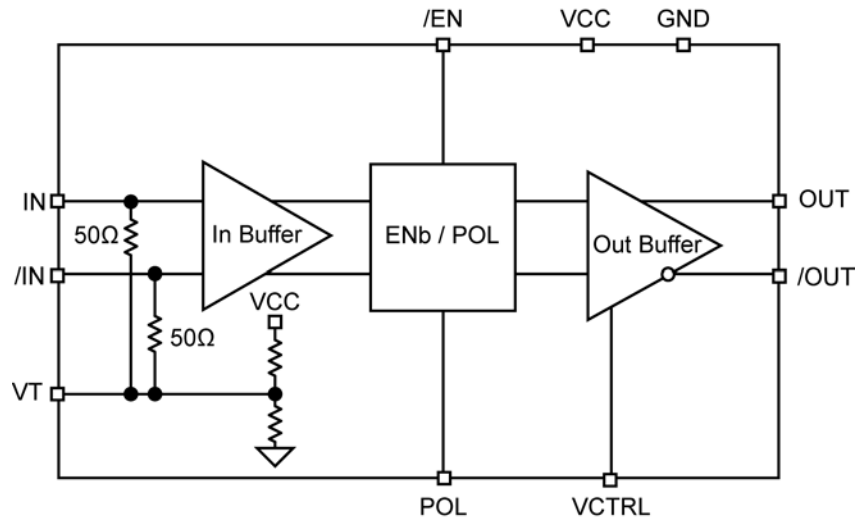

Functional Description

As shown on the block diagram above, the driver is composed from an input buffer, Enable and polarity block, and output buffer. In order to accommodate VCSELs with different polarity and keep the data non inverted, the input data polarity can be inverted by setting pin 6 (POL) high. The modulation current into the VCSEL is determined by the ratio between the output

voltage swing and the total load including VCSEL's equivalent resistance and any damping series resistor. The output signal amplitude is determined by the voltage applied at pin 10 (VCTRL) which should be within the range of $VCC - 1.42$ to VCC .

Input and Output Stages

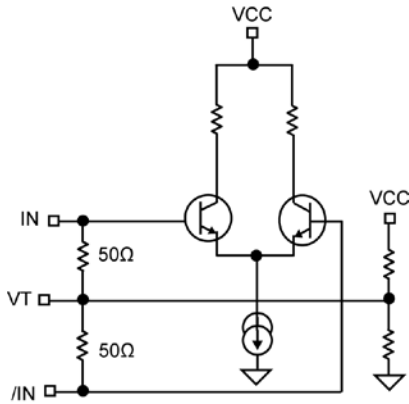

Figure 1a. Simplified Driver Input Stage

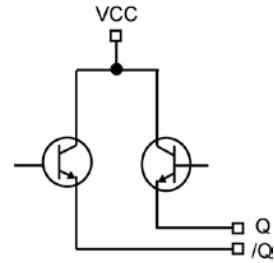

Figure 1b. Simplified Driver Output Stage

Interfacing Driver Input to Different Logic Drivers

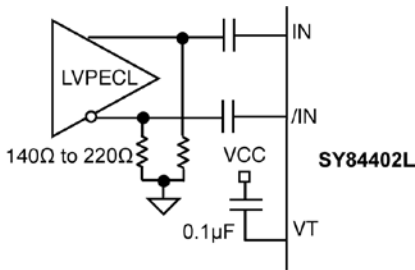

Figure 2a. AC-Coupled Input to LVPECL

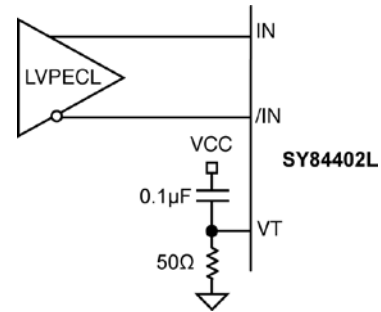

Figure 2b. DC-Coupled Input to LVPECL

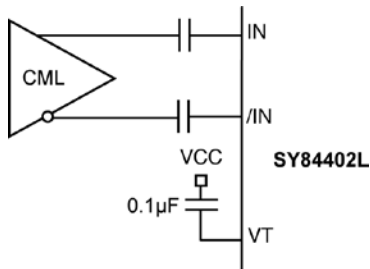

Figure 2c. AC-Coupled Input to CML

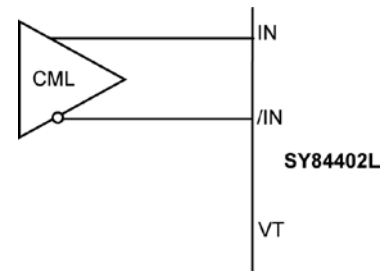
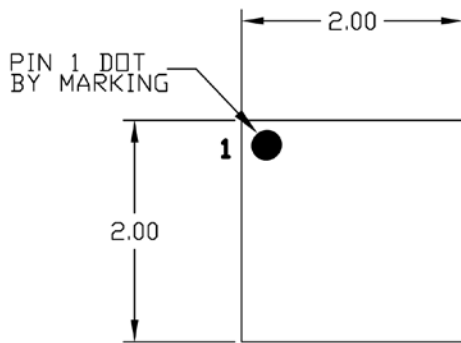
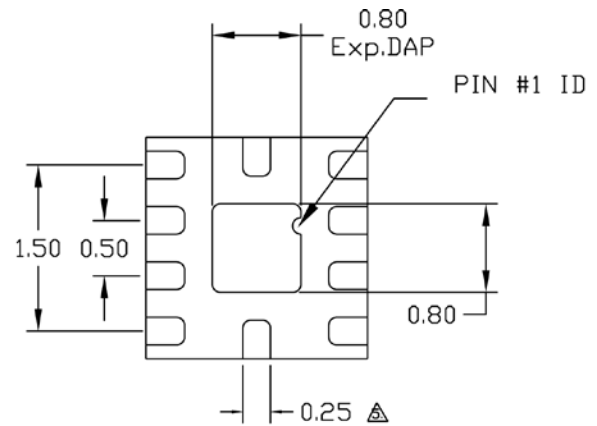

Figure 2d. DC-Coupled Input to CML

Package Information



TOP VIEW



BOTTOM VIEW

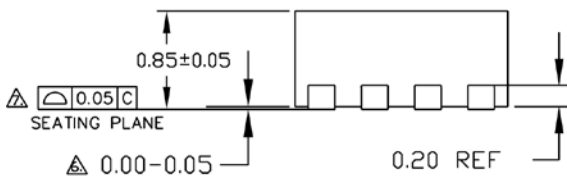

SIDE VIEW

NOTE:

1. ALL DIMENSIONS ARE IN MILLIMETERS.
 2. MAX. PACKAGE WARPAGE IS 0.05 mm.
 3. MAXIMUM ALLOWABLE BURRS IS 0.076 mm IN ALL DIRECTIONS.
 4. PIN #1 ID ON TOP WILL BE LASER/INK MARKED.
- ⚠ DIMENSION APPLIES TO METALIZED TERMINAL AND IS MEASURED BETWEEN 0.20 AND 0.25 mm FROM TERMINAL TIP.
- ⚠ APPLIED ONLY FOR TERMINALS.
- ⚠ APPLIED FOR EXPOSED PAD AND TERMINALS.

10-Pin EPAD *MicroLeadFrame*[®] (MLF-10)

Package Notes:

1. Package meets Level 2 qualification.
2. All parts are dry-packaged before shipment.
3. Exposed pads must be soldered to a plane equivalent to device GND for proper thermal management.

MICREL, INC. 2180 FORTUNE DRIVE SAN JOSE, CA 95131 USA
 TEL +1 (408) 944-0800 FAX +1 (408) 474-1000 WEB <http://www.micrel.com>

The information furnished by Micrel in this data sheet is believed to be accurate and reliable. However, no responsibility is assumed by Micrel for its use. Micrel reserves the right to change circuitry and specifications at any time without notification to the customer.

Micrel Products are not designed or authorized for use as components in life support appliances, devices or systems where malfunction of a product can reasonably be expected to result in personal injury. Life support devices or systems are devices or systems that (a) are intended for surgical implant into the body or (b) support or sustain life, and whose failure to perform can be reasonably expected to result in a significant injury to the user. A Purchaser's use or sale of Micrel Products for use in life support appliances, devices or systems is a Purchaser's own risk and Purchaser agrees to fully indemnify Micrel for any damages resulting from such use or sale.

© 2009 Micrel, Incorporated.