



Am686

Voltage Comparators

Advanced
Micro
Devices

DISTINCTIVE CHARACTERISTICS

- 12 ns Maximum Propagation Delay at 5 mV Overdrive
- Complementary Schottky TTL Outputs
- Fanout of 5

FUNCTIONAL DESCRIPTION

The Am686 is a fast voltage comparator manufactured with an advanced bipolar NPN, Schottky-diode high-frequency process that ensures very short propagation delays without sacrificing the excellent matching characteristics hitherto associated only with slow, high-performance linear ICs. The circuit has differential analog inputs and complementary logic outputs compatible with Schottky TTL. The output-current capability is adequate for driving five standard Schottky inputs. The low input offset and high resolution make this comparator

especially suitable for high-speed precision analog-to-digital processing.

A latch function is provided so that the comparator can be used in a sample-hold mode. If the Latch Enable input is LOW, the comparator functions normally. When the Latch Enable is driven HIGH, the comparator outputs are locked in their existing logic states. If the latch function is not used, the Latch Enable may be left open or connected to ground.

CIRCUIT DIAGRAM

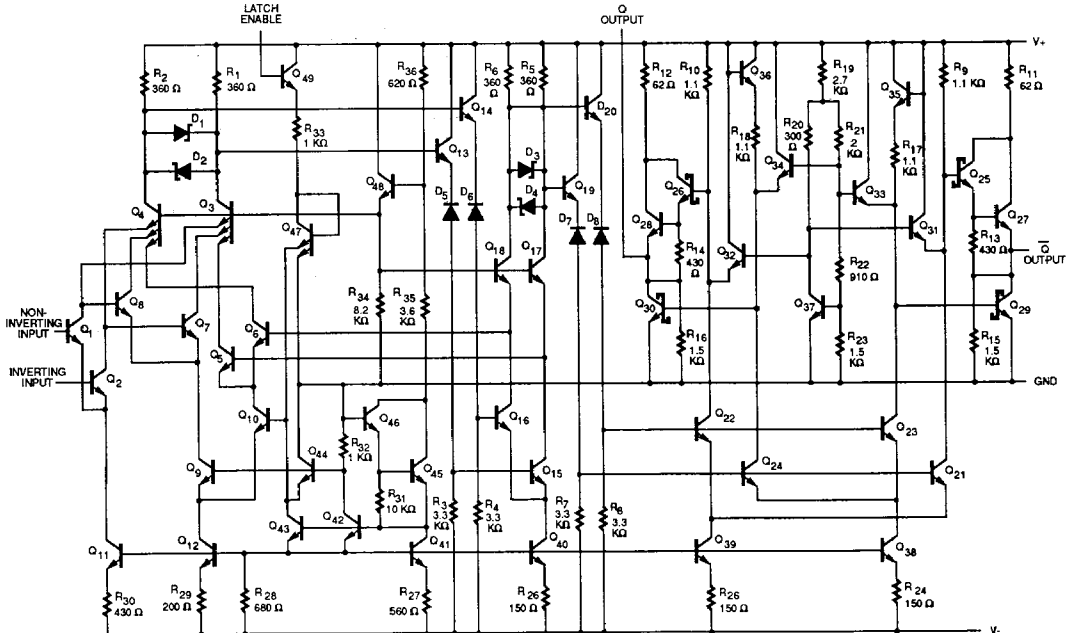

03938-001

CONNECTION DIAGRAM

Top View

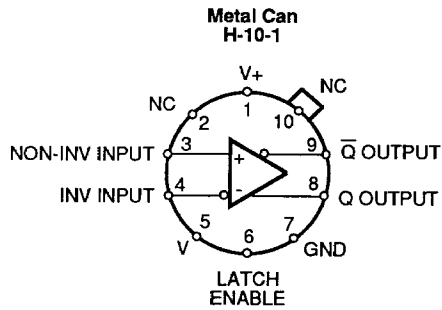

03938-002

Note: On metal package, pin 5 is connected to case. On DIP, pin 6 is connected to case.

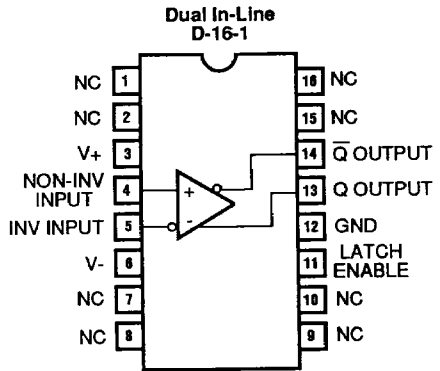

03938-004

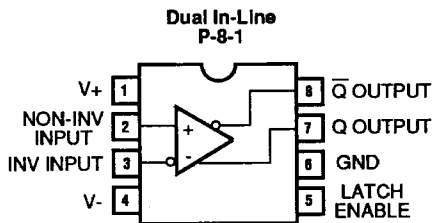

03938-003

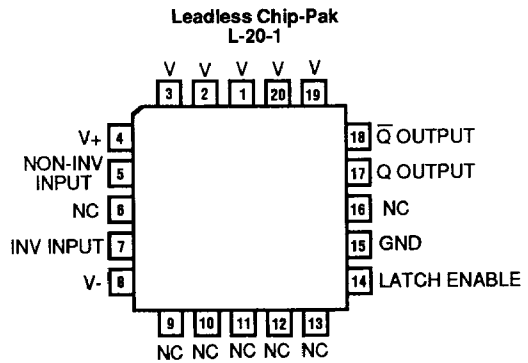

03938-005

ORDERING INFORMATION

Standard Products

AMD standard products are available in several packages and operating ranges. The ordering number (Valid Combination) is formed by a combination of:

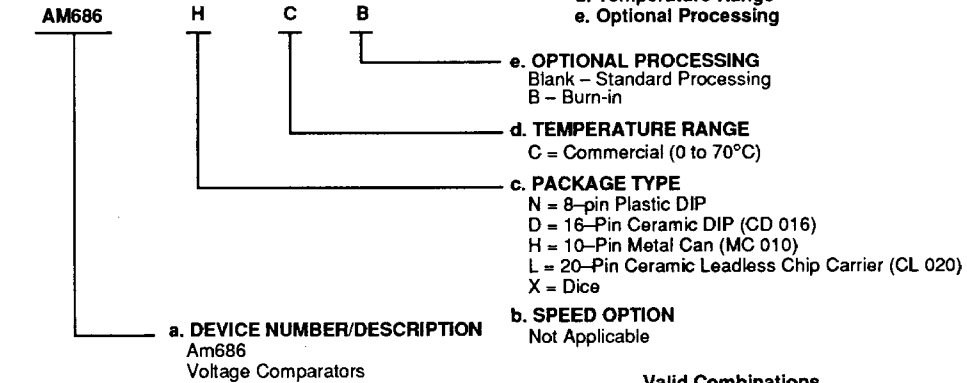

Valid Combinations	
AM686	HC, DC, CN, CN-1, XC, XM, LMB

Valid Combinations

Valid Combinations list configurations planned to be supported in volume for this device. Consult the local AMD sales office to confirm availability of specific valid combinations, to check on newly released combinations, and to obtain additional data on AMD's standard military grade products.

MILITARY ORDERING INFORMATION

APL Products

AMD products for Aerospace and Defense applications are available in several packages and operating ranges. APL (Approved Products List) products are fully compliant with MIL-M-38510 and MIL-STD-883C requirements. CPL (Controlled Products List) products are processed in accordance with MIL-STD-883C, but are inherently non-compliant because of package, solderability, or surface treatment exceptions to those specifications. The order number (Valid Combination) for APL products is formed by a combination of:

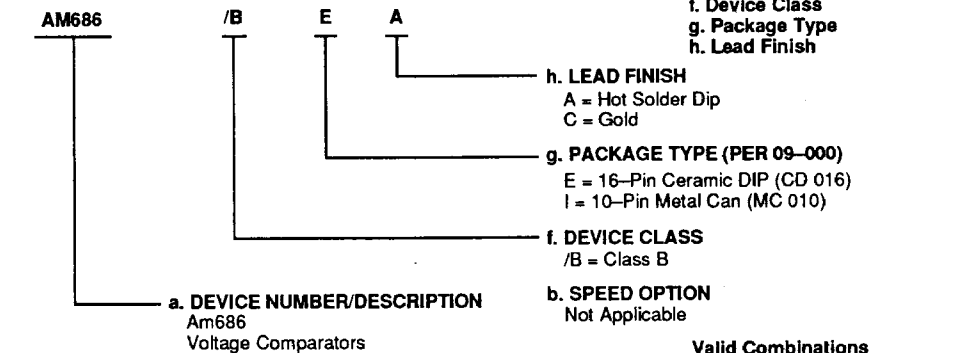

Valid Combinations	
AM686	/BEA /BIC

Valid Combinations

Valid Combinations list configurations planned to be supported in volume for this device. Consult the local AMD sales office to confirm availability of specific valid combinations, to check on newly released combinations.

Group A Tests

Group A Tests consist of sub-groups 1, 2, 3, 4, 5, 6, 9

MAXIMUM RATINGS

Positive Supply Voltage	+7 V
Negative Supply Voltage	-7 V
Input Voltage	±4 V
Differential Input Voltage	±6 V
Power Dissipation (Note 1)	600 mW
Lead Temperature (Soldering, 60 sec.)	300°C
Storage Temperature Range	-65°C to +150°C

OPERATING RANGES

Am686C and Am686C-1*	0°C to +70°C
Am686 Military	-55°C to +125°C
Operating Supply Voltage Range	
Am686C and Am686C-1	V+ = +5.0 V ±5%, V- = -6.0 V ±5%
Am686 Military	V+ = +5.0 V ±10%, V- = -6.0 V ±10%
Minimum Operating Voltage (V* to V-)	9.7 V

Stresses above those listed under ABSOLUTE MAXIMUM RATINGS may cause permanent device failure. Functionality at or above these limits is not implied. Exposure to absolute maximum ratings for extended periods may affect device reliability.

* To duplicate high power steady state operation, parts are pulse tested at these correlated temperatures: 686C = -10°C to +100°C, 686M = -35°C to +150°C

Operating ranges define those limits between which the functionality of the device is guaranteed.

ELECTRICAL CHARACTERISTICS

Over the operating temperature ranges (unless otherwise specified)

DC Characteristics (Included in Group A, Subgroup 1,2,3,4,5,6, unless noted)

Parameter Symbol	Parameter Description	Test Conditions (Note 2)	COM'L		MIL		Unit
			Min.	Max.	Min.	Max.	
V _{OS}	Input Offset Voltage	R _S = 100 Ω, T _A = 25°C R _S = 100 Ω CN-1		3.0 3.5 6.0 10.0		2.0 3.0	mV mV
ΔV _{OS} /ΔT	Average Temperature Coefficient of Input Offset Voltage	R _S = 100 Ω (Note 4)		10		10	μV/°C
I _{OS}	Input Offset Current	25°C ≤ T _A ≤ T _A (max) T _A = T _A (min)		1.0 1.3		1.0 1.6	μA μA
I _B	Input Bias Current	25°C ≤ T _A ≤ T _A (max) T _A = 25°C		10 13		10 16	μA μA
V _{CM}	Input Voltage Range		-3.3	+2.7	-3.3	+2.7	V
CMMR	Common Mode Rejection Ratio	R _S = 100 Ω, -3.3 V < V _{CM} < +2.7 V	80		80		dB
SVRR	Supply Voltage Rejection Ratio	R _S = 100 Ω	60		60		dB
V _{OH}	Output HIGH Voltage	I _L = -1.0 mA, V _S = V _S (min)	2.7		2.5		V
V _{OL}	Output LOW Voltage	I _L = 10 mA, V _S = V _S (max)		0.5		0.5	V
I ₊	Positive Supply Current			42		40	mA
I ₋	Negative Supply Current			34		32	mA
P _{DISS}	Power Dissipation			415		400	mW

**Switching Characteristics ($V_+ = +5.0\text{ V}$, $V_- = -6.0\text{ V}$, $V_{IN} = 100\text{ mV}$, $V_{OD} = 5.0\text{ mV}$, $C_L = 15\text{ pF}$) (Note 3)
Included in Group A Subgroup 9 unless noted.**

Parameter Symbol	Parameter Description	Test Conditions	COM'L		MIL		Unit
			Min.	Max.	Min.	Max.	
t_{pd+}	Propagation Delay Input to Output HIGH	$T_A^{(min)} \leq T_A \leq 25^\circ\text{C}$ $T_A = T_A^{(max)}$ (Note 5)		12 15		12 15	ns ns
t_{pd-}	Propagation Delay Input to Output LOW	$T_A^{(min)} \leq T_A \leq 25^\circ\text{C}$ $T_A = T_A^{(max)}$ (Note 5)		12 15		12 15	ns ns
Δt_{pd}	Difference in Propagation Delay between Outputs	$T_A = 25^\circ\text{C}$ (Note 4)		2.0		2.0	ns

Notes:

- 1) For the metal can package, derate at $6.8\text{ mW}/^\circ\text{C}$ for operation at ambient temperatures above $+95^\circ\text{C}$, for the dual-in-line package, derate at $9\text{ mW}/^\circ\text{C}$ for operation at ambient temperatures above 115°C .
- 2) Unless otherwise specified, $V_+ = +5.0\text{ V}$, $V_- = -6.0\text{ V}$ and the Latch Enable input is at V_{OL} . The switching characteristics are for a 100 mV input step with 5.0 mV overdrive.
- 3) The outputs of the Am686 are unstable when biased into their linear range. In order to prevent oscillation, the rate-of-change of the input signal as it passes through the threshold of the comparator must be at least $1\text{ V}/\mu\text{s}$. For slower input signals, a small amount of external positive feedback may be applied around the comparator to give a few millivolts of hysteresis.
- 4) Guaranteed by characterization, not tested.
- 5) Not 100% tested, Group A sample only.

PHYSICAL DIMENSIONS
CD 016

T-90-20

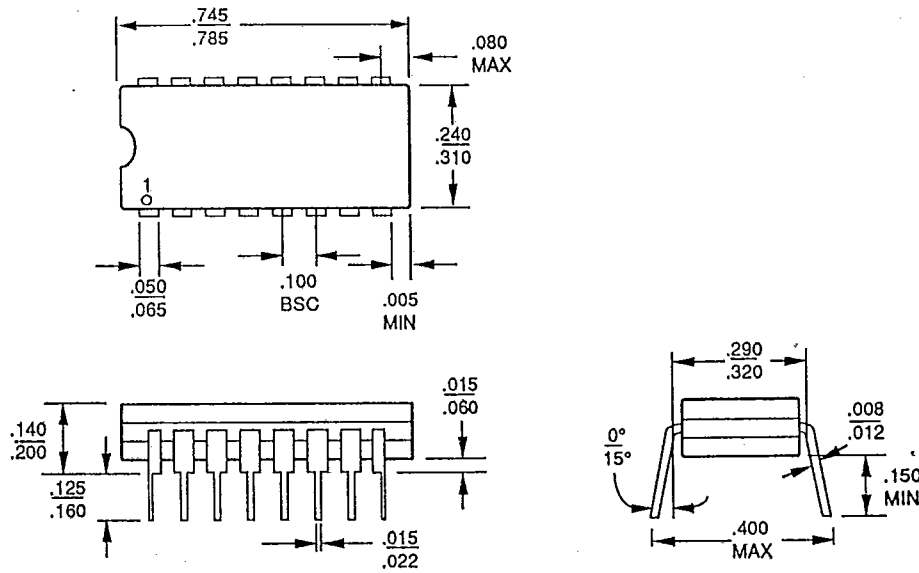

07319B

CD 020

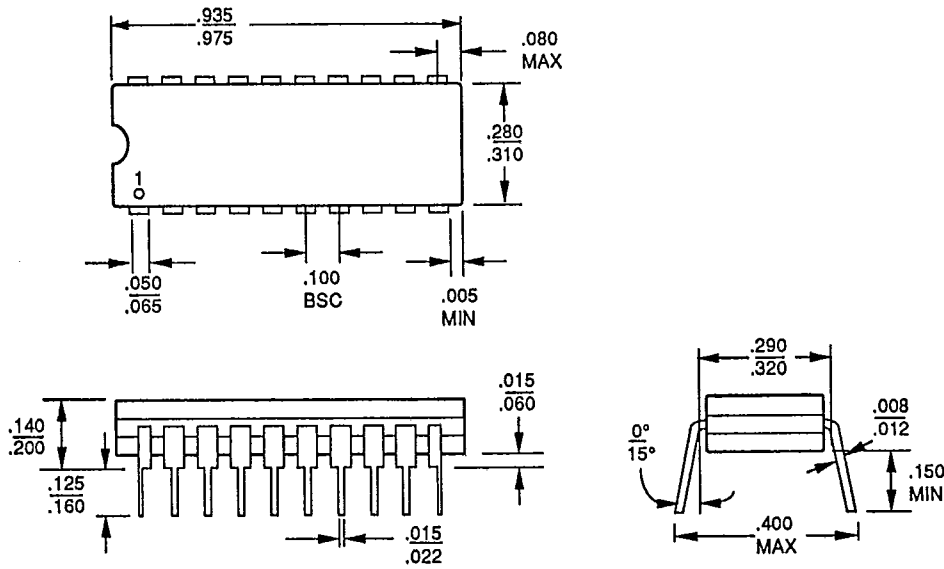

03941-004C

PHYSICAL DIMENSIONS (continued)
CD 024

T-90-20

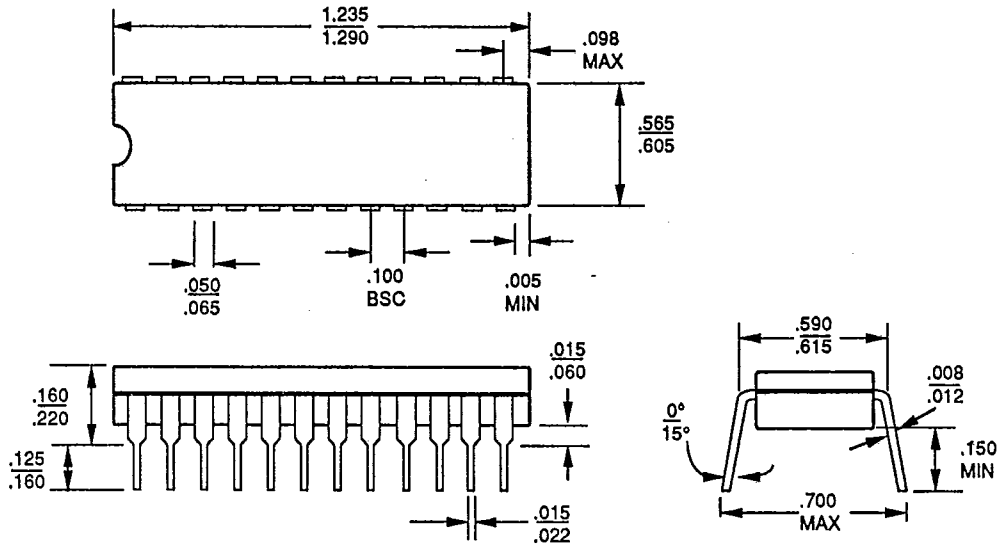

03067-008A

CL 020

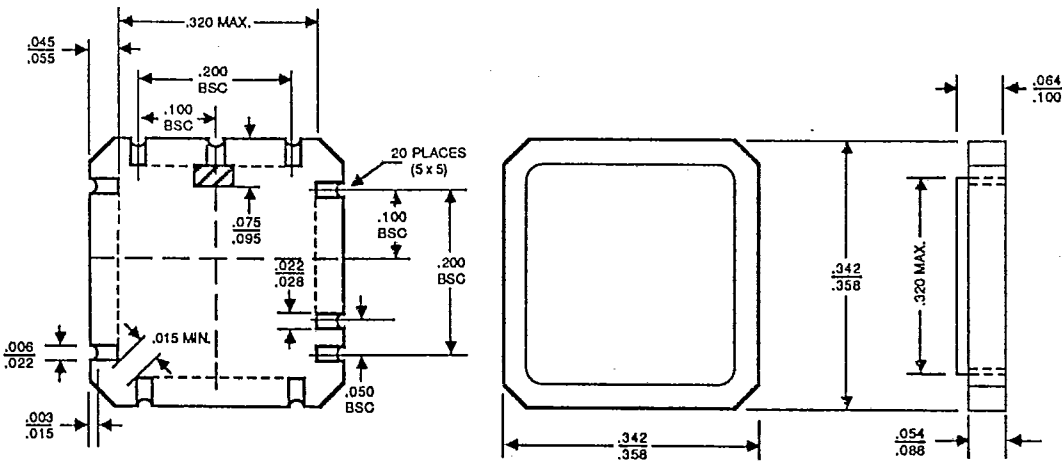

PD #07318C

T-90-20

PHYSICAL DIMENSIONS (continued)
MC 010

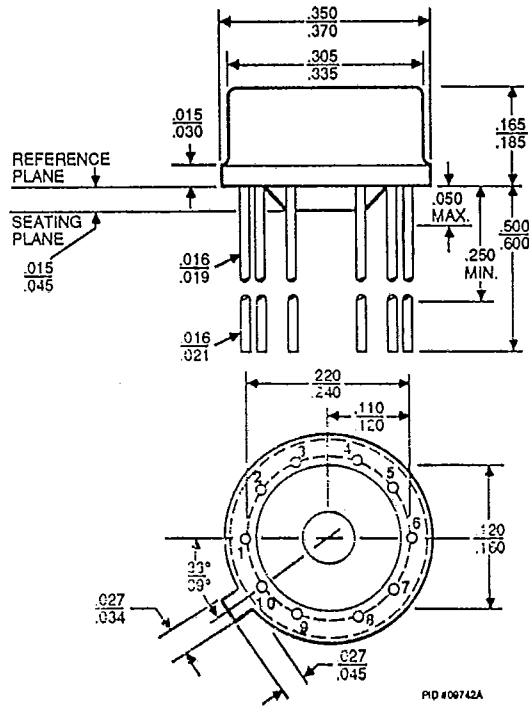

PD 020

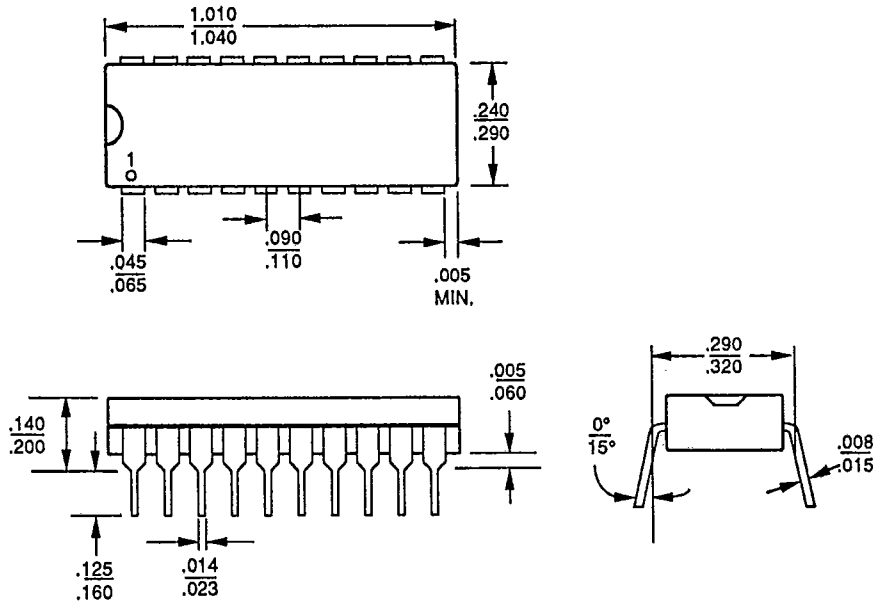

03941-005C