

1.4MHz, 1A Synchronous Buck Converter

Description

The LX7188 is 1.4MHz fixed frequency, current-mode, synchronous PWM buck (step-down) DC-DC converter, capable of driving a 1A load with high efficiency, excellent line and load regulation. The device integrates synchronous P-channel and N-channel power MOSFET switches with low on-resistance. They accept an input voltage range from 2.5V to 5.5V and will enter 100% duty cycle at dropout making them ideal for powering portable equipment that runs from a single Li-ion battery.

A standard series of inductors are available from several different manufacturers optimized for use with the LX7188. This feature greatly simplifies the design of switch-mode power supplies.

The converter includes standard safety features such as over-current, short-circuit and thermal shutdown protection. This device is available in a UDFN 2x2 6L package.

Features

- Input Supply Range: 2.5V to 5.5V
- Output Adjustable from 0.6V to $V_{IN} - 0.5V$
- 100% Duty Cycle in Dropout
- Integrated NMOS & PMOS Switches
- Current Mode Control
- 1A Maximum Output Current
- Fixed 1.4MHz Frequency
- High Efficiency: Up To 96%
- Built-in Soft-start
- Built-in UV & OT Protection
- Built-in Short Circuit Protection
- RoHS Compliant & Halogen Free
- UDFN 2x2 6L Package

Applications

- Datacom
- Portable Devices
- Smart Phone

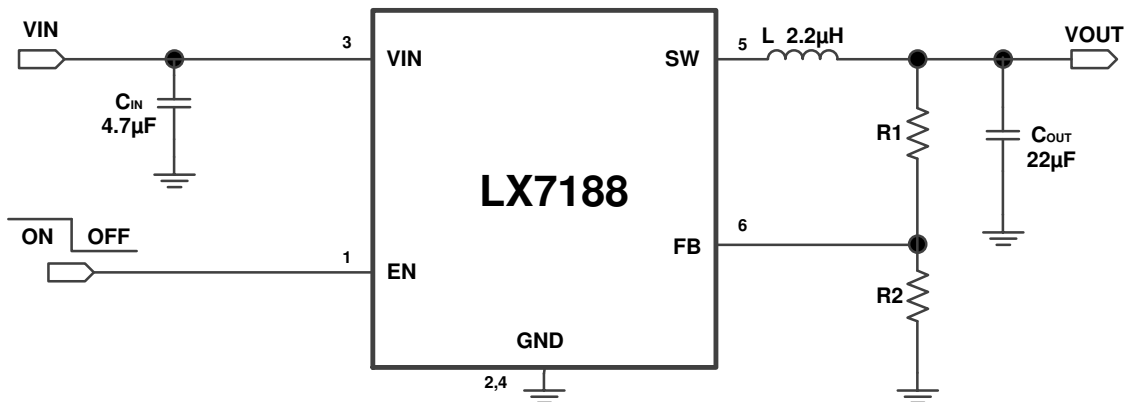

Figure 1 · Typical Application of LX7188

Pin Configuration and Pinout

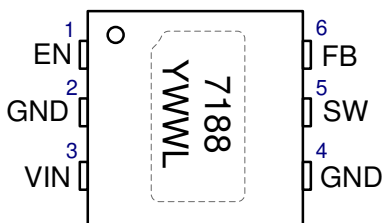

Figure 2 · Pinout UDFN 2x2 6L Top View

Marking: Line1 7188
Line2 YWWL
Year/Work Week/Lot Code

Ordering Information

Ambient Temperature	Type	Package	Part Number	Packaging Type
-40°C to 85°C	RoHS Compliant, Pb-free	UDFN 2x2 6L	LX7188ILU	Bulk / Tube
			LX7188ILU-TR	Tape and Reel

Pin Description

Pin Number	Pin Designator	Description
1	EN	Enable Input. Setting this pin above 1.5V enables the IC. Setting this pin below 0.4V shuts down the IC. When the IC is in shutdown mode, all functions are disabled to decrease the supply current below 1μA.
2,4	GND	Ground Pin.
3	VIN	Supply Input Pin. A 4.7μF ceramic capacitor should be connected between the VIN pin and GND pin to bypass the supply.
5	SW	Power Switch Output Pin. Inductor connection to drain of the internal PFET and NFET switches.
6	FB	Feedback Pin. This pin is connected to an external resistor divider to program the system output voltage.

Block Diagram

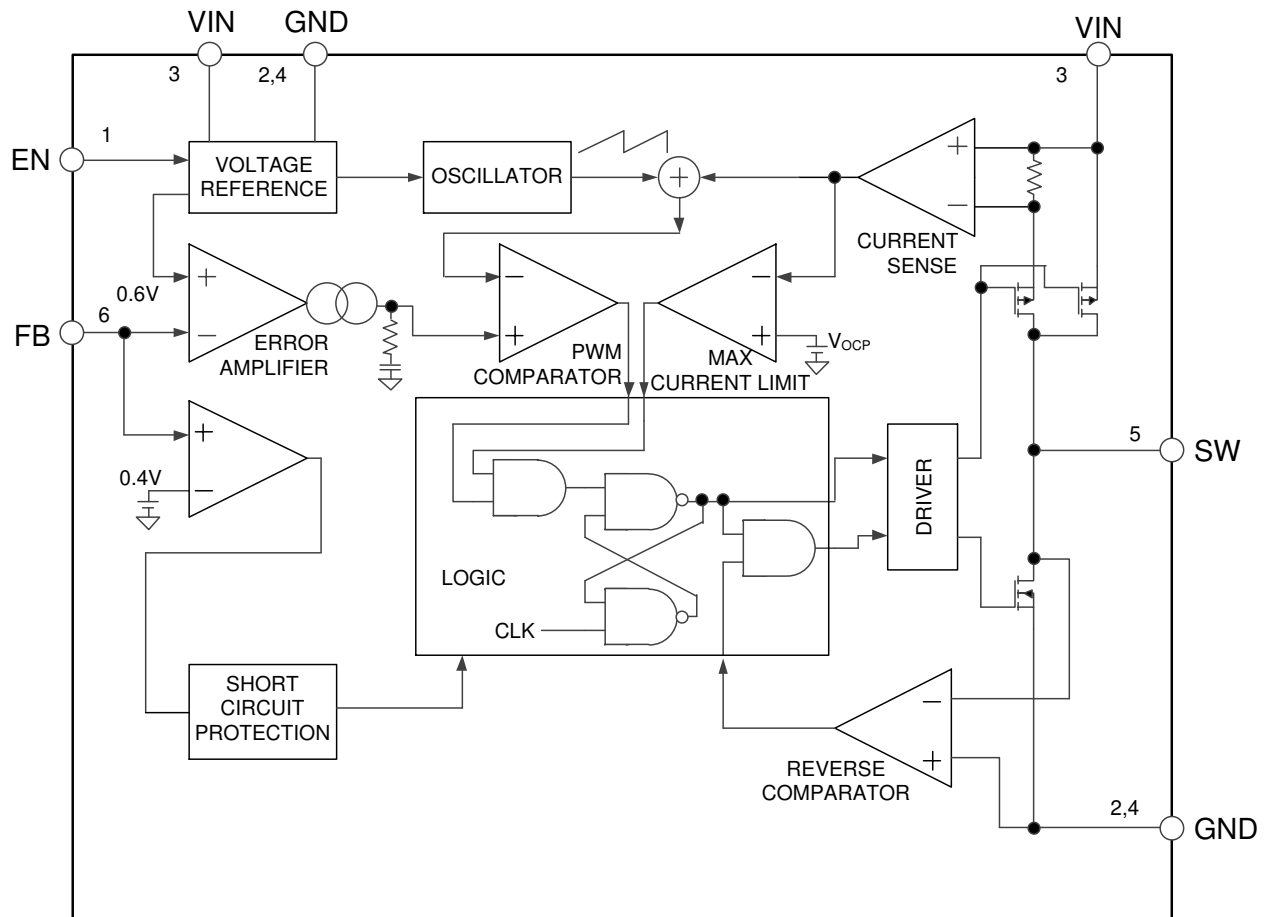

Figure 3 · Simplified Block Diagram of LX7188

Absolute Maximum Ratings

Parameter	Min	Max	Units
VIN to GND	-0.3	6	V
EN, FB to GND	-0.3	VIN + 0.3	V
SW to GND	-0.3	VIN + 0.3	V
Junction Temperature		150	°C
Storage Temperature	-65	150	°C
Peak Package Solder Reflow Temperature (40s, reflow)		260 (+0,-5)	°C
Lead Soldering Temperature (10 seconds)		260	°C

Note: Performance is not necessarily guaranteed over this entire range. These are maximum stress ratings only. Exceeding these ratings, even momentarily, can cause immediate damage, or negatively impact long-term operating reliability

Operating Ratings

	Min	Max	Units
VIN	2.5	5.5	V
VOUT	0.6	VIN – 0.5	V
Ambient Temperature	-40	85	°C
Output Current	0	1	A

Thermal Properties

Thermal Resistance	Typ	Units
θ_{JA}	86	°C/W

Note: The θ_{JA} number assumes no forced airflow. Junction Temperature is calculated using $T_J = T_A + (PD \times \theta_{JA})$. In particular, θ_{JA} is a function of the PCB construction. The stated number above is for a four-layer board in accordance with JESD-51 (JEDEC).

Electrical Characteristics

Note: Unless otherwise specified, the following specifications apply at VIN = VEN = 3.3V. -40°C < TA < 85°C.

Symbol	Parameter	Test Condition	Min	Typ	Max	Units
Operating Current						
IQ	Quiescent Current	VFB = 0.65V		62	100	µA
ISHDN	Shutdown Supply Current	VEN = GND		0.1	1	µA
VIN UVLO						
VUVLO	Under Voltage Lockout	VIN rising		2.3		V
VHYS	UVLO Hysteresis			200		mV

Symbol	Parameter	Test Condition	Min	Typ	Max	Units
FEEDBACK VOLTAGE						
V _{REF}	Feedback Voltage		0.588	0.6	0.612	V
I _{FB}	FB Pin Input Bias Current	V _{FB} = V _{IN}	-100		100	nA
ΔV _{OUT}	Output Voltage Accuracy		-2		2	%
OUTPUT						
R _{DSON_P}	PMOS Switch R _{DSON}	I _{SW} = 200mA		0.28		Ω
R _{DSON_N}	NMOS Switch R _{DSON}	I _{SW} = -200mA		0.25		Ω
I _{LEAK}	NMOS Switch Leakage Current	V _{IN} = 3.3V, V _{SW} = 3.3V		0.1		μA
I _{LIM}	Switch Current Limit	V _{FB} = 0.55V	1.5	2.0		A
T _{OTSD}	Thermal Shutdown			160		°C
T _{HYS}	Thermal Shutdown Hysteresis			20		°C
OSCILLATOR						
f _{OSC}	Oscillator Frequency		1.12	1.40	1.68	MHz
D _{MAX}	Maximum Duty Cycle	V _{FB} = 0V	100			%
D _{MIN}	Minimum Duty Cycle	V _{FB} = 0.65V			0	%
SOFT START						
T _{SS}	Soft Start Time			1		ms
EN INPUT						
V _{EN_H}	EN Pin Threshold		1.5			V
V _{EN_L}					0.4	V

Typical Performance Curves -- (Efficiency in PSM)

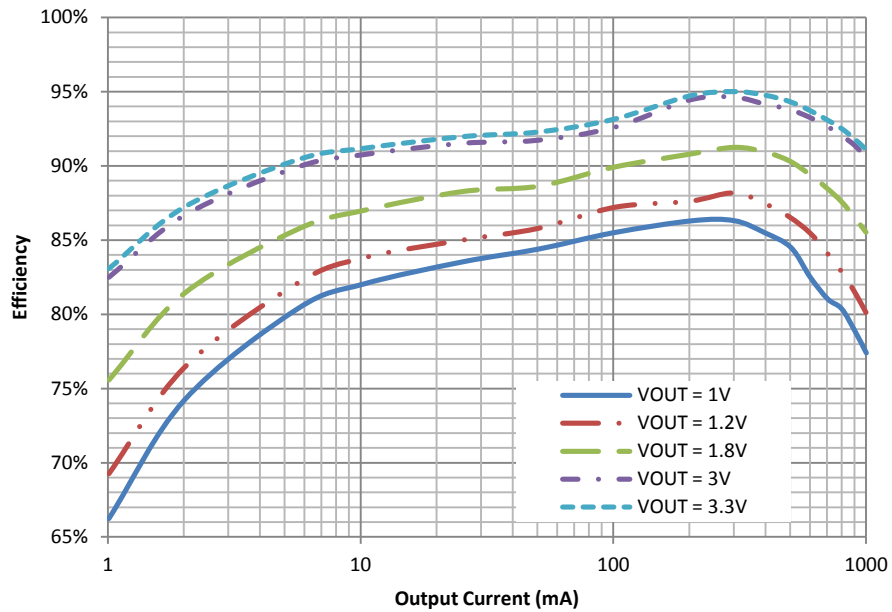

Figure 4 · Efficiency vs. Output Current with 5V Input

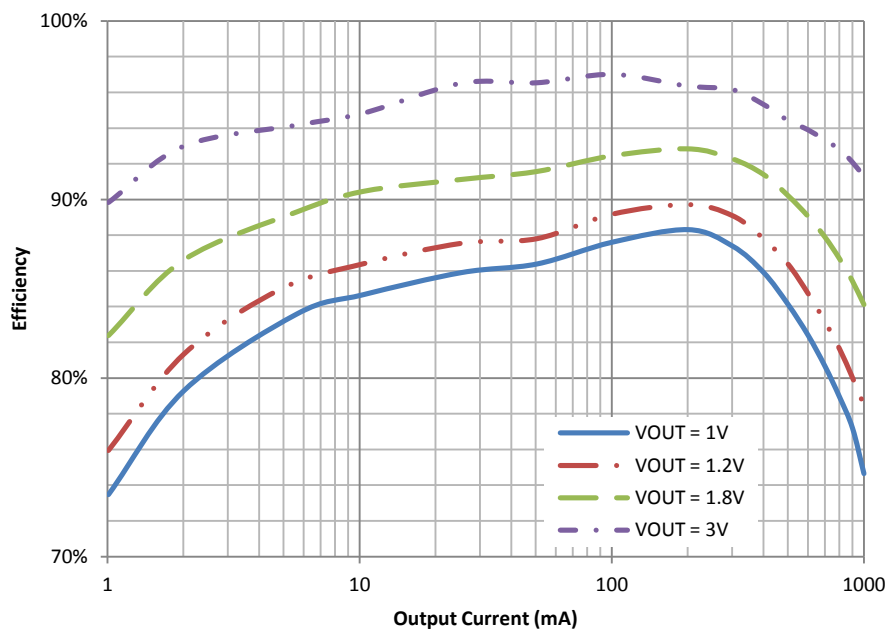

Figure 5 · Output Voltage vs. Output Current with 3.3V Input

Typical Performance Curves -- ($V_{IN} = 3.3V$, $V_{OUT} = 2.5V$)

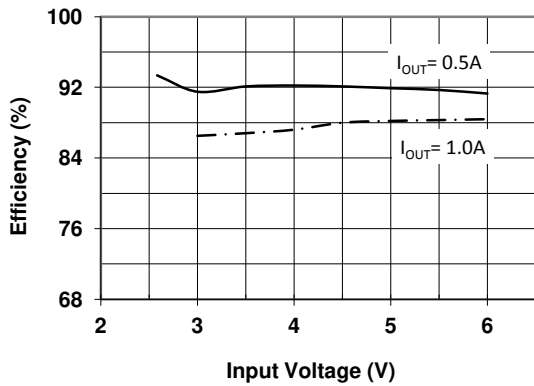

Figure 6 · Efficiency vs. Input Voltage

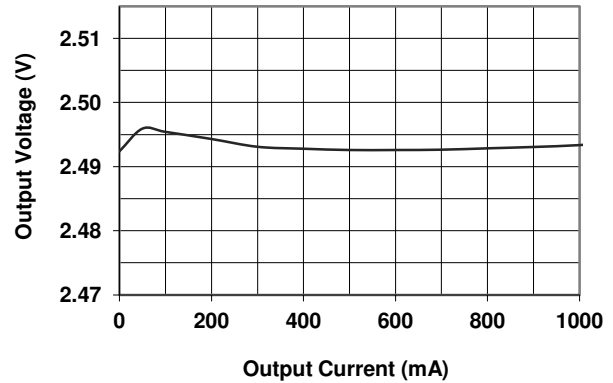

Figure 7 · Output Voltage vs. Output Current

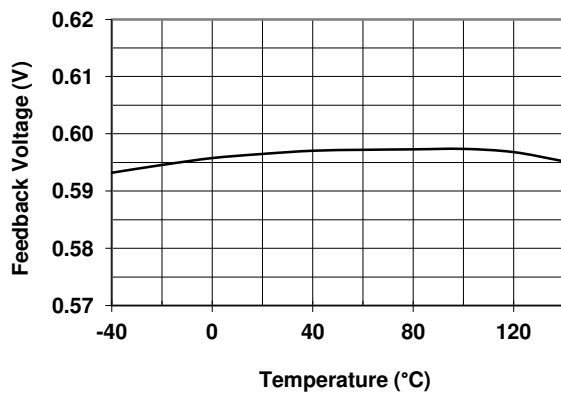

Figure 8 · Feedback Voltage vs. Temperature

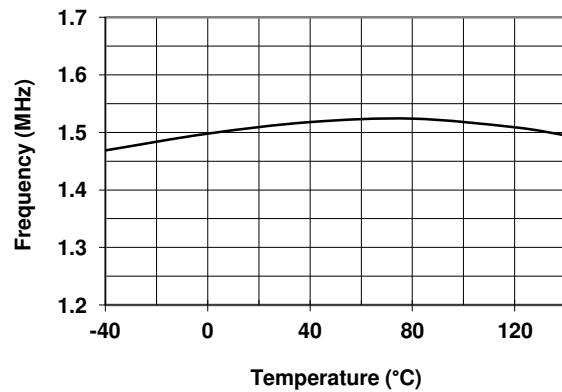

Figure 9 · Frequency vs. Temperature

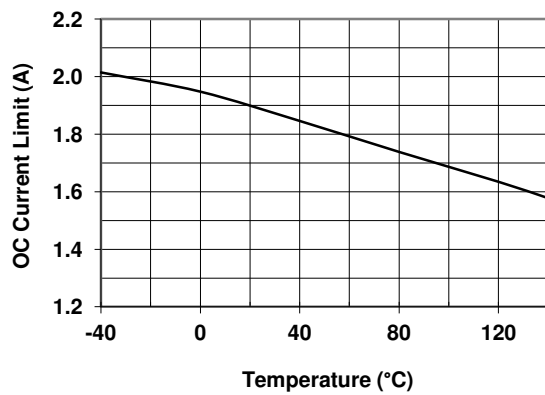

Figure 10 · OCP Current Limit vs. Temperature

Theory of Operation / Application Information

Basic Operation

The LX7188 is a synchronous step-down converter operating with a typically 1.4MHz fixed frequency pulse width modulation (PWM) at moderate to heavy load currents and in power-saving mode (PSM) when operating at light load currents. It is capable of delivering a 1A output current over a wide input voltage range from 2.5 to 5.5V.

At the beginning of each cycle initiated by the clock signal (from the internal oscillator), the P-channel MOSFET switch is turned on, and the inductor current ramps up until the comparator trips and the control logic turns off the switch. The current limit comparator also turns off the switch in case the current limit of the P-channel MOSFET is exceeded. Then the N-channel synchronous switch is turned on and the inductor current ramps down. The next cycle is initiated by the clock signal again, turning off the N-channel synchronous switch and turning on the P-channel switch (See Figure 3).

Two operational modes are available: PSM and PWM. The internal synchronous rectifier with low $R_{DS(on)}$ dramatically reduces conduction loss at PWM mode. No external Schottky diode is required in practical application. The LX7188 enters PSM at extremely light load condition. The equivalent switching frequency is reduced to increase the efficiency in PSM.

As the input supply voltage decreases to a value approaching the output voltage, the duty cycle increases to the maximum. Further reduction of the supply voltage forces the P-channel main switch to remain on for more than one cycle until it reaches 100% duty cycle. The output voltage will then be determined by the input voltage minus the voltage drop across the P-channel MOSFET and the inductor. This is particularly useful in battery powered applications to achieve longest operation time by taking full advantage of the whole battery voltage range.

Typical Application

A general LX7188 application circuit is shown in Figure 11. External component selection is driven by the load requirement, and begins with the selection of the inductor L. Once L is chosen, C_{IN} and C_{OUT} can be selected.

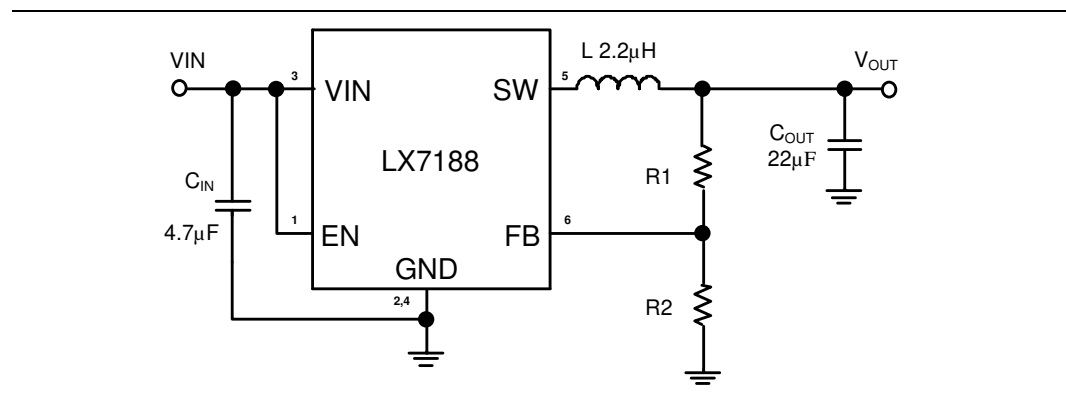

Figure 11 · Typical Application

Component Selection

Inductor Selection

Although the inductor does not influence the operating frequency, the inductor value has a direct effect on ripple current. The inductor ripple current ΔI_L decreases with higher inductance and increases with higher V_{IN} or V_{OUT} .

$$\Delta I_L = \frac{V_{OUT}}{f_{OSC} \times L} \times \left(1 - \frac{V_{OUT}}{V_{IN}}\right)$$

Accepting larger values of ΔI_L allows the use of low inductances, but results in higher output voltage ripple, greater core losses, and lower output current capability. A typical ΔI_L value is 20% to 40% of output current.

Another important parameter for the inductor is the current rating. Exceeding an inductor's maximum current rating may cause the inductor to saturate and overheat. Once the inductor value has been selected, the peak inductor current can be calculated as the following:

$$I_{PEAK} = I_{OUT} + V_{OUT} \times \frac{V_{IN} - V_{OUT}}{2 \times f_{OSC} \times V_{IN} \times L}$$

It should be ensured that the current rating of the selected inductor is 1.5 times of the I_{PEAK} .

Input Capacitor Selection

Because the buck converter has a pulsating input current, a low ESR input capacitor is required. This results in the best input voltage filtering and minimizing the interference with other circuits caused by high input voltage spikes. Also the input capacitor must be sufficiently large to stabilize the input voltage during heavy load transients. Ceramic capacitors show a good performance because of the low ESR value, and they are less sensitive to voltage transients and spikes. Place the input capacitor as close as possible to the input pin of the device for best performance. The typical value is about 4.7 μ F. The X5R or X7R ceramic capacitors have the best temperature and voltage characteristics, which is good for the input capacitor.

Output Capacitor Selection

The output capacitor is the most critical component of a switching regulator, it is used for output filtering and keeping the loop stable. The selection of C_{OUT} is driven by the required ESR to minimize voltage ripple and load step transients. Typically, once the ESR requirement is satisfied, the capacitance is adequate for filtering. The output ripple (ΔV_{OUT}) is determined by:

$$\Delta V_{OUT} \approx \Delta I_L \left(ESR + \frac{1}{8 \times f_{OSC} \times C_{OUT}} \right)$$

The output ripple is highest at maximum input voltage since ΔI_L increases with input voltage.

Once the ESR requirements for C_{OUT} have been met, the RMS current rating generally far exceeds the I_{RIPPLE} (P-P) requirement, except for an all ceramic solution. In most applications, a 22 μ F ceramic capacitor is usually enough for these conditions.

At light load currents, the device operates in PSM mode, and the output voltage ripple is independent of the output capacitor value. The output voltage ripple is set by the internal comparator thresholds. The typical output voltage ripple is 1% of the output voltage V_{OUT} .

Feedback Divider Resistors

The LX7188 develops a 0.6V reference voltage between the feedback pin, FB, and the signal ground as shown in Figure 12. The output voltage is set by a resistive divider according to the following formula:

$$V_{OUT} = 0.6 \times \left(1 + \frac{R1}{R2}\right)$$

Keeping the current small (<40μA) in these resistors maximizes efficiency, but making them too small (<20μA) may allow stray capacitance to cause noise problems and reduce the phase margin of the error amp loop.

The Output resistor divider values are recommended below.

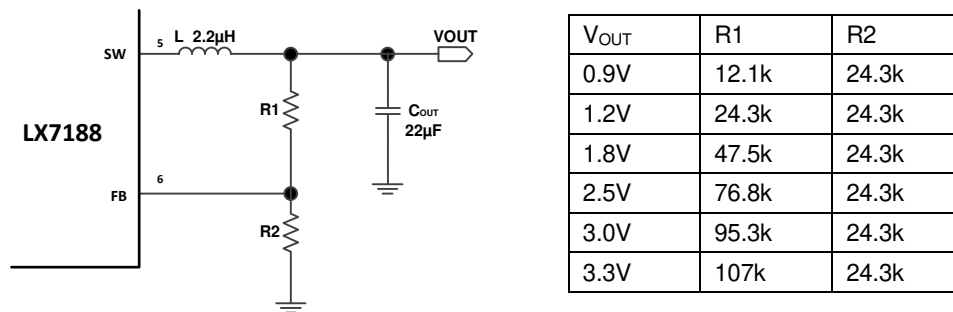

Figure 12 · Output Circuit

Layout Consideration

PCB layout is very important to the performance of the LX7188. The traces where switching current flows should be kept as short as possible. The external components (especially C_{IN}) should be placed as close to the IC as physically possible, therefore use wide and short traces for the main current paths.

Try to route the feedback trace as far from the inductor and noisy power traces as possible. You should also make the feedback trace connection as direct as possible and of reasonable thickness. These two criteria sometimes involve a trade-off, but keeping the trace it away from the inductor and other noise sources is the more critical of the two. Locate the feedback divider resistor network near the feedback pin with short leads.

Flood all unused areas on all layers with copper. Flooding with copper will help to reduce the temperature rise of power components. These copper areas should be connected to one of the input supplies.

PACKAGE OUTLINE DIMENSIONS

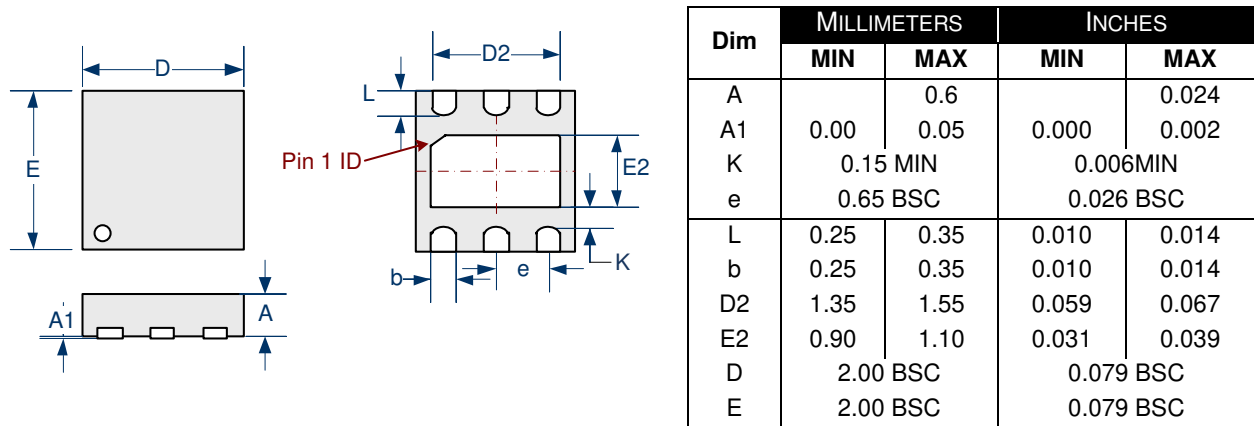

Figure 13 · LU 6-Pin Plastic UDFN 2mm x 2mm x 0.6mm Package Dimensions

- Note:** 1. Dimensions do not include mold flash or protrusions; these shall not exceed 0.155mm(.006”) on any side. Lead dimension shall not include solder coverage.
- Note:** 2. Dimensions are in mm, inches are for reference only.

LAND PATTERN RECOMMENDATION

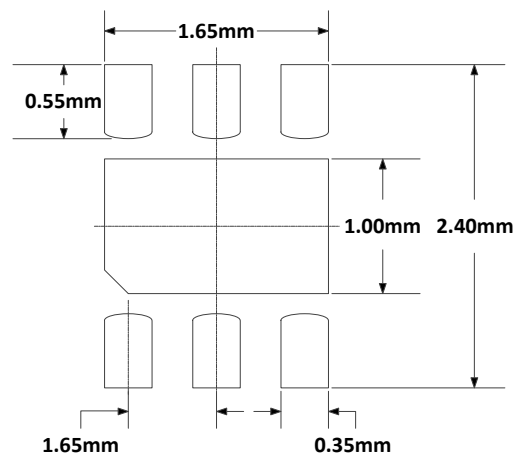

Figure 14 · LU 6-Pin UDFN Package Footprint

Disclaimer: This PCB land pattern recommendation is based on information available to Microsemi by its suppliers. The actual land pattern to be used could be different depending on the materials and processes used in the PCB assembly, end user must account for this in their final layout. Microsemi makes no warranty or representation of performance based on this recommended land pattern.

PRODUCTION DATA – Information contained in this document is proprietary to Microsemi and is current as of publication date. This document may not be modified in any way without the express written consent of Microsemi. Product processing does not necessarily include testing of all parameters. Microsemi reserves the right to change the configuration and performance of the product and to discontinue product at any time.



Microsemi Corporate Headquarters
One Enterprise, Aliso Viejo CA 92656 USA
Within the USA: +1 (949) 380-6100
Sales: +1 (949) 380-6136
Fax: +1 (949) 215-4996

Microsemi Corporation (NASDAQ: MSCC) offers a comprehensive portfolio of semiconductor solutions for: aerospace, defense and security; enterprise and communications; and industrial and alternative energy markets. Products include high-performance, high-reliability analog and RF devices, mixed signal and RF integrated circuits, customizable SoCs, FPGAs, and complete subsystems. Microsemi is headquartered in Aliso Viejo, Calif. Learn more at www.microsemi.com.

© 2013 Microsemi Corporation. All rights reserved. Microsemi and the Microsemi logo are trademarks of Microsemi Corporation. All other trademarks and service marks are the property of their respective owners.