

SHELL SIZE	A ±0.25	B ±0.25	C Maxi	D ±0.15	ØE ±0.15	F Maxi	G ±0.25	H ±0.10	Thread
8	21.00	15.10	21.50	2.30	11.90	11.70	15.10	12.50	7/16 28 UNEF Class 2A
10	23.80	18.30	21.50	2.30	14.90	11.70	18.30	15.10	9/16 24 UNEF Class 2A
12	26.20	20.60	21.50	2.30	18.95	11.70	20.60	18.20	11/16 24 UNEF Class 2A
14	28.60	23.00	21.50	2.30	22.15	11.70	23.00	21.40	13/16 20 UNEF Class 2A

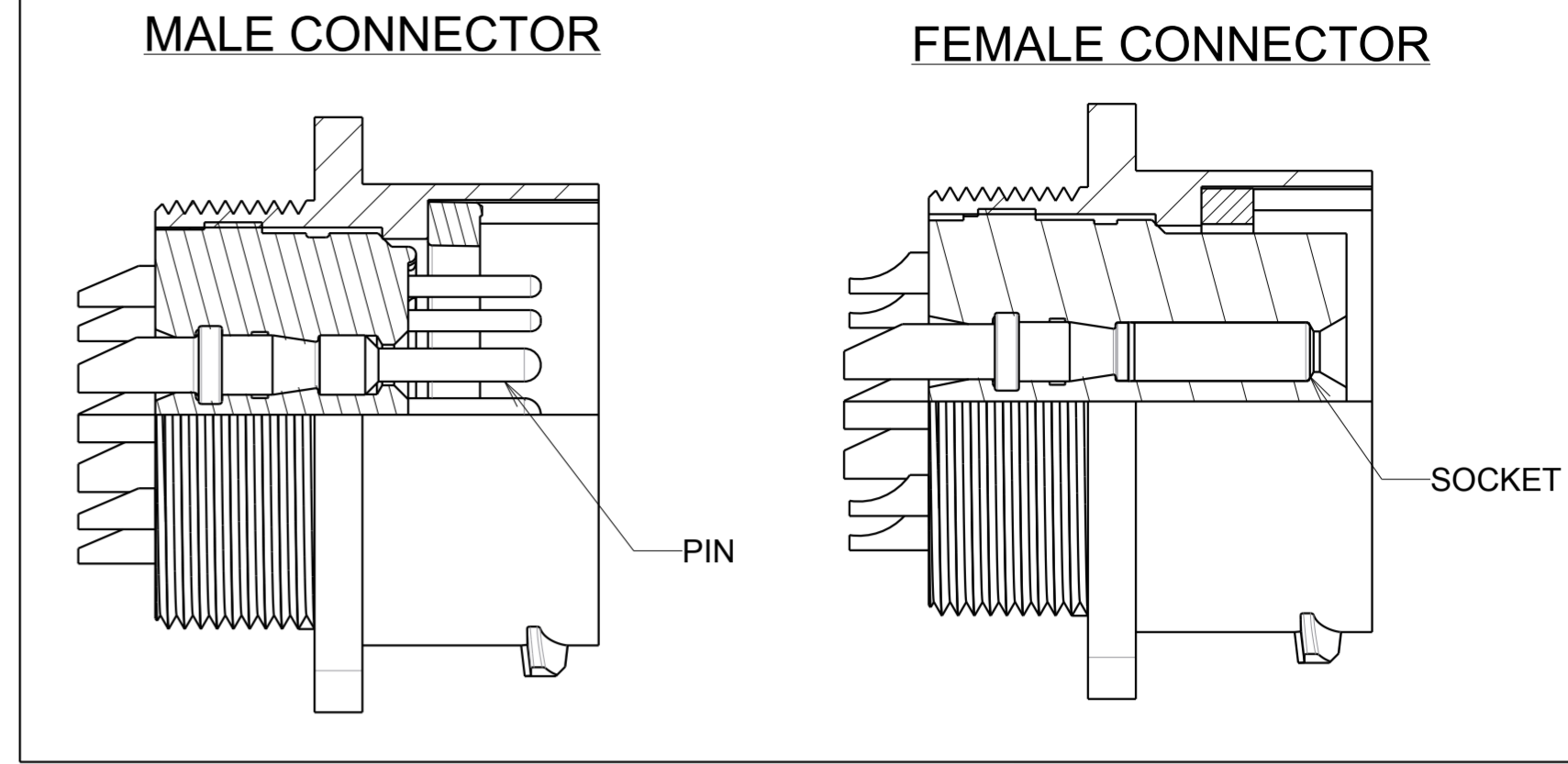

UTS0 14 E 12 P . XX

Square flange receptacle UTS

Shell size

E = Handsolder contacts

Insert arrangement (See table)

P = Male contact

S = Female contact

Orientations

Normal (no digit), W, X, Y, Z = different orientations

Specification

**MATERIAL :**

Shell:PBT UL94 V-0 Black color  
 Insert:Polychloroprene  
 Seal gasket :Sealing IP68/69K : Silicone  
 O'seal : Nitril  
 Contact: brass + gold plated

**PERFORMANCE CHARACTERISTICS :**

Operating temperature:-40° C up to 105° C  
 Insulation resistance:5000 MΩ min  
 Test potential:1500Vrms for #20 layout  
 Corrosion salt spray:500 hours  
 Durability:250 matings and unmatings  
 Sealing in mated and unmated conditions:  
 -IP68 1 bar during 1 week : immersion under 10 m of water.  
 (IEC 60529)  
 -IP69K : exposure to high pressure water of cleaning equipment(DIN 40050)

**NOTE:**

Insert arrangements : refer to C144-UTS1-A

**PANEL CUT OUT**

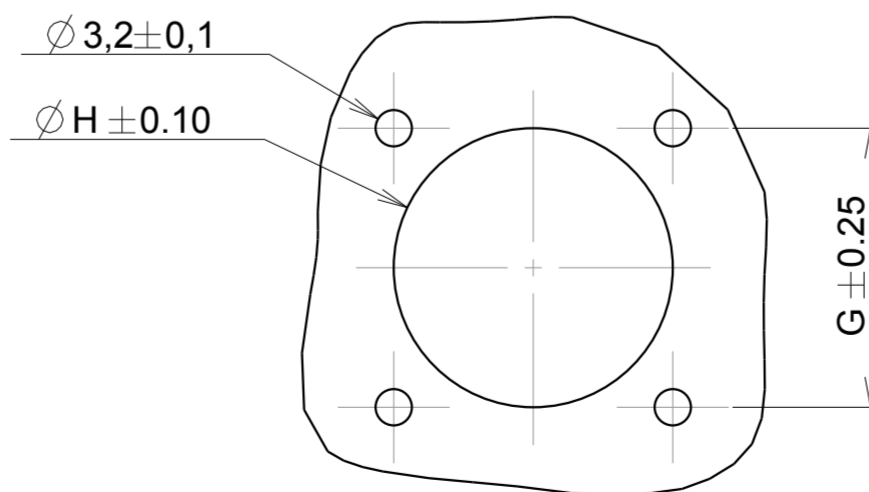

Country	Jurisdiction & Control List
FR	NOT LISTED

P/N : SEE TABLE

E	02/11/2017	Updating shell material	21774A
ISS	DATE	Latest modification - by:	COURTOIS L. MOD N°
Designed by: SORIN V.		Date: 26/10/07	CUSTOMER DRAWING
TITLE		SQUARE FLANGE RECEPTACLE UTS HI SEAL	
Scale	3/1	General linear Tolerances: ± 0.1	NPRDS / PROJECT UTS
SOURIAU		WWW.SOURIAU.COM	
This document is the property of SOURIAU It must not be reproduced or communicated without permission			
FORMAT	SOURIAU DRG N° C044-UTS1-A		SHEET 1 / 1

SOURIAU shall not be liable for any non-conformity or damage due to a use of the Products which does not comply with the Specifications issued by either of the Parties or by a third party (professional recommendation, technical notice.)