

EXTRUSION

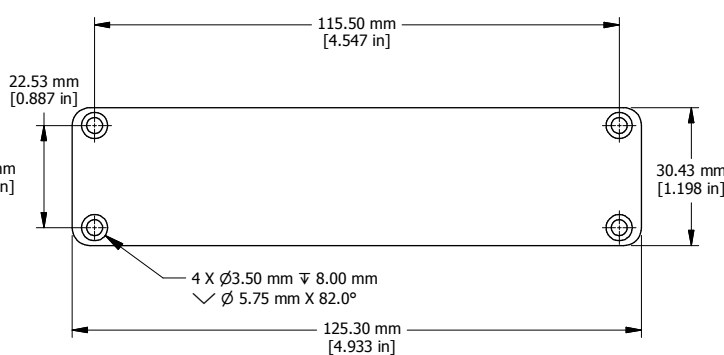

END PLATE

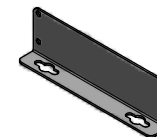

OPTIONAL FLANGE END PANELS  
1455PF

B

B

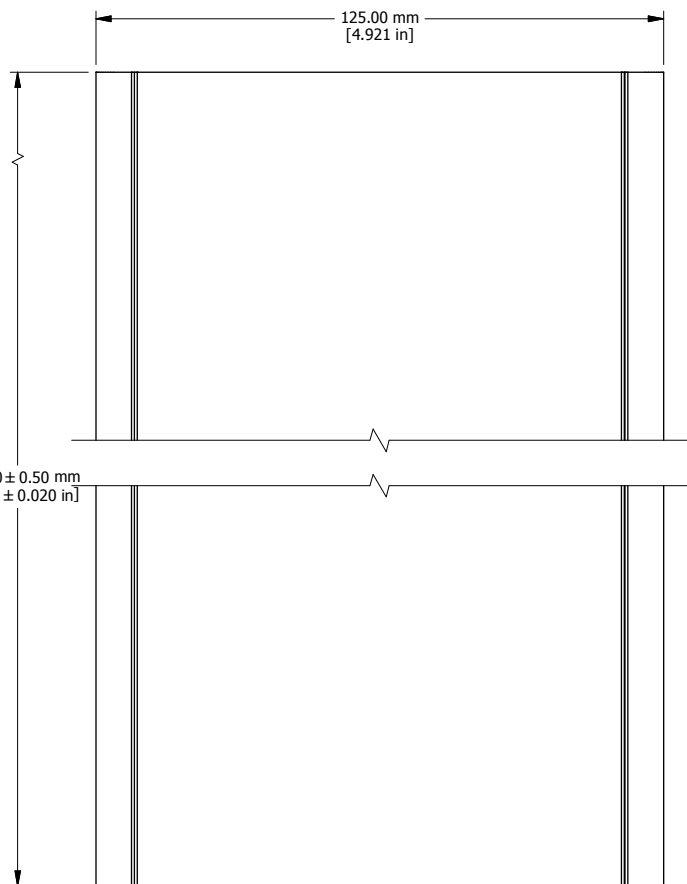

EXTRUSION DESIGNED FOR 120MM WIDE PC BOARD

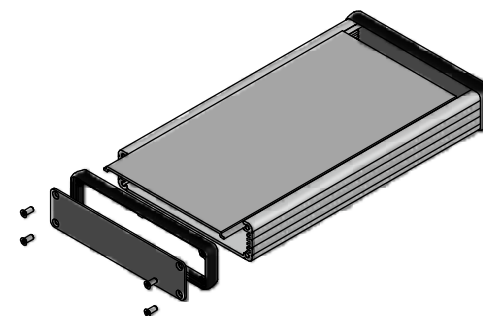

EXPLODED ASSEMBLY VIEW

A

A

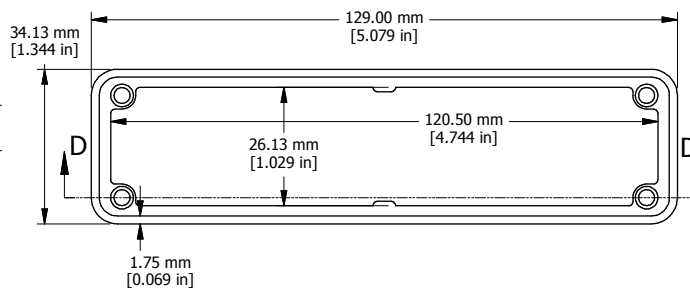

OPEN BEZEL

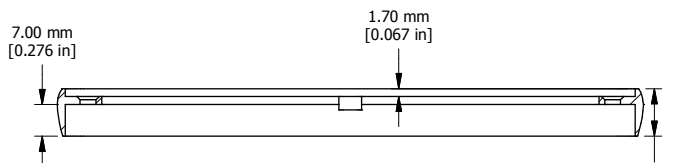

Enclosures can be Factory Modified ( Milling, Drilling, Printing etc. )  
 Solid models of this enclosure available in STEP or IGES.  
 Contact Factory [mjm@hammondmfg.com](mailto:mjm@hammondmfg.com)

**NOTE**  
 Purchased assembly includes box, plastic bezels, end panels, #6  
 Taptight screws and self adhesive rubber feet.  
 Box made from Extruded Aluminum 6063.  
 Bezels made with polycarbonate.

1455P2201	
PART NUMBERS	
Clear Anodized	1455P2201
Black Anodized	1455P2201BK
Blue Anodized	1455P2201BU
Red Anodized	1455P2201RD
ACCESSORIES	
See website for accessories.	

**HAMMOND  
MANUFACTURING™**  
**1455P2201**  
[www.hammondmfg.com](http://www.hammondmfg.com)