

THIS DRAWING IS UNPUBLISHED. RELEASED FOR PUBLICATION
 © COPYRIGHT - TE Connectivity Ltd. ALL RIGHTS RESERVED.

REVISIONS					
P	LTR	DESCRIPTION	DATE	DWN	APVD
E		REVISED PER OL20-0141-97	30JUN97	DKS	MJS
E1		REVISED PER ECO-17-008808	07MAR2018	RS	DR

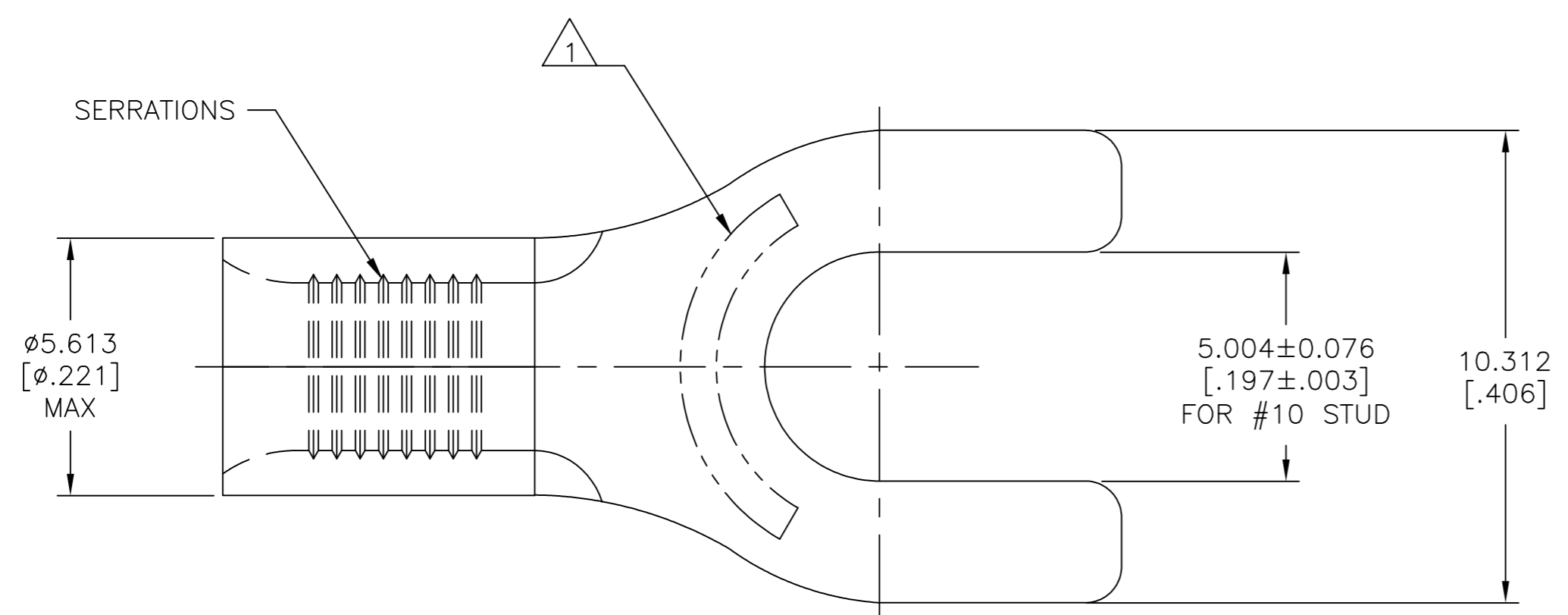

AMP WIRE RANGE	E13288 Listed
12-10 AWG STRANDED	12-10 AWG STRANDED
LR7189 Certified	MILITARY P/N AND CLASS
NOT CERTIFIED	NOT APPLICABLE

STAMP AMP 12-10* APPROX AS SHOWN

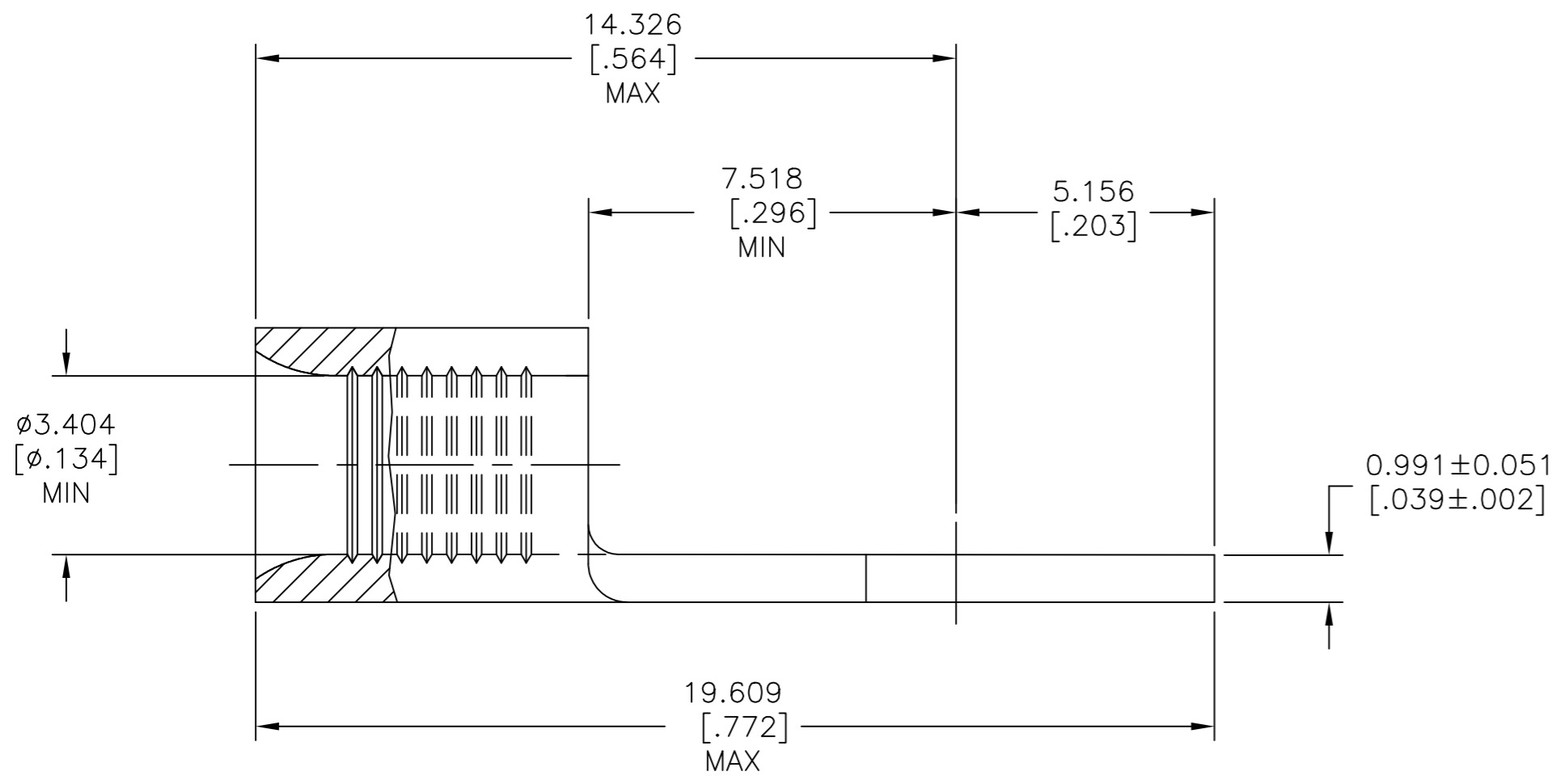

500	LOOSE PIECE	31589
QUANTITY	PACKAGING TYPE	PART NO

AMP INCORPORATED CUSTOMER SERVICE SYSTEMS			THIS DRAWING IS A CONTROLLED DOCUMENT.		DWN TA BRINKMAN 2-18-93	TE Connectivity Ltd.
FOR ADDITIONAL PRODUCT INFORMATION OR COPIES OF DRAWINGS AND TECHNICAL DOCUMENTS	PRODUCT INFORMATION CENTER 1-800-522-6752	MAX RECOMMENDED OPERATING TEMPERATURE: 170°C [338°F] MAX	DIMENSIONS: mm [INCHES]	TOLERANCES UNLESS OTHERWISE SPECIFIED:	CHK DA PATTERSON 2-18-93	
FOR APPLICATION	TOOLING ASSISTANCE CENTER	VOLTAGE RATING: NOT APPLICABLE		0 PLC ± -	APVD DE MILLER 2-18-93	NAME TERMINAL, RING TONGUE, BUDGET, 12-10 AWG
TOOLING INFORMATION	1-800-722-1111	WIRE CROSS SECTIONAL AREA RANGE, 2.62-6.64mm ² [5,180-13,100] CIR MILS STRANDED		1 PLC ± -	2 PLC ± -	
FOR ORDER ENTRY	1-800-526-5142			3 PLC ± 0.127[.005]	APPLICATION SPEC	SIZE A2
				4 PLC ± -	WEIGHT	CAGE CODE 00779
				ANGLES ± -	CUSTOMER DRAWING	DRAWING NO C=31589
				FINISH TIN PLATE 0.00254[.000100] MIN THK PER ASTM B545	SCALE 8:1	SHEET 1 of 1
					REV E1	