

Low Noise, Chopper Stabilized Operational Amplifier

Features

- Low Offset Over Temperature Range: 10 μ V
- Ultra Low Long Term Drift: 150nV/Month
- Low Temperature Drift: 100nV/ $^{\circ}$ C
- Low DC Input Bias Current: 15pA
- High Gain, CMRR and PSRR: 110dB Min
- Low Input Noise Voltage: 0.2 μ V_{p-p} (DC to 1Hz)
- Internally Compensated for Unity Gain Operation
- Clamp Circuit for Fast Overload Recovery

Applications

- Instrumentation
- Medical Instrumentation
- Embedded Control
- Temperature Sensor Amplifier
- Strain Gage Amplifier

Device Selection Table

Part Number	Package	Temperature Range
TC7652CPA	8-Pin Plastic DIP	0 $^{\circ}$ C to +70 $^{\circ}$ C
TC7652CPD	14-Pin Plastic DIP	0 $^{\circ}$ C to +70 $^{\circ}$ C

General Description

The TC7652 is a lower noise version of the TC7650, sacrificing some input specifications (bias current and bandwidth) to achieve a 10x reduction in noise. All the other benefits of the chopper technique are present, (i.e, freedom from offset adjust, drift and reliability problems from external trim components). Like the TC7650, the TC7652 requires only two noncritical external caps for storing the chopped null potentials. There are no significant chopping spikes, internal effects or over-range lockup problems.

Package Type

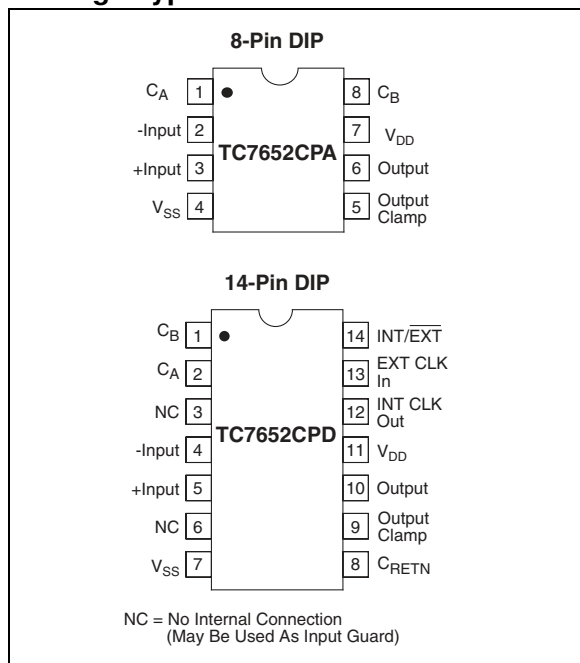

TC7652

Functional Block Diagram

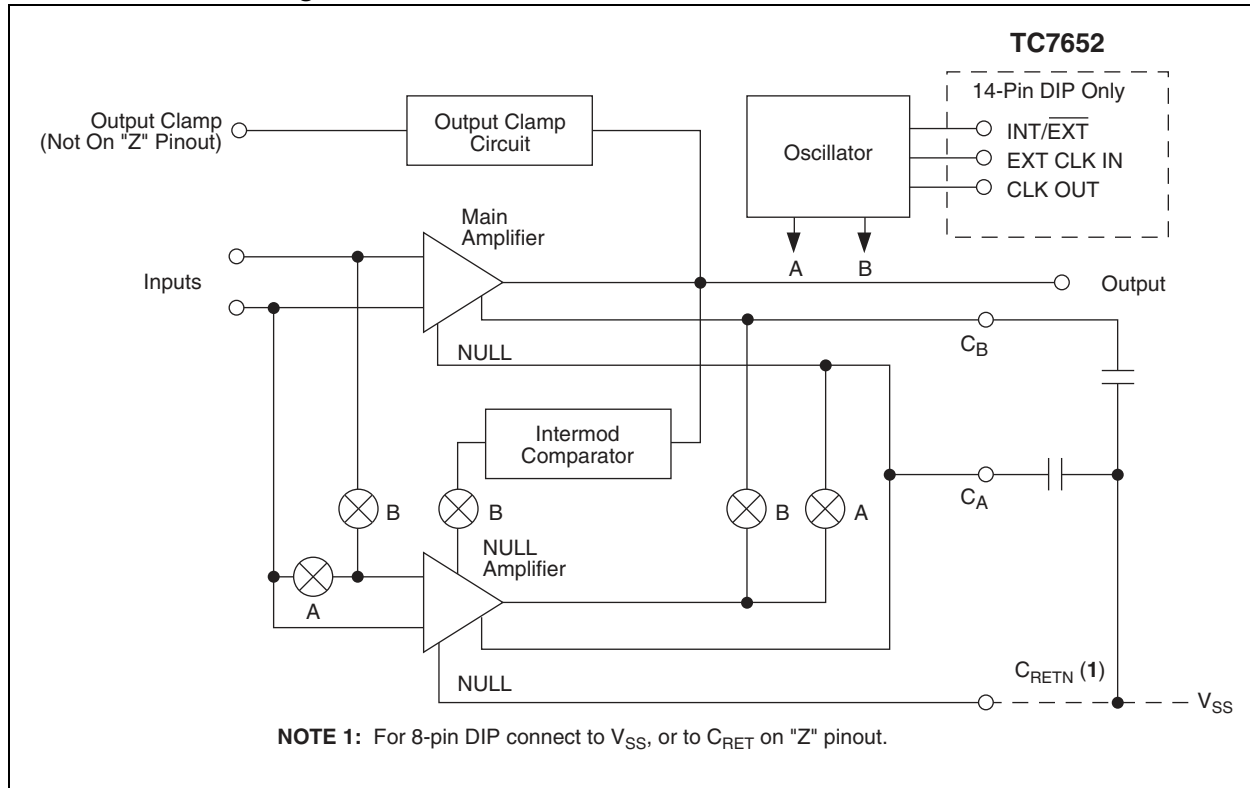

1.0 ELECTRICAL CHARACTERISTICS

ABSOLUTE MAXIMUM RATINGS*

Total Supply Voltage (V_{DD} to V_{SS})	+18V
Input Voltage	($V_{DD} + 0.3V$) to ($V_{SS} - 0.3V$)
Voltage on Oscillator Control Pins	V_{DD} to V_{SS}
Duration of Output Short Circuit	Indefinite
Current Into Any Pin	10mA
While Operating (Note 1)	100 μ A
Package Power Dissipation ($T_A \leq 70^\circ\text{C}$)	
8-Pin Plastic DIP	730mW
14-Pin Plastic DIP	800mW
Storage Temperature Range	-65 $^\circ\text{C}$ to +150 $^\circ\text{C}$
Operating Temperature Range	
C Device	0 $^\circ\text{C}$ to +70 $^\circ\text{C}$
I Device	-25 $^\circ\text{C}$ to +85 $^\circ\text{C}$

*Stresses above those listed under "Absolute Maximum Ratings" may cause permanent damage to the device. These are stress ratings only and functional operation of the device at these or any other conditions above those indicated in the operation sections of the specifications is not implied. Exposure to Absolute Maximum Rating conditions for extended periods may affect device reliability.

TC7652 ELECTRICAL SPECIFICATIONS

Electrical Characteristics: $V_{DD} = +5V$, $V_{SS} = -5V$, $T_A = +25^\circ\text{C}$, unless otherwise indicated.						
Symbol	Parameter	Min	Typ	Max	Units	Test Conditions
V_{OS}	Input Offset Voltage	—	± 2	± 5	μV	$T_A = +25^\circ\text{C}$
TCV_{OS}	Average Temperature Co-efficient of Input Offset Voltage	—	0.01	0.05	$\mu\text{V}/^\circ\text{C}$	$0^\circ\text{C} < T_A < +70^\circ\text{C}$
V_{OS}/DT	Offset Voltage vs Time	—	150	—	nV/mo	
I_{BIAS}	Input Bias Current (CLK On)	—	30 100 250	100 — 1000	pA	$T_A = +25^\circ\text{C}$ $0^\circ\text{C} < T_A < +70^\circ\text{C}$ $-25^\circ\text{C} < T_A < +85^\circ\text{C}$
I_{BIAS}	Input Bias Current (CLK Off)	—	15 35 100	30 — 1000	pA	$T_A = +25^\circ\text{C}$ $0^\circ\text{C} < T_A < +70^\circ\text{C}$ $-25^\circ\text{C} < T_A < +85^\circ\text{C}$
I_{OS}	Input Offset Current	—	25	150	pA	
R_{IN}	Input Resistance	—	10^{12}	—	Ω	
OL	Large Signal Voltage Gain	120	150	—	dB	$R_L = 10\text{k}\Omega$, $V_{OUT} = \pm 4V$
V_{OUT}	Output Voltage Swing (Note 2)	± 4.7 —	± 4.85 ± 4.95	— —	V	$R_L = 10\text{k}\Omega$ $R_L = 100\text{k}\Omega$
CMVR	Common Mode Voltage Range	-4.3	—	+3.5	V	
MRR	Common Mode Rejection Ratio	120	140	—	dB	CMVR = -4.3V to +3.5V
PSRR	Power Supply	120	140	—	dB	$\pm 3V$ to $\pm 8V$
e_N	Input Noise Voltage	—	0.2 0.7	1.5 5	μV_{P-P} μV_{P-P}	$R_S = 100\Omega$, DC to 1Hz DC to 10Hz
I_N	Input Noise Current	—	0.01	—	$\text{pA}/\sqrt{\text{Hz}}$	$f = 10\text{Hz}$
GBW	Unity Gain Bandwidth	—	0.4	—	MHz	
SR	Slew Rate	—	1	—	V/ μsec	$C_L = 50\text{pF}$, $R_L = 10\text{k}\Omega$
	Overshoot	—	15	—	%	
V_{DD} , V_{SS}	Operating Supply Range	5	—	16	V	

- Note 1:** Limiting input current to 100 μA is recommended to avoid latch-up problems. Typically 1mA is safe however, this is not guaranteed.
- Note 2:** Output clamp not connected. See typical characteristics curves for output swing versus clamp current characteristics.
- Note 3:** See "Output Clamp" under detailed description.

TC7652

TC7652 ELECTRICAL SPECIFICATIONS (CONTINUED)

Electrical Characteristics: $V_{DD} = +5V$, $V_{SS} = -5V$, $T_A = +25^{\circ}C$, unless otherwise indicated.						
Symbol	Parameter	Min	Typ	Max	Units	Test Conditions
I_S	Supply Current	—	1	3	mA	No Load
f_{CH}	Internal Chopping Frequency	100	275	—	Hz	Pins 12 – 14 Open (DIP)
	Clamp ON Current (Note 3)	25	100	—	μA	$R_L = 100k\Omega$
	Clamp OFF Current (Note 3)	—	1	—	pA	$-4V \leq V_{OUT} < +10V$

Note 1: Limiting input current to $100\mu A$ is recommended to avoid latch-up problems. Typically 1mA is safe however, this is not guaranteed.

Note 2: Output clamp not connected. See typical characteristics curves for output swing versus clamp current characteristics.

Note 3: See "Output Clamp" under detailed description.

2.0 PIN DESCRIPTIONS

The descriptions of the pins are listed in Table 2-1.

TABLE 2-1: PIN FUNCTION TABLE

Pin Number		Symbol	Description
8-pin DIP	14-pin DIP		
1,8	2,1	C_A, C_B	Nulling capacitor pins
2	4	-INPUT	Inverting Input
3	5	+INPUT	Non-inverting Input
4	7	V_{SS}	Negative Power Supply
5	9	OUTPUT CLAMP	Output Voltage Clamp
6	10	OUTPUT	Output
7	11	V_{DD}	Positive Power Supply
—	3,6	NC	No internal connection
—	8	C_{RETN}	Capacitor current return pin
—	12	INT CLK OUT	Internal Clock Output
—	13	EXT CLK IN	External Clock Input
—	14	INT/EXT	Select Internal or External Clock

TC7652

3.0 DETAILED DESCRIPTION

3.1 Capacitor Connection

Connect the null storage capacitors to the C_A and C_B pins with a common connection to the C_{RET} pin (14-pin TC7652) or to V_{SS} (8-pin TC7652). When connecting to V_{SS} , avoid injecting load current IR drops into the capacitive circuitry by making this connection directly via a separate wire or PC trace.

3.2 Output Clamp

In chopper stabilized amplifiers, the output clamp pin reduces overload recovery time. When a connection is made to the inverting input pin (summing junction), a current path is created between that point and the output pin, just before the device output saturates. This prevents uncontrolled differential input voltages and charge build-up on correction storage capacitors. Output swing is reduced.

3.3 Clock

The TC7652 has a 550Hz internal oscillator, which is divided by two before clocking the input chopper switches. The 275Hz chopping frequency is available at INT CLK OUT (Pin 12) on 14-pin devices. In normal operation, INT/EXT (Pin 14), which has an internal pull-up, can be left open.

An external clock can also be used. To disable the internal clock and use an external one, the INT/EXT pin must be tied to V_{SS} . The external clock signal is then applied to the EXT CLK IN input (Pin 13). An internal divide-by-two provides a 50% switching duty cycle. The capacitors are only charged when EXT CLK IN is high, so a 50% to 80% positive duty cycle is recommended for higher clock frequencies. The external clock can swing between V_{DD} and V_{SS} , with the logic threshold about 2.5V below V_{DD} .

The output of the internal oscillator, before the divide-by-two circuit, is available at EXT CLK IN when INT/EXT is high or unconnected. This output can serve as the clock input for a second TC7652 (operating in a master/slave mode), so that both op amps will clock at the same frequency. This prevents clock intermodulation effects when two TC7652's are used in a differential amplifier configuration.

FIGURE 3-1: TEST CIRCUIT

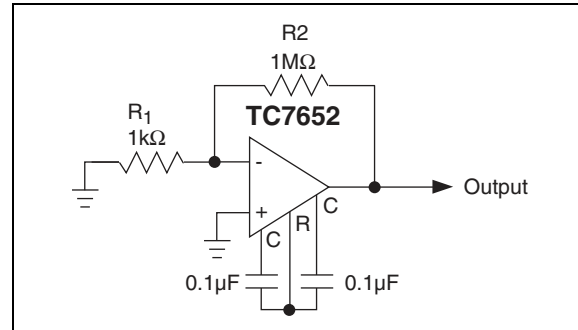

If the TC7652's output saturates, error voltages on the external capacitors will slow overload recovery. This condition can be avoided if a strobe signal is available. The strobe signal is applied to EXT CLK IN and the overload signal is applied to the amplifier while the strobe is LOW. In this case, neither capacitor will be charged. The low leakage of the capacitor pins allow long measurements to be made within eligible errors (typical capacitor drift is 10 μ V/sec).

4.0 TYPICAL APPLICATIONS

4.1 Component Selection

C_A and C_B (external capacitors) should be in the 0.1 μ F to 1 μ F range. For minimum clock ripple noise, use a 1 μ F capacitor in broad bandwidth circuits. For limited bandwidth applications where clock ripple is filtered out, use a 0.1 μ F capacitor for slightly lower offset voltage. High quality, film type capacitors (polyester or polypropylene) are recommended, although a lower grade ceramic may work in some applications. For quickest settling after initial turn-on, use low dielectric absorption capacitors (e.g., polypropylene). With ceramic capacitors, settling to 1 μ V takes several seconds.

4.2 Static Protection

Although input diodes static protect all device pins, avoid strong electrostatic fields and discharges that can cause degraded diode junction characteristics and produce increased input-leakage currents.

4.3 Output Stage/Load Driving

The output circuit is high impedance (about 18k Ω). With lesser loads, the chopper amplifier behaves somewhat like a transconductance amplifier with an open-loop gain proportional to load resistance. (For example, the open-loop gain is 17dB lower with a 1k Ω load than with a 10k Ω load.) If the amp is used only for DC, the DC gain is typically greater than 120dB (even

with a 1k Ω load), and this lower gain is inconsequential. For wide band, the best frequency response occurs with a load resistor of at least 10k Ω . This produces a 6dB/octave response from 0.1Hz to 2MHz, with phase shifts of less than 2 degrees in the transition region, where the main amplifier takes over from the null amplifier.

FIGURE 4-1: CONNECTION OF INPUT GUARDS

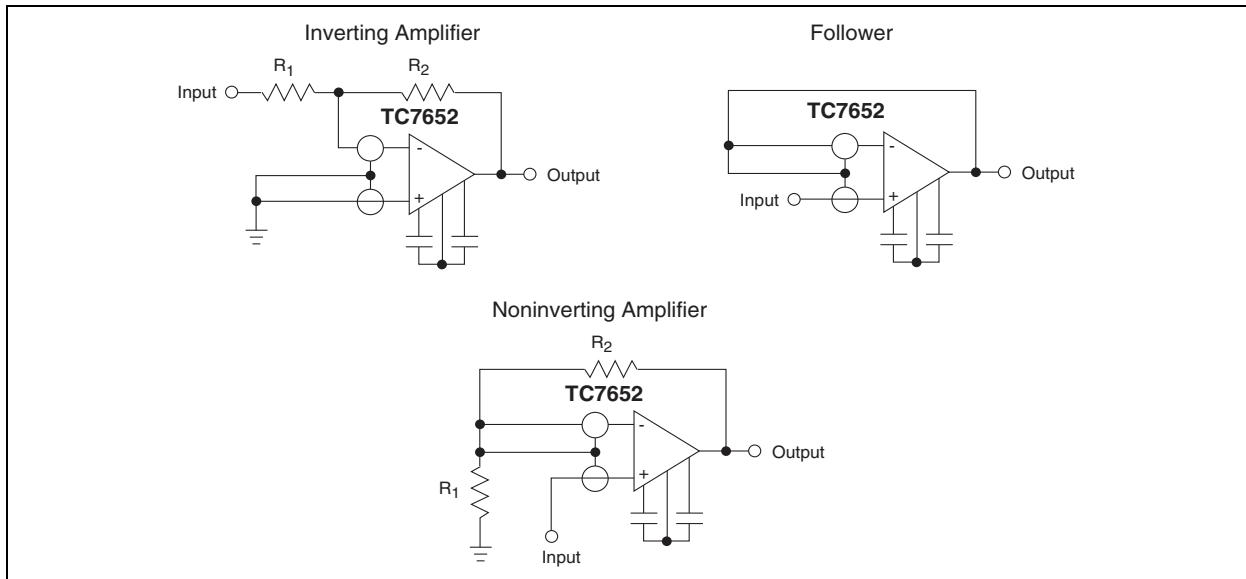

4.4 Thermoelectric Effects

The thermoelectric (Seebeck) effects in thermocouple junctions of dissimilar metals, alloys, silicon, etc. limit ultra high precision DC amplifiers. Unless all junctions are at the same temperature, thermoelectric voltages around 0.1 μ V/ $^{\circ}$ C (up to tens of μ V/ $^{\circ}$ C for some materials) are generated. To realize the low offset voltages of the chopper, avoid temperature gradients. Enclose components to eliminate air movement, especially from power dissipating elements in the system. Where possible, use low thermoelectric co-efficient connections. Keep power supply voltages and power dissipation to a minimum. Use high impedance loads and seek maximum separation from surrounding heat dissipating elements.

4.5 Guarding

To benefit from TC7652 low input currents, take care assembling printed circuit boards. Clean boards with alcohol or TCE and blow dry with compressed air. To prevent contamination, coat boards with epoxy or silicone rubber.

Even if boards are cleaned and coated, leakage currents may occur because input pins are next to pins at supply potentials. To reduce this leakage, use guarding to lower the voltage difference between the inputs and adjacent metal runs. The guard (a conductive ring surrounding inputs) is connected to a low impedance point at about the same voltage as inputs. The guard absorbs leakage currents from high voltage pins.

The 14-pin dual-in-line arrangement simplifies guarding. Like the LM108 pin configuration (but unlike the 101A and 741), pins next to inputs are not used.

4.6 Pin Compatibility

Where possible, the 8-pin device pinout conforms to such industry standards as the LM101 and LM741. Null storing external capacitors connect to Pins 1 and 8, which are usually for offset null or compensation capacitors. Output clamp (Pin 5) is similarly used. For OP05 and OP07 devices, replacement of the offset null potentiometer (connected between Pins 1 and 8 and V_{DD} by two capacitors from those pins to V_{SS}) provides compatibility. Replacing the compensation capacitor between Pins 1 and 8 by two capacitors to V_{SS} is required. The same operation (with the removal of any connection to Pin 5) works for LM101, $\mu A748$ and similar parts.

Because NC pins provide guarding between input and other pins, the 14-pin device pinout conforms closely to the LM108. Because this device does not use any extra pins and does not provide offset nulling (but requires a compensation capacitor), some layout changes are necessary to convert to the TC7652.

4.7 Some Applications

Figures 4-2 and 4-3 show basic inverting and noninverting amplifier circuits using the output clamping circuit to enhance overload recovery performance. The only limitations on replacing other op amps with the TC7652 are supply voltage ($\pm 8V$ maximum) and output drive capability (10k Ω load for full swing). Overcome these limitations with a booster circuit (Figure 4-4) to combine output capabilities of the LM741 (or other standard device) with input capabilities of the TC7652. These two form a composite device, therefore, when adding the feedback network, the monitor loop gains stability.

FIGURE 4-2: NONINVERTING AMPLIFIER WITH OPTIONAL CLAMP

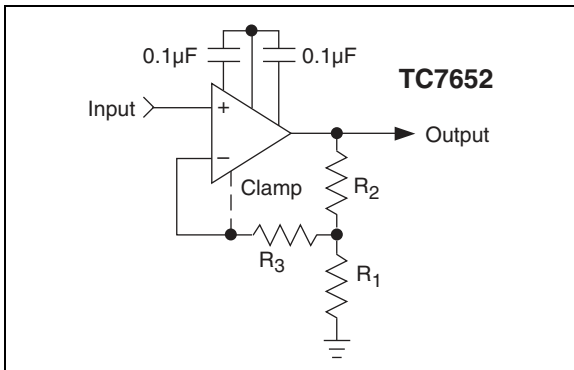

FIGURE 4-3: INVERTING AMPLIFIER WITH OPTIONAL CLAMP

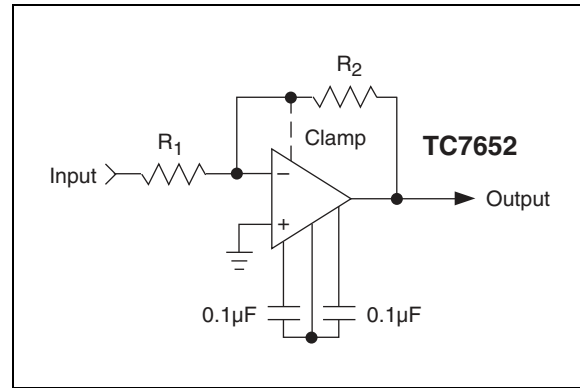

FIGURE 4-4: USING 741 TO BOOST OUTPUT DRIVE CAPABILITY

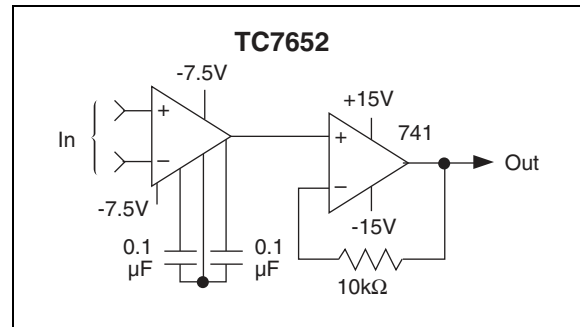

Figure 4-5 shows the clamp circuit of a zero offset comparator. Because the clamp circuit requires the inverting input to follow the input signal, problems with a chopper stabilized op amp are avoided. The threshold input must tolerate the output clamp current $\approx V_{IN}/R$ without disrupting other parts of the system.

Figure 4-6 shows how the TC7652 can offset null high slew rate and wideband amplifiers.

Mixing the TC7652 with circuits operating at $\pm 15V$ requires a lower supply voltage divider with the TC7660 voltage converter circuit operated "backwards." Figure 4-7 shows an approximate connection.

FIGURE 4-5: LOW OFFSET COMPARATOR

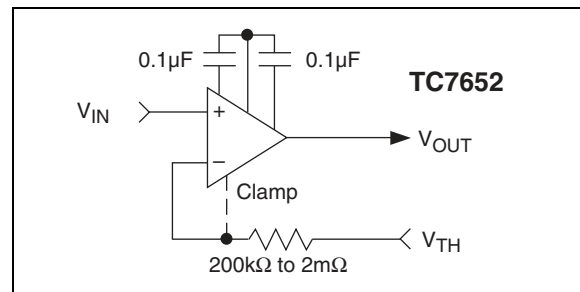

FIGURE 4-6: 1437 OFFSET NULLED BY TC7652

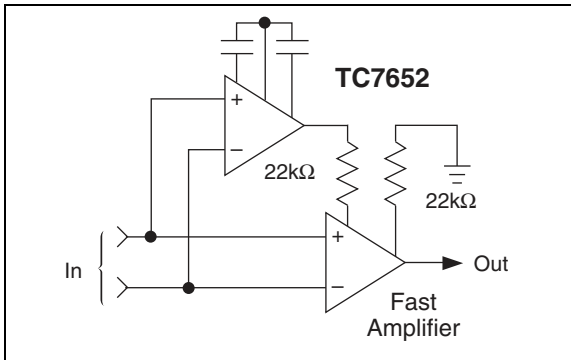
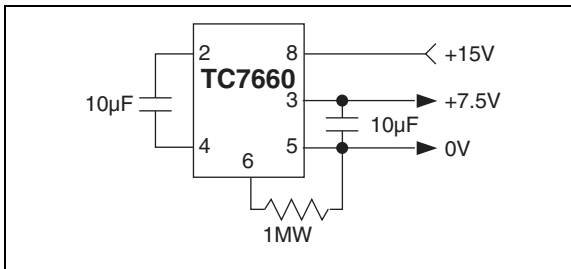

FIGURE 4-7: SPLITTING +15V WITH THE 7660 AT >95% EFFICIENCY



TC7652

5.0 TYPICAL CHARACTERISTICS

Note: The graphs and tables provided following this note are a statistical summary based on a limited number of samples and are provided for informational purposes only. The performance characteristics listed herein are not tested or guaranteed. In some graphs or tables, the data presented may be outside the specified operating range (e.g., outside specified power supply range) and therefore outside the warranted range.

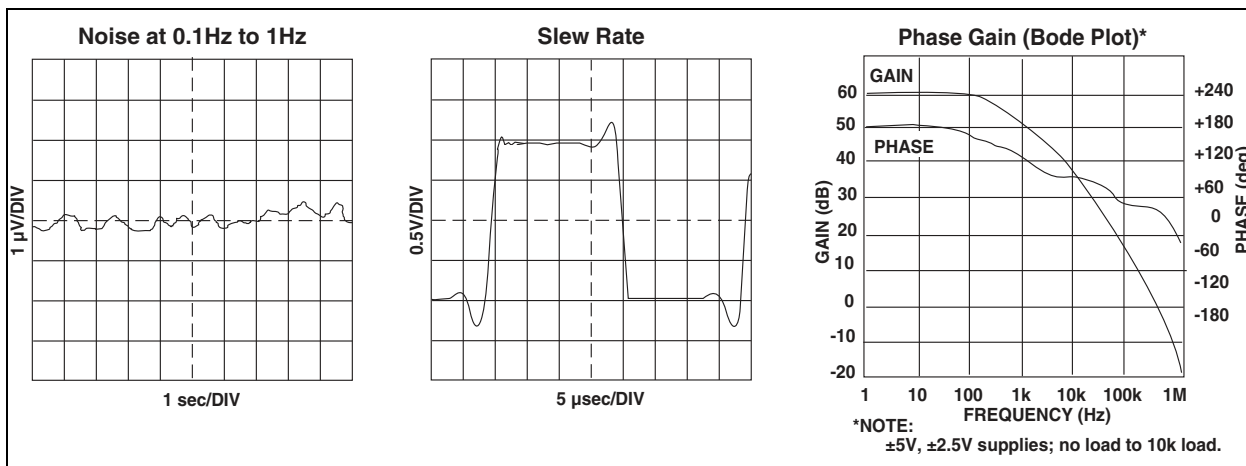
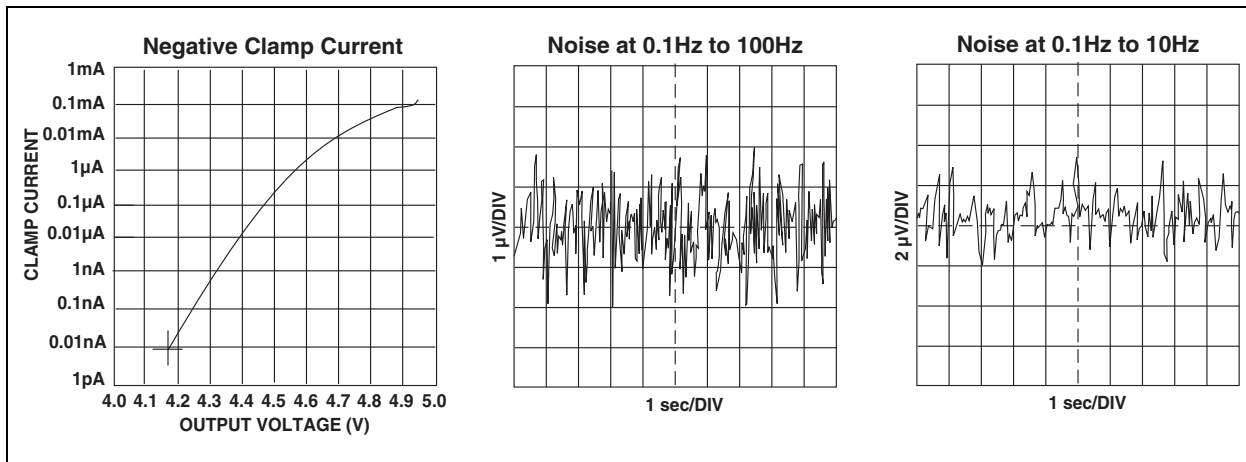
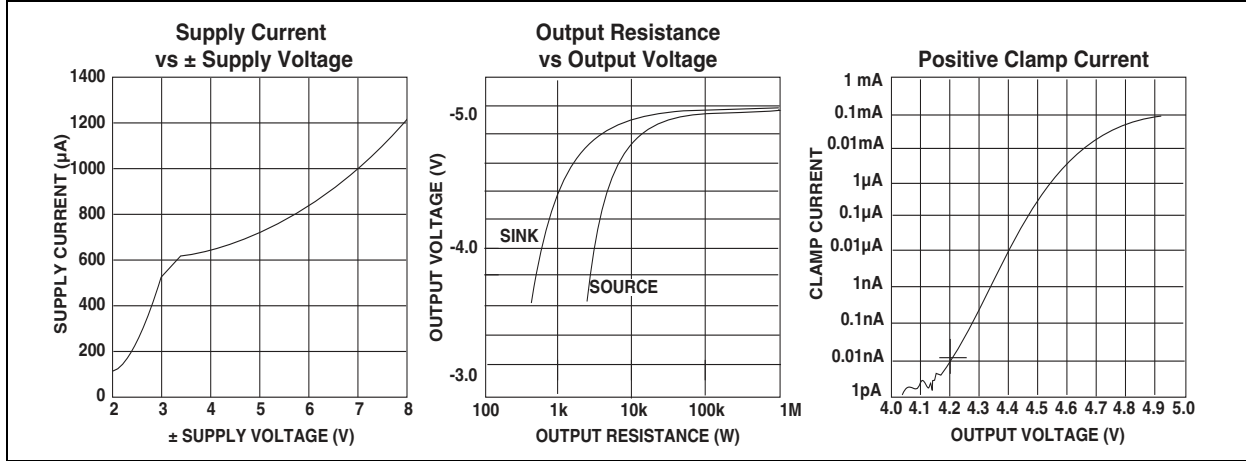

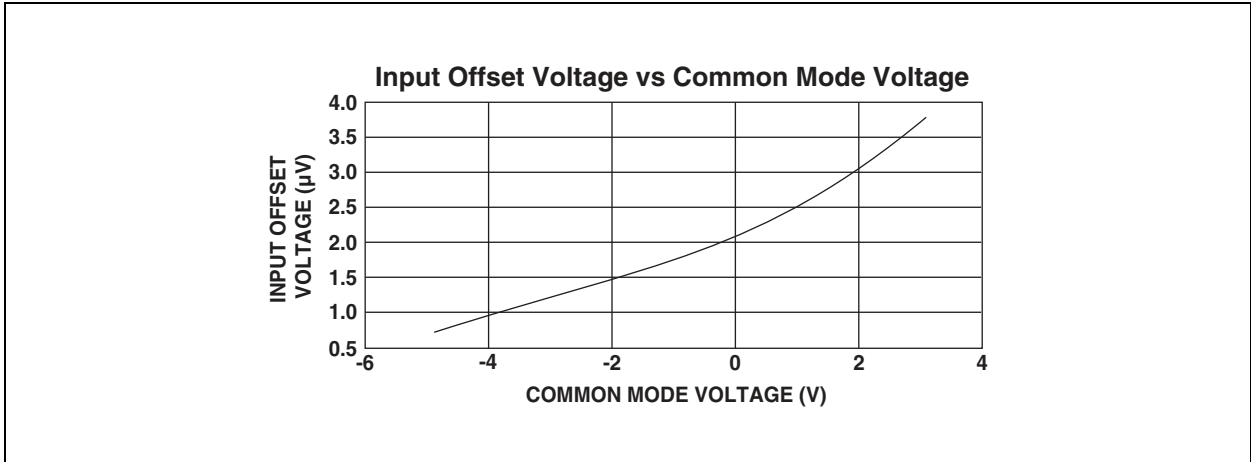

TC7652

6.0 PACKAGING INFORMATION

6.1 Package Marking Information

Package marking information not available at this time.

6.2 Package Dimensions

Note: For the most current package drawings, please see the Microchip Packaging Specification located at <http://www.microchip.com/packaging>

8-Pin Plastic DIP

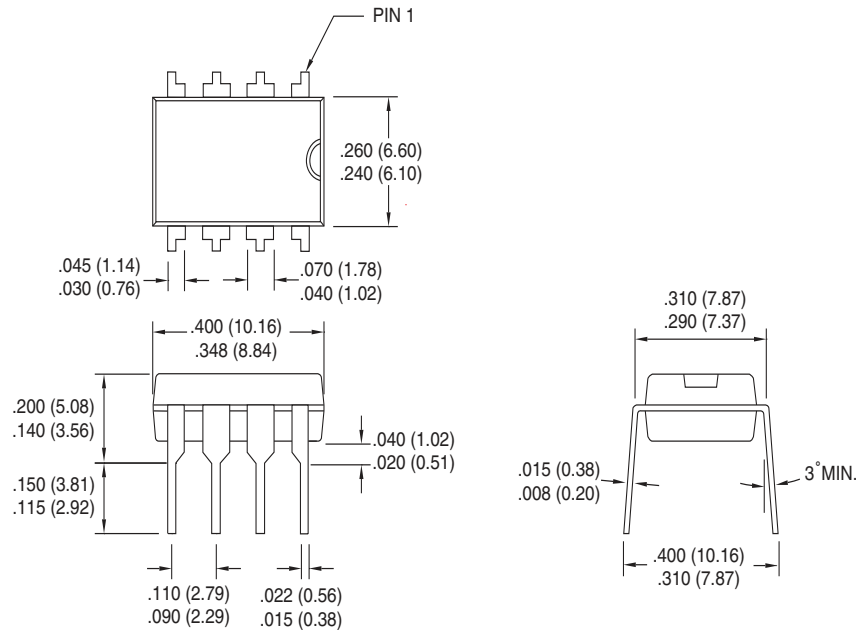

Dimensions: inches (mm)

Note: For the most current package drawings, please see the Microchip Packaging Specification located at <http://www.microchip.com/packaging>

14-Pin PDIP (Narrow)

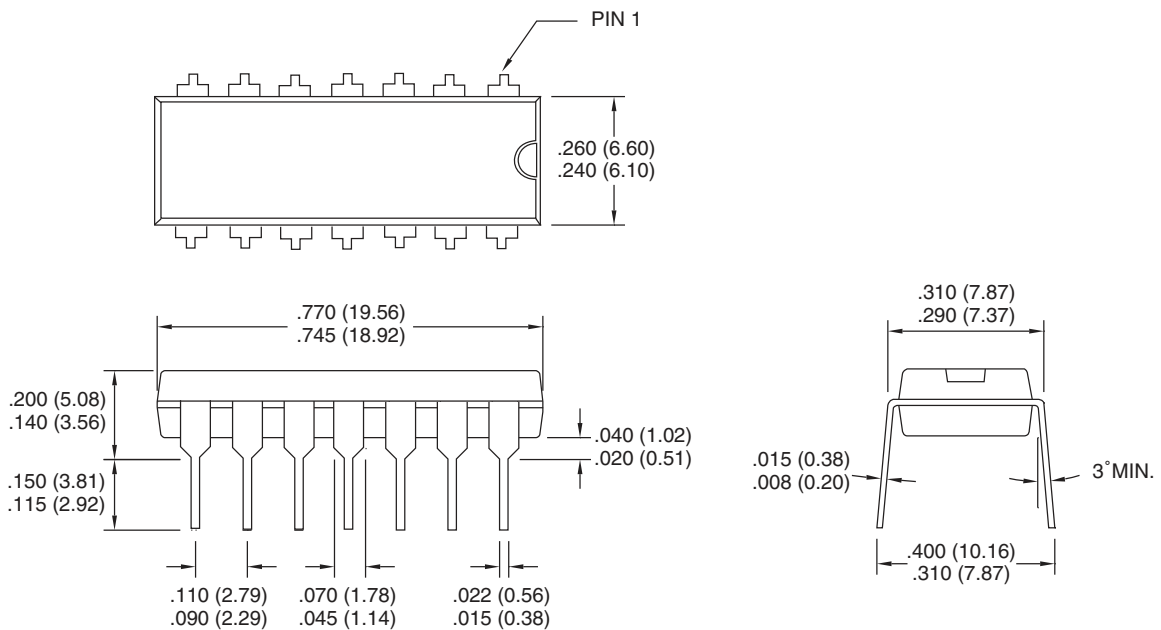

Dimensions: inches (mm)

7.0 REVISION HISTORY

Revision C (December 2012)

Added a note to each package outline drawing.

SALES AND SUPPORT

Data Sheets

Products supported by a preliminary Data Sheet may have an errata sheet describing minor operational differences and recommended workarounds. To determine if an errata sheet exists for a particular device, please contact one of the following:

1. Your local Microchip sales office
2. The Microchip Worldwide Site (www.microchip.com)

Please specify which device, revision of silicon and Data Sheet (include Literature #) you are using.

New Customer Notification System

Register on our web site (www.microchip.com/cn) to receive the most current information on our products.

TC7652

NOTES:

Note the following details of the code protection feature on Microchip devices:

- Microchip products meet the specification contained in their particular Microchip Data Sheet.
- Microchip believes that its family of products is one of the most secure families of its kind on the market today, when used in the intended manner and under normal conditions.
- There are dishonest and possibly illegal methods used to breach the code protection feature. All of these methods, to our knowledge, require using the Microchip products in a manner outside the operating specifications contained in Microchip's Data Sheets. Most likely, the person doing so is engaged in theft of intellectual property.
- Microchip is willing to work with the customer who is concerned about the integrity of their code.
- Neither Microchip nor any other semiconductor manufacturer can guarantee the security of their code. Code protection does not mean that we are guaranteeing the product as “unbreakable.”

Code protection is constantly evolving. We at Microchip are committed to continuously improving the code protection features of our products. Attempts to break Microchip's code protection feature may be a violation of the Digital Millennium Copyright Act. If such acts allow unauthorized access to your software or other copyrighted work, you may have a right to sue for relief under that Act.

Information contained in this publication regarding device applications and the like is provided only for your convenience and may be superseded by updates. It is your responsibility to ensure that your application meets with your specifications. MICROCHIP MAKES NO REPRESENTATIONS OR WARRANTIES OF ANY KIND WHETHER EXPRESS OR IMPLIED, WRITTEN OR ORAL, STATUTORY OR OTHERWISE, RELATED TO THE INFORMATION, INCLUDING BUT NOT LIMITED TO ITS CONDITION, QUALITY, PERFORMANCE, MERCHANTABILITY OR FITNESS FOR PURPOSE. Microchip disclaims all liability arising from this information and its use. Use of Microchip devices in life support and/or safety applications is entirely at the buyer's risk, and the buyer agrees to defend, indemnify and hold harmless Microchip from any and all damages, claims, suits, or expenses resulting from such use. No licenses are conveyed, implicitly or otherwise, under any Microchip intellectual property rights.

Trademarks

The Microchip name and logo, the Microchip logo, dsPIC, FlashFlex, KEELOQ, KEELOQ logo, MPLAB, PIC, PICmicro, PICSTART, PIC³² logo, rPIC, SST, SST Logo, SuperFlash and UNI/O are registered trademarks of Microchip Technology Incorporated in the U.S.A. and other countries.

FilterLab, Hampshire, HI-TECH C, Linear Active Thermistor, MTP, SEEVAL and The Embedded Control Solutions Company are registered trademarks of Microchip Technology Incorporated in the U.S.A.

Silicon Storage Technology is a registered trademark of Microchip Technology Inc. in other countries.

Analog-for-the-Digital Age, Application Maestro, BodyCom, chipKIT, chipKIT logo, CodeGuard, dsPICDEM, dsPICDEM.net, dsPICworks, dsSPEAK, ECAN, ECONOMONITOR, FanSense, HI-TIDE, In-Circuit Serial Programming, ICSP, Mindi, MiWi, MPASM, MPF, MPLAB Certified logo, MPLIB, MPLINK, mTouch, Omniclient Code Generation, PICC, PICC-18, PICDEM, PICDEM.net, PICkit, PICtail, REAL ICE, rLAB, Select Mode, SQI, Serial Quad I/O, Total Endurance, TSHARC, UniWinDriver, WiperLock, ZENA and Z-Scale are trademarks of Microchip Technology Incorporated in the U.S.A. and other countries.

SQTP is a service mark of Microchip Technology Incorporated in the U.S.A.

GestIC and ULPP are registered trademarks of Microchip Technology Germany II GmbH & Co. & KG, a subsidiary of Microchip Technology Inc., in other countries.

All other trademarks mentioned herein are property of their respective companies.

© 2001-2012, Microchip Technology Incorporated, Printed in the U.S.A., All Rights Reserved.

 Printed on recycled paper.

ISBN: 9781620768419

QUALITY MANAGEMENT SYSTEM
CERTIFIED BY DNV
== ISO/TS 16949 ==

Microchip received ISO/TS-16949:2009 certification for its worldwide headquarters, design and wafer fabrication facilities in Chandler and Tempe, Arizona; Gresham, Oregon and design centers in California and India. The Company's quality system processes and procedures are for its PIC[®] MCUs and dsPIC[®] DSCs, KEELOQ[®] code hopping devices, Serial EEPROMs, microperipherals, nonvolatile memory and analog products. In addition, Microchip's quality system for the design and manufacture of development systems is ISO 9001:2000 certified.



MICROCHIP

Worldwide Sales and Service

AMERICAS

Corporate Office
2355 West Chandler Blvd.
Chandler, AZ 85224-6199
Tel: 480-792-7200
Fax: 480-792-7277
Technical Support:
<http://www.microchip.com/support>
Web Address:
www.microchip.com

Atlanta
Duluth, GA
Tel: 678-957-9614
Fax: 678-957-1455

Boston
Westborough, MA
Tel: 774-760-0087
Fax: 774-760-0088

Chicago
Itasca, IL
Tel: 630-285-0071
Fax: 630-285-0075

Cleveland
Independence, OH
Tel: 216-447-0464
Fax: 216-447-0643

Dallas
Addison, TX
Tel: 972-818-7423
Fax: 972-818-2924

Detroit
Farmington Hills, MI
Tel: 248-538-2250
Fax: 248-538-2260

Indianapolis
Noblesville, IN
Tel: 317-773-8323
Fax: 317-773-5453

Los Angeles
Mission Viejo, CA
Tel: 949-462-9523
Fax: 949-462-9608

Santa Clara
Santa Clara, CA
Tel: 408-961-6444
Fax: 408-961-6445

Toronto
Mississauga, Ontario,
Canada
Tel: 905-673-0699
Fax: 905-673-6509

ASIA/PACIFIC

Asia Pacific Office
Suites 3707-14, 37th Floor
Tower 6, The Gateway
Harbour City, Kowloon
Hong Kong
Tel: 852-2401-1200
Fax: 852-2401-3431

Australia - Sydney
Tel: 61-2-9868-6733
Fax: 61-2-9868-6755

China - Beijing
Tel: 86-10-8569-7000
Fax: 86-10-8528-2104

China - Chengdu
Tel: 86-28-8665-5511
Fax: 86-28-8665-7889

China - Chongqing
Tel: 86-23-8980-9588
Fax: 86-23-8980-9500

China - Hangzhou
Tel: 86-571-2819-3187
Fax: 86-571-2819-3189

China - Hong Kong SAR
Tel: 852-2943-5100
Fax: 852-2401-3431

China - Nanjing
Tel: 86-25-8473-2460
Fax: 86-25-8473-2470

China - Qingdao
Tel: 86-532-8502-7355
Fax: 86-532-8502-7205

China - Shanghai
Tel: 86-21-5407-5533
Fax: 86-21-5407-5066

China - Shenyang
Tel: 86-24-2334-2829
Fax: 86-24-2334-2393

China - Shenzhen
Tel: 86-755-8864-2200
Fax: 86-755-8203-1760

China - Wuhan
Tel: 86-27-5980-5300
Fax: 86-27-5980-5118

China - Xian
Tel: 86-29-8833-7252
Fax: 86-29-8833-7256

China - Xiamen
Tel: 86-592-2388138
Fax: 86-592-2388130

China - Zhuhai
Tel: 86-756-3210040
Fax: 86-756-3210049

ASIA/PACIFIC

India - Bangalore
Tel: 91-80-3090-4444
Fax: 91-80-3090-4123

India - New Delhi
Tel: 91-11-4160-8631
Fax: 91-11-4160-8632

India - Pune
Tel: 91-20-2566-1512
Fax: 91-20-2566-1513

Japan - Osaka
Tel: 81-6-6152-7160
Fax: 81-6-6152-9310

Japan - Tokyo
Tel: 81-3-6880-3770
Fax: 81-3-6880-3771

Korea - Daegu
Tel: 82-53-744-4301
Fax: 82-53-744-4302

Korea - Seoul
Tel: 82-2-554-7200
Fax: 82-2-558-5932 or
82-2-558-5934

Malaysia - Kuala Lumpur
Tel: 60-3-6201-9857
Fax: 60-3-6201-9859

Malaysia - Penang
Tel: 60-4-227-8870
Fax: 60-4-227-4068

Philippines - Manila
Tel: 63-2-634-9065
Fax: 63-2-634-9069

Singapore
Tel: 65-6334-8870
Fax: 65-6334-8850

Taiwan - Hsin Chu
Tel: 886-3-5778-366
Fax: 886-3-5770-955

Taiwan - Kaohsiung
Tel: 886-7-213-7828
Fax: 886-7-330-9305

Taiwan - Taipei
Tel: 886-2-2508-8600
Fax: 886-2-2508-0102

Thailand - Bangkok
Tel: 66-2-694-1351
Fax: 66-2-694-1350

EUROPE

Austria - Wels
Tel: 43-7242-2244-39
Fax: 43-7242-2244-393

Denmark - Copenhagen
Tel: 45-4450-2828
Fax: 45-4485-2829

France - Paris
Tel: 33-1-69-53-63-20
Fax: 33-1-69-30-90-79

Germany - Munich
Tel: 49-89-627-144-0
Fax: 49-89-627-144-44

Italy - Milan
Tel: 39-0331-742611
Fax: 39-0331-466781

Netherlands - Drunen
Tel: 31-416-690399
Fax: 31-416-690340

Spain - Madrid
Tel: 34-91-708-08-90
Fax: 34-91-708-08-91

UK - Wokingham
Tel: 44-118-921-5869
Fax: 44-118-921-5820

11/29/12