

Powerex, Inc., 173 Pavilion Lane, Youngwood, Pennsylvania 15697 (724) 925-7272
<http://www.pwr.com>

POW-R-BLOK™
Dual SCR Isolated Module
90 Amperes / Up to 1800 Volts

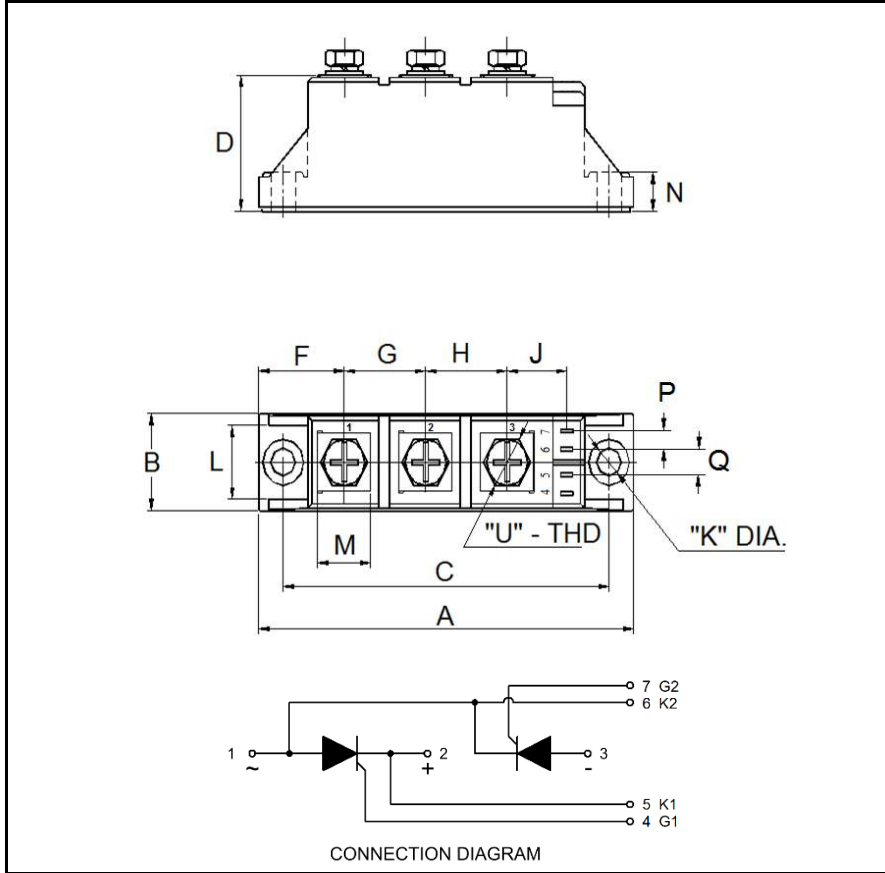

CD43_90C
Dual SCR Isolated
POW-R-BLOK™ Module
 90 Amperes / Up to 1800 Volts

Description:

Powerex Dual SCR Modules are designed for use in applications requiring phase control and isolated packaging. The modules are isolated for easy mounting with other components on a common heatsink.

Features:

- Electrically Isolated Heatsinking
- Compression Bonded for Increased Power Cycling Capability
- Low Thermal Impedance For Improved Current Capability
- RoHS Compliant
- UL Recognized (E78240)

Benefits:

- No Additional Insulation Components Required
- Easy Installation
- No Clamping Components Required
- Reduce Engineering Time

Applications:

- Bridge Circuits
- AC & DC Motor Drives
- Battery Supplies
- Power Supplies
- Large IGBT Circuit Front Ends
- Lighting Control
- Heat & Temperature Control
- Welders

CD43_90C Outline Dimensions

Dimension	Inches	Millimeters
A	3.62	92
B	0.83	21
C	3.15	80
D	1.18	30
F	0.83	21
G	0.79	20
H	0.79	20
J	0.57	14.5
K	0.24	6.2
L	0.63	16
M	0.51	13
N	0.33	8.5
P	0.16	4
Q	0.22	5.6
S	0.11 x .02	2.8 x 0.5
U	M5	M5

Note: Dimensions are for reference only.

Ordering Information:

Select the complete nine digit module part number from the table below.
 Example: CD431690C is a 1600Volt, 90 Ampere Dual SCR Isolated POW-R-BLOK™ Module

Type	Voltage Volts (x100)	Current Amperes	Version
CD43	08	90	C
	12		
	14		
	16		
18			

Absolute Maximum Ratings

Characteristics	Conditions	Symbol		Units
Repetitive Peak Forward and Reverse Blocking Voltage		V_{DRM} & V_{RRM}	up to 1800	V
Non-Repetitive Peak Reverse Blocking Voltage (t < 5 msec)		V_{RSM}	$V_{RRM} + 100$	V
RMS Forward Current	180° Conduction, $T_C=85^\circ\text{C}$	$I_{T(RMS)}$	141	A
Average Forward Current	180° Conduction, $T_C=85^\circ\text{C}$	$I_{T(AV)}$	90	A
Peak One Cycle Surge Current, Non-Repetitive	50 Hz, 60% V_{RRM} reapplied, $T_j=125^\circ\text{C}$	I_{TSM}	2000	A
I^2t for Fusing for One Cycle, 10 milliseconds	50 Hz, 60% V_{RRM} reapplied, $T_j=125^\circ\text{C}$	I^2t	20,400	A ² sec
Maximum Rate-of-Rise of On-State Current, (Repetitive)	$T_j=125^\circ\text{C}$	di/dt	100	A/ μs
Operating Temperature		T_J	-40 to +125	°C
Storage Temperature		T_{stg}	-40 to +125	°C
Max. Mounting Torque, M5 Mounting Screw on Terminals			35 4	in.-Lb. Nm
Max. Mounting Torque, Module to Heatsink			53 6	in.-Lb. Nm
Module Weight, Typical			160 5.64	g oz.
V Isolation @ 25C	50 – 60 Hz, 1 minute	V_{rms}	2500	V

Information presented is based upon manufacturers testing and projected capabilities.
This information is subject to change without notice.
The manufacturer makes no claim as to the suitability of use, reliability, capability,
or future availability of this product.

Electrical Characteristics, T_J=25°C unless otherwise specified

Characteristics	Symbol	Test Conditions	Min.	Max.	Units
Repetitive Peak Forward Leakage Current	I _{DRM}	Up to V _{DRM} , T _J =125°C		10	mA
Repetitive Peak Reverse Leakage Current	I _{RPM}	Up to V _{RPM} , T _J =125°C		10	mA
Peak On-State Voltage	V _{TM}	I _{TM} =270A		1.90	V
Threshold Voltage, Low-level	V _{(TO)1}	T _J = 125°C, I = 16.7% × πI _{T(AV)} to πI _{T(AV)}		0.8	V
Slope Resistance, Low-level	r _{T1}			3.01	mΩ
Minimum dV/dt	dV/dt	T _J =125°C, V _{DM} = 0.67 V _{DRM}	800		V/μs
Gate Trigger Current	I _{GT}	T _J = 25°C, V _D =12V, I _A = 1 A	30	100	mA
Gate Trigger Voltage	V _{GT}	T _J = 25°C, V _D =12V, I _A = 1 A	0.75	2.5	Volts
Holding Current	I _H	T _J = 25°C, V _D =12V, I _A = 1 A	20	100	mA

Thermal Characteristics

Characteristics	Symbol		Max.	Units
Thermal Resistance, Junction to Case DC Operation	R _{ΘJ-C}	Per Junction, both conducting	0.28	°C/W
Thermal Resistance, Case to Sink Lubricated	R _{ΘC-S}	Per Module	0.15	°C/W

Maximum On-State Forward Voltage Drop
 (T_j = 125 °C)

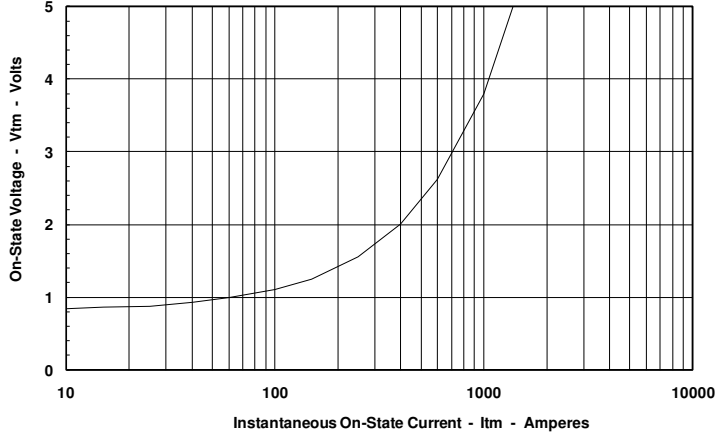

Maximum Transient Thermal Impedance
 (Junction to Case)

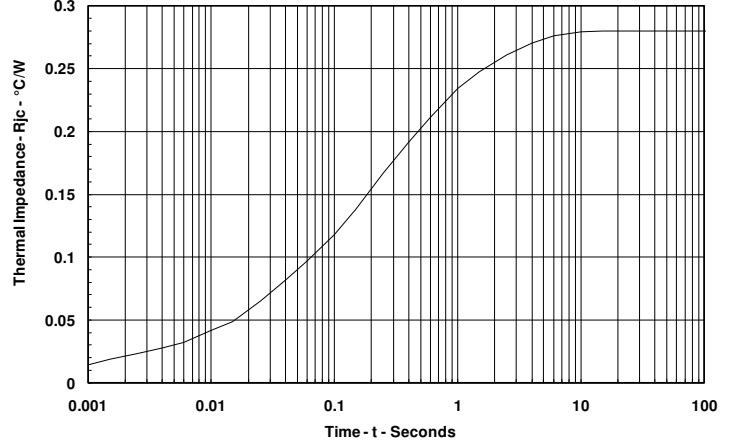

Maximum On-State Power Dissipation
 (Sinusoidal Waveform)

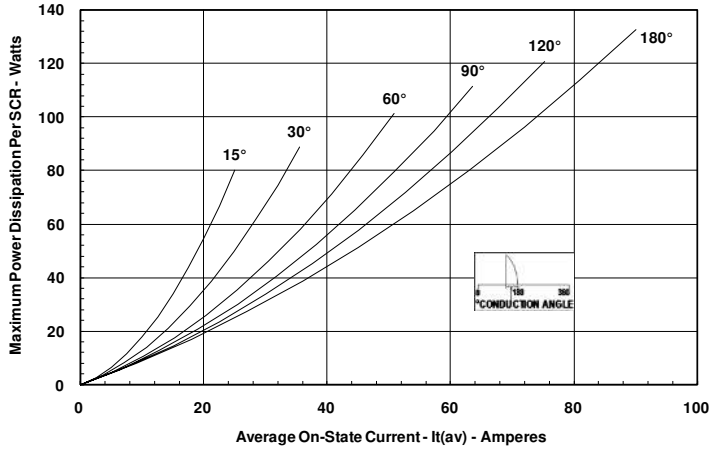

Maximum Allowable Case Temperature
 (Sinusoidal Waveform)

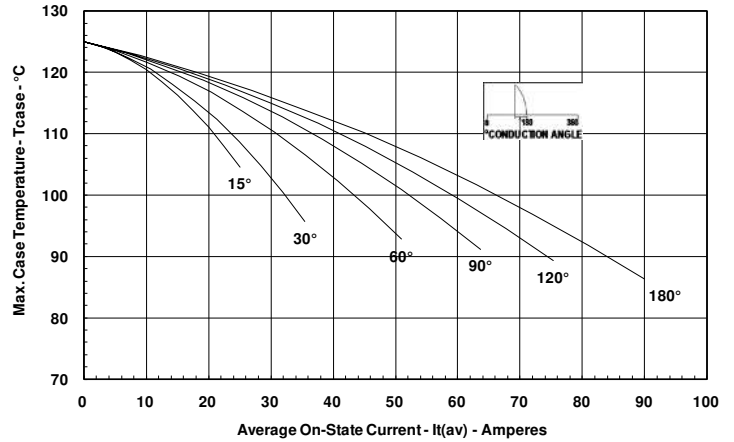

Maximum On-State Power Dissipation
 (Rectangular Waveform)

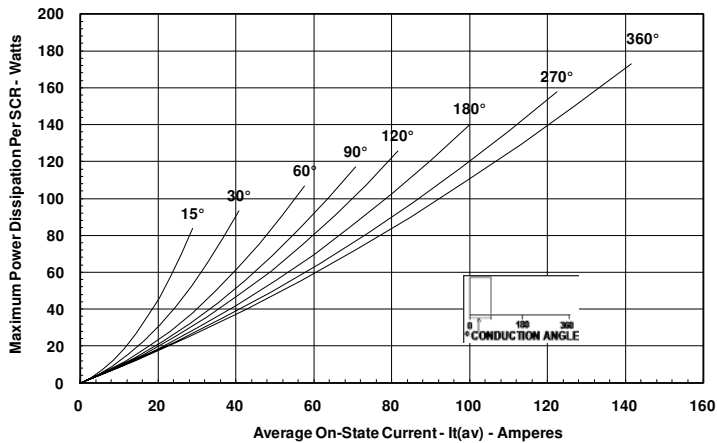

Maximum Allowable Case Temperature
 (Rectangular Waveform)

