

OH020-61003CV-010.0M 20x20mm VCOCXO

CONNOR WINFIELD



VCOCXO

2111 Comprehensive Drive
Aurora, Illinois 60505
Phone: 630-851-4722
Fax: 630-851-5040
www.conwin.com

Description:

The Connor-Winfield OH020-61003CV-010.0M is a 20x20mm through-hole VCOCXO in a 5-pin metal package.



Features:

- VCOCXO
- 3.3Vdc Operation
- 20 x 20mm Metal Package
- Frequency Stability ± 10 ppb
- Temperature Range -40°C to 85°C
- LVCMOS Output
- RoHS Compliant / Lead Free

Package Dimensions

Symbol	Dimensions (mm)	
	Min	Max
A		20.6
B	14.74	15.74
C		12
D	0.4	0.6
E	4.0	5.0
F	0.5	0.7
G	7.52	7.72
H	10.1 nominal	
I	10.1 nominal	

Package Outline

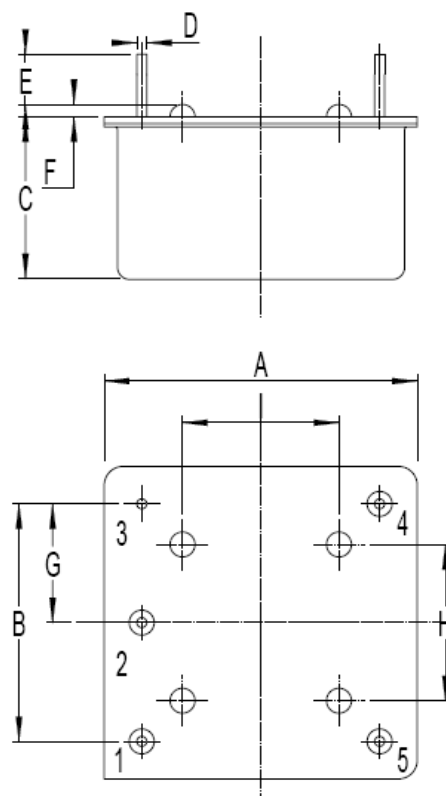

Marking Configuration

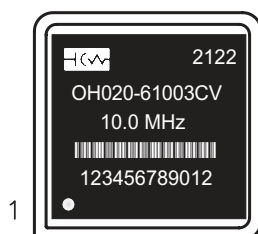

2122 Date Code (YYWW)
OH020-61003CV Model Number
10.0 MHz Output Frequency
123456789012 Serial # Barcode
123456789012 Serial Number

Pin Connections

- 1: Supply Voltage (Vdd)
- 2: Output
- 3: Ground
- 4: Voltage Control
- 5: N/C

Ordering Information

OH020-61003CV-010.0M



Bulletin **Cx317**
Page **1 of 4**
Revision **00**
Date **19 Nov 2021**



Attention: System Designers please review Application Note AN2093:
System Design Information and Printed Circuit Board Layout Guidelines for OCXO Oscillators.
@ www.conwin.com/technologies.html



Absolute Maximum Ratings

Parameter	Minimum	Nominal	Maximum	Units	Notes
Storage Temperature	-40	-	105	°C	
Supply Voltage (Vdd)	-0.5	-	6.0	Vdc	
Control Voltage (Vc)	-0.5	-	6.0	Vdc	

Operating Specifications

Parameter	Minimum	Nominal	Maximum	Units	Notes
Center Frequency: (Fo)	-	10	-	MHz	
Frequency Calibration	-100	-	100	ppb	1
Frequency Stability vs Temperature	-10	-	10	ppb	2
vs. Supply Voltage Change	-0.5	-	0.5	ppb	Vcc ±5%
vs. Load Change	-0.5	-	0.5	ppb	Load ±5%
vs. Aging per day	-0.5	-	0.5	ppb	3
vs. Aging 1st Year	-50	-	50	ppb	
vs Aging 10 Years	-2.0	-	2.0	ppm	
Operating Temperature Range	-40	-	85	°C	4
Warm-up Time at 25°C	-	-	5	Minutes	5
Short Term Stability (ADEV at 1s)	-	-	1.0E-11		6

Phase Noise

Parameter	Minimum	Nominal	Maximum	Units	Notes
@ 1Hz offset	-	-	-95	dBc/Hz	
@ 10Hz offset	-	-	-120	dBc/Hz	
@ 100Hz offset	-	-	-140	dBc/Hz	
@ 1KHz offset	-	-	-150	dBc/Hz	
@ 10KHz offset	-	-	-155	dBc/Hz	
@ 100KHz offset	-	-	-150	dBc/Hz	

Supply Voltage (Vdd)

Parameter	Minimum	Nominal	Maximum	Units	Notes
Supply Voltage:	3.13	3.30	3.47	Vdc	
Power Consumption					
Turn On	-	-	4.0	W	
Steady State at 25°C	-	-	1.5	W	

Input Characteristics - Voltage Control (Vc)

Parameter	Minimum	Nominal	Maximum	Units	Notes
Tuning Range	±0.5	-	±1.0	ppm	
Linearity	-	-	10	%	
Control Voltage Range	0.0	1.65	3.3	Vdc	
Tuning Slope		Positive			
Linearity	-	-	10	%	
Input Impedance	100K	-	-	Ohms	

CMOS Output Characteristics

Parameter	Minimum	Nominal	Maximum	Units	Notes
Load	-	15	-	pF	
Output Voltage: High (Voh)	3.0	-	-	V	
Low (Vol)	-	-	0.4	V	
Output Current: High (Ioh)	-4	-	-	mA	
Low (Iol)	-	-	4	mA	
Duty Cycle at 50% of Vcc	45	50	55	%	
Rise / Fall Time: 10% to 90%	-	-	6	ns	

Package Characteristics

OH020-Series Package Hermetically sealed, resistive welded package with grounded case.

Environmental Characteristics

Shock	500 G's 1ms, Halfsine, 3 shocks per direction, per MIL-STD 202F, Method 213B Test Condition D.
Sinusoidal Vibration	0.06" D.A. or 10G's Peak, 10 to 500 Hz, per MIL-STD-202F, Method 204D, Test Condition A.
Random Vibration	5.35 G's rms. 20 to 2000 Hz per MIL-STD-202F, Method 214, Test Condition 1A, 15 minutes each axis.
Moisture	10 cycles, 95% RH, Per MIL-STD-202F, Method 112.
Marking Permanency	Per MIL-STD-202F, Method 215J.
Attachment Method PCB	Through Hole Mounted
Resistance to Solder Heat	Per MIL-STD-202F, Method 210, Condition E.
Solder Process	RoHS compliant, lead free. See solder profile.

Notes:

1. At time of shipment after 60 minutes of operation @ 25°C with nominal control voltage and supply voltage values.
2. Frequency stability vs. change in temperature $[\pm(F_{max}-F_{min})/(2 \cdot F_0)]$.
3. At time of shipment after 48 hours of operation.
4. Other temperature ranges available upon request.
5. Measured at 25°C, the frequency observed after 5min will be within ± 100 ppb of the frequency observed after 60 minutes.
6. The part is shielded from airflow during this measurement.

Typical Phase Noise

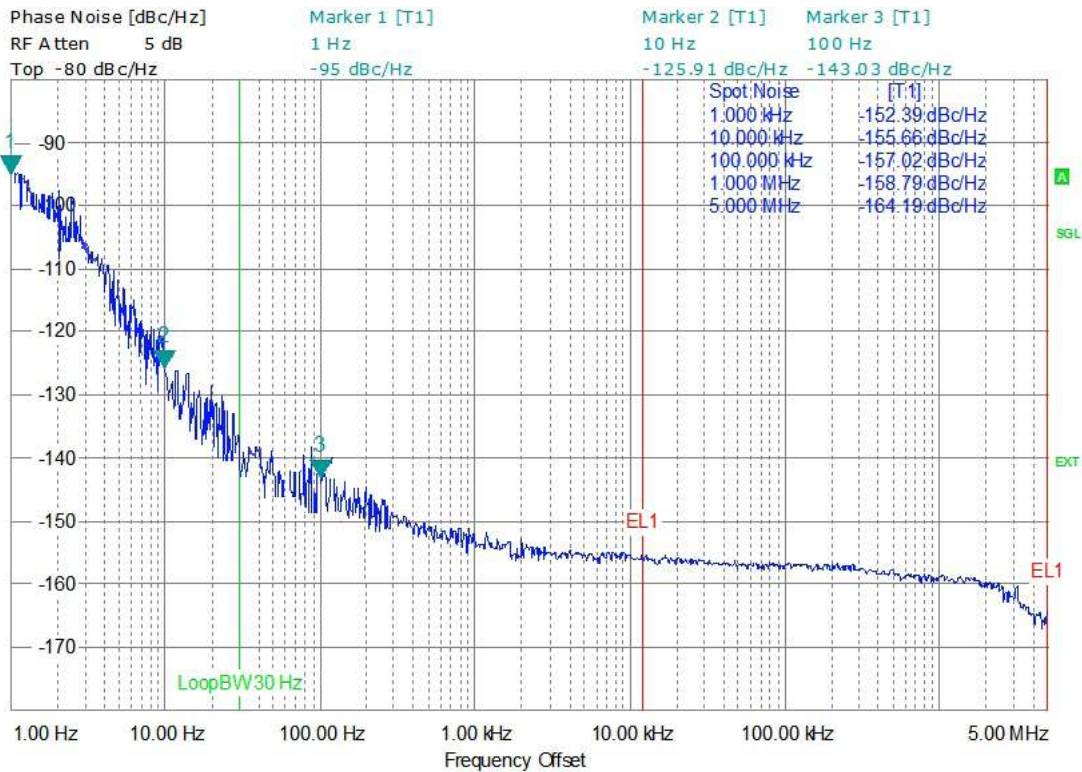

Solder Profile

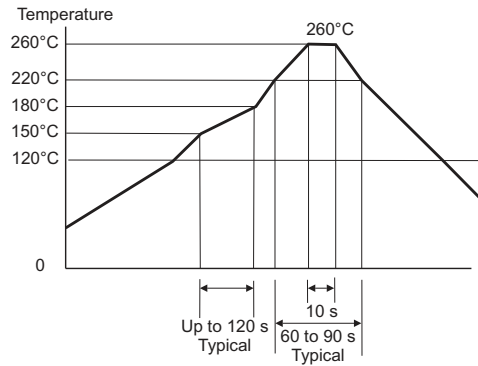

Meets IPC/JEDEC J-STD-020C

Test Circuit

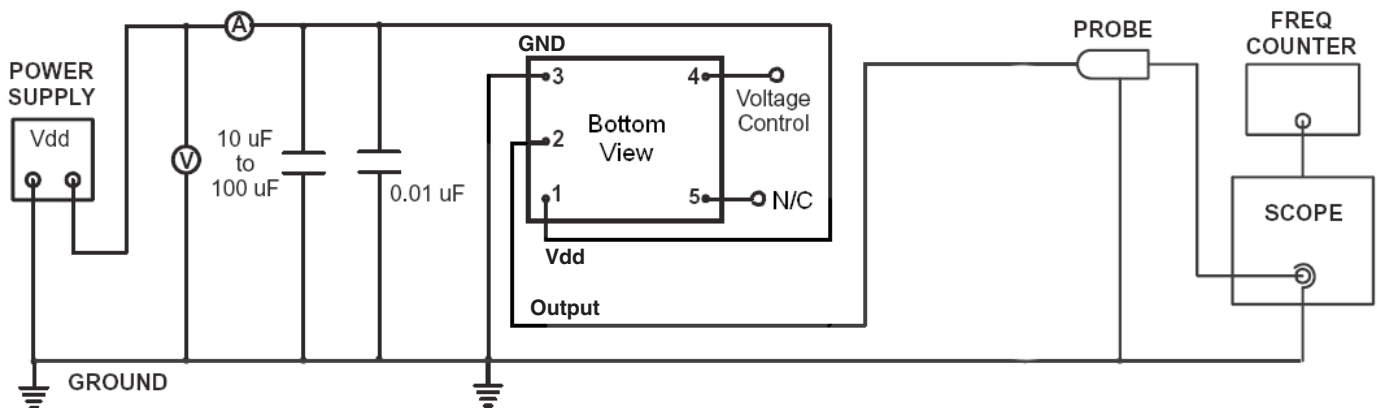

Revision History

Revision	Date	Description
00	11/19/21	New issue

Bulletin	Cx317
Page	4 of 4
Revision	00
Date	19 Nov 2021