

LOC	DIST	P	F	ZONE	LTR	REVISIONS	DATE	APPD	
GP	00					M	REVISED PER EC 0513-0300-04	24SEP04	JG

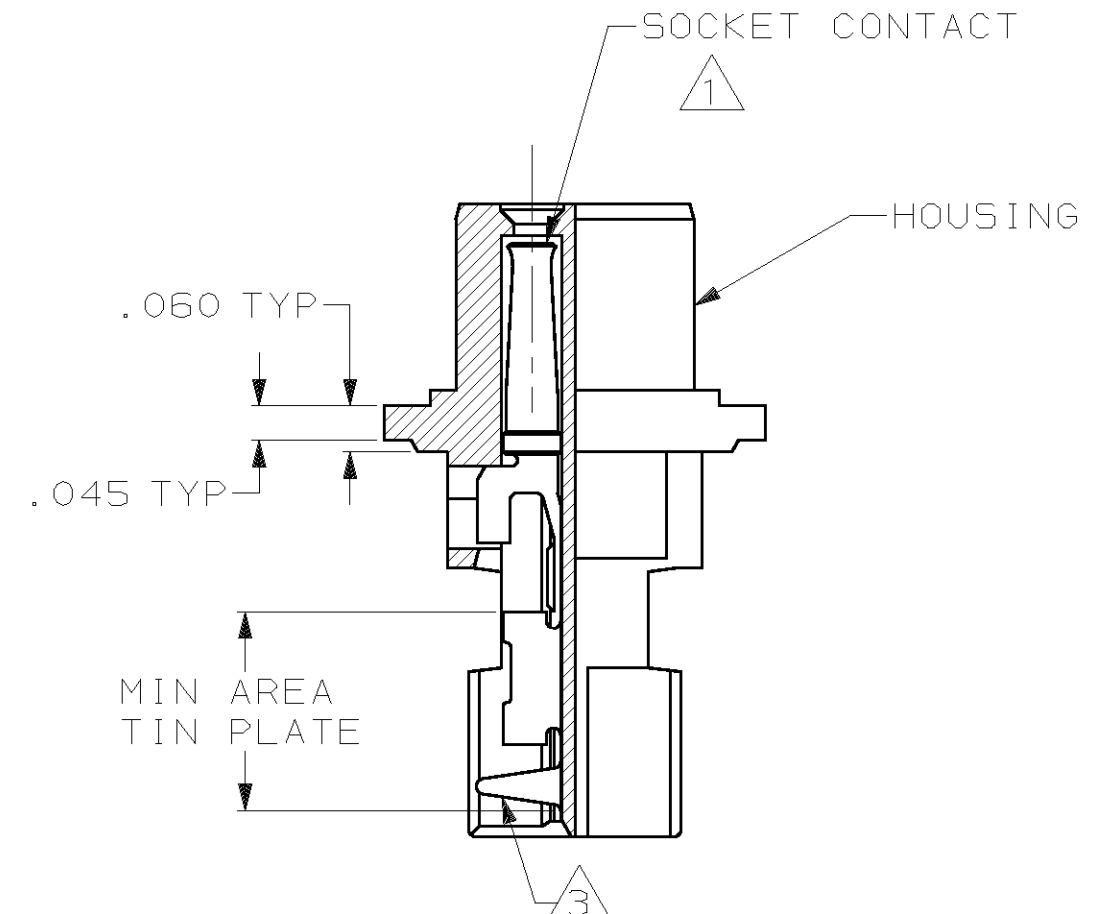
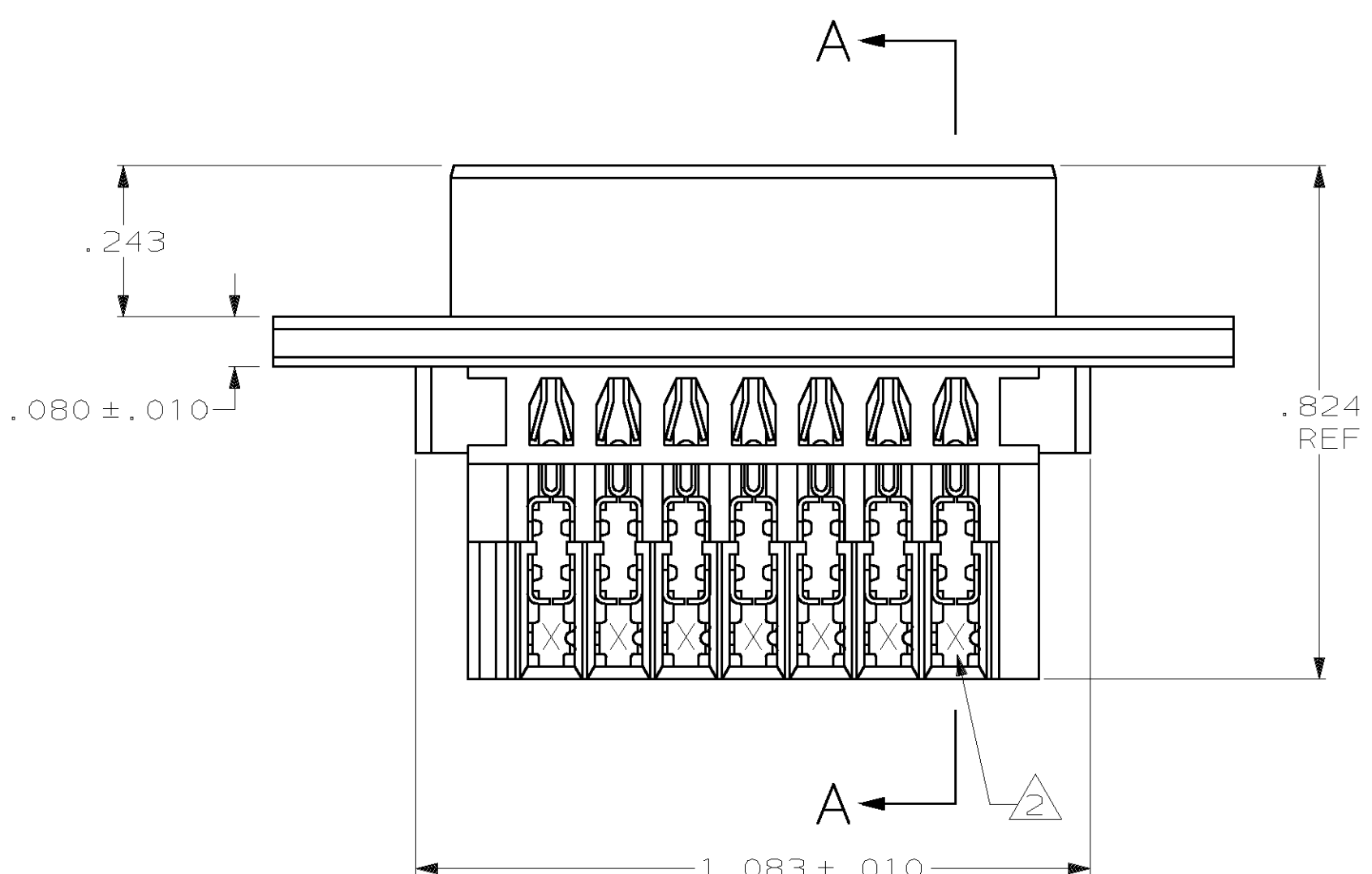
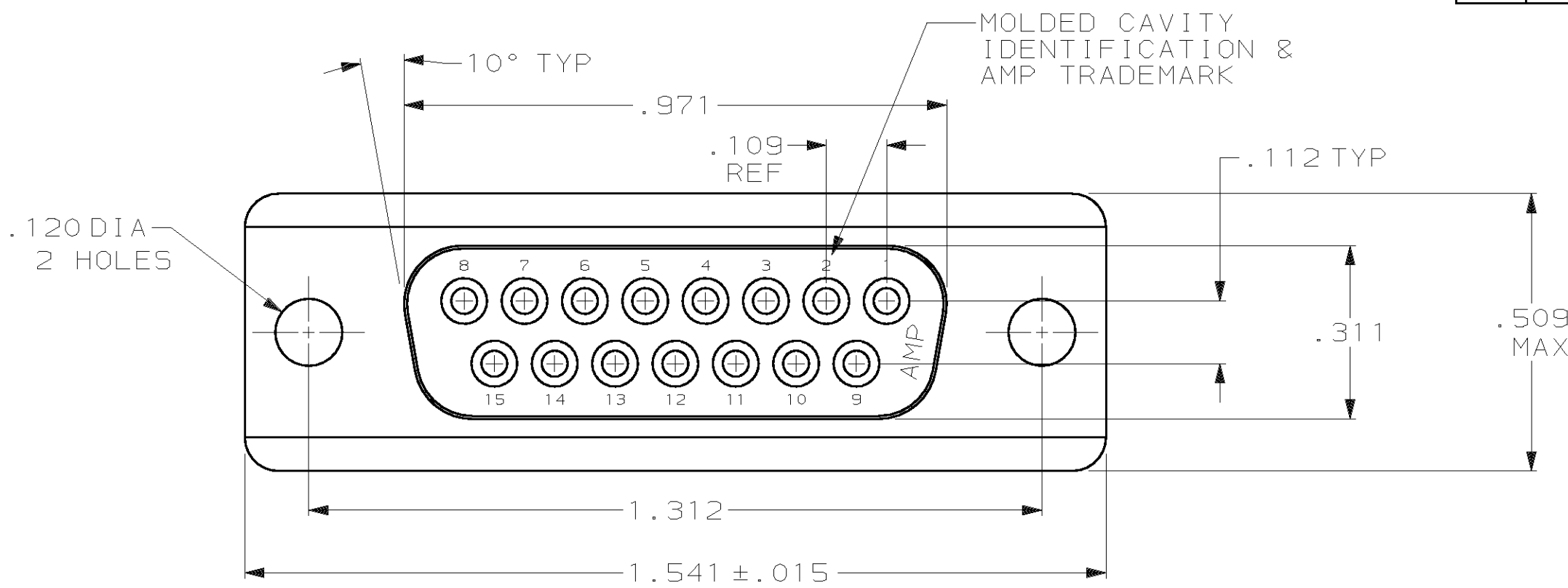

SECTION A-A

- ① HOUSING FULLY LOADED WITH CONTACTS.
- ② NUMBER ON CONTACT INDICATES WIRE RANGE.
- ③ CONTACT INSULATION RANGE: .060 MAXIMUM O.D.
- ④ CONTACTS PLATED .000030 GOLD ON MATING END FOR .100 MIN LENGTH. .000100-.000200 THICK BRIGHT TIN OR BRIGHT TIN-LEAD IN AREA SHOWN. .000050 THICK NICKEL UNDERPLATE ON ENTIRE CONTACT.
- ⑤ CONTACTS PLATED WITH GOLD FLASH ON MATING END FOR .100 MIN LENGTH. .000100-.000200 THICK BRIGHT TIN OR BRIGHT TIN-LEAD IN AREA SHOWN. .000030 THICK NICKEL UNDERPLATE ON ENTIRE CONTACT.
- ⑥ CONTACTS PLATED .000030 GOLD ON MATING END FOR .100 MIN LENGTH .000100-.000200 THICK MATTE TIN IN AREA SHOWN. .000050 THICK NICKEL UNDERPLATE ON ENTIRE CONTACT.
- ⑦ CONTACTS PLATED WITH GOLD FLASH ON MATING END FOR .100 MIN LENGTH. .000100-.000200 THICK BRIGHT TIN IN AREA SHOWN. .000030 THICK NICKEL UNDERPLATE ON ENTIRE CONTACT.

OBSOLETE	⑦	2	#22-26	745205-8
	⑥	2	#22-26	745205-7
OBSOLETE		3	#20-22	745205-6
OBSOLETE	⑤	2	#22-26	745205-5
OBSOLETE		1	#26-30	745205-4
OBSOLETE		3	#20-22	745205-3
	④	2	#22-26	745205-2
OBSOLETE		1	#26-30	745205-1
	FINISH	②	AWG WIRE RANGE	PART NUMBER

DO NOT SCALE PRINT. UNLESS SPECIFIED DIMENSIONS IN INCHES TOLERANCES ON : 2 PLC DEC ± - 3 PLC DEC ± .005 ANGLES ± 2°	DR 4-9-90 J GALLUCCI BG CHK 6-21-90 W.LENKER APPD 6-22-90 J.WESTMAN APPD 6-22-90 J.ASSINI	AMP AMP INCORPORATED Harrisburg, Pa. 17105	
MATERIAL HOUSING: BLACK THERMOPLASTIC 94V-0 RATED CONTACTS:PHOSPHOR BRONZE	PRODUCT SPEC 108-40011	RECEPTACLE ASSEMBLY, SIZE 2, 15 POSITION, AMPLIMITE™	
FINISH SEE TABLE	APPLICATION SPEC 114-40002	SIZE C	FSCM NO 00779
	WEIGHT -	SCALE 4:1	DRAWING NO 745205
			SHEET 1 OF 1