

REVISION(S)			
LTR	DESCRIPTION	INIT	APP'D
O	ECN: 0S60-0033-04	E.T 02/05/04	B.P 02/05/04
A	ECN: 0S60-0068-04	E.T 03/24/04	B.P 04/05/04
B	ECN: 0S60-0057-05	E.T 2/25/05	B.P 6/15/05
C	ECR-06-017841	E.T 8/25/06	V.K 8/25/06
D	OBSOLETE	*	*
E	ECO-11-005615	BM 3-17-11	WA 3-17-11

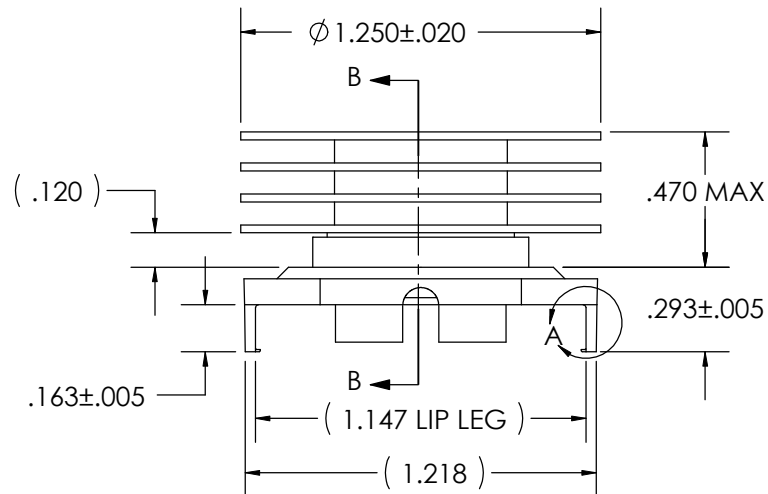

3/4 - 27 UNS -2A  
THREAD

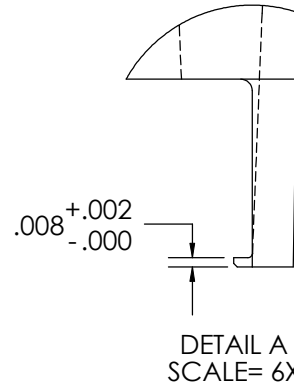
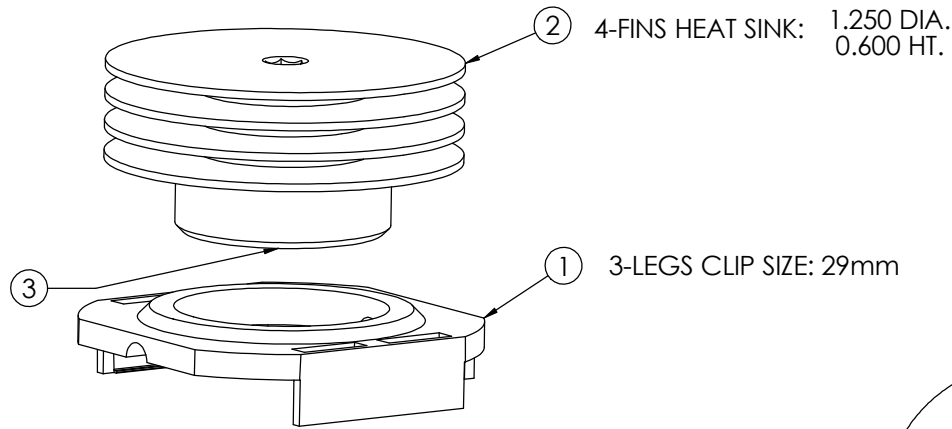
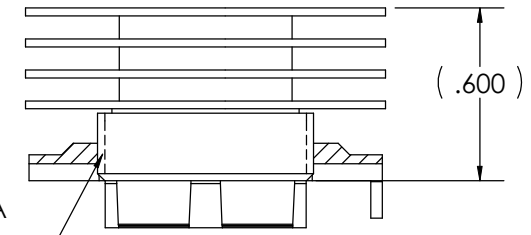

SECTION B-B

- MATERIAL:  
HEAT SINK: ALUM. (BLACK ANODIZE)  
CLIP: BLACK PEI (UL94-VO)
- BEFORE THE HEATSINK APPLICATION, THE USER SHOULD IDENTIFY THE SPECIFICATION OF MAXIMUM LOAD ON THE BGA PACKAGE.  
  
HEATSINK TORQUE SPECIFICATIONS CONVERTED TO FORCE.  
  
BARE DIE PACKAGE:  
1.5 POUND-FORCE INCH TORQUE = 7.5 POUND-FORCE  
(0.17 NEWTON TORQUE = 33.36 NEWTON)  
  
2.0 POUND-FORCE INCH TORQUE = 10.0 POUND-FORCE  
(0.23 NEWTON METER TORQUE = 44.48 NEWTON)  
  
FULL SIZE LID PACKAGE:  
1.5 POUND-FORCE INCH TORQUE = 6.9 POUND-FORCE  
(0.17 NEWTON TORQUE = 30.69 NEWTON)  
  
2.0 POUND-FORCE INCH TORQUE = 9.3 POUND-FORCE  
(0.23 NEWTON METER TORQUE = 41.37 NEWTON)
- REMOVE CLIP WITH REMOVAL TOOL P/N: 1542616-1.
- RoHS COMPLIANT AND CERTIFIED.

Power	°C/W @ Ambient	°C/W @ 200 LFM	°C/W @ 400 LFM	°C/W @ 600 LFM
5 Watts	12.19	5.49	3.85	2.95
10 Watts	11.04	5.47	3.76	2.82
15 Watts	10.07	5.35	3.67	2.82

**CUSTOMER DRAWING**  
SPECIFICATIONS ARE SUBJECT TO CHANGE WITHOUT NOTICE

ITEM	DESCRIPTION	QTY
1	MOUNTING CLIP	1
2	HEAT SINK	1
3	INTERFACE	1

**DO NOT SCALE**

**STE** TE Connectivity Norwood, Massachusetts 02062

UNLESS OTHERWISE SPECIFIED TOLERANCES ARE:  
.XX ± .  
.XXX ± .  
.XXXX ± .  
ANGLES ± \*

DRAWN BY: E.TAO	DATE: 01/13/04	MATERIAL: SEE NOTE
ENGINEER: B.P	DATE: 02/05/04	FINISH: SEE NOTE
FILENAME	PROJECT	SYSTEM

CONFIDENTIAL PROPERTY OF TE CONNECTIVITY. NOT TO BE DISCLOSED TO OTHERS. REPRODUCED OR USED FOR ANY PURPOSES EXCEPT AS AUTHORIZED IN WRITING BY AN AUTHORIZED OFFICIAL OF TE. MUST BE RETURNED TO TE ON DEMAND, ON COMPLETION OF ORDERS OR OTHER PURPOSES FOR WHICH LENT.

TITLE: **29mm HEATSINK ASSEMBLY**

DIMENSIONS ARE IN: INCHES	SCALE: 1.5:1	PART NO: <b>1542009-2</b>	SHEET: 1 OF 1
THIRD ANGLE PROJECTION	SIZE: <b>A</b>	DWG. NO. <b>C-1542009-2</b>	REV: <b>E</b>