

SPECIFICATION CONTROL DRAWING

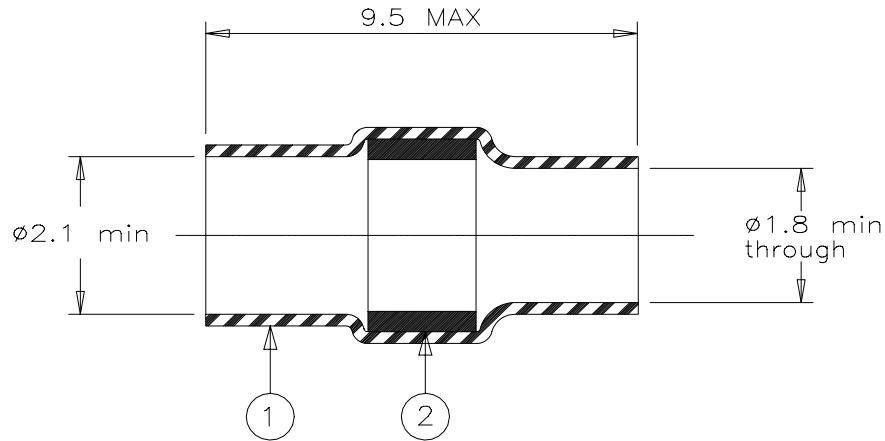

MATERIAL

1. INSULATION SLEEVE: Heat-shrinkable, radiation cross-linked modified polyvinylidene fluoride. Transparent blue.
2. SOLDER PREFORM WITH FLUX:
 SOLDER: TYPE Pb36 per ANSI J-STD-006.
 FLUX: TYPE ROL1 per ANSI J-STD-004.

APPLICATION

1. This controlled soldering device is designed for termination of a tin or silver plated copper stranded wire, having an insulation rated for at least +125°C, on to a post.
2. Temperature range: -55°C to +150°C.
3. For application tooling, consult your local RAYCHEM technical service.

For best results, prepare the cable as shown:

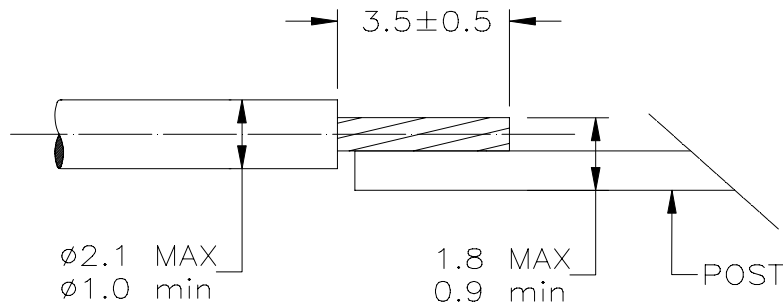

*A trademark of Raychem Corporation.

Raychem		THERMOFIT DEVICES	Raychem Corporation 300 Constitution Drive Menlo Park, CA 94025 USA	TITLE: SOLDERSLEEVE* DEVICE			
UNLESS OTHERWISE SPECIFIED DIMENSIONS ARE IN MILLIMETERS.				DOCUMENT NO.: W-040-10			
TOLERANCES: 0.00 N/A 0.0 N/A 0 N/A	ANGLES: N/A ROUGHNESS IN MICRON	Raychem reserves the right to amend this drawing at any time. Users should evaluate the suitability of the product for their application.		DCR NUMBER: D981084		REPLACES: W04010	
DRAWN BY: R. MAPALO	DATE: 06-29-98	REV.: C	DOC ISSUE: 1	SCALE: NONE	SIZE: A	SHEET: 1 of 1	

If this document is printed it becomes uncontrolled. Check for the latest revision