

RoHS **SL1026 Series Gas Plasma Arrester**



Agency Approvals

AGENCY	AGENCY FILE NUMBER
	E128662

3 Electrode GDT Graphical Symbol

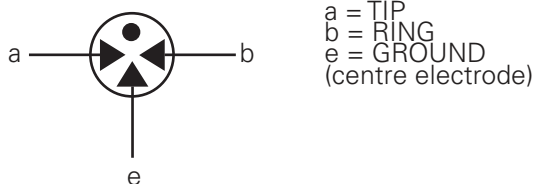

Description

The SL1026 Series is a heavy-duty transient suppressor using Gas Plasma technology. In response to transients that exceed the device's breakover voltage, the device changes from a very high impedance state to a low impedance state to conduct harmful current away from the protected system. The SL1026 is designed to protect electrical and electronic equipment such as communications, control and railway systems. Carefully designed geometry ensures against short circuiting if a failure occurs due to conditions and events beyond the design criteria. Optional electrical mounting clip (part SL1053) is available to aid mounting and connection.

Features

- RoHS compliant
- 55 kA surge capability (single shot) tested with 8/20µS pulse as defined by IEC 61000-4-5
- 40 kA surge capability (repetitive)
- Will protect against Trapezoidal waveforms as specified in RIA 12.
- Will protect against capacitor discharge voltage transient waveforms as specified in RIA 12.
- Will protect against double exponential voltage transient waveforms as specified in IEC 571.

Applications

- Signaling equipment.
- Communication equipment
- Control gear.
- Trackside cabinets.
- Cell phone base stations

Electrical Characteristics

Part Number*	DC Voltage 100 V/sec		DC Voltage 1kV/µs	¹ AC Current 9 cycles @ 50-60Hz (Amps)	¹ AC Current 50Hz 1 sec x10 (Amps)	¹ Surge Current 8/20µSec x 10 (kAmps)	^{1,2} Max Single Surge 8/20µSec (kAmps)	¹ Max Single Surge 10/350µSec (kAmps)	¹ 150(+) and 150(-) 10/1000µSec (Amps)
	MIN	MAX							
SL1026-275	200	350	800	200	10	20	40	8	200
SL1026-400	300	500	900	200	10	20	40	8	200
SL1026-700	560	840	1300	200	10	20	40	8	200

NOTES:

- End of life limits
- DC: 50% of minimum initial DC breakdown voltage limit to 150% of maximum initial DC breakdown voltage limit.
- Impulse: less than 150% of initial impulse breakdown voltage limit.
- 1. Total current through center electrode, tested using SL1053B-NL holder
- 2. Exceeds capability of SL1053B-NL holder

Voltage vs. Time Characteristic

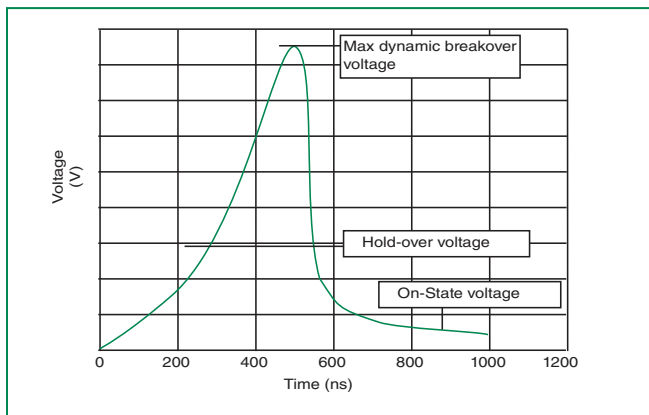

Electrical Specifications

Insulation Resistance	> 10GΩ at 100 Volts
Capacitance:	<=2.5pf, 1MHz 0 Volts Bias
Holdover Voltage:	<150mS, tested at 130 volts according to ITU-T Rec. K.12 & REA PE 80
Arc Voltage:	~35 Volts, On State Voltage at 1 Amp (Depending on Voltage Type)
Glow to Arc Transition Current:	~1 Amp
Glow Voltage:	> 150 Volts, depending on Voltage Type

Physical Specifications

Weight:	11g (0.388 oz.)
Materials:	Electrode Base: Nickel Iron Alloy Electrode Plating: Nickel Body: Ceramic
Part Marking:	Color coded body SL1026-275: Black/Black SL1026-400: Black/Yellow SL1026-700: Black/Red
Storage and Operating Temperature:	-40°C to +90°C

Product Dimensions

SL1026 GDT Series Profile

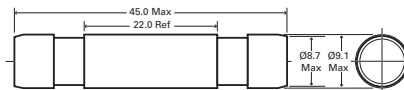

Type 1053 Holder Profile

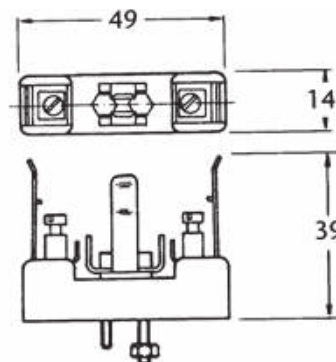

All dimensions in mm

Part Numbering System

SL 1026 | □ | □ | □ | □ | □
Voltage ————┐

Packaging

GDT devices are provided as bulk pack in poly bag – 20 pieces per bag and 5 bags per carton.