

The MPC92429 is a 3.3 V compatible, PLL based clock synthesizer targeted for high performance clock generation in mid-range to high-performance telecom, networking and computing applications. With output frequencies from 25 MHz to 400 MHz and the support of differential PECL output signals the device meets the needs of the most demanding clock applications.

Features

- 25 MHz to 400 MHz synthesized clock output signal
- Differential PECL output
- LVCMOS compatible control inputs
- On-chip crystal oscillator for reference frequency generation
- 3.3 V power supply
- Fully integrated PLL
- Minimal frequency overshoot
- Serial 3-wire programming interface
- Parallel programming interface for power-up
- 32-lead LQFP and 28-PLCC packaging
- 32-lead and 28-lead Pb-free package available
- SiGe Technology
- Ambient temperature range 0°C to +70°C
- Pin and function compatible to the MC12429 and MPC9229
- **Use replacement part: ICS84329B**

The internal crystal oscillator uses the external quartz crystal as the basis of its frequency reference. The frequency of the internal crystal oscillator is divided by 16 and then multiplied by the PLL. The VCO within the PLL operates over a range of 800 to 1600 MHz. Its output is scaled by a divider that is configured by either the serial or parallel interfaces. The crystal oscillator frequency f_{XTAL} , the PLL feedback-divider M and the PLL post-divider N determine the output frequency.

The feedback path of the PLL is internal. The PLL adjusts the VCO output frequency to be 4 x M times the reference frequency by adjusting the VCO control voltage. Note that for some values of M (either too high or too low) the PLL will not achieve phase lock. The PLL will be stable if the VCO frequency is within the specified VCO frequency range (800 to 1600 MHz). The M-value must be programmed by the serial or parallel interface.

The PLL post-divider N is configured through either the serial or the parallel interfaces, and can provide one of four division ratios (1, 2, 4, or 8). This divider extends performance of the part while providing a 50% duty cycle. The output driver is driven differentially from the output divider, and is capable of driving a pair of transmission lines terminated 50 Ω to $V_{CC} - 2.0$ V. The positive supply voltage for the internal PLL is separated from the power supply for the core logic and output drivers to minimize noise induced jitter.

The configuration logic has two sections: serial and parallel. The parallel interface uses the values at the M[8:0] and N[1:0] inputs to configure the internal counters. It is recommended on system reset to hold the P_LOAD input LOW until power becomes valid. On the LOW-to-HIGH transition of P_LOAD, the parallel inputs are captured. The parallel interface has priority over the serial interface. Internal pullup resistors are provided on the M[8:0] and N[1:0] inputs prevent the LVCMOS compatible control inputs from floating.

The serial interface centers on a fourteen bit shift register. The shift register shifts once per rising edge of the S_CLOCK input. The serial input S_DATA must meet setup and hold timing as specified in the AC Characteristics section of this document. The configuration latches will capture the value of the shift register on the HIGH-to-LOW edge of the S_LOAD input. See PROGRAMMING INTERFACE for more information. The TEST output reflects various internal node values, and is controlled by the T[2:0] bits in the serial data stream. In order to minimize the PLL jitter, it is recommended to avoid active signal on the TEST output.

MPC92429

400 MHZ LOW VOLTAGE CLOCK SYNTHESIZER

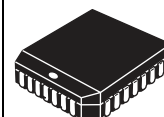

**FN SUFFIX
28-LEAD PLCC PACKAGE
CASE 776-02**

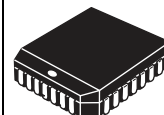

**EI SUFFIX
28-LEAD PLCC PACKAGE
Pb-FREE PACKAGE
CASE 776-02**



**FA SUFFIX
32-LEAD LQFP PACKAGE
CASE 873A-03**



**AC SUFFIX
32-LEAD LQFP PACKAGE
Pb-FREE PACKAGE
CASE 873A-03**

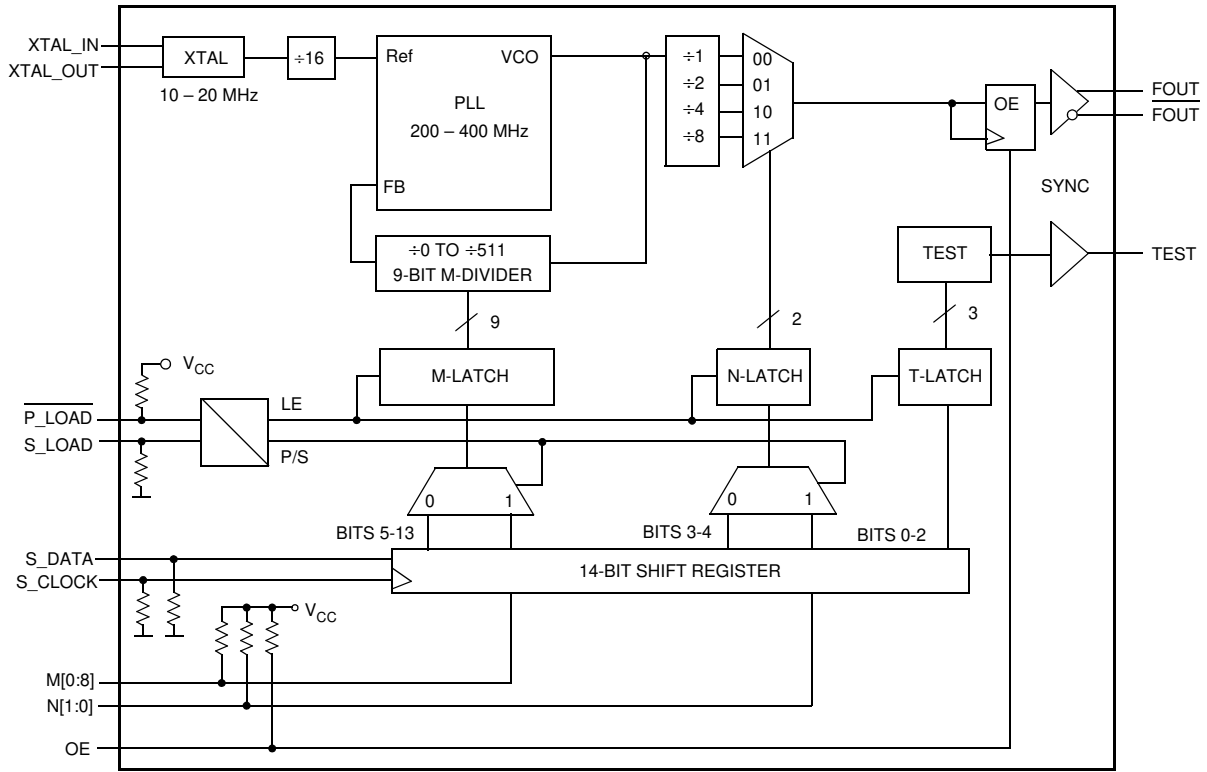

Figure 1. MPC92429 Logic Diagram

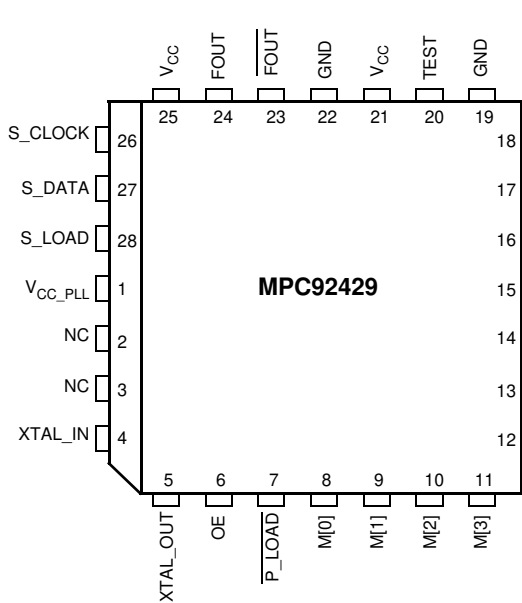

Figure 2. MPC92429 28-Lead PLCC Pinout (Top View)

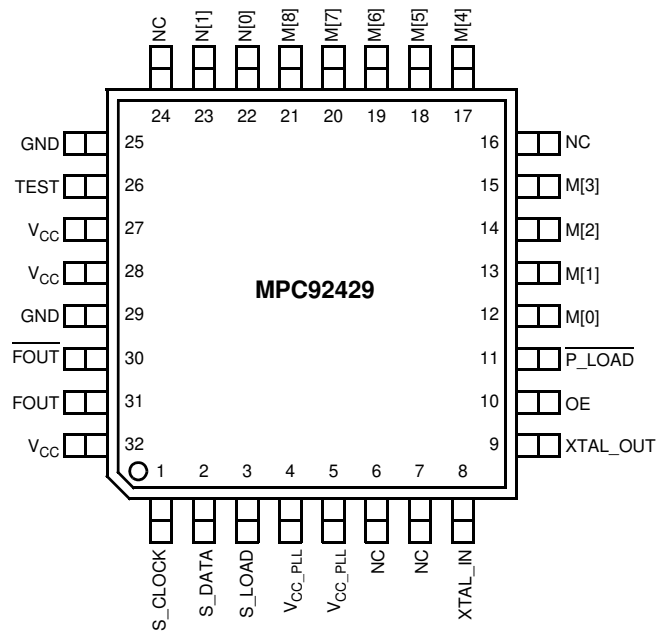

Figure 3. MPC92429 32-Lead Package Pinout (Top View)

Table 1. Pin Configurations

Pin	I/O	Default	Type	Function
XTAL_IN, XTAL_OUT			Analog	Crystal oscillator interface.
F _{OUT} , $\overline{\text{F}}_{\text{OUT}}$	Output		LVPECL	Differential clock output.
TEST	Output		LVC MOS	Test and device diagnosis output.
S_LOAD	Input	0	LVC MOS	Serial configuration control input. This input controls the loading of the configuration latches with the contents of the shift register. The latches will be transparent when this signal is high, thus the data must be stable on the high-to-low transition.
$\overline{\text{P}}_{\text{LOAD}}$	Input	1	LVC MOS	Parallel configuration control input. This input controls the loading of the configuration latches with the content of the parallel inputs (M and N). The latches will be transparent when this signal is low, thus the parallel data must be stable on the low-to-high transition of $\overline{\text{P}}_{\text{LOAD}}$. $\overline{\text{P}}_{\text{LOAD}}$ is state sensitive.
S_DATA	Input	0	LVC MOS	Serial configuration data input.
S_CLOCK	Input	0	LVC MOS	Serial configuration clock input.
M[0:8]	Input	1	LVC MOS	Parallel configuration for PLL feedback divider (M). M is sampled on the low-to-high transition of $\overline{\text{P}}_{\text{LOAD}}$.
N[1:0]	Input	1	LVC MOS	Parallel configuration for Post-PLL divider (N). N is sampled on the low-to-high transition of $\overline{\text{P}}_{\text{LOAD}}$.
OE	Input	1	LVC MOS	Output enable (active high). The output enable is synchronous to the output clock to eliminate the possibility of runt pulses on the F _{OUT} output. OE = L low stops F _{OUT} in the logic low state (F _{OUT} = L, $\overline{\text{F}}_{\text{OUT}}$ = H).
GND	Supply	Supply	Ground	Negative power supply (GND).
V _{CC}	Supply	Supply	V _{CC}	Positive power supply for I/O and core. All V _{CC} pins must be connected to the positive power supply for correct operation.
V _{CC_PLL}	Supply	Supply	V _{CC}	PLL positive power supply (analog power supply).

Table 2. Output Frequency Range and PLL Post-Divider N

N		Output Division	Output Frequency Range
1	0		
0	0	1	200 – 400 MHz
0	1	2	100 – 200 MHz
1	0	4	50 – 100 MHz
1	1	8	25 – 50 MHz

Table 3. General Specifications

Symbol	Characteristics	Min	Typ	Max	Unit	Condition
V_{TT}	Output Termination Voltage		$V_{CC} - 2$		V	
MM	ESD Protection (Machine Model)	200			V	
HBM	ESD Protection (Human Body Model)	2000			V	
LU	Latch-Up Immunity	200			mA	
C_{IN}	Input Capacitance		4.0		pF	Inputs
θ_{JA}	LQFP 32 Thermal Resistance Junction to Ambient JESD 51-3, single layer test board		83.1	86.0	°C/W	Natural convection
			73.3	75.4	°C/W	100 ft/min
			68.9	70.9	°C/W	200 ft/min
			63.8	65.3	°C/W	400 ft/min
			57.4	59.6	°C/W	800 ft/min
	JESD 51-6, 2S2P multilayer test board		59.0	60.6	°C/W	Natural convection
			54.4	55.7	°C/W	100 ft/min
			52.5	53.8	°C/W	200 ft/min
			50.4	51.5	°C/W	400 ft/min
			47.8	48.8	°C/W	800 ft/min
θ_{JC}	LQFP 32 Thermal Resistance Junction to Case		23.0	26.3	°C/W	MIL-SPEC 883E Method 1012.1

Table 4. Absolute Maximum Ratings⁽¹⁾

Symbol	Characteristics	Min	Max	Unit	Condition
V_{CC}	Supply Voltage	-0.3	3.9	V	
V_{IN}	DC Input Voltage	-0.3	$V_{CC} + 0.3$	V	
V_{OUT}	DC Output Voltage	-0.3	$V_{CC} + 0.3$	V	
I_{IN}	DC Input Current		±20	mA	
I_{OUT}	DC Output Current		±50	mA	
T_S	Storage Temperature	-65	125	°C	

1. Absolute maximum continuous ratings are those maximum values beyond which damage to the device may occur. Exposure to these conditions or conditions beyond those indicated may adversely affect device reliability. Functional operation at absolute-maximum-rated conditions is not implied.

Table 5. DC Characteristics ($V_{CC} = 3.3 \text{ V} \pm 5\%$, $T_A = 0^\circ\text{C}$ to $+70^\circ\text{C}$)

Symbol	Characteristics	Min	Typ	Max	Unit	Condition
LVCMOS Control Inputs ($\overline{P_LOAD}$, S_LOAD , S_DATA , S_CLOCK , M[0:8], N[0:1], OE)						
V_{IH}	Input High Voltage	2.0		$V_{CC} + 0.3$	V	LVCMOS
V_{IL}	Input Low Voltage			0.8	V	LVCMOS
I_{IN}	Input Current ⁽¹⁾			±200	μA	$V_{IN} = V_{CC}$ or GND
Differential Clock Output F_{OUT} ⁽²⁾						
V_{OH}	Output High Voltage ⁽³⁾	$V_{CC} - 1.02$		$V_{CC} - 0.74$	V	LVPECL
V_{OL}	Output Low Voltage ⁽³⁾	$V_{CC} - 1.95$		$V_{CC} - 1.60$	V	LVPECL
Test and Diagnosis Output TEST						
V_{OH}	Output High Voltage ⁽³⁾	2.0			V	$I_{OH} = -0.8 \text{ mA}$
V_{OL}	Output Low Voltage ⁽³⁾			0.55	V	$I_{OH} = 0.8 \text{ mA}$
Supply Current						
I_{CC_PLL}	Maximum PLL Supply Current			20	mA	V_{CC_PLL} Pins
I_{CC}	Maximum Supply Current			100	mA	All V_{CC} Pins

1. Inputs have pull-down resistors affecting the input current.

2. Outputs terminated 50 Ω to $V_{TT} = V_{CC} - 2 V$.
3. The MPC92429 TEST output levels are compatible to the MC12429 output levels.

Table 6. AC Characteristics ($V_{CC} = 3.3 V \pm 5\%$, $T_A = 0^\circ C$ to $+70^\circ C$)(¹)

Symbol	Characteristics	Min	Typ	Max	Unit	Condition
f_{XTAL}	Crystal Interface Frequency Range	10		20	MHz	
f_{VCO}	VCO Frequency Range(²)	200		400	MHz	
f_{MAX}	Output Frequency	N = 00 ($\div 1$)	200		400	MHz
		N = 01 ($\div 2$)	100		200	MHz
		N = 10 ($\div 4$)	50		100	MHz
		N = 11 ($\div 8$)	25		50	MHz
DC	Output Duty Cycle	45	50	55	%	
t_r, t_f	Output Rise/Fall Time	0.05		0.3	ns	20% to 80%
f_{S_CLOCK}	Serial Interface Programming Clock Frequency(³)	0		10	MHz	
$t_{P,MIN}$	Minimum Pulse Width (S_LOAD, P_LOAD)	50			ns	
t_S	Setup Time	S_DATA to S_CLOCK	20			ns
		S_CLOCK to S_LOAD	20			ns
		M, N to P_LOAD	20			ns
t_S	Hold Time	S_DATA to S_CLOCK	20			ns
		M, N to P_LOAD	20			ns
$t_{JIT(CC)}$	Cycle-to-Cycle Jitter	N = 00 ($\div 1$)			90	ps
		N = 01 ($\div 2$)			130	ps
		N = 10 ($\div 4$)			160	ps
		N = 11 ($\div 8$)			190	ps
$t_{JIT(PER)}$	Period Jitter	N = 00 ($\div 1$)			70	ps
		N = 01 ($\div 2$)			120	ps
		N = 10 ($\div 4$)			140	ps
		N = 11 ($\div 8$)			170	ps
t_{LOCK}	Maximum PLL Lock Time			10	ms	

1. AC characteristics apply for parallel output termination of 50 Ω to V_{TT} .
2. The input frequency f_{XTAL} and the PLL feedback divider M must match the VCO frequency range: $f_{VCO} = f_{XTAL} \times M$.
3. The frequency of S_CLOCK is limited to 10 MHz in serial programming mode. S_CLOCK can be switched at higher frequencies when used as test clock in test mode 6. See [APPLICATIONS INFORMATION](#) for more details.

PROGRAMMING INTERFACE

Programming the MPC92429

Programming the MPC92429 amounts to properly configuring the internal PLL dividers to produce the desired synthesized frequency at the output. The output frequency can be represented by this formula:

$$F_{OUT} = (f_{XTAL} \div 16) \times (M) \div (N) \tag{1}$$

where f_{XTAL} is the crystal frequency, M is the PLL feedback-divider and N is the PLL post-divider. The input frequency and the selection of the feedback divider M is limited by the VCO-frequency range. f_{XTAL} and M must be configured to

match the VCO frequency range of 200 to 400 MHz in order to achieve stable PLL operation:

$$M_{MIN} = f_{VCO,MIN} \div f_{XTAL} \text{ and} \tag{2}$$

$$M_{MAX} = f_{VCO,MAX} \div f_{XTAL} \tag{3}$$

For instance, the use of a 16 MHz input frequency requires the configuration of the PLL feedback divider between M = 200 and M = 400. Table 7 shows the usable VCO frequency and M divider range for other example input frequencies. Assuming that a 16 MHz input frequency is used, equation 1 reduces to:

$$F_{OUT} = M \div N \tag{4}$$

Table 7. MPC92429 Frequency Operating Range

M	M[8:0]	VCO frequency for an crystal interface frequency of						Output frequency for $f_{XTAL} = 16 \text{ MHz}$ and for $N =$			
		10	12	14	16	18	20	1	2	4	8
160	010100000						200				
170	010101010						212.5				
180	010110100					202.5	225				
190	010111110					213.75	237.5				
200	011001000				200	225	250	200	100	50	25
210	011010010				210	236.25	262.5	210	105	52.5	26.25
220	011011100				220	247.5	275	220	110	55	27.5
230	011100110			201.25	230	258.75	287.5	230	115	57.5	28.75
240	011110000			210	240	270	300	240	120	60	30
250	011111010			218.75	250	281.25	312.5	250	125	62.5	31.25
260	100000100			227.5	260	292.5	325	260	130	65	32.5
270	100001110		202.5	236.25	270	303.75	337.5	270	135	67.5	33.75
280	100011000		210	245	280	315	350	280	140	70	35
290	100100010		217.5	253.75	290	326.25	362.5	290	145	72.5	36.25
300	100101100		225	262.5	300	337.5	375	300	150	75	37.5
310	100110110		232.5	271.25	310	348.75	387.5	310	155	77.5	38.75
320	101000000	200	240	280	320	360	400	320	160	80	40
330	101001010	206.25	247.5	288.75	330	371.25		330	165	82.5	41.25
340	101010100	212.5	255	297.5	340	382.5		340	170	85	42.5
350	101011110	218.75	262.5	306.25	350	393.75		350	175	87.5	43.75
360	101101000	225	270	315	360			360	180	90	45
370	101110010	231.25	277.5	323.75	370			370	185	92.5	46.25
380	101111100	237.5	285	332.5	380			380	190	95	47.5
390	110000110	243.75	292.5	341.25	390			390	195	97.5	48.75
400	110010000	250	300	350	400			400	200	100	50
410	110011010	256.25	307.5	358.75							
420	110100100	262.5	315	367.5							
430	110101110	268.75	322.5	376.25							
440	110111000	275	330	385							
450	111000010	281.25	337.5	393.75							
510	111111110	318.75	382.5								

Substituting N for the four available values for N (1, 2, 4, 8) yields:

Table 8. Output Frequency Range for $f_{XTAL} = 16$ MHz

N			F _{OUT}	F _{OUT} Range	F _{OUT} Step
1	0	Value			
0	0	1	M	200 – 400 MHz	1 MHz
0	1	2	M÷2	100 – 200 MHz	500 kHz
1	0	4	M÷4	50 – 100 MHz	250 kHz
1	1	8	M÷8	25 – 50 MHz	125 kHz

Example Frequency Calculation for an 16 MHz Input Frequency

If an output frequency of 131 MHz was desired the following steps would be taken to identify the appropriate M and N values. According to Table 8, 131 MHz falls in the frequency set by an value of 2 so N[1:0] = 01. For N = 2 the output frequency is $F_{OUT} = M \div 2$ and $M = F_{OUT} \times 2$. Therefore $M = 2 \times 131 = 262$, so M[8:0] = 100000110. Following this procedure a user can generate any whole frequency between 25 MHz and 400 MHz. Note that for N > 2 fractional values of can be realized. The size of the programmable frequency steps (and thus the indicator of the fractional output frequencies achievable) will be equal to:

$$f_{STEP} = f_{XTAL} \div 16 \div N \tag{5}$$

APPLICATIONS INFORMATION

Using the Parallel and Serial Interface

The M and N counters can be loaded either through a parallel or serial interface. The parallel interface is controlled via the P_LOAD signal such that a LOW-to-HIGH transition will latch the information present on the M[8:0] and N[1:0] inputs into the M and N counters. When the P_LOAD signal is LOW the input latches will be transparent and any changes on the M[8:0] and N[1:0] inputs will affect the FOUT output pair. To use the serial port the S_CLOCK signal samples the information on the S_DATA line and loads it into a 14 bit shift register. Note that the P_LOAD signal must be HIGH for the serial load operation to function. The Test register is loaded with the first three bits, the N register with the next two and the M register with the final eight bits of the data stream on the S_DATA input. For each register the most significant bit is loaded first (T2, N1 and M8). A pulse on the S_LOAD pin after the shift register is fully loaded will transfer the divide values into the counters. The HIGH-to-LOW transition on the S_LOAD input will latch the new divide values into the counters. Figure 4 illustrates the timing diagram for both a parallel and a serial load of the MPC92429 synthesizer. M[8:0] and N[1:0] are normally specified once at power-up through the parallel interface, and then possibly again through the serial interface. This approach allows the application to come up at one frequency and then change or fine-tune the clock as the ability to control the serial interface becomes available.

Using the Test and Diagnosis Output TEST

The TEST output provides visibility for one of the several internal nodes as determined by the T[2:0] bits in the serial configuration stream. It is not configurable through the parallel interface. Although it is possible to select the node that represents F_{OUT}, the CMOS output is not able to toggle fast enough for higher output frequencies and should only be used for test and diagnosis. The T2, T1 and T0 control bits are preset to '000' when P_LOAD is LOW so that the PECL FOUT outputs are as jitter-free as possible. Any active signal on the TEST output pin will have detrimental affects on the jitter of the PECL output pair. In normal operations, jitter specifications are only guaranteed if the TEST output is static. The serial configuration port can be used to select one of the alternate functions for this pin. Most of the signals

available on the TEST output pin are useful only for performance verification of the MPC92429 itself. However the PLL bypass mode may be of interest at the board level for functional debug. When T[2:0] is set to 110 the MPC92429 is placed in PLL bypass mode. In this mode the S_CLOCK input is fed directly into the M and N dividers. The N divider drives the F_{OUT} differential pair and the M counter drives the TEST output pin. In this mode the S_CLOCK input could be used for low speed board level functional test or debug. Bypassing the PLL and driving F_{OUT} directly gives the user more control on the test clocks sent through the clock tree. Figure 6 shows the functional setup of the PLL bypass mode. Because the S_CLOCK is a CMOS level the input frequency is limited to 200 MHz. This means the fastest the F_{OUT} pin can be toggled via the S_CLOCK is 100 MHz as the divide ratio of the Post-PLL divider is 2 (if N = 1). Note that the M counter output on the TEST output will not be a 50% duty cycle.

Table 9. Test and Debug Configuration for TEST

T[2:0]			TEST Output
T2	T1	T0	
0	0	0	14-bit shift register out ⁽¹⁾
0	0	1	Logic 1
0	1	0	$f_{XTAL} \div 16$
0	1	1	M-Counter out
1	0	0	FOUT
1	0	1	Logic 0
1	1	0	M-Counter out in PLL-bypass mode
1	1	1	FOUT ÷ 4

1. Clocked out at the rate of S_CLOCK.

Table 10. Debug Configuration for PLL Bypass⁽¹⁾

Output	Configuration
F _{OUT}	S_CLOCK ÷ N
TEST	M-Counter out ⁽²⁾

1. T[2:0] = 110. AC specifications do not apply in PLL bypass mode.

2. Clocked out at the rate of $S_CLOCK \div (4 \cdot N)$

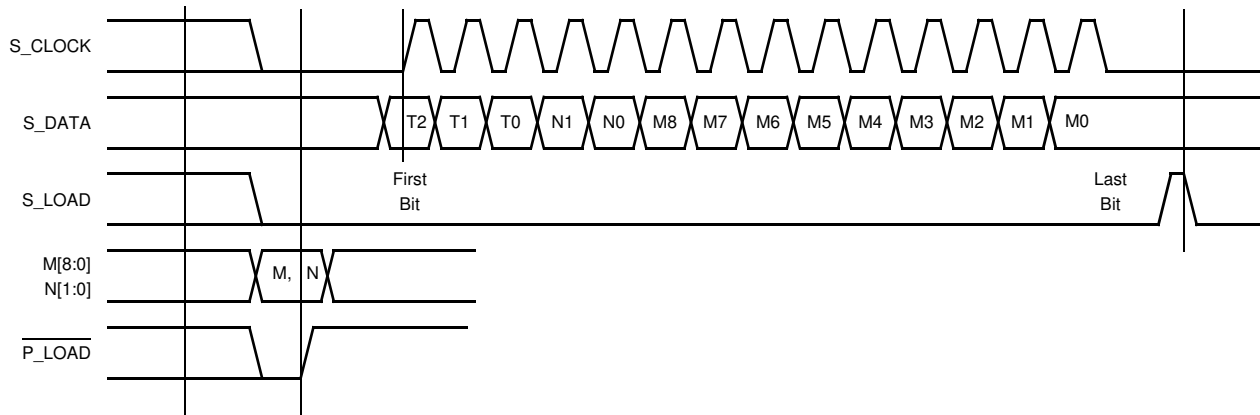

Figure 4. Serial Interface Timing Diagram

Power Supply Filtering

The MPC92429 is a mixed analog/digital product. Its analog circuitry is naturally susceptible to random noise, especially if this noise is seen on the power supply pins. Random noise on the V_{CC_PLL} pin impacts the device characteristics. The MPC92429 provides separate power supplies for the digital circuitry (V_{CC}) and the internal PLL (V_{CC_PLL}) of the device. The purpose of this design technique is to try and isolate the high switching noise digital outputs from the relatively sensitive internal analog phase-locked loop. In a controlled environment such as an evaluation board, this level of isolation is sufficient. However, in a digital system environment where it is more difficult to minimize noise on the power supplies a second level of isolation may be required. The simplest form of isolation is a power supply filter on the V_{CC_PLL} pin for the MPC92429. Figure 5 illustrates a typical power supply filter scheme. The MPC92429 is most susceptible to noise with spectral content in the 1 kHz to 1 MHz range. Therefore, the filter should be designed to target this range. The key parameter that needs to be met in the final filter design is the DC voltage drop that will be seen between the V_{CC} supply and the MPC92429 pin of the MPC92429. From the data sheet, the V_{CC_PLL} current (the current sourced through the V_{CC_PLL} pin) is maximum 20 mA, assuming that a minimum of 2.835 V must be maintained on the V_{CC_PLL} pin. The resistor shown in Figure 5 must have a resistance of 10-15 Ω to meet the voltage drop criteria. The RC filter pictured will provide a broadband filter with approximately 100:1 attenuation for noise whose spectral content is above 20 kHz. As the noise frequency crosses the series resonant point of an individual capacitor its overall impedance begins to look inductive and thus increases with increasing frequency. The parallel capacitor combination shown ensures that a low impedance path to ground exists for frequencies well above the bandwidth of the PLL. Generally, the resistor/capacitor filter will be cheaper, easier to implement and provide an adequate level of supply filtering. A higher level of attenuation can be achieved by replacing the resistor with an appropriate valued inductor. A 1000 μ H choke will show a significant impedance at 10 kHz frequencies and above. Because of the current

draw and the voltage that must be maintained on the V_{CC_PLL} pin, a low DC resistance inductor is required (less than 15 Ω).

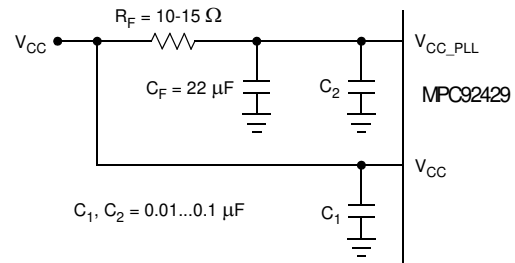

Figure 5. V_{CC_PLL} Power Supply Filter

Layout Recommendations

The MPC92429 provides sub-nanosecond output edge rates and thus a good power supply bypassing scheme is a must. Figure 6 shows a representative board layout for the MPC92429. There exists many different potential board layouts and the one pictured is but one. The important aspect of the layout in Figure 6 is the low impedance connections between V_{CC} and GND for the bypass capacitors. Combining good quality general purpose chip capacitors with good PCB layout techniques will produce effective capacitor resonances at frequencies adequate to supply the instantaneous switching current for the MPC92429 outputs. It is imperative that low inductance chip capacitors are used; it is equally important that the board layout does not introduce back all of the inductance saved by using the leadless capacitors. Thin interconnect traces between the capacitor and the power plane should be avoided and multiple large vias should be used to tie the capacitors to the buried power planes. Fat interconnect and large vias will help to minimize layout induced inductance and thus maximize the series resonant point of the bypass capacitors. Note the dotted lines circling the crystal oscillator connection to the device. The oscillator is a series resonant circuit and the voltage amplitude across the crystal is relatively small. It is imperative that no actively switching signals cross under the crystal as crosstalk energy coupled to these lines could significantly impact the jitter of the device. Special attention should be paid to the layout of

the crystal to ensure a stable, jitter free interface between the crystal and the on-board oscillator. Although the MPC92429 has several design features to minimize the susceptibility to power supply noise (isolated power and grounds and fully differential PLL), there still may be applications in which overall performance is being degraded due to system power supply noise. The power supply filter and bypass schemes discussed in this section should be adequate to eliminate power supply noise related problems in most designs.

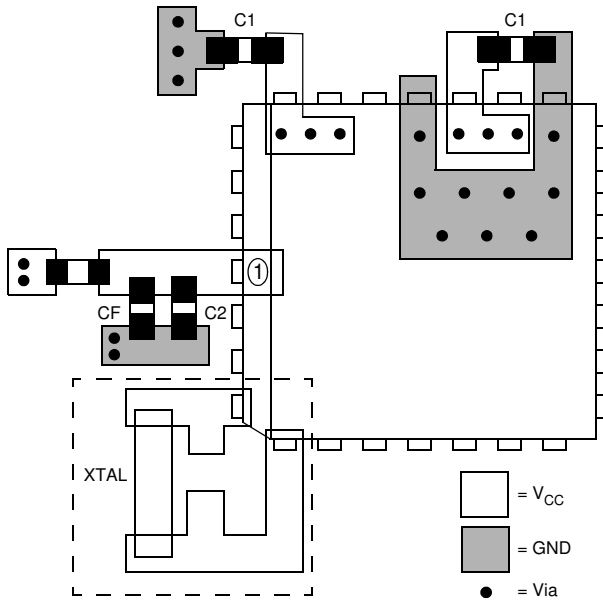

Figure 6. PCB Board Layout Recommendation for the PLCC28 Package

The On-Chip Crystal Oscillator

The MPC92429 features an integrated on-chip crystal oscillator to minimize system implementation cost. The integrated oscillator is a Pierce-type that uses the crystal in its parallel resonance mode. It is recommended to use a 10 to 20 MHz crystal with a load specification of $C_L = 10$ pF. Crystals with a load specification of $C_L = 20$ pF may be used at the expense of an slightly higher frequency than specified for the crystal. Externally connected capacitors on both the XTAL_IN and XTAL_OUT pins are not required but can be used to fine-tune the crystal frequency as desired.

The crystal, the trace and optional capacitors should be placed on the board as close as possible to the MPC92429 XTAL_IN and XTAL_OUT pins to reduce crosstalk of active signals into the oscillator. Short and wide traces further reduce parasitic inductance and resistance. It is further recommended to guard the crystal circuit by placing a ground ring around the traces and oscillator components. See [Table 11](#) for recommended crystal specifications.

Table 11. Recommended Crystal Specifications

Parameter	Value
Crystal Cut	Fundamental AT Cut
Resonance Mode	Parallel
Crystal Frequency	10–20 MHz
Shunt Capacitance C_0	5–7 pF
Load Capacitance C_L	10 pF
Equivalent Series Resistance ESR	20–60 Ω

As an alternative to parallel resonance mode crystals, the oscillator also works with crystals specified in the series resonance mode. With series resonance crystals, the oscillator frequency and the synthesized output frequency of the MPC92429 will be a approximately 350-400 ppm higher than using crystals specified for parallel frequency mode.

This is applicable to applications using the MPC92429 in sockets designed for the pin and function compatible MC12429 synthesizer, which has an oscillator using the crystal in its series resonance mode. [Table 12](#) shows the recommended specifications for series resonance mode crystals.

Table 12. Alternative Crystal Specifications

Parameter	Value
Crystal Cut	Fundamental AT Cut
Resonance Mode	Series
Crystal Frequency	10–20 MHz
Shunt Capacitance C_0	5–7 pF
Equivalent Series Resistance ESR	50–80 Ω

PACKAGE DIMENSIONS

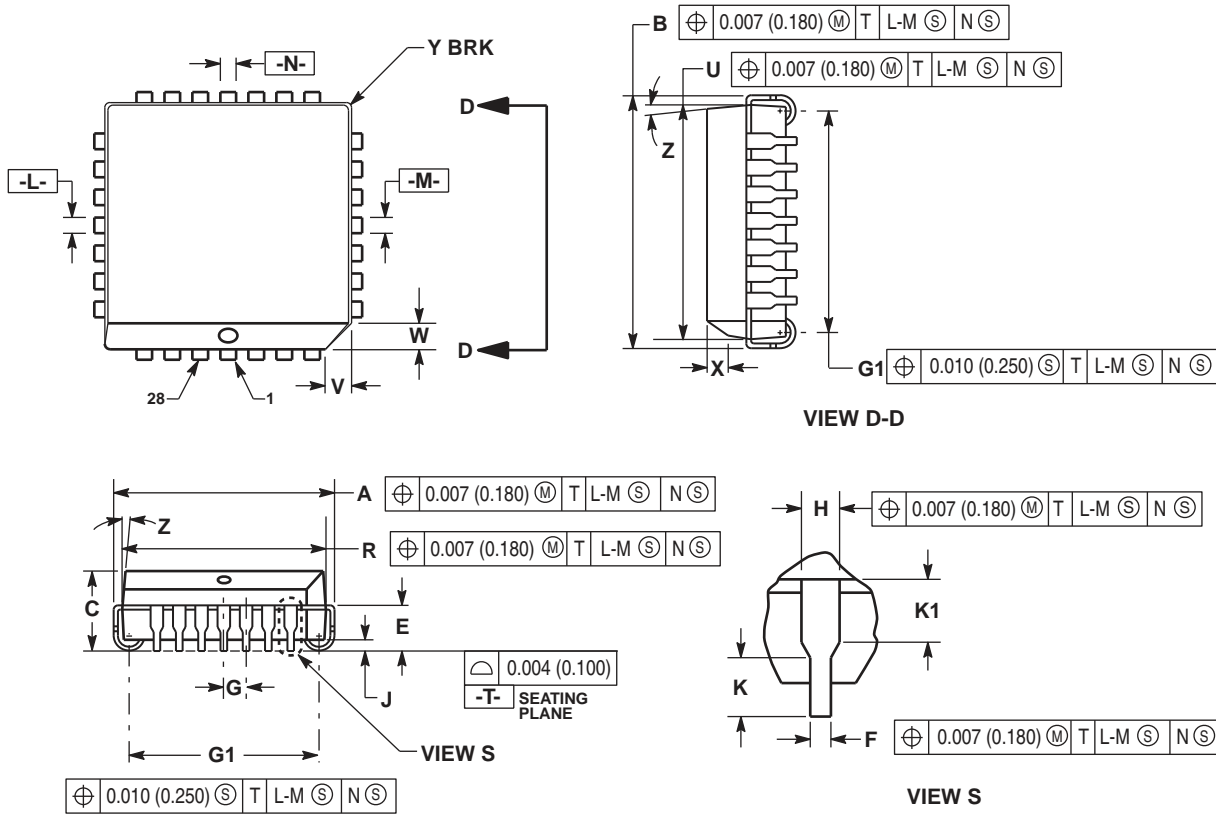

NOTES:

- DATUMS -L-, -M-, AND -N- DETERMINED WHERE TOP OF LEAD SHOULDER EXISTS PLASTIC BODY AT MOLD PARTING LINE.
- DIMENSION G1, TRUE POSITION TO BE MEASURED AT DATUM -T-, SEATING PLANE.
- DIMENSIONS R AND U DO NOT INCLUDE MOLD FLASH. ALLOWABLE MOLD FLASH IS 0.010 (0.250) PER SIDE.
- DIMENSIONING AND TOLERANCING PER ANSI Y14.5M, 1982.
- CONTROLLING DIMENSION: INCH.
- THE PACKAGE TOP MAY BE SMALLER THAN THE PACKAGE BOTTOM BY UP TO 0.012 (0.300). DIMENSIONS R AND U ARE DETERMINED AT THE OUTERMOST EXTREMES OF THE PLASTIC BODY EXCLUSIVE OF MOLD FLASH, TIE BAR BURRS, GATE BURRS AND INTERLEAD FLASH, BUT INCLUDING ANY MISMATCH BETWEEN THE TOP AND BOTTOM OF THE PLASTIC BODY.
- DIMENSION H DOES NOT INCLUDE DAMBAR PROTRUSION OR INTRUSION. THE DAMBAR PROTRUSION(S) SHALL NOT CAUSE THE H DIMENSION TO BE GREATER THAN 0.037 (0.940). THE DAMBAR INTRUSION(S) SHALL NOT CAUSE THE H DIMENSION TO BE SMALLER THAN 0.025 (0.635).

DIM	INCHES		MILLIMETERS	
	MIN	MAX	MIN	MAX
A	0.485	0.495	12.32	12.57
B	0.485	0.495	12.32	12.57
C	0.165	0.180	4.20	4.57
E	0.090	0.110	2.29	2.79
F	0.013	0.019	0.33	0.48
G	0.050 BSC		1.27 BSC	
H	0.026	0.032	0.66	0.81
J	0.020	---	0.51	---
K	0.025	---	0.64	---
R	0.450	0.456	11.43	11.58
U	0.450	0.456	11.43	11.58
V	0.042	0.048	1.07	1.21
W	0.042	0.048	1.07	1.21
X	0.042	0.056	1.07	1.42
Y	---	0.020	---	0.50
Z	2"	10"	2"	10"
G1	0.410	0.430	10.42	10.92
K1	0.040	---	1.02	---

CASE 776-02
ISSUE D
28-LEAD PLCC PACKAGE

PACKAGE DIMENSIONS

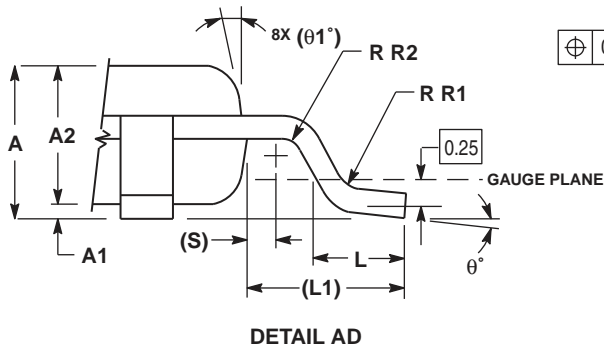
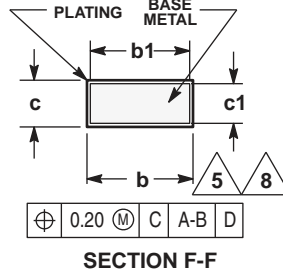
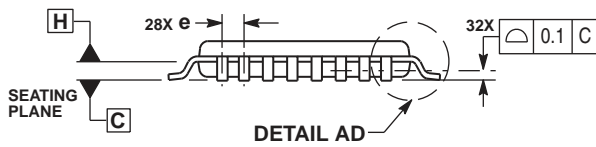
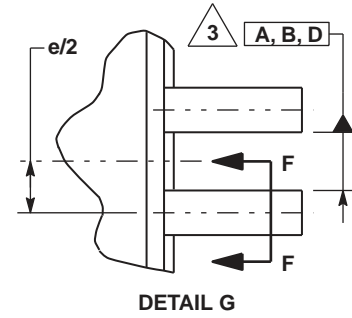
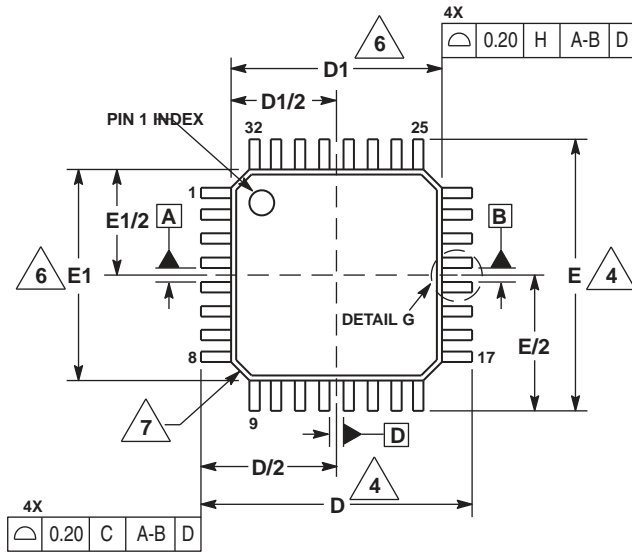

- NOTES:
1. DIMENSIONS ARE IN MILLIMETERS.
 2. INTERPRET DIMENSIONS AND TOLERANCES PER ASME Y14.5M, 1994.
 3. DATUMS A, B, AND D TO BE DETERMINED AT DATUM PLANE H.
 4. DIMENSIONS D AND E TO BE DETERMINED AT SEATING PLANE C.
 5. DIMENSION b DOES NOT INCLUDE DAMBAR PROTRUSION. ALLOWABLE DAMBAR PROTRUSION SHALL NOT CAUSE THE LEAD WIDTH TO EXCEED THE MAXIMUM b DIMENSION BY MORE THAN 0.08-mm. DAMBAR CANNOT BE LOCATED ON THE LOWER RADIUS OR THE FOOT. MINIMUM SPACE BETWEEN PROTRUSION AND ADJACENT LEAD OR PROTRUSION: 0.07-mm.
 6. DIMENSIONS D1 AND E1 DO NOT INCLUDE MOLD PROTRUSION. ALLOWABLE PROTRUSION IS 0.25-mm PER SIDE. D1 AND E1 ARE MAXIMUM PLASTIC BODY SIZE DIMENSIONS INCLUDING MOLD MISMATCH.
 7. EXACT SHAPE OF EACH CORNER IS OPTIONAL.
 8. THESE DIMENSIONS APPLY TO THE FLAT SECTION OF THE LEAD BETWEEN 0.1-mm AND 0.25-mm FROM THE LEAD TIP.

DIM	MILLIMETERS	
	MIN	MAX
A	1.40	1.60
A1	0.05	0.15
A2	1.35	1.45
b	0.30	0.45
b1	0.30	0.40
c	0.09	0.20
c1	0.09	0.16
D	9.00 BSC	
D1	7.00 BSC	
e	0.80 BSC	
E	9.00 BSC	
E1	7.00 BSC	
L	0.50	0.70
L1	1.00 REF	
q	0°	7°
q1	12 REF	
R1	0.08	0.20
R2	0.08	---
S	0.20 REF	

CASE 873A-03
ISSUE B
32-LEAD LQFP PACKAGE

Revision History Sheet

Rev	Table	Page	Description of Change	Date
3		1	Product Discontinuance Notice - Last Time Buy Expires on (12/3/13) Use replacement part: ICS84329B	12/14/12

IMPORTANT NOTICE AND DISCLAIMER

RENESAS ELECTRONICS CORPORATION AND ITS SUBSIDIARIES (“RENESAS”) PROVIDES TECHNICAL SPECIFICATIONS AND RELIABILITY DATA (INCLUDING DATASHEETS), DESIGN RESOURCES (INCLUDING REFERENCE DESIGNS), APPLICATION OR OTHER DESIGN ADVICE, WEB TOOLS, SAFETY INFORMATION, AND OTHER RESOURCES “AS IS” AND WITH ALL FAULTS, AND DISCLAIMS ALL WARRANTIES, EXPRESS OR IMPLIED, INCLUDING, WITHOUT LIMITATION, ANY IMPLIED WARRANTIES OF MERCHANTABILITY, FITNESS FOR A PARTICULAR PURPOSE, OR NON-INFRINGEMENT OF THIRD PARTY INTELLECTUAL PROPERTY RIGHTS.

These resources are intended for developers skilled in the art designing with Renesas products. You are solely responsible for (1) selecting the appropriate products for your application, (2) designing, validating, and testing your application, and (3) ensuring your application meets applicable standards, and any other safety, security, or other requirements. These resources are subject to change without notice. Renesas grants you permission to use these resources only for development of an application that uses Renesas products. Other reproduction or use of these resources is strictly prohibited. No license is granted to any other Renesas intellectual property or to any third party intellectual property. Renesas disclaims responsibility for, and you will fully indemnify Renesas and its representatives against, any claims, damages, costs, losses, or liabilities arising out of your use of these resources. Renesas' products are provided only subject to Renesas' Terms and Conditions of Sale or other applicable terms agreed to in writing. No use of any Renesas resources expands or otherwise alters any applicable warranties or warranty disclaimers for these products.

(Disclaimer Rev.1.0 Mar 2020)

Corporate Headquarters

TOYOSU FORESIA, 3-2-24 Toyosu,
Koto-ku, Tokyo 135-0061, Japan
www.renesas.com

Contact Information

For further information on a product, technology, the most up-to-date version of a document, or your nearest sales office, please visit:
www.renesas.com/contact/

Trademarks

Renesas and the Renesas logo are trademarks of Renesas Electronics Corporation. All trademarks and registered trademarks are the property of their respective owners.