

SN54F257, SN74F257 QUADRUPLE 2-LINE TO 1-LINE DATA SELECTORS/MULTIPLEXERS WITH 3-STATE OUTPUTS

SDFS065A – D2932, MARCH 1987 – REVISED OCTOBER 1993

- 3-State Outputs Interface Directly With System Bus
- Provides Bus Interface From Multiple Sources in High-Performance Systems
- Package Options Include Plastic Small-Outline Packages, Ceramic Chip Carriers, and Standard Plastic and Ceramic 300-mil DIPs

description

The 'F257 is designed to multiplex signals from 4-bit data sources to 4-output data lines in bus-organized systems. The 3-state outputs will not load the data lines when the output enable (\overline{OE}) input is at a high logic level.

The SN54F257 is characterized for operation over the full military temperature range of -55°C to 125°C . The SN74F257 is characterized for operation from 0°C to 70°C .

FUNCTION TABLE

INPUTS				OUTPUT Y
\overline{OE}	$\overline{A/B}$	A	B	
H	X	X	X	Z
L	L	L	X	L
L	L	H	X	H
L	H	X	L	L
L	H	X	H	H

logic symbol†

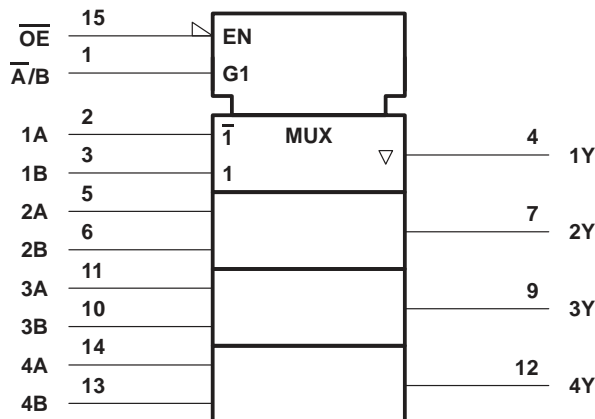

† This symbol is in accordance with ANSI/IEEE Std 91-1984 and IEC Publication 617-12. Pin numbers shown are for the D, J, and N packages.

SN54F257 . . . J PACKAGE
SN74F257 . . . D OR N PACKAGE
(TOP VIEW)

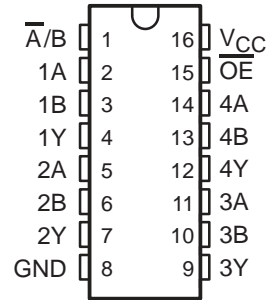

SN54F257 . . . FK PACKAGE
(TOP VIEW)

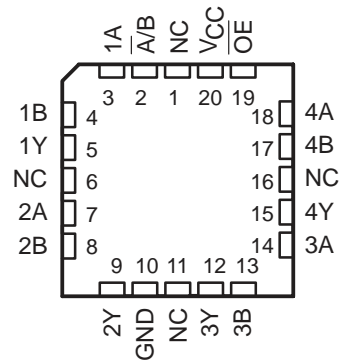

NC – No internal connection

SN54F257, SN74F257 QUADRUPLE 2-LINE TO 1-LINE DATA SELECTORS/MULTIPLEXERS WITH 3-STATE OUTPUTS

SDFS065A – D2932, MARCH 1987 – REVISED OCTOBER 1993

logic diagram (positive logic)

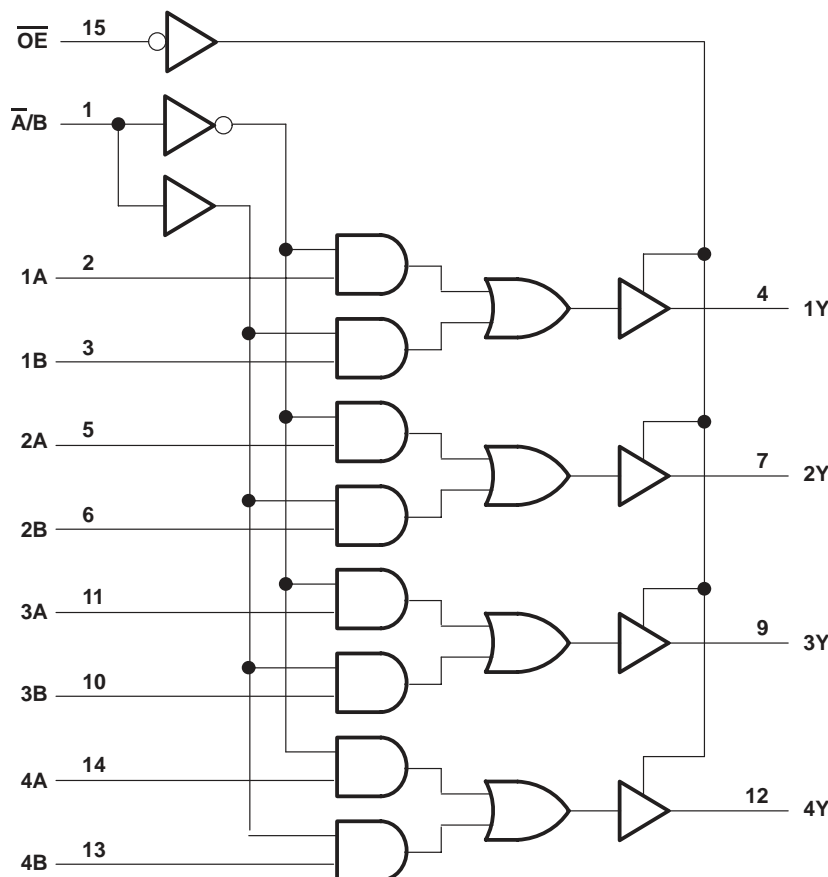

Pin numbers shown are for the D, J, and N packages.

absolute maximum ratings over operating free-air temperature range (unless otherwise noted)[†]

Supply voltage range, V_{CC}	-0.5 V to 7 V
Input voltage range (see Note 1)	-1.2 V to 7 V
Input current range	-30 mA to 5 mA
Voltage range applied to any output in the disabled or power-off state	-0.5 V to 5.5 V
Voltage range applied to any output in the high state	-0.5 V to V_{CC}
Current into any output in the low state: SN54F257	40 mA
SN74F257	48 mA
Operating free-air temperature range: SN54F257	-55°C to 125°C
SN74F257	0°C to 70°C
Storage temperature range	-65°C to 150°C

[†] Stresses beyond those listed under "absolute maximum ratings" may cause permanent damage to the device. These are stress ratings only and functional operation of the device at these or any other conditions beyond those indicated under "recommended operating conditions" is not implied. Exposure to absolute-maximum-rated conditions for extended periods may affect device reliability.

NOTE 1: The input voltage ratings may be exceeded provided the input current ratings are observed.

SN54F257, SN74F257 QUADRUPLE 2-LINE TO 1-LINE DATA SELECTORS/MULTIPLEXERS WITH 3-STATE OUTPUTS

SDFS065A – D2932, MARCH 1987 – REVISED OCTOBER 1993

recommended operating conditions

		SN54F257			SN74F257			UNIT
		MIN	NOM	MAX	MIN	NOM	MAX	
V_{CC}	Supply voltage	4.5	5	5.5	4.5	5	5.5	V
V_{IH}	High-level input voltage	2			2			V
V_{IL}	Low-level input voltage			0.8			0.8	V
I_{IK}	Input clamp current			-18			-18	mA
I_{OH}	High-level output current			-3			-3	mA
I_{OL}	Low-level output current			20			24	mA
T_A	Operating free-air temperature	-55		125	0		70	°C

electrical characteristics over recommended operating free-air temperature range (unless otherwise noted)

PARAMETER	TEST CONDITIONS	SN54F257			SN74F257			UNIT
		MIN	TYP†	MAX	MIN	TYP†	MAX	
V_{IK}	$V_{CC} = 4.5\text{ V}$, $I_I = -18\text{ mA}$			-1.2			-1.2	V
V_{OH}	$V_{CC} = 4.5\text{ V}$	$I_{OH} = -1\text{ mA}$		2.5	3.4	2.5	3.4	V
		$I_{OH} = -3\text{ mA}$		2.4	3.3	2.4	3.3	
V_{OL}	$V_{CC} = 4.5\text{ V}$	$I_{OH} = -1\text{ mA to } -3\text{ mA}$				2.7		V
		$I_{OL} = 20\text{ mA}$		0.3	0.5			
		$I_{OL} = 24\text{ mA}$				0.35	0.5	
I_{OZH}	$V_{CC} = 5.5\text{ V}$, $V_O = 2.7\text{ V}$			50			50	μA
I_{OZL}	$V_{CC} = 5.5\text{ V}$, $V_O = 0.5\text{ V}$			-50			-50	μA
I_I	$V_{CC} = 5.5\text{ V}$, $V_I = 7\text{ V}$			0.1			0.1	mA
I_{IH}	$V_{CC} = 5.5\text{ V}$, $V_I = 2.7\text{ V}$			20			20	μA
I_{IL}	$V_{CC} = 5.5\text{ V}$, $V_I = 0.5\text{ V}$			-0.6			-0.6	mA
$I_{OS}‡$	$V_{CC} = 5.5\text{ V}$, $V_O = 0$	-60		-150	-60		-150	mA
I_{CCH}	$V_{CC} = 5.5\text{ V}$, See Note 2	Condition A		9	15	9	15	mA
I_{CCL}		Condition B		14.5	22	14.5	22	
I_{CCZ}		Condition C		15	23	15	23	

† All typical values are at $V_{CC} = 5\text{ V}$, $T_A = 25^\circ\text{C}$.

‡ Not more than one output should be shorted at a time, and the duration of the short circuit should not exceed one second.

NOTE 2: I_{CC} is measured with the outputs open under the following conditions:

- A. $\overline{A/B}$ and all B inputs at 4.5 V, other inputs grounded
- B. All B inputs at 4.5 V, other inputs grounded
- C. \overline{OE} and all B data inputs at 4.5 V, other inputs grounded

SN54F257, SN74F257
QUADRUPLE 2-LINE TO 1-LINE DATA SELECTORS/MULTIPLEXERS
WITH 3-STATE OUTPUTS

SDFS065A – D2932, MARCH 1987 – REVISED OCTOBER 1993

switching characteristics (see Note 3)

PARAMETER	FROM (INPUT)	TO (OUTPUT)	V _{CC} = 5 V, C _L = 50 pF, R ₁ = 500 Ω, R ₂ = 500 Ω, T _A = 25°C			V _{CC} = 4.5 V to 5.5 V, C _L = 50 pF, R ₁ = 500 Ω, R ₂ = 500 Ω, T _A = MIN to MAX†				UNIT
			F257			SN54F257		SN74F257		
			MIN	TYP	MAX	MIN	MAX	MIN	MAX	
t _{PLH}	A or B	Any Y	2.2	4.1	6	2.2	8	2.2	7	ns
t _{PHL}			1.2	3.8	5.5	1	8	1.2	6.5	
t _{PLH}	A/B	Any Y	3.7	9.7	13	3.7	15.5	3.7	15	ns
t _{PHL}			2.7	6.1	8.5	2.7	10.5	2.7	9.5	
t _{PZH}	G	Any Y	2.2	5.5	7.5	2.2	9.5	2.2	8.5	ns
t _{PZL}			2.2	5.1	7.5	2.2	10	2.2	8.5	
t _{PHZ}	\bar{G}	Any Y	1.2	3.9	6	1.2	7	1.2	7	ns
t _{PLZ}			1.2	4.1	6	1.2	9.5	1.2	7	

† For conditions shown as MIN or MAX, use the appropriate value specified under recommended operating conditions.

NOTE 3: Load circuits and waveforms are shown in Section 1.

IMPORTANT NOTICE

Texas Instruments and its subsidiaries (TI) reserve the right to make changes to their products or to discontinue any product or service without notice, and advise customers to obtain the latest version of relevant information to verify, before placing orders, that information being relied on is current and complete. All products are sold subject to the terms and conditions of sale supplied at the time of order acknowledgement, including those pertaining to warranty, patent infringement, and limitation of liability.

TI warrants performance of its semiconductor products to the specifications applicable at the time of sale in accordance with TI's standard warranty. Testing and other quality control techniques are utilized to the extent TI deems necessary to support this warranty. Specific testing of all parameters of each device is not necessarily performed, except those mandated by government requirements.

CERTAIN APPLICATIONS USING SEMICONDUCTOR PRODUCTS MAY INVOLVE POTENTIAL RISKS OF DEATH, PERSONAL INJURY, OR SEVERE PROPERTY OR ENVIRONMENTAL DAMAGE ("CRITICAL APPLICATIONS"). TI SEMICONDUCTOR PRODUCTS ARE NOT DESIGNED, AUTHORIZED, OR WARRANTED TO BE SUITABLE FOR USE IN LIFE-SUPPORT DEVICES OR SYSTEMS OR OTHER CRITICAL APPLICATIONS. INCLUSION OF TI PRODUCTS IN SUCH APPLICATIONS IS UNDERSTOOD TO BE FULLY AT THE CUSTOMER'S RISK.

In order to minimize risks associated with the customer's applications, adequate design and operating safeguards must be provided by the customer to minimize inherent or procedural hazards.

TI assumes no liability for applications assistance or customer product design. TI does not warrant or represent that any license, either express or implied, is granted under any patent right, copyright, mask work right, or other intellectual property right of TI covering or relating to any combination, machine, or process in which such semiconductor products or services might be or are used. TI's publication of information regarding any third party's products or services does not constitute TI's approval, warranty or endorsement thereof.

[PRODUCT FOLDER](#) | [PRODUCT INFO:](#) [FEATURES](#) | [DESCRIPTION](#) | [DATASHEETS](#) | [PRICING/AVAILABILITY/PKG](#) | [APPLICATION NOTES](#) | [RELATED DOCUMENTS](#)

[PRODUCT SUPPORT:](#) [TRAINING](#)

SN74F257, Quadruple 2-Line To 1-Line Data Selectors/ Multiplexers With 3-State Outputs
DEVICE STATUS: ACTIVE

PARAMETER NAME	SN74F257
Voltage Nodes (V)	5
Vcc range (V)	4.5 to 5.5
Input Level	TTL
Output Level	TTL
Output Drive (mA)	-3/24
Output	3S
From	2
To	1

FEATURES

[▲Back to Top](#)

- 3-State Outputs Interface Directly With System Bus
- Provides Bus Interface From Multiple Sources in High-Performance Systems
- Package Options Include Plastic Small-Outline Packages, Ceramic Chip Carriers, and Standard Plastic and Ceramic 300-mil DIPs

DESCRIPTION

[▲Back to Top](#)

The 7F257 is designed to multiplex signals from 4-bit data sources to 4-output data lines in bus-organized systems. The 3-state outputs will not load the data lines when the output enable (\overline{OE}) input is at a high logic level.

The SN54F257 is characterized for operation over the full military temperature range of -55°C to 125°C. The SN74F257 is characterized for operation from 0°C to 70°C.

TECHNICAL DOCUMENTS

[▲Back to Top](#)

To view the following documents, [Acrobat Reader 4.0](#) is required.

To download a document to your hard drive, right-click on the link and choose 'Save'.

DATASHEET

[▲Back to Top](#)

Full datasheet in Acrobat PDF: [sn74f257.pdf](#) (74 KB, Rev. A) (Updated: 10/01/1993)

APPLICATION NOTES

[▲Back to Top](#)

View Application Notes for [Digital Logic](#)

- [Bus-Interface Devices With Output-Damping Resistors Or Reduced-Drive Outputs \(Rev. A\)](#) (SCBA012A - Updated: 08/01/1997)
- [Designing With Logic \(Rev. C\)](#) (SDYA009C - Updated: 06/01/1997)
- [Evaluation of Nickel/Palladium/Gold-Finished Surface-Mount Integrated Circuits](#) (SZZA026 - Updated: 06/20/2001)
- [Input and Output Characteristics of Digital Integrated Circuits](#) (SDYA010 - Updated: 10/01/1996)

RELATED DOCUMENTS

[▲Back to Top](#)

View Related Documentation for [Digital Logic](#)

- [Logic Reference Guide](#) (SCYB004, 1032 KB - Updated: 10/23/2001)
- [Logic Selection Guide Second Half 2002 \(Rev. R\)](#) (SDYU001R, 4274 KB - Updated: 07/19/2002)
- [Military Semiconductors Selection Guide 2002 \(Rev. B\)](#) (SGYC003B, 1648 KB - Updated: 04/22/2002)

PRICING/ AVAILABILITY/ PKG

[▲Back to Top](#)

DEVICE INFORMATION							TI INVENTORY STATUS AS OF 3:00 PM GMT, 26 Sep 2002			REPORTED DISTRIBUTOR INVENTORY AS OF 3:00 PM GMT, 26 Sep 2002		
ORDERABLE DEVICE	STATUS	PACKAGE TYPE PINS	TEMP (°C)	PRODUCT CONTENT	BUDGETARY PRICING QTY \$US	STD PACK QTY	IN STOCK	IN PROGRESS QTY DATE	LEAD TIME	DISTRIBUTOR COMPANY REGION	IN STOCK	PURCHASE
SN74F257D	ACTIVE	SOP (D) 16	0 TO 70	View Contents	1KU 0.36	40	7240	> 10k 16 Oct	5 WKS	Avnet AMERICA	627	BUY NOW
										DigiKey AMERICA	68	BUY NOW
SN74F257DR	ACTIVE	SOP (D) 16	0 TO 70	View Contents	1KU 0.36	2500	<u>N/A*</u>	2500 07 Oct	5 WKS			
								7500 14 Oct				
								> 10k 15 Oct				
								2500 21 Oct				
SN74F257N	ACTIVE	PDIP (N) 16	0 TO 70	View Contents	1KU 0.36	25	4425	> 10k 21 Oct	5 WKS			
SN74F257NSR	ACTIVE	SOP (NS) 16		View Contents	1KU 0.38	2000	<u>N/A*</u>	> 10k 21 Oct	5 WKS			

Table Data Updated on: 9/26/2002