

PART NUMBER
10120045-200LF

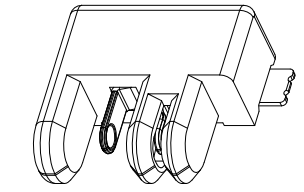

SCALE 3.000

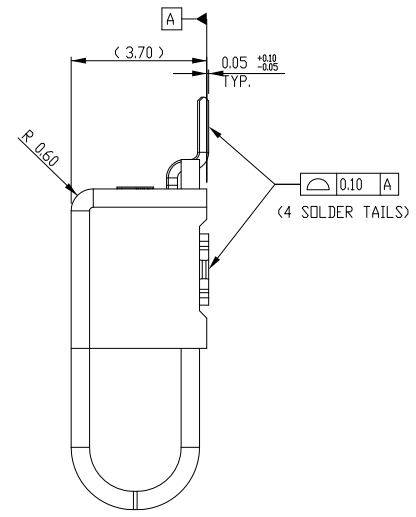
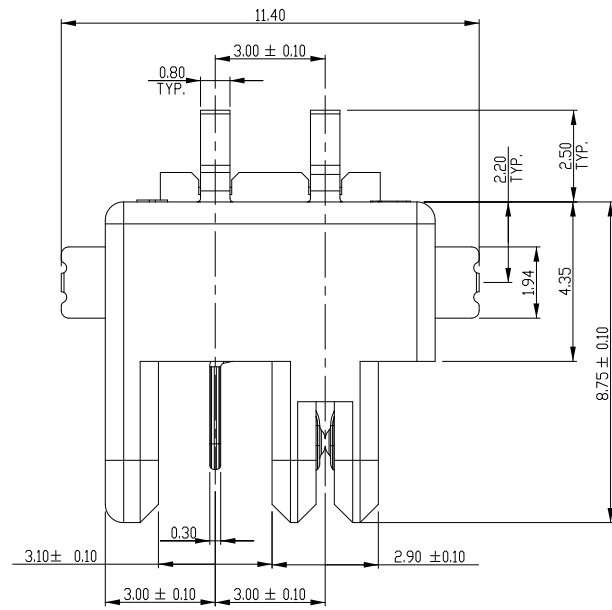
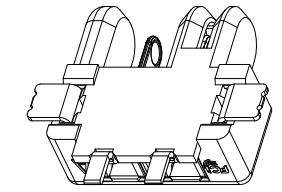

SCALE 3.000

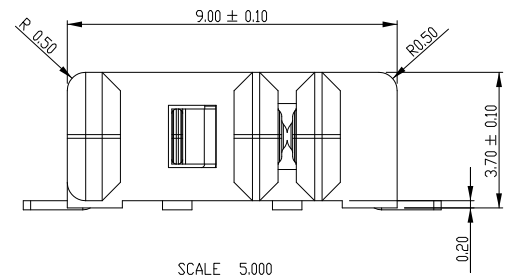

SCALE 5.000

NOTES:
 1. MATERIAL:
 HOUSING: HIGH TEMPERATURE LCP,NATURAL
 UL 94 V-0 FLAME RETARDANT.
 CONTACTS: COPPER ALLOY.
 PLATING SPEC AS BELOW:
 FOR CONTACT AREA:
 * 0.76um GXT™ (30°GXT™);
 FOR SOLDER AREA:
 MATTE PURE TIN 3 um MIN.
 FOR UNDERPLATING:
 1.27 um MIN.THICKNESS NICKEL
 2. PRODUCT SPEC. GS-12-1079.
 3. LEAD FREE NOTES:
 3a.THE HOUSING WILL WITHSTAND EXPOSURE TO 260°C PEAK
 TEMPERATURE FOR 10 SECONDS IN A CONVECTION, INFRA-RED
 OR VAPOR PHASE REFLOW OVEN.
 3b.THIS PRODUCT MEETS EUROPEAN UNION DIRECTIVES AND
 OTHER COUNTRY REGULATIONS AS DESCRIBED IN GS-22-008.
 * GXT™ is an FCI Electronics patented process of palladium-nickel alloy plated with a gold flash.



Copyright FCI.

rev	ecn no	dr	date
A	-	MJA	2013-06-10
-	-	-	-
-	-	-	-
-	-	-	-
-	-	-	-
-	-	-	-

www.fciconnect.com			surface ISO 1302	tolerance std ISO 406 ISO 1101	projection MM	
			TOLERANCES UNLESS OTHERWISE SPECIFIED			
Dr	M JACOB	2013-06-10	ANGULAR	0.x ±x	size A4	Scale 5.000
Eng	M JACOB	2013-06-10	LINEAR	0.xx ±0.2		
Chr	M JACOB	2013-06-10	0° ±2°	0.xxx ±x	ECN	-
Appr	BIJU K PAUL	2013-06-10	Product family-RotaConnect		Spec ref	-
			title ASSEMBLY, 2 POS HDR TYPE ROTATABLE BOARD TO BOARD CONNECTOR			10120045-200C
			catalog no : 10120045-200LF			Rev. A
			CUSTOMER DRAWING		sheet 1 of 3	

PART NUMBER
10120045-200LF

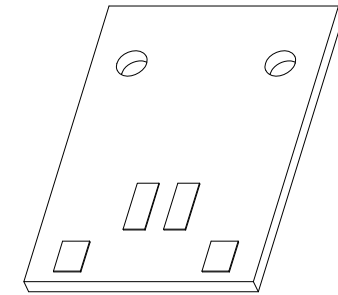

SCALE 2.000

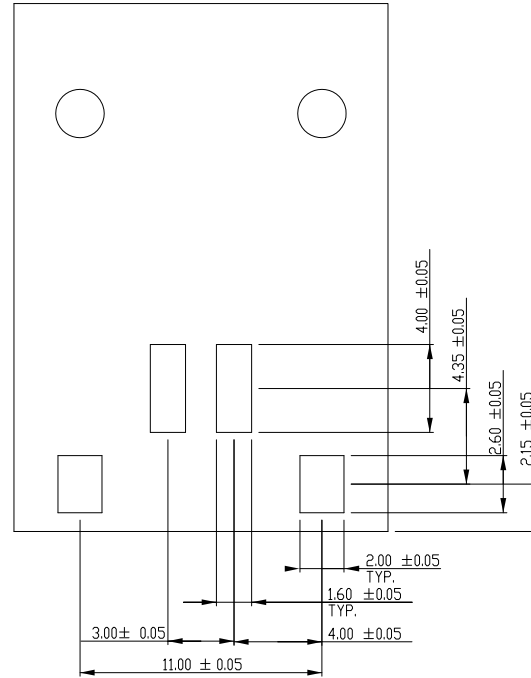

SCALE 3.000



Copyright FCI.

www.fciconnect.com			surface ISO 1302 ✓	tolerance std ISO 406 ISO 1101	projection ⊕	MM ↔																																			
TOLERANCES UNLESS OTHERWISE SPECIFIED			ANGULAR	LINEAR	size A4	Scale 3.000																																			
Dr	M JACOB	2013-06-10	0.X	±X	ECN	-																																			
Eng	M JACOB	2013-06-10	0.XX	±0.2	Spec ref	-																																			
Chr	M JACOB	2013-06-10	0' ±2'	0.XXX ±X																																					
Appr	BIJU K PAUL	2013-06-10	Product family-RotaConnect																																						
<table border="1"> <thead> <tr> <th>rev</th> <th>ecn no</th> <th>dr</th> <th>date</th> </tr> </thead> <tbody> <tr><td>-</td><td>-</td><td>-</td><td>-</td></tr> <tr><td>-</td><td>-</td><td>-</td><td>-</td></tr> <tr><td>-</td><td>-</td><td>-</td><td>-</td></tr> <tr><td>-</td><td>-</td><td>-</td><td>-</td></tr> <tr><td>-</td><td>-</td><td>-</td><td>-</td></tr> <tr><td>-</td><td>-</td><td>-</td><td>-</td></tr> <tr><td>-</td><td>-</td><td>-</td><td>-</td></tr> </tbody> </table>			rev	ecn no	dr	date	-	-	-	-	-	-	-	-	-	-	-	-	-	-	-	-	-	-	-	-	-	-	-	-	-	-	-	-			<table border="1"> <tr> <td>no</td> <td>10120045-200C</td> <td>Rev.</td> <td>A</td> </tr> </table>	no	10120045-200C	Rev.	A
rev	ecn no	dr	date																																						
-	-	-	-																																						
-	-	-	-																																						
-	-	-	-																																						
-	-	-	-																																						
-	-	-	-																																						
-	-	-	-																																						
-	-	-	-																																						
no	10120045-200C	Rev.	A																																						
title ASSEMBLY, 2 POS HDR TYPE ROTATABLE BOARD TO BOARD CONNECTOR			catalog no : 10120045-200LF		CUSTOMER DRAWING sheet 2 of 3																																				

REV F - 2006-04-17

PART NUMBER
10120045-200LF

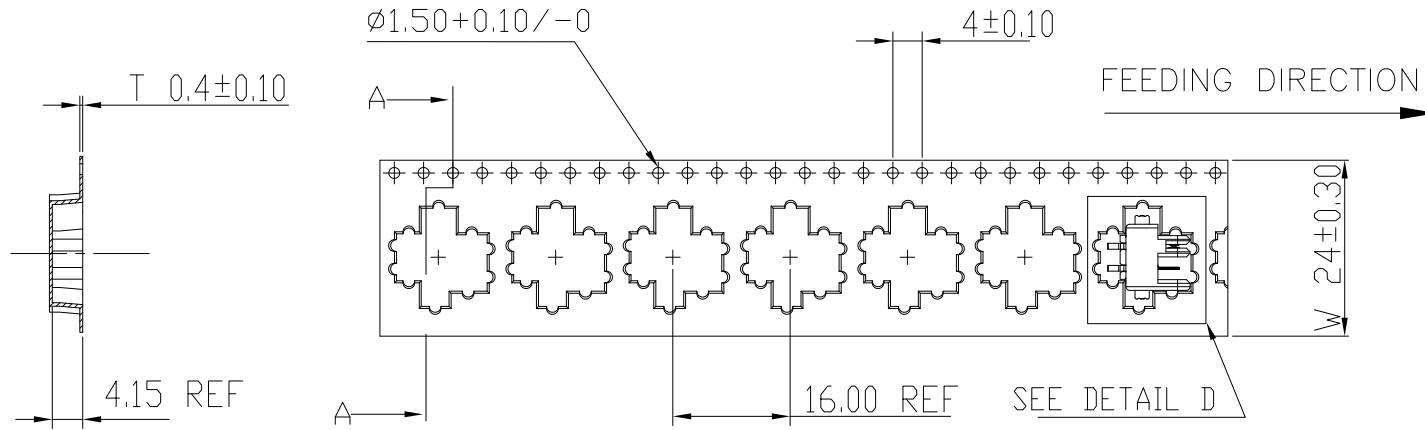

SECTION A-A

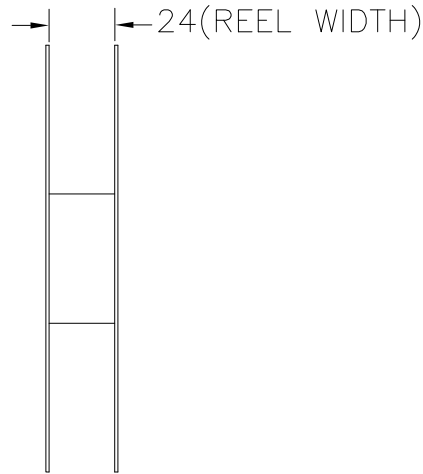
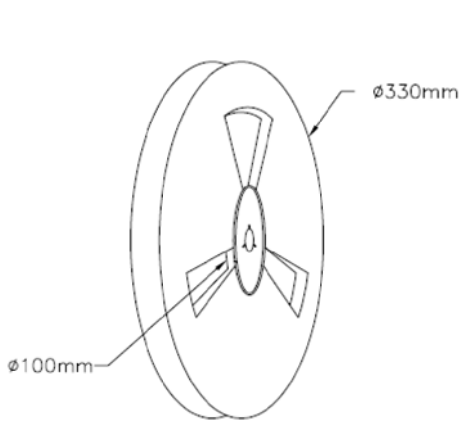

Component inside carrier tape

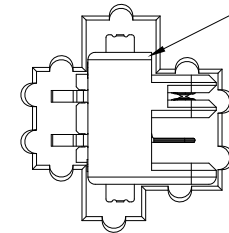

DETAIL D
SCALE 2:1

NOTES :

1. MATERIAL : ANTI-STATIC POLYSTYRENE
2. PACKAGING AS PER EIA-481 STD.
3. QTY PER REEL : 975 NOS

rev	ecn no	dr	date
-	-	-	-
-	-	-	-
-	-	-	-
-	-	-	-
-	-	-	-

www.fciconnect.com			surface ISO 1302	tolerance std ISO 406 ISO 1101	projection MM
			TOLERANCES UNLESS OTHERWISE SPECIFIED		⊕
Dr	M JACOB	2013-06-10	ANGULAR	0.X ±X	size A4
Eng	M JACOB	2013-06-10	LINEAR	0.XX ±0.2	Scale 1.000
Chr	M JACOB	2013-06-10	0° ±2°	0.XXX ±X	ECN -
Appr	BIJU K PAUL	2013-06-10	Product family		Spec ref -
FCJ			title ASSEMBLY, 2 POS HDR TYPE ROTATABLE BOARD TO BOARD CONNECTOR		no 10120045-200C
			catalog no : 10120045-200LF		Rev. A
					CUSTOMER DRAWING sheet 3 of 3