

Recommended P.C. Board Layout
SCALE 4:1

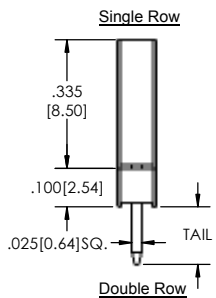

APPLICATION

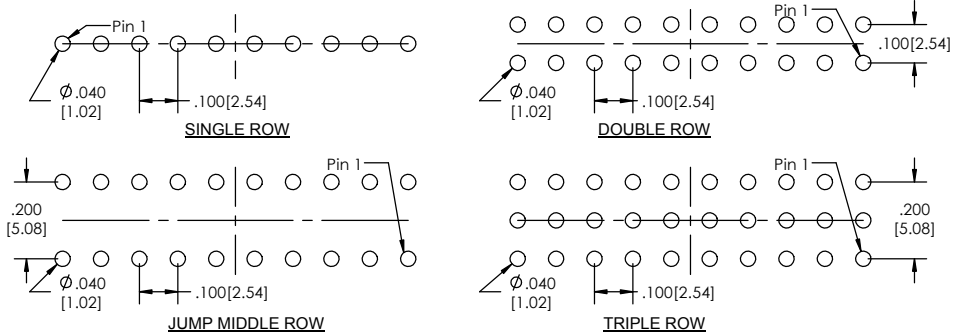
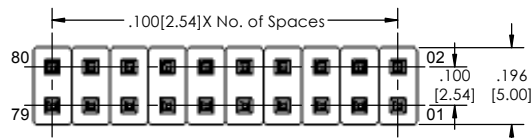
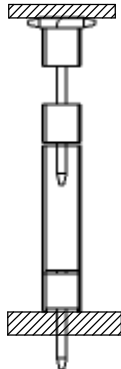

Jump Middle Row

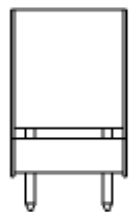

Triple Row

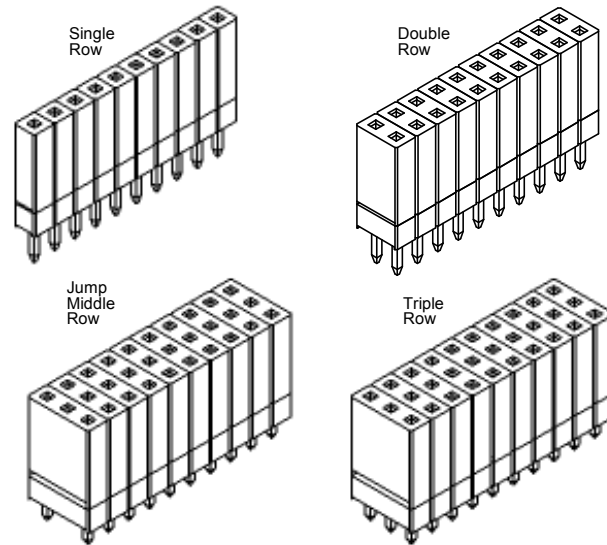
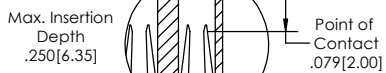
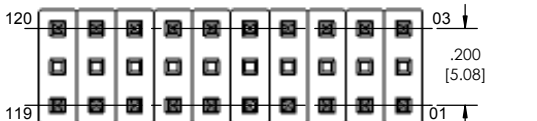
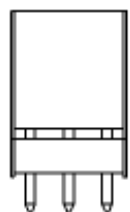

BSSQ-1 **XX** - **X** - **XX** - **XX** - **XX** - **XXX** - **LF**
(A) (B) (C) (D) (E) (F) (G)

- A. Pins Per Row - 1 through 40
- B. Row Specification
 - S= Single Row
 - D= Double Row
 - J= Jump Middle Row
 - T= Triple Row
- C. Pin Options - See Pin Options Below
- D. Plating Options - See Plating Options Below
- E. Lock Tight "LT" (Optional)
 - Leave Blank if not needed
 - LT= With
- F. Polarized Position
 - Leave Blank if not needed
 - If Required, Specify Empty Pin Position
 - e.g. 012 for Pin 12
- G. Lead Free

Specifications:
 Insertion Depth: .145(3.68mm) to .250(6.35mm)
 Insertion Force- Per Contact- H Plating
 6oz. (1.67N) avg with .025(0.64mm) sq. pin
 Withdrawal Force- Per Contact- H Plating:
 5oz. (1.39N) avg with .025(0.64mm) sq. pin
 Current Rating: 3.0 Ampere
 Insulation Resistance: 1000M Ohms Min.
 Dielectric Withstanding: 600V AC
 Contact Resistance: 20M Ohms Max.
 Operation Temperature: -40°C to +105°C
 Max. Process Temperature
 Peak: 260°C up to 20 secs.
 Process: 230°C up to 60 secs.
 Wave: 260°C up to 6 secs.
 Manual Solder: 350°C. up to 5 secs.

Materials:
 Contact Material: Phosphor Bronze
 Insulator Material: Nylon 6T
 Plating: Au or Sn over 50µ" (1.27) Ni

Tails may be clipped to achieve specific dimensions.
 Products cut to specific sizes are uncancelable/nonreturnable.
 Parts are subject to change without notice.

Pin Options		
Tail Length	Body Height	
0.090 2.29mm		02
0.290 7.37mm		04
0.490 12.47mm	0.435 11.05mm	06
0.190 4.83mm		08
0.390 9.91mm	0.535 13.59mm	10
0.090 2.29mm		12
0.290 7.37mm	0.635 16.13mm	14
0.190 4.83mm	0.735 18.67mm	16

Plating options	
G	-10µ Gold on Contact Area/ Flash on Tail
T	-Matte Tin all Over
GT	-10µ Gold on Contact Area/ Matte Tin on Tail
H	-30µ Gold on Contact Area/ Matte Tin on Tail
F	-Gold Flash over Entire Pin
FT	-Gold Flash on Contact Area/ Matte Tin on Tail



PROPRIETARY AND CONFIDENTIAL
 THE INFORMATION CONTAINED IN THIS DRAWING IS THE SOLE PROPERTY OF Major League Electronics. ANY REPRODUCTION IN PART OR AS A WHOLE WITHOUT THE WRITTEN PERMISSION OF Major League Electronics IS PROHIBITED.

UNLESS OTHERWISE SPECIFIED:		NAME		DATE
DIMENSIONS ARE IN INCHES		DRAWN	EOW	01/20/15
TOLERANCES:		CHECKED	GWG	01/20/15
ONE DECIMALS ±.100		ENG APPR.		
TWO DECIMAL ±.100		MFG APPR.		
THREE DECIMAL ±.005		ADDRESS:		
FOUR DECIMAL ±.002		2533 Centennial Blvd. Jeffersonville, In 47130 Phone: 812-670-4174 Fax: 812-670-4175 E-Mail: mle@mlelectronics.com		
NEXT ASSY	USED ON	MATERIAL		TITLE: BSSQ-1 Series
APPLICATION	DO NOT SCALE DRAWING	FINISH		SIZE DWG. NO.
INTERPRET GEOMETRIC TOLERANCING PER:				REV C
SCALE: 4:1				SHEET 1 OF 1

