

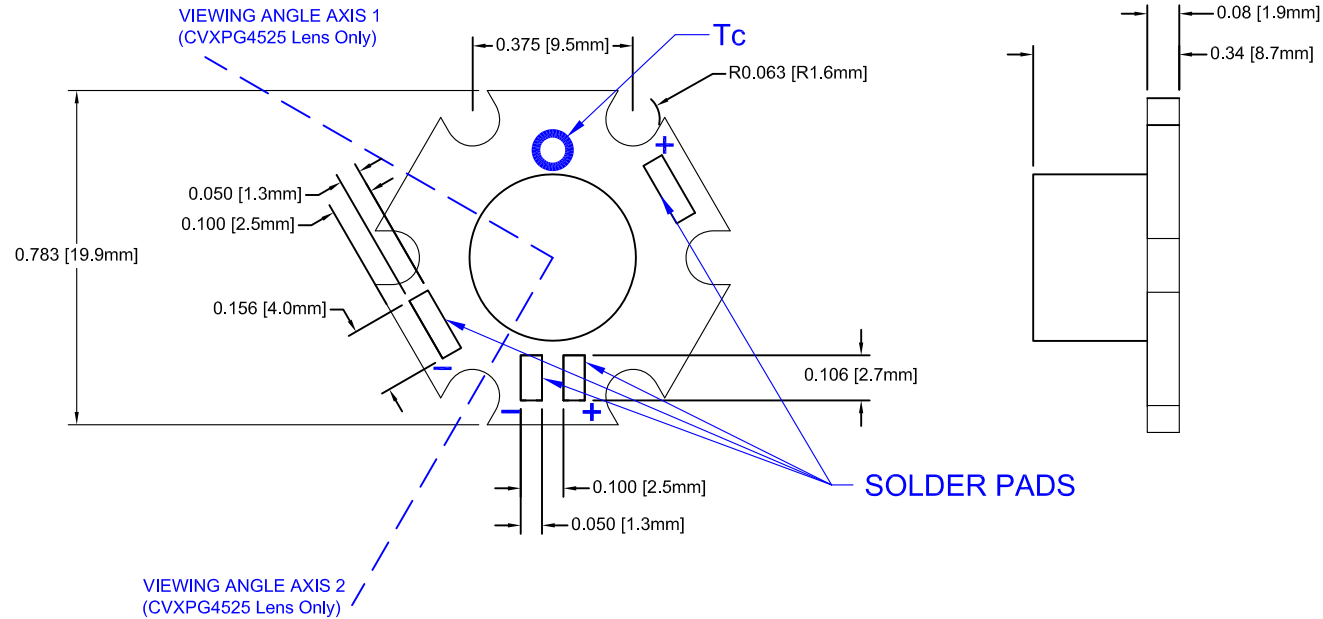

REV.	DESCRIPTION	DATE	APPROVED
G	Engineering Release.	10/03/12	T. Y.



Part Number	CCT (K)	CRI	Typical Luminous Flux @ If = 350mA, Tc=70C (lm)	Typical Luminous Flux @ If = 600mA, Tc=100C (lm)	Typical DC Forward Current, Vf (V)	Viewing Angle, Axis 1 / Axis2 (°)
L2-PGC1-S	6500	75	97	152	2.9 ~ 3.0	85
L2-PGC2-S	6500	75	97	152	2.9 ~ 3.0	35
L2-PGC3-S	6500	75	97	152	2.9 ~ 3.0	45 / 25
L2-PGN1-S	4100	75	91	142	2.9 ~ 3.0	85
L2-PGN2-S	4100	75	91	142	2.9 ~ 3.0	35
L2-PGN3-S	4100	75	91	142	2.9 ~ 3.0	45 / 25
L2-PGW1-S	3100	80	80	125	2.9 ~ 3.0	85
L2-PGW2-S	3100	80	80	125	2.9 ~ 3.0	35
L2-PGW3-S	3100	80	80	125	2.9 ~ 3.0	45 / 25

Part Number	CCT (K)	CRI	Typical Luminous Flux @ If = 1000mA, Tc=120C (lm)	Typical Luminous Flux @ If = 1500mA, Tc=100C (lm)	Typical DC Forward Current, Vf (V)	Viewing Angle, Axis 1 / Axis2 (°)
L2-PGC1-S	6500	75	216	660	3.2 ~ 3.3	85
L2-PGC2-S	6500	75	216	660	3.2 ~ 3.3	35
L2-PGC3-S	6500	75	216	660	3.2 ~ 3.3	45 / 25
L2-PGN1-S	4100	75	186	566	3.2 ~ 3.3	85
L2-PGN2-S	4100	75	186	566	3.2 ~ 3.3	35
L2-PGN3-S	4100	75	186	566	3.2 ~ 3.3	45 / 25
L2-PGW1-S	3100	80	155	472	3.2 ~ 3.3	85
L2-PGW2-S	3100	80	155	472	3.2 ~ 3.3	35
L2-PGW3-S	3100	80	155	472	3.2 ~ 3.3	45 / 25

STANDARD TOLERANCE (UNLESS OTHERWISE SPECIFIED)		 BIVAR [®] 4 THOMAS, IRVINE, CA. 92618 TEL: (949) 951-8808 FAX: (949) 951-3974
DECIMALS	ANGULAR	
.X ± .1	X° ± 1°	
.XX ± .02		TITLE: L2 Starboard Light Engine PART NO: L2-PGXX-S REVISION: G
.XXX ± .010		
DESIGNED: Brian Oliver	DATE: 11/02/11	CAGE CODE : 32559 SHEET # 1 OF 1 CAD GENERATED DOCUMENT, DO NOT MEASURE DRAWING.
CHECKED: M. Chen	DATE: 11/02/11	