

REVISIONS					
P	LTR	DESCRIPTION	DATE	DWN	APVD
	B	REVISED PER ECN-21-102793	23APR2021	RZ	WK

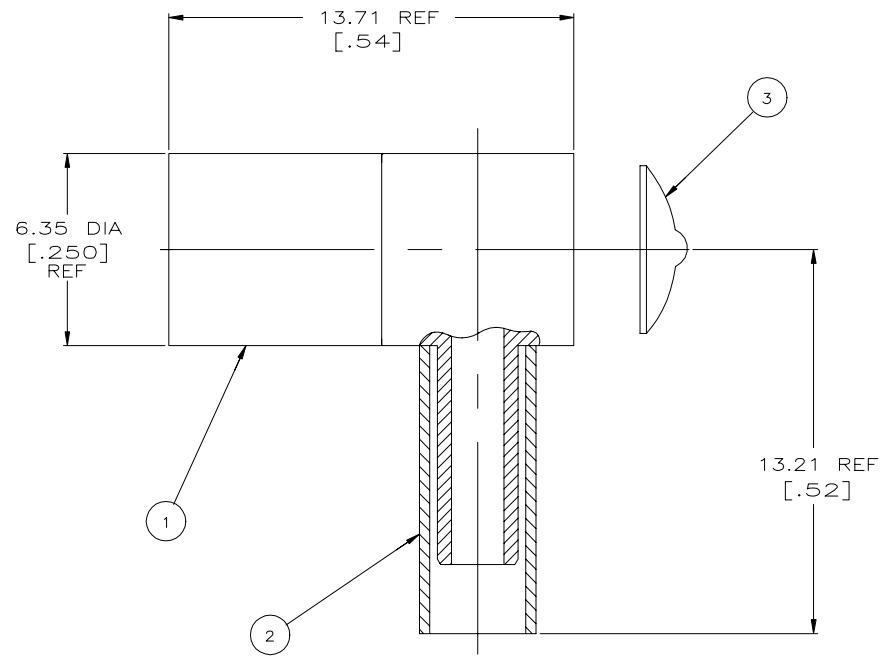

1. INTERFACE PER MIL-C-39012.
2. SEE INSTRUCTION SHEET 408-2987-9.

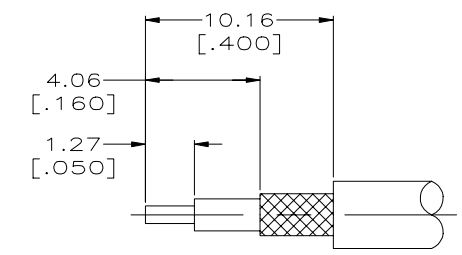

RECOMMENDED STRIP LENGTHS SCALE NTS

A	58483-1	.105	HX4-1637	414013-3	1-413889-5	9-414364-2	RG 178,196	5414363-8
B	58483-1	.128	HX4-1637	414013-3	3-413889-5	9-414364-1	RG 174,188,316	5414363-5
C	58483-1	.151	HX4-1637	414013-3	3-413889-6	9-414364-0	RG 174,188,316(ALL DBL SHIELDED)	5414363-4
B	58483-1	.128	HX4-1637	414013-3	3-413889-5	9-414364-0	RG 174,188,316	5414363-3
POSITION LETTER	AMP DIE SET	HEX SIZE	DANIELS DIE SET	③ END CAP QTY=1	② FERRULE QTY=1	① PLUG ASSY QTY=1	CABLE	PART NO
PRO-CRIMPER FOR BRAID CRIMP				M 22520/5-01 FOR BRAID CRIMP				

TOOLING INFORMATION

THIS DRAWING IS A CONTROLLED DOCUMENT.

DIMENSIONS: mm [INCHES]	TOLERANCES UNLESS OTHERWISE SPECIFIED:
	0 PLC ± -
	1 PLC ± -
	2 PLC ± 0.25 [.010]
	3 PLC ± 0.130 [.005]
	4 PLC ± - ± 1°
MATERIAL	FINISH
-	-

DWN J. HAVENER 23MAR2005	TE Connectivity NAME PLUG,RTANG CRIMP,HEX CRIMP,SMB	SIZE	CAGE CODE	DRAWING NO	RESTRICTED TO
CHK J. HAVENER 23MAR2005		A3	00779	©=5414363	-
APVD J. HAVENER 23MAR2005		CUSTOMER DRAWING			
PRODUCT SPEC		SCALE 8:1	SHEET 1 of 1	REV B	