

LOC		DIST		REVISIONS			
GP	00	REV	DATE	BY	CHK	APPV	
B		REVISED PER ECO-08-007327	17APR08	BM	WM		

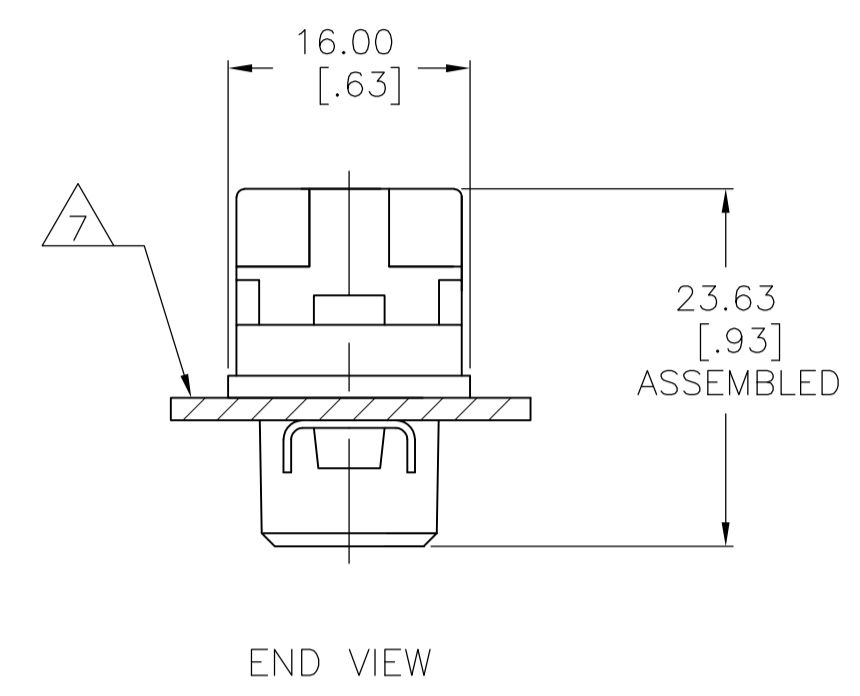

1. THE CONTACT SURFACES OF THE TERMINALS ARE COATED WITH LUBRICANT.
2. MATERIAL:  
 HOUSING & COVER: PLYPHENYLENE OXIDE (BLACK).  
 TERMINALS: PHOS BRONZE PLATED WITH EITHER 0.76μm [0.00030] MINIMUM GOLD PLATE OR GOLD FLASH OVER PALLADIUM NICKEL PLATE, 0.76μm [0.00030] MIN TOTAL ON MATING SURFACE. GOLD FLASH PLATED ON TERMINATING SIDE. 1.27μm [0.00050] MINIMUM NICKEL UNDERPLATE OVER ENTIRE TERMINAL.  
 EMI SHIELD: NICKEL PLATED DIE CASTING.  
 STUD RECEIVER: STAINLESS STEEL.
3. COVER SHOWN LOOSE BUT SHIPPED ASSEMBLED.
4. WIRE RANGE: 26 AWG SOLID THRU 30 AWG SOLID AND 28 AWG STRANDED RIBBON CABLE.
5. FLAT CABLE SHALL BE FURNISHED BY CUSTOMER.
6. MATING FACE CONSISTS OF TWO ROWS OF TERMINALS ON 2.16 [0.085] CENTERS. TERMINATING SIDE CONSISTS OF TERMINALS ON 2.54 [0.100] CENTERS FOR AN EFFECTIVE 1.27 [0.050] TERMINATION.
7. PANEL THICKNESS RANGE: 1.58 [0.062] MAX.
8. HOLES TO BE TAPPED AFTER PLATING.
9. ALL DIMENSIONS SHOWN ARE MAXIMUM UNLESS OTHERWISE SPECIFIED.

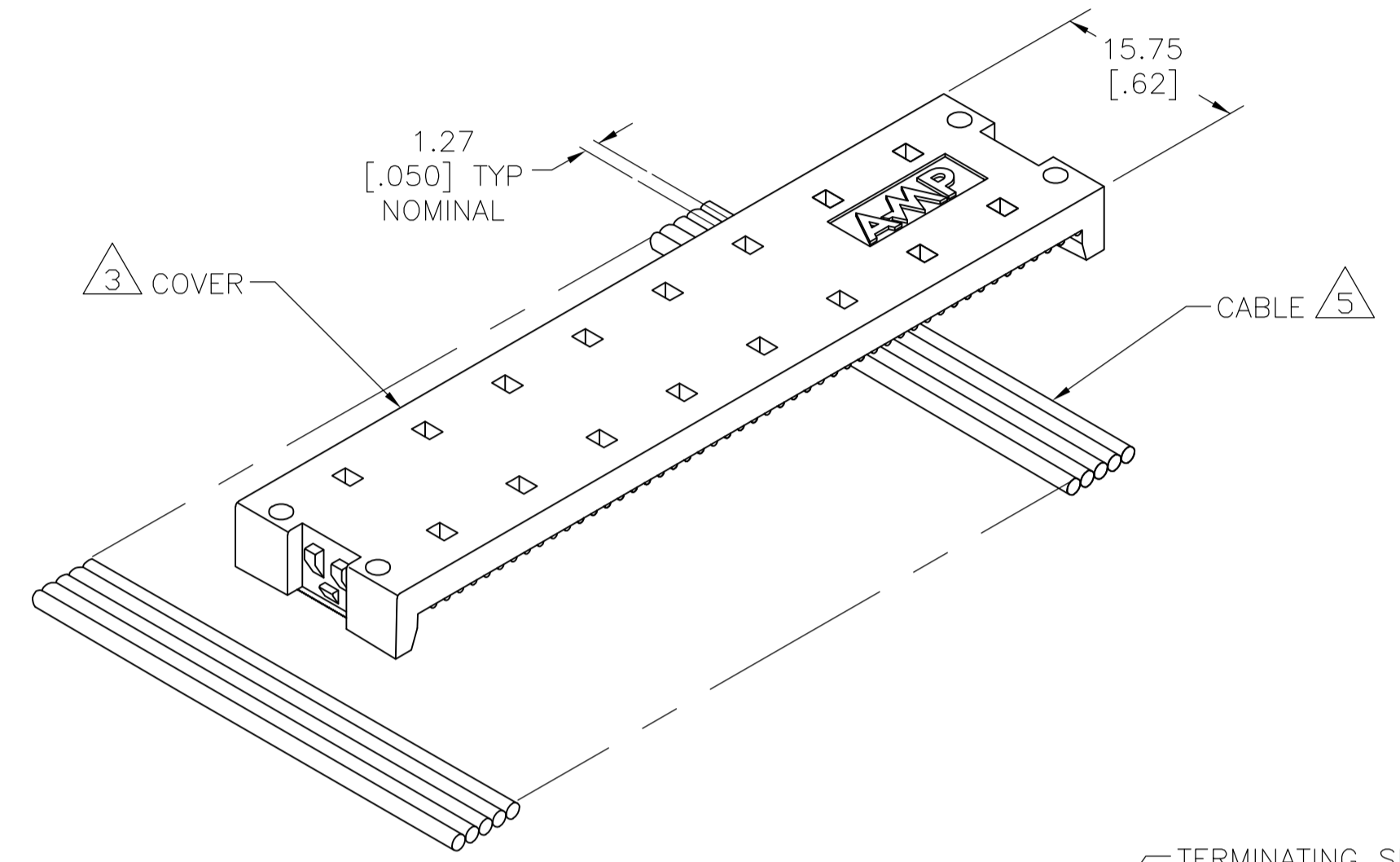
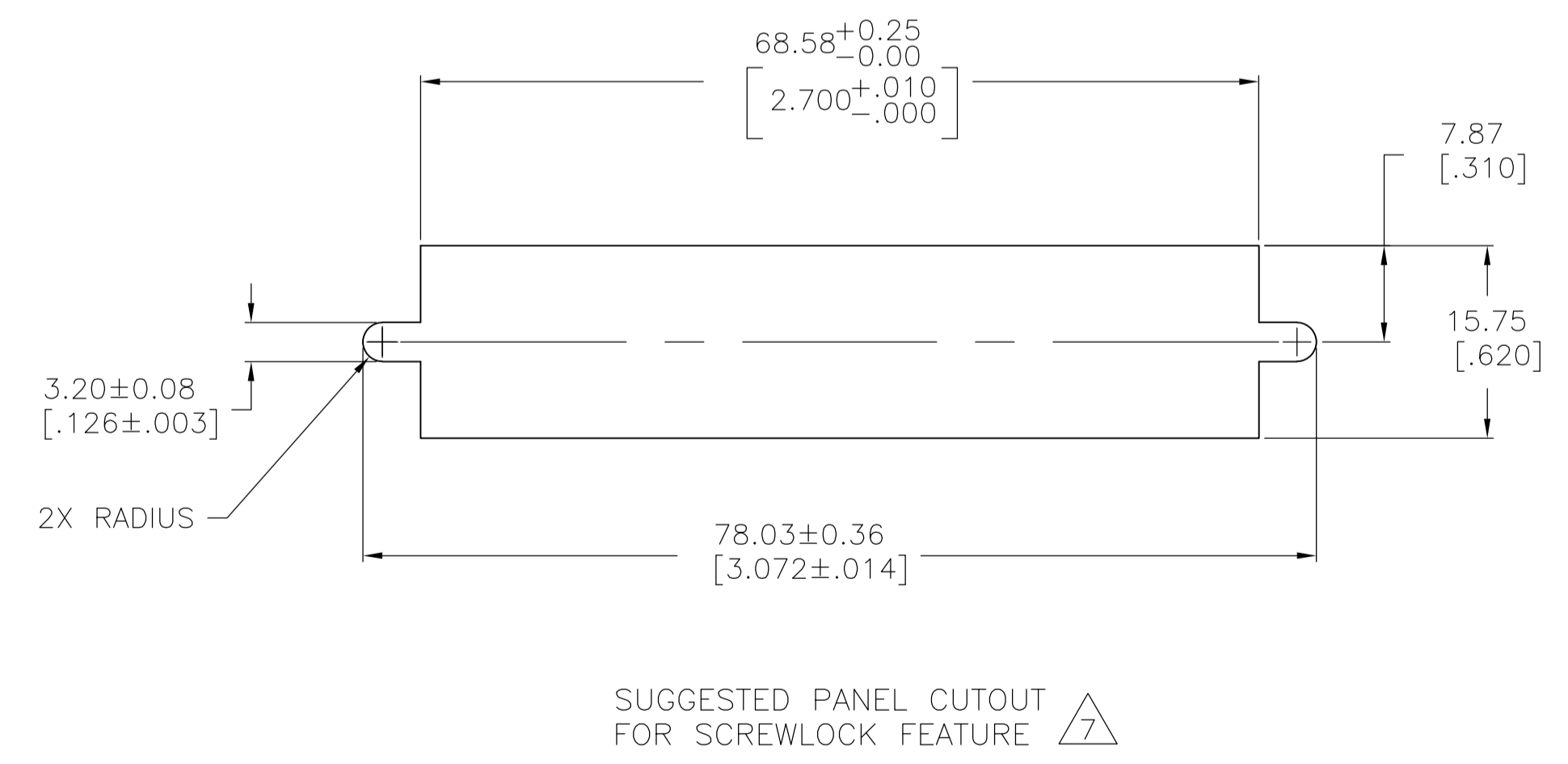
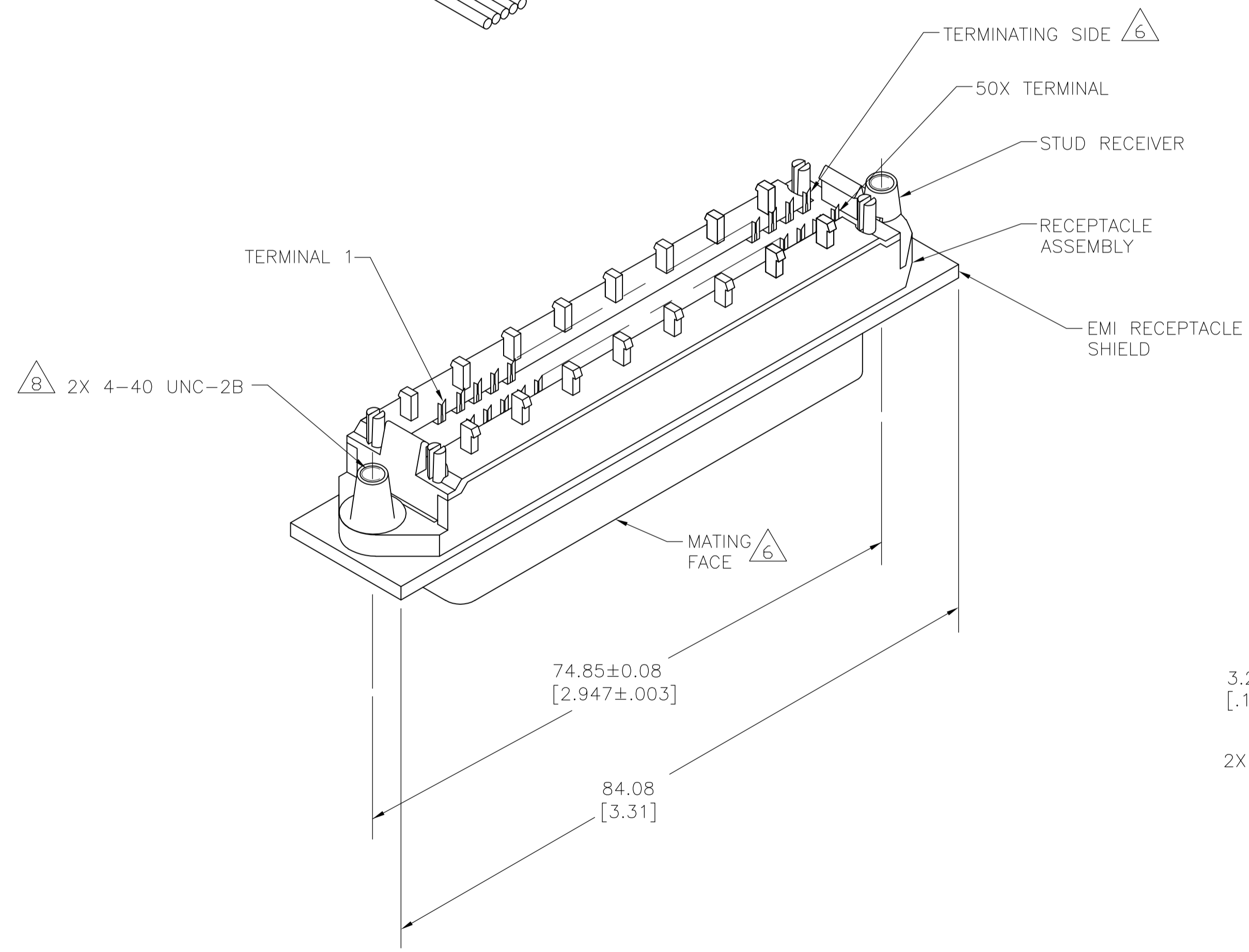

5554436-2  
PART NUMBER

THIS DRAWING IS A CONTROLLED DOCUMENT.		DWG: B1	11OCT05	Tyco Electronics Corporation Harrisburg, PA 17105-3608
DIMENSIONS: mm [INCHES]		CHK: W	11OCT05	
TOLERANCES UNLESS OTHERWISE SPECIFIED:		APPV: W	11OCT05	EMI RECEPTACLE ASSEMBLY, 50 POSITION, LOW PROFILE, SHIELDED, SCREW LOCK, CHAMP LATCH
0. PLC ± -		PRODUCT SPEC		
1. PLC ± -		APPLICATION SPEC		SIZE: A1
2. PLC ± -		WEIGHT		CAGE CODE: 5554436
3. PLC ± -		CUSTOMER DRAWING		SCALE: 2:1
4. PLC ± -				SHEET: 1 OF 1
ANGLES ± -				REV: B