

LOC		DIST		REVISIONS			
P	LTR	DESCRIPTION	DATE	DWN	APVD		
B		REV PER ECD 13-009673	6-25-13	CT	DE		

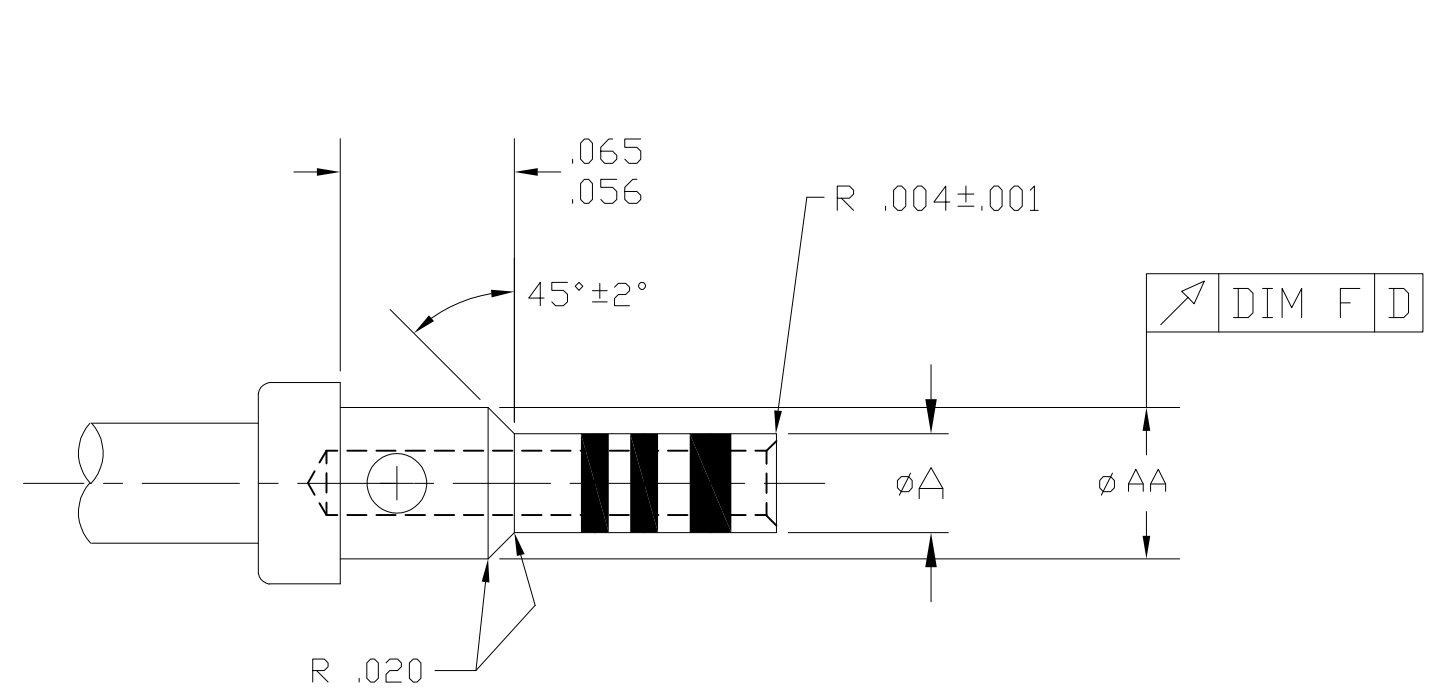

3-592404-1
SIZE 22

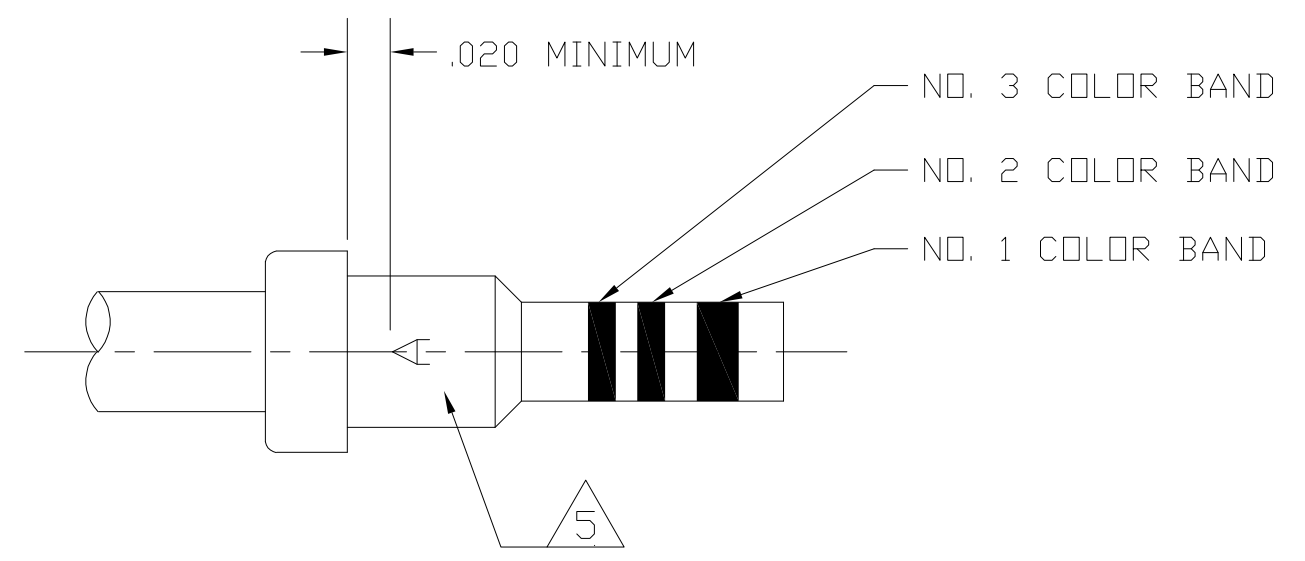

BAND IDENTIFICATION $\triangle 3$

- $\triangle 1$ FINISH: GOLD PLATE PER MIL-G-45204, TYPE I, GRADE C .000050/.000100 THK OVER NICKEL PER QQ-N-290, MATTE FINISH .000050/.000150 THK.
- $\triangle 2$ MATERIAL: BRASS PER ASTM B 16, 1/2 H
- $\triangle 3$ CONTACTS SHALL BE COLOR CODED WITH THREE BANDS ON CRIMP BARREL AT APPROXIMATE LOCATION SHOWN.
- $\triangle 4$ MATERIAL: LEADED COPPER PER ASTM-B-301, CONDITION H.
- $\triangle 5$ GOTHIC "A" .016±.002 HIGH STAMPED .001/.002 DEEP.
- $\triangle 6$ NOTE 1 APPLIES TO MATING END ONLY. REMAINDER OF PIN IS GOLD STRIKE OVER NICKEL. (2-592404-1 ONLY)

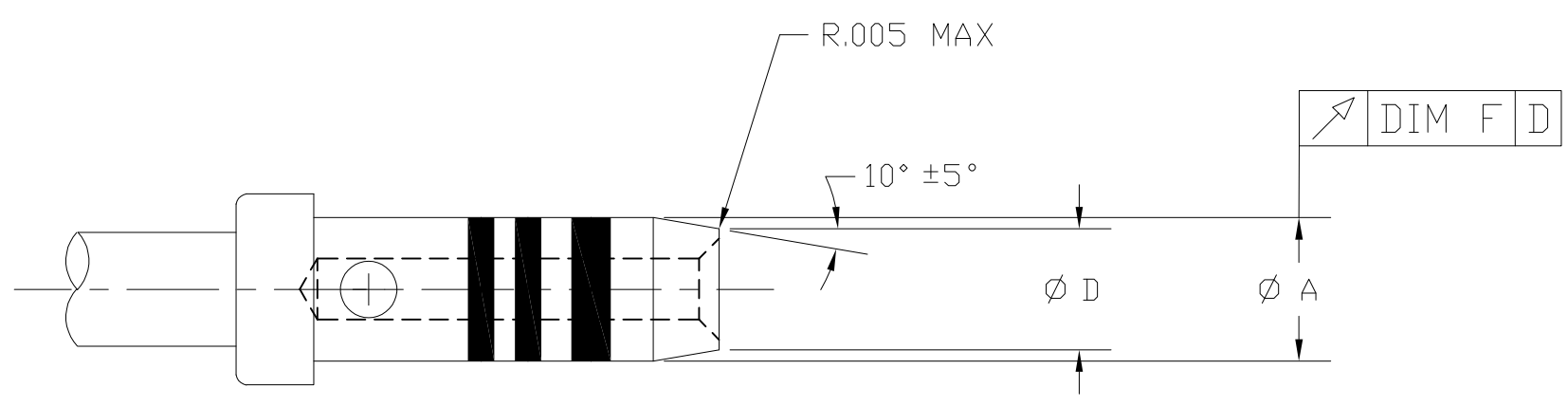

1-592404-1
SIZE 16

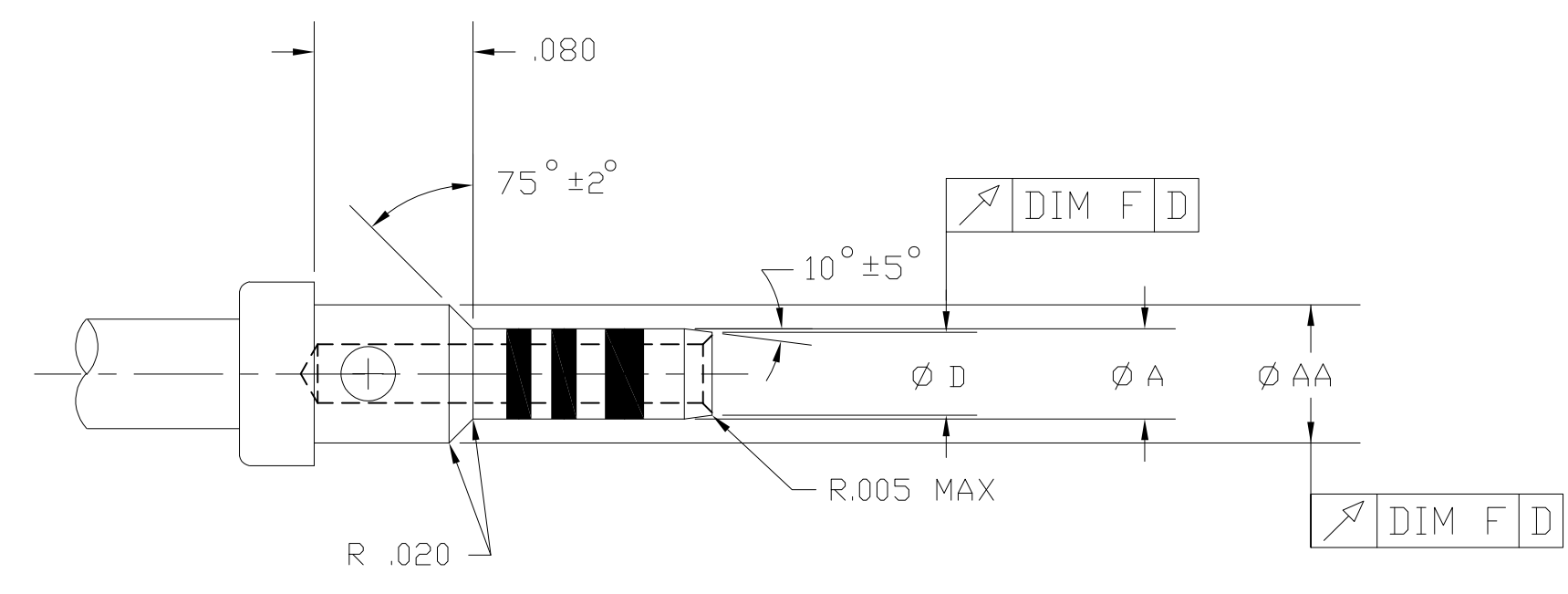

592404-1
SIZE 12

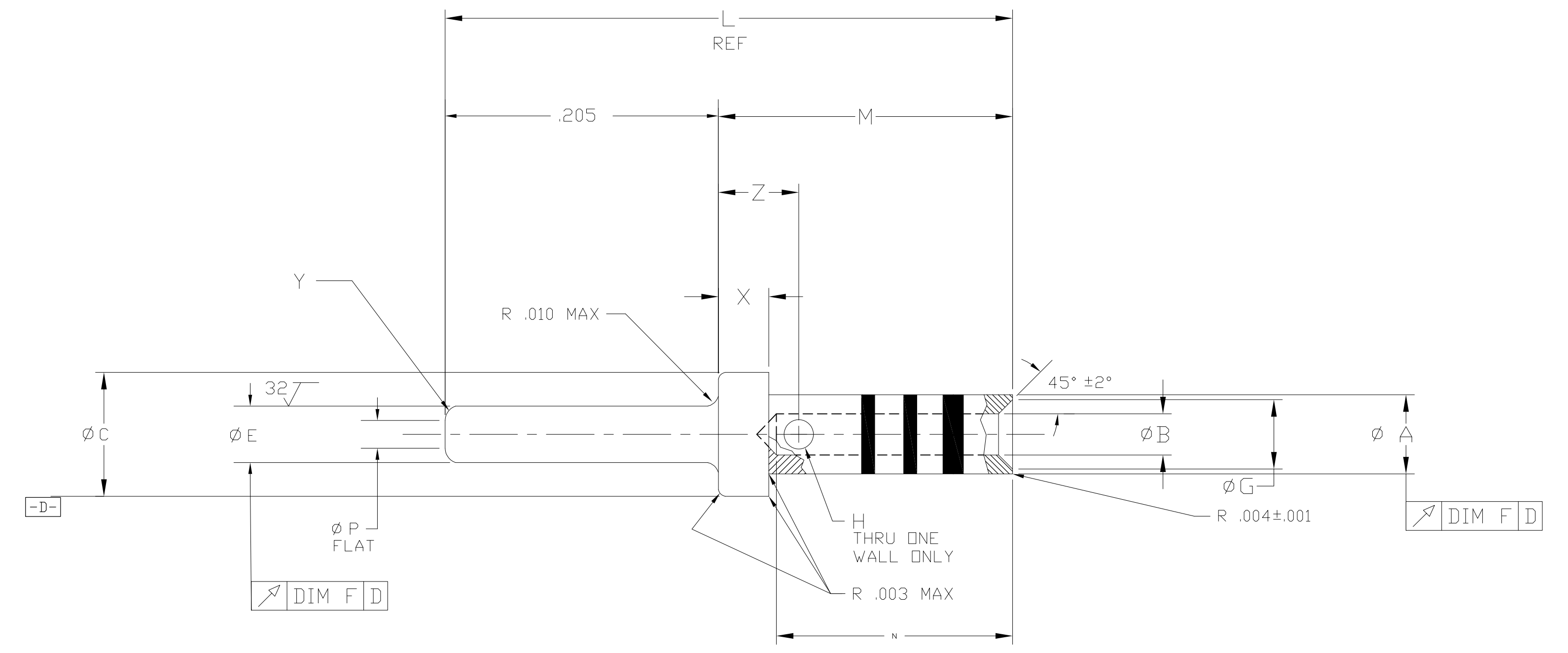

2-592404-1
SIZE 20

REMARKS	MATERIAL	COLOR BAND NO. 3	COLOR BAND NO. 2	COLOR BAND NO. 1	DIM. P	DIM. J	DIM. K	DIM. F	DIM. D	DIM. AA	DIM. Z	DIM. Y	DIM. X	DIM. N	DIM. M	DIM. L	DIM. H	DIM. G	DIM. E	DIM. C	DIM. B	DIM. A	PART NO.
		$\triangle 2$	$\triangle 3$	$\triangle 4$.017/.032	.124	.025	.005	—	.076/.078	.057/.063	.015/.025	.029/.033	.157/.186	.211/.215	.418	.018/.022	.042/.046	.061/.063	.100/.103	.035/.037	.048/.051	3-592404-1
		$\triangle 6$	$\triangle 2$	$\triangle 4$.017/.032	.124	.025	.005	—	—	.057/.063	.015/.025	.029/.033	.157/.186	.211/.215	.418	.026/.032	.060/.064	.061/.063	.100/.103	.048/.050	.076/.078	2-592404-1
		$\triangle 2$	$\triangle 2$	$\triangle 4$.024/.039	.144	.050	.006	.086/.092	—	.073/.079	.025/.035	.044/.048	.250/.281	.294/.298	.501	.036/.042	.080/.090	.076/.078	.130/.133	.066/.068	.101/.105	1-592404-1
		$\triangle 2$	$\triangle 2$	$\triangle 4$.047/.062	.094	.050	.006	.130/.136	.155/.158	.073/.079	.035/.045	.044/.048	.250/.281	.294/.298	.501	.036/.042	.115/.125	.093/.095	.187/.190	.098/.102	.147/.153	592404-1

THIS DRAWING IS A CONTROLLED DOCUMENT.

DWN	N. FRITZ	3-23-95
CHK	S. WRIGHT	3-24-95
APVD	S. WRIGHT	3-24-95

TE Connectivity

PIN CONTACT, CRIMP, TJ

SIZE: CAGE CODE: DRAWING NO: RESTRICTED TO

SCALE: 10:1 SHEET 1 OF 1 REV B