

PART NUMBER	REV	FIRST USED	POWER UNIT	FEED TYPE
1852156-1	1	122500-1	LEADMAKER & BENCH MODEL G	POST FEED
1852156-2	1	565435-5	BENCH MODEL K	POST FEED
7-1852156-7	1	-	SPARE PARTS	-

- △ RECOMMENDED SPARE PARTS
- △ GREASE LIGHTLY
- △ GUARD MUST BE IN PLACE WHEN OPERATING APPLICATOR IN A BENCH MACHINE

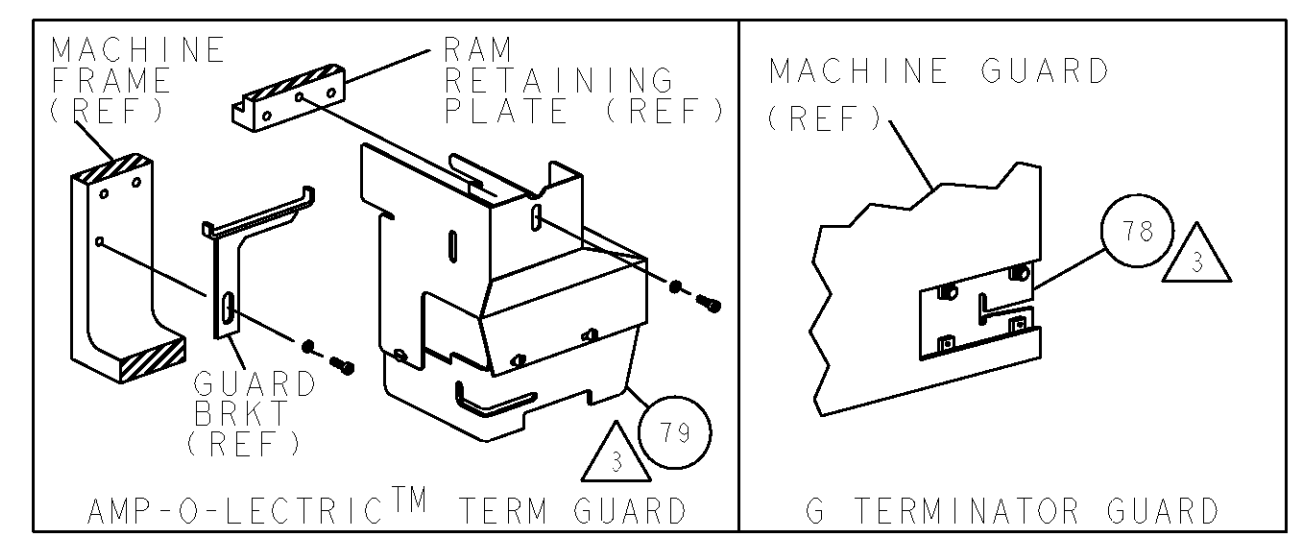

TERMINAL NAME: FEMALE TAB				
TYCO #	COMP #	INTER LOCK TERMINAL - AMP CRIMP SPECS		
1572861-1	JDJ-2030-2			
		PAD LTR	CRIMP HEIGHT	WIRE SIZE
		A	.054±.002 [1.37±0.05mm]	20
		B	-	-
		C	-	-
		D	-	-
		CRIMP	SIZE	TYPE RANGE
		WIRE	.080 [2.03mm]	F 20AWG
		INSUL	.110 [2.79mm]	F -
WIRE STRIP LENGTH	TERM APPL SPEC	FEED	APPL INSTRUCTIONS	SET UP GAGE
.187 -.202	NONE	.830	408-8040	458637-1

LOC	DIST	REVISIONS					
A	66	P	LTR	DESCRIPTION	DATE	DWN	APPR
		-	-		26FEB2004	-	-

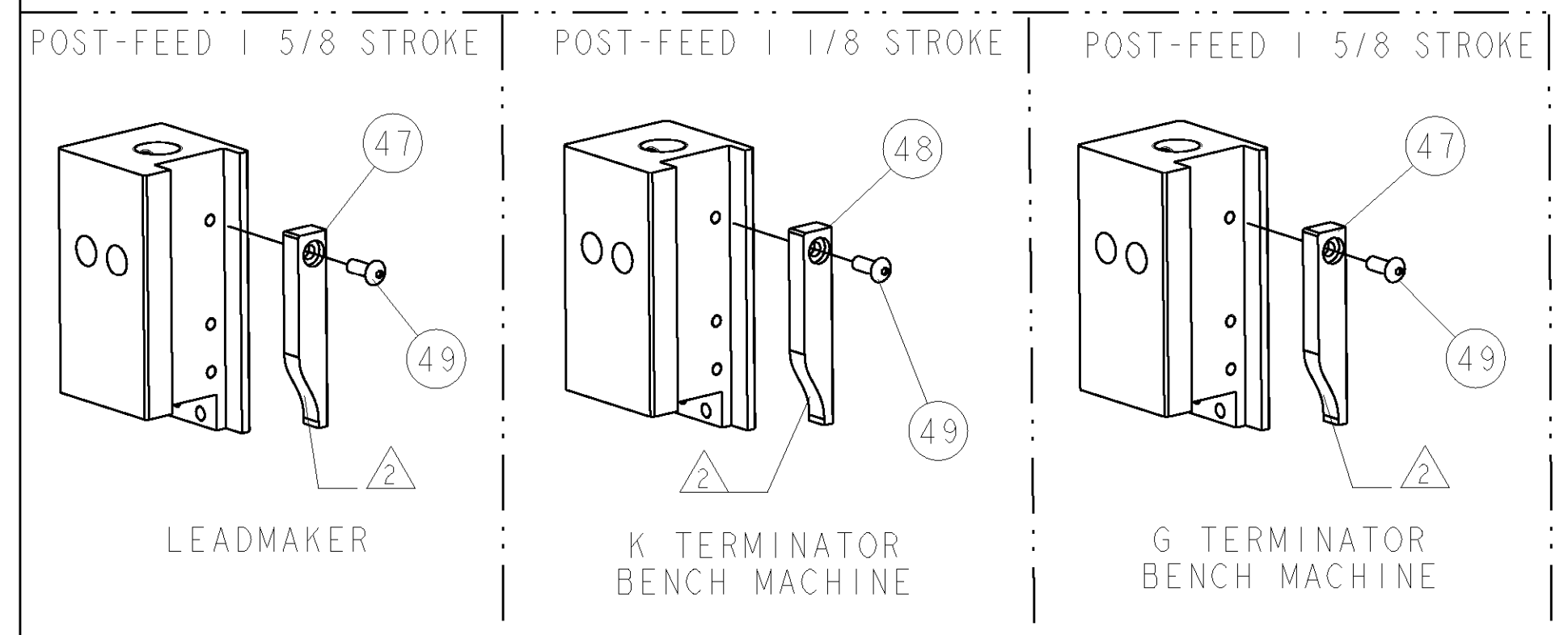
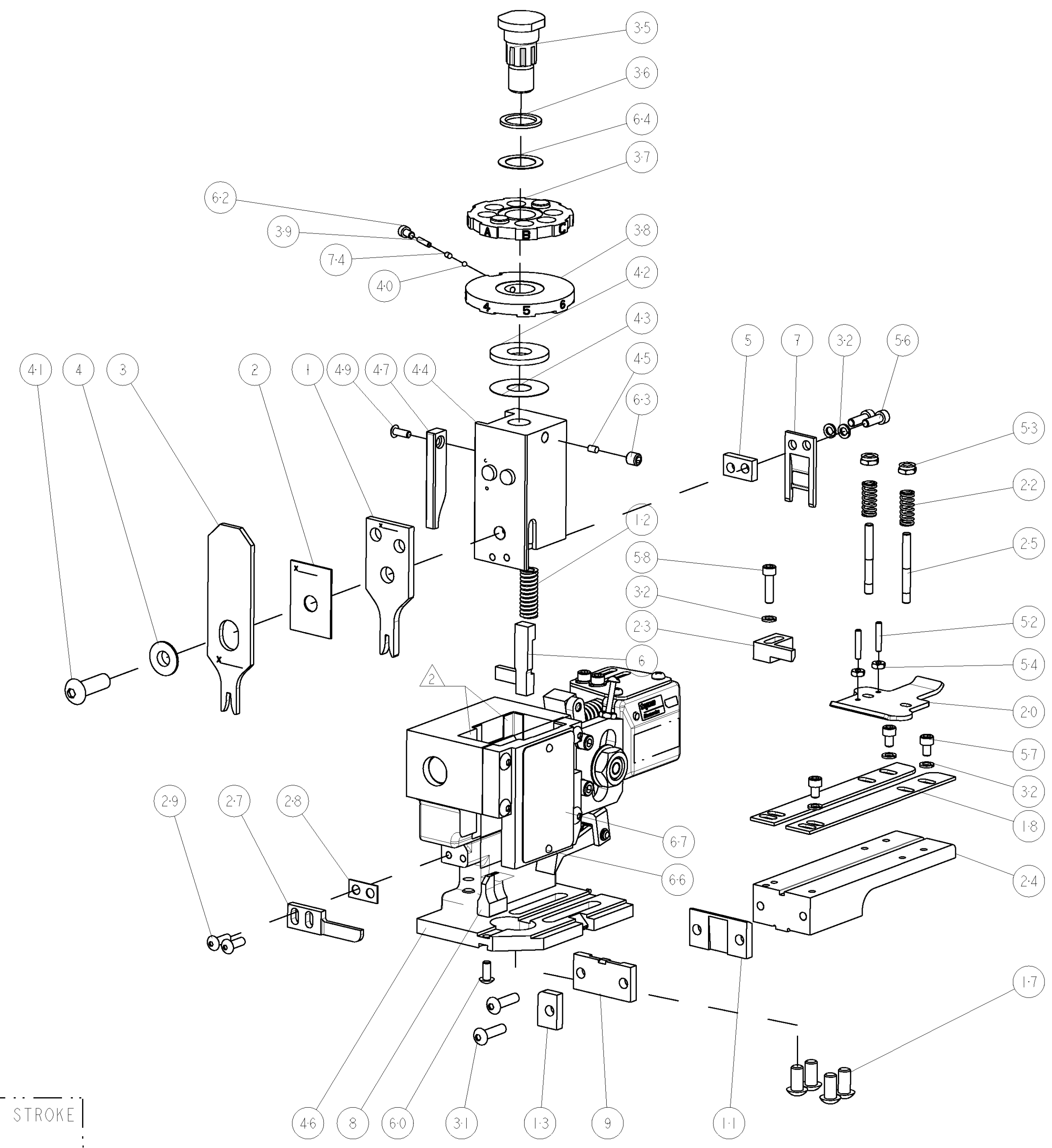
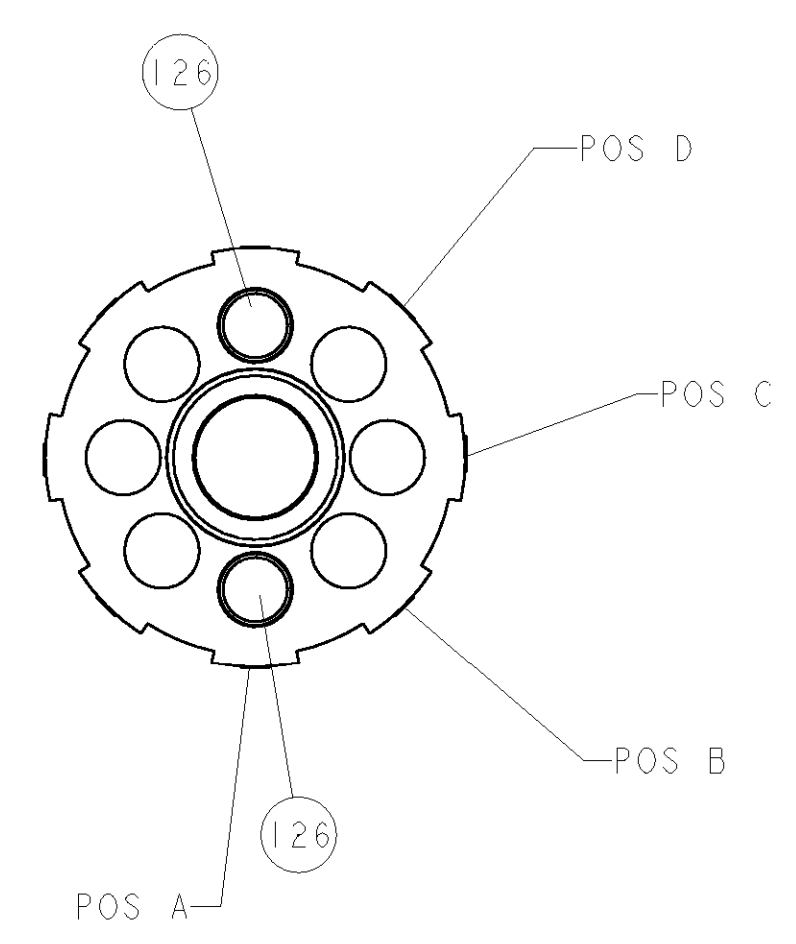

-	2	2	-	2-354779-2	PIN, WIRE DISC, .3100	126
-	REF	-	-	455749-1	GUARD WINDOW	79
-	-	REF	-	679532-1	INSERT, GUARD	78
-	1	1	-	690603-1	SPRING ASSIST AMP-O-MATOR APPLICATOR	74
-	1	1	-	217238-1	GENERAL INSTRUCTION PKG	72
-	1	1	-	4088039	EF APPL INST 408-8039	71
-	1	1	-	461264-1	PLATE, IDENTIFICATION	67
-	2	2	-	21017-2	SCREW, DRIVE	66
-	1	1	-	986950-1	WASHER, FLAT PRECISION	64
-	1	1	-	21009-2	SCR, SET, SELF LOCKING 1/4-20 X .250	63
-	1	1	-	23030-1	SCR, SKT HD CAP 6-32 X .25	62
-	1	1	-	22733-8	SCR, BHSC, SELF-LOCKING, 8-32 X .375	60
-	1	1	-	2-21000-8	SCR, SKT HD CAP 8-32 X .625	58
-	3	3	-	2-21000-5	SCR, SKT HD CAP 8-32 X .250	57
-	2	2	-	2-21000-7	SCR, SKT HD CAP 8-32 X .500	56
-	2	2	-	21018-4	NUT, HEX, REG 4-40	54
-	2	2	-	21022-2	NUT, LOCK, HEX, TORQUE, 8-32	53
-	2	2	-	2-21006-6	SCR, SET, CUP POINT 4-40 X .625	52
-	1	1	-	1-21002-7	SCR, BTN SKT HD CAP 6-32 X .375	49
-	1	-	-	690501-3	CAM, POST FEED, 1 1/8	48
-	-	-	-	690501-4	CAM, POST-FEED 1 5/8	47
-	1	1	-	458980-1	SUB ASSY, APPLICATOR FRAME	46
-	1	1	-	690191-1	PLUG, NYLON	45
-	1	1	-	455674-1	RAM	44
-	1	1	-	690125-1	SHIM SUB-ASSY	43
-	1	1	-	690124-1	WASHER, RAM (.115)	42
-	1	1	-	7-21002-9	SCR, BTN SKT HD CAP 5/16-24 X 1.00	41
-	1	1	-	23241-6	BALL, STEEL	40
-	1	1	-	690170-1	SPRING, COMPRESSION	39
-	1	1	-	690142-1	DISC, INSULATION	38
-	1	1	-	354777-1	WIRE DISC, ASSEMBLY	37
-	1	1	-	22480-5	SPRING, COMPRESSION	36
-	1	1	-	690212-1	POST, RAM	35
-	6	6	-	21024-4	WASHER, SPRG LOCK, REG NO 8	32
-	2	2	-	2-21002-9	SCR, BTN SKT HD CAP 10-32 X .750	31
-	2	2	-	2-21002-2	SCR, BTN SKT HD CAP 8-32 X .500	29
-	1	1	-	1-690451-7	SPACER, STRIPPER	28
-	1	1	-	240639-1	STRIPPER (MACHINING)	27
-	2	2	-	22354-8	STUD, THREADED	25
-	1	1	-	458803-5	PLATE, STRIP GUIDE	24
-	1	1	-	240825-2	PLATE, STRIP HOLD DOWN	23
-	2	2	-	4-22281-1	SPRING, DRAG	22
-	1	1	-	454177-1	DRAG	20
-	2	2	-	454204-1	GUIDE, LOWER STRIP	18
-	4	4	-	3-21002-3	SCR, BTN SKT HD CAP 1/4-20 X .500	17
-	1	1	-	690481-2	SPACER, HOLD DOWN	13
-	1	1	-	23846-1	SPRING, DIE	12
-	1	1	-	240833-4	PLATE, REAR SHEAR	11
-	1	1	-	690482-1	PLATE, FRONT SHEAR	9
-	1	1	-	1633249-3	ANVIL, COMBINATION	8
-	1	1	-	690474-2	BLADE, SLUG	7
-	1	1	-	1-455892-4	HOLD DOWN, TERMINAL	6
-	1	1	-	5-240641-0	SPACER	5
-	1	1	-	1-238009-3	BLOCK, FL CRIMPER SPACER	4
-	1	1	-	1-1424909-1	CRIMPER, INSULATION F	3
-	1	1	-	455888-7	SPACER, CRIMPER	2
-	1	1	-	2-456405-7	CRIMPER, WIRE PREMIUM	1

DIMENSIONS:		TOLERANCES UNLESS OTHERWISE SPECIFIED:		DRAWN		DATE		DESCRIPTION		ITEM NO
INCHES		0 PLC	±	B. HIGMAN	09NOV2005	tyco		Tyco Electronics		
		1 PLC	±0.1	B. HIGMAN	09NOV2005	Electronics		Harrisburg, PA 17105-3608		
		2 PLC	±0.01			NAME		END FEED HDM APPLICATOR		
		3 PLC	±0.001			PRODUCT SPEC				
		4 PLC	±0.0001			APPLICATION SPEC				
		ANGLES	±			WEIGHT				
MATERIAL		FINISH				SCALE		3:5		
						CAGE CODE		00779		
						DRAWING NO		C=1852156		
						RESTRICTED TO				
						SHEET		1 OF 1		
						REV				

CUSTOMER VIEWABLE ASSEMBLY