

DO NOT
SCALE FROM
THIS PRINT

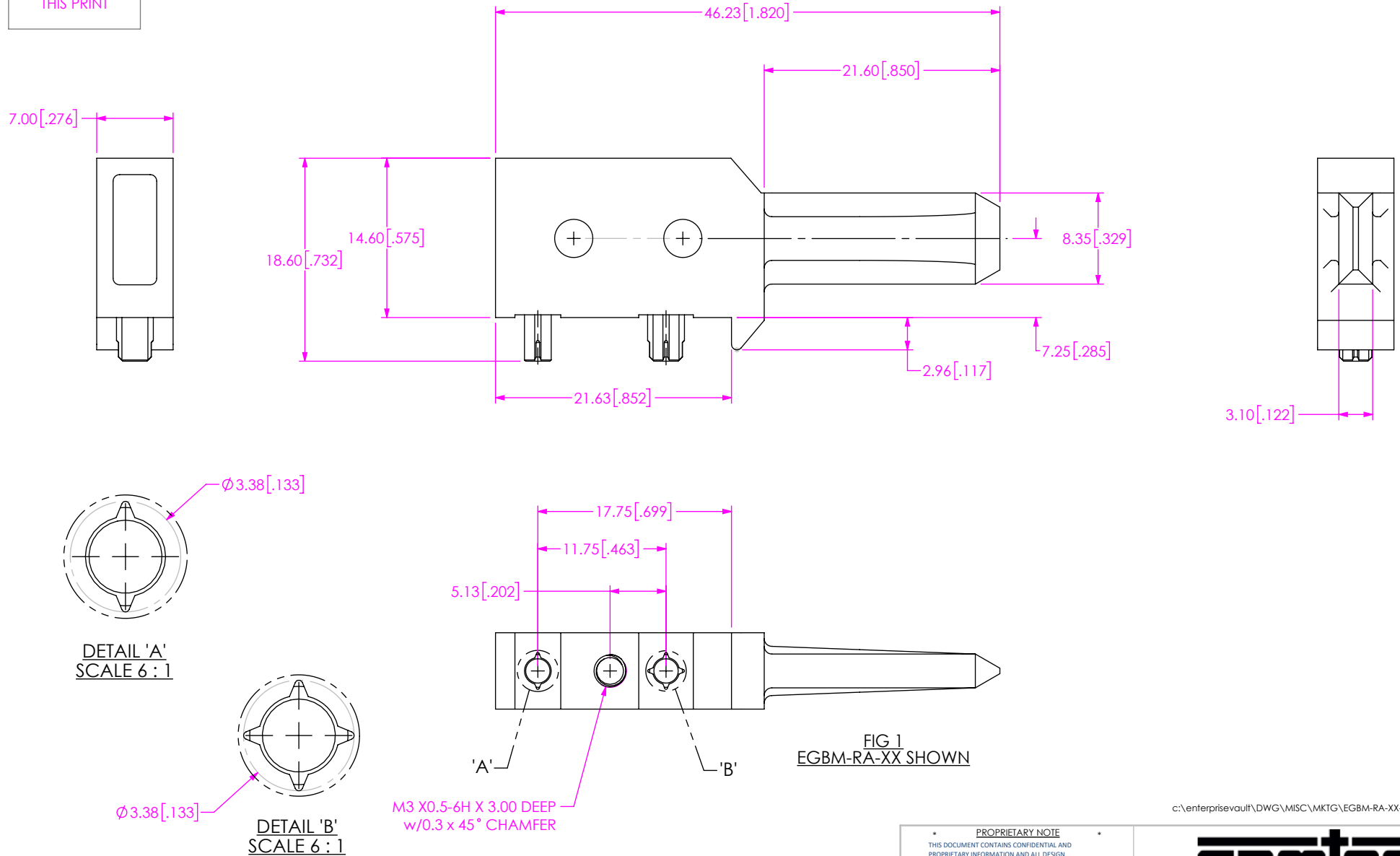

FIG 1
EGBM-RA-XX SHOWN

c:\enterprisevault\DWG\MISC\MKTG\EGBM-RA-XX-MKT.SLDDRW

NOTES:

1. STANDARD PACKAGING: USE ASBBLT6X8.5 BAG, 100 PCS MAXIMUM.
2. ASSEMBLIES TO BE FREE OF MAJOR SCRATCHES OR NICKS.
3. SEE EGBM-RA-XX FOOTPRINT DRAWING FOR RECOMMENDED PCB LAYOUT AND INFORMATION REGARDING PCB LAYOUT OF GUIDE MODULES RELATIVE TO SIGNAL MODULES.
4. NOMINAL PCB THICKNESS: 1.6mm [.062] MINIMUM.
5. NOTE DELETED.
6. NOTE DELETED.

<p>PROPRIETARY NOTE</p> <p>THIS DOCUMENT CONTAINS CONFIDENTIAL AND PROPRIETARY INFORMATION AND ALL DESIGN, MANUFACTURING, REPRODUCTION, USE, PATENT RIGHTS AND SALES RIGHTS ARE EXPRESSLY RESERVED BY SAMTEC, INC. THIS DOCUMENT SHALL NOT BE DISCLOSED, IN WHOLE OR PART, TO ANY UNAUTHORIZED PERSON OR ENTITY NOR REPRODUCED, TRANSFERRED OR INCORPORATED IN ANY OTHER PROJECT IN ANY MANNER WITHOUT THE EXPRESS WRITTEN CONSENT OF SAMTEC, INC.</p>	<p>DO NOT SCALE DRAWING SHEET SCALE: 1:2</p>	
	<p>DESCRIPTION: EXAMAX™ RIGHT ANGLE GUIDE BLADE</p>	
	<p>DWG. NO. EGBM-RA-XX</p>	
<p>MATERIAL: ZINC ALLOY FINISH: ZINC YELLOW CHROMATE</p>	<p>BY: B BLESSING 3/22/2018 SHEET 1 OF 1</p>	



520 PARK EAST BLVD. NEW ALBANY, IN 47150
PHONE: 812-944-6733 FAX: 812-948-5047
e-Mail info@SAMTEC.com code 55322