

HD6303R, HD63A03R, HD63B03R CMOS MPU (Micro Processing Unit)

The HD6303R is an 8-bit CMOS micro processing unit which has the completely compatible instruction set with the HD6301V1. 128 bytes RAM, Serial Communication Interface (SCI), parallel I/O ports and multi function timer are incorporated in the HD6303R. It is bus compatible with HMCS6800 and can be expanded up to 65k bytes. Like the HMCS6800 family, I/O level is TTL compatible with +5.0V single power supply. As the HD6303R is CMOS MPU, power dissipation is extremely low. And also HD6303R has Sleep Mode and Stand-by Mode as lower power dissipation mode. Therefore, flexible low power consumption application is possible.

■ FEATURES

- Object Code Upward Compatible with the HD6800, HD6801, HD6802
- Multiplexed Bus ($D_0/A_0 \sim D_7/A_7, A_8 \sim A_{15}$). Non Multiplexed Bus ($D_0 \sim D_7, A_0 \sim A_{15}$)
- Abundant On-Chip Functions Compatible with the HD6301V1; 128 Bytes RAM, 13 Parallel I/O Lines, 16-bit Timer, Serial Communication Interface (SCI)
- Low Power Consumption Mode; Sleep Mode, Stand-By Mode
- Minimum Instruction Execution Time
 $1\mu s$ ($f=1\text{MHz}$), $0.67\mu s$ ($f=1.5\text{MHz}$), $0.5\mu s$ ($f=2.0\text{MHz}$)
- Bit Manipulation, Bit Test Instruction
- Error Detecting Function; Address Trap, Op Code Trap
- Up to 65k Bytes Address Space
- Wide Operation Range
 $V_{CC} = 3$ to $6V$ ($f = 0.1 \sim 0.5 \text{ MHz}$)
 $f = 0.1$ to 2.0 MHz ($V_{CC} = 5V \pm 10\%$)

■ TYPE OF PRODUCTS

Type No.	Bus Timing
HD6303R	1.0 MHz
HD63A03R	1.5 MHz
HD63B03R	2.0 MHz

■ PROGRAM DEVELOPMENT SUPPORT TOOLS

- Cross assembler and C compiler software for IBM PCs and compatibles
- In circuit emulator for use with IBM PCs and compatibles

HD6303RP, HD63A03RP,
HD63B03RP

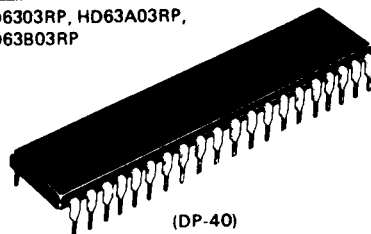

HD6303RF, HD63A03RF,
HD63B03RF

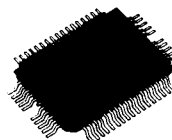

HD6303RCG, HD63A03RCG,
HD63B03RCG



HD6303RCP, HD63A03RCP
HD63B03RCP

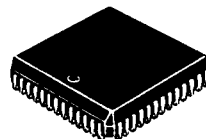

HD6303RL, HD63A03RL
HD63B03RL

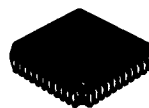

2

HD6303R, HD63A03R, HD63B03R

PIN ARRANGEMENT

- HD6303RP, HD63A03RP, HD63B03RP

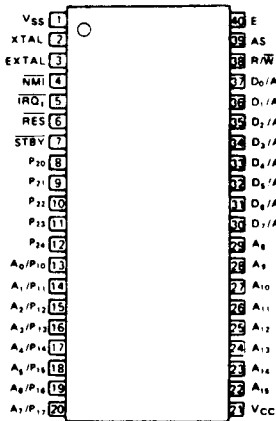

(Top View)

- HD6303RF, HD63A03RF, HD63B03RF

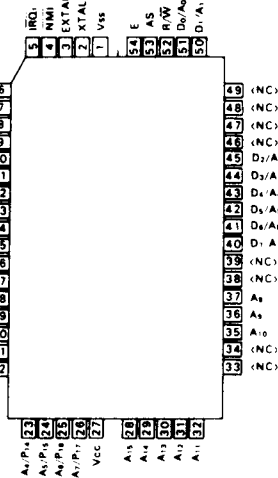

(Top View)

- HD6303RCG, HD63A03RCG, HD63B03RCG

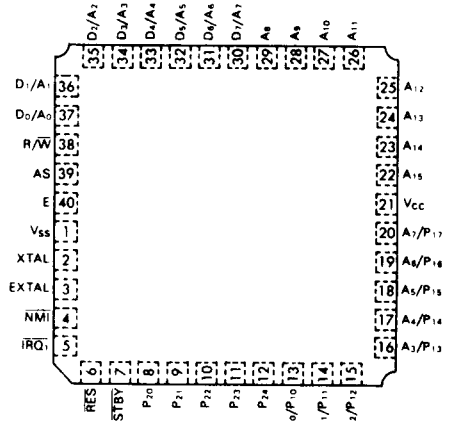

(Top View)

- HD6303RCP, HD63A03RCP, HD63B03RCP

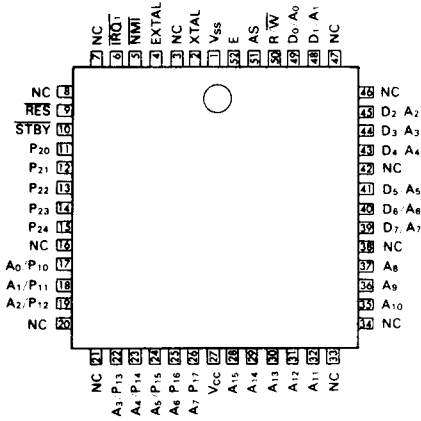

(Top View)

- HD 6303RL, HD63A03RL, HD63B03RL

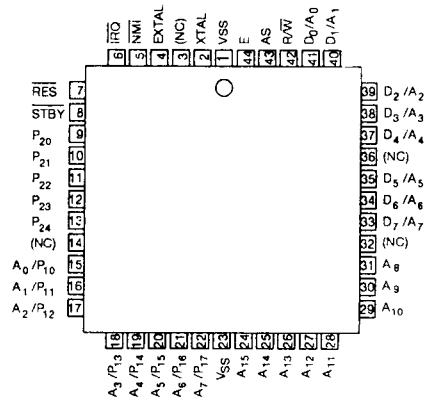

(Top View)

■ BLOCK DIAGRAM

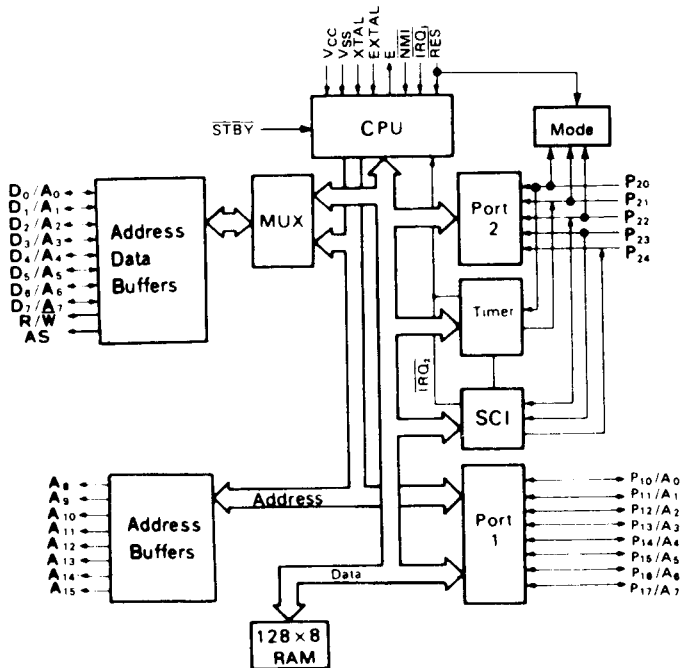

HD6303R, HD63A03R, HD63B03R

■ ABSOLUTE MAXIMUM RATINGS

Item	Symbol	Value	Unit
Supply Voltage	V_{CC}	-0.3 ~ +7.0	V
Input Voltage	V_{in}	-0.3 ~ $V_{CC}+0.3$	V
Operating Temperature	T_{opr}	0 ~ +70	°C
Storage Temperature	T_{stg}	-55 ~ +150	°C

(NOTE) This product has protection circuits in input terminal from high static electricity voltage and high electric field. But be careful not to apply overvoltage more than maximum ratings to these high input impedance protection circuits. To assure the normal operation, we recommend $V_{in}, V_{out} : V_{SS} \leq (V_{in} \text{ or } V_{out}) \leq V_{CC}$.

■ ELECTRICAL CHARACTERISTICS

- DC CHARACTERISTICS ($V_{CC} = 5.0V \pm 10\%$, $V_{SS} = 0V$, $T_a = 0 \sim +70^\circ C$, unless otherwise noted.)

Item	Symbol	Test Condition	min	typ	max	Unit	
Input "High" Voltage	RES, STBY	V_{IH}	$V_{CC}-0.5$	—	$V_{CC}+0.3$	V	
	EXTAL		$V_{CC} \times 0.7$	—			
	Other Inputs		2.0	—			
Input "Low" Voltage	All Inputs	V_{IL}	-0.3	—	0.8	V	
Input Leakage Current	NMI, IRQ ₁ , RES, STBY	$ I_{in} $	$V_{in} = 0.5 \sim V_{CC}-0.5V$	—	—	1.0	μA
Three State (off-state) Leakage Current	P ₁₀ ~P ₁₇ , P ₂₀ ~P ₂₄ , D ₀ ~D ₇ , A ₈ ~A ₁₅	$ I_{TSI} $	$V_{in} = 0.5 \sim V_{CC}-0.5V$	—	—	1.0	μA
Output "High" Voltage	All Outputs	V_{OH}	$I_{OH} = -200\mu A$	2.4	—	—	V
			$I_{OH} = -10\mu A$	$V_{CC}-0.7$	—	—	V
Output "Low" Voltage	All Outputs	V_{OL}	$I_{OL} = 1.6mA$	—	—	0.55	V
Input Capacitance	All Inputs	C_{in}	$V_{in} = 0V, f = 1.0MHz, T_a = 25^\circ C$	—	—	12.5	pF
Standby Current	Non Operation	I_{CC}	$V_{IL}(\text{STBY}) = 0 \sim 0.6V$	—	2.0	15.0	μA
			$V_{IH}(\text{RES}) = V_{CC} - 0.5 \sim V_{CC}V$	—	—	—	
			$V_{IL}(\text{RES}) = 0 \sim 0.6V$	—	—	—	
Current Dissipation*		I_{CC}	Operating (f=1MHz)**	—	6.0	10.0	mA
			Sleeping (f=1MHz)**	—	1.0	2.0	
RAM Stand-By Voltage		V_{RAM}		2.0	—	—	V

* $V_{IH} \text{ min} = V_{CC}-1.0V, V_{IL} \text{ max} = 0.8V$

** Current Dissipation of the operating or sleeping condition is proportional to the operating frequency. So the typ. or max. values about Current Dissipations at f = x MHz operation are decided according to the following formula;

$$\begin{aligned} \text{typ. value (f = x MHz)} &= \text{typ. value (f = 1MHz)} \times x \\ \text{max. value (f = x MHz)} &= \text{max. value (f = 1MHz)} \times x \\ &\text{(both the sleeping and operating)} \end{aligned}$$



● AC CHARACTERISTICS ($V_{CC} = 5.0V \pm 10\%$, $V_{SS} = 0V$, $T_a = 0 \sim +70^\circ C$, unless otherwise noted.)

BUS TIMING

Item	Symbol	Test Condition	HD6303R			HD63A03R			HD63B03R			Unit
			min	typ	max	min	typ	max	min	typ	max	
Cycle Time	t_{cyc}		1	—	10	0.666	—	10	0.5	—	10	μs
Address Strobe Pulse Width * "High"	PW_{ASH}		220	—	—	150	—	—	110	—	—	ns
Address Strobe Rise Time	t_{ASr}		—	—	20	—	—	20	—	—	20	ns
Address Strobe Fall Time	t_{ASf}		—	—	20	—	—	20	—	—	20	ns
Address Strobe Delay Time *	t_{ASD}		60	—	—	40	—	—	20	—	—	ns
Enable Rise Time	t_{Er}		—	—	20	—	—	20	—	—	20	ns
Enable Fall Time	t_{Ef}		—	—	20	—	—	20	—	—	20	ns
Enable Pulse Width "High" Level*	PW_{EH}		450	—	—	300	—	—	220	—	—	ns
Enable Pulse Width "Low" Level*	PW_{EL}		450	—	—	300	—	—	220	—	—	ns
Address Strobe to Enable Delay* Time	t_{ASED}		60	—	—	40	—	—	20	—	—	ns
Address Delay Time	t_{AD1}	Fig. 1	—	—	250	—	—	190	—	—	160	ns
	t_{AD2}		—	—	250	—	—	190	—	—	160	ns
Address Delay Time for Latch*	t_{ADL}	Fig. 2	—	—	250	—	—	190	—	—	160	ns
Data Set-up Time	Write	t_{DSW}	230	—	—	150	—	—	100	—	—	ns
	Read	t_{DSR}	80	—	—	60	—	—	50	—	—	ns
Data Hold Time	Read	t_{HR}	0	—	—	0	—	—	0	—	—	ns
	Write	t_{HW}	20	—	—	20	—	—	20	—	—	ns
Address Set-up Time for Latch *	t_{ASL}		60	—	—	40	—	—	20	—	—	ns
Address Hold Time for Latch	t_{AHL}		30	—	—	20	—	—	20	—	—	ns
Address Hold Time	t_{AH}		20	—	—	20	—	—	20	—	—	ns
$A_0 \sim A_7$ Set-up Time Before E*	t_{ASM}		200	—	—	110	—	—	60	—	—	ns
Peripheral Read Access Time	Non-Multiplexed Bus *	(t_{ACCN})	—	—	650	—	—	395	—	—	270	ns
	Multiplexed Bus*	(t_{ACCM})	—	—	650	—	—	395	—	—	270	ns
Oscillator stabilization Time	t_{RC}	Fig. 8	20	—	—	20	—	—	20	—	—	ms
Processor Control Set-up Time	t_{PCS}	Fig. 9	200	—	—	200	—	—	200	—	—	ns

*These timings change in approximate proportion to t_{cyc} . The figures in this characteristics represent those when t_{cyc} is minimum (= in the highest speed operation).

PERIPHERAL PORT TIMING

Item	Symbol	Test Condition	HD6303R			HD63A03R			HD63B03R			Unit	
			min	typ	max	min	typ	max	min	typ	max		
Peripheral Data Set-up Time	Port 1, 2	t_{PDSU}	Fig. 3	200	—	—	200	—	—	200	—	—	ns
Peripheral Data Hold Time	Port 1, 2	t_{PDH}	Fig. 3	200	—	—	200	—	—	200	—	—	ns
Delay Time, Enable Negative Transition to Peripheral Data Valid	Port 1, 2*	t_{PWD}	Fig. 4	—	—	300	—	—	300	—	—	300	ns

* Except P₂₁.



HD6303R, HD63A03R, HD63B03R

TIMER, SCI TIMING

Item	Symbol	Test Condition	HD6303R			HD63A03R			HD63B03R			Unit
			min	typ	max	min	typ	max	min	typ	max	
Timer Input Pulse Width	t_{PWT}		2.0	-	-	2.0	-	-	2.0	-	-	t_{cyc}
Delay Time, Enable Positive Transition to Timer Out	t_{TOD}	Fig. 5	-	-	400	-	-	400	-	-	400	ns
SCI Input Clock Cycle	t_{Scyc}		2.0	-	-	2.0	-	-	2.0	-	-	t_{cyc}
SCI Input Clock Pulse Width	t_{PWSCK}		0.4	-	0.6	0.4	-	0.6	0.4	-	0.6	t_{Scyc}

MODE PROGRAMMING

Item	Symbol	Test Condition	HD6303R			HD63A03R			HD63B03R			Unit
			min	typ	max	min	typ	max	min	typ	max	
RES "Low" Pulse Width	PW_{RSTL}		3	-	-	3	-	-	3	-	-	t_{cyc}
Mode Programming Set-up Time	t_{MPS}	Fig. 6	2	-	-	2	-	-	2	-	-	t_{cyc}
Mode Programming Hold Time	t_{MPH}		150	-	-	150	-	-	150	-	-	ns

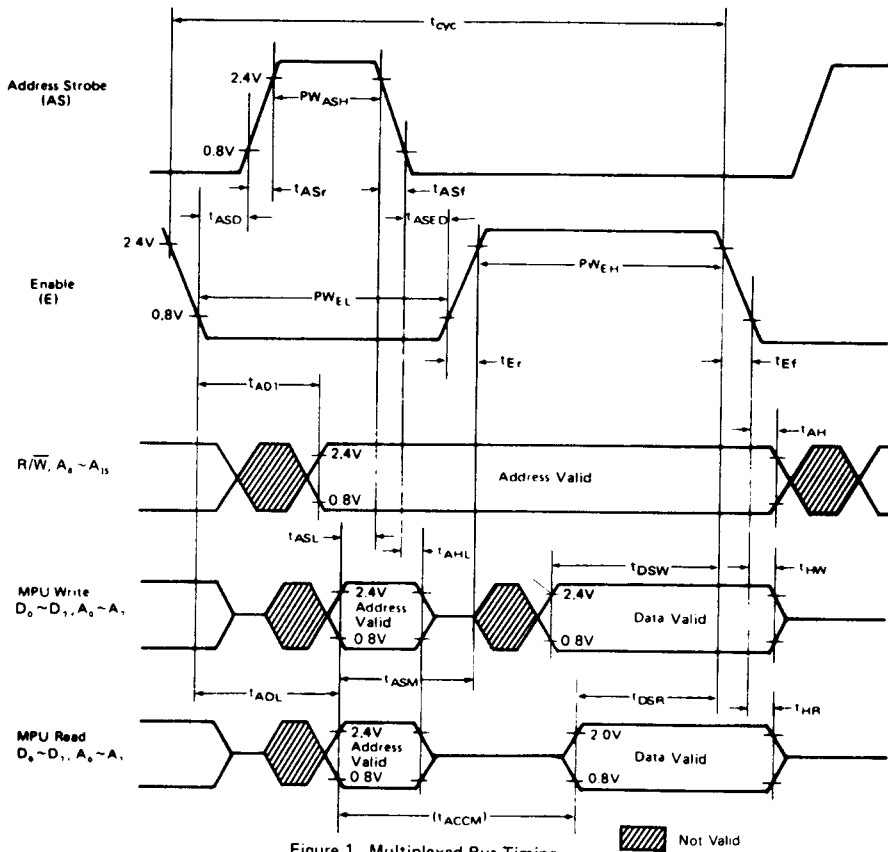

Figure 1 Multiplexed Bus Timing



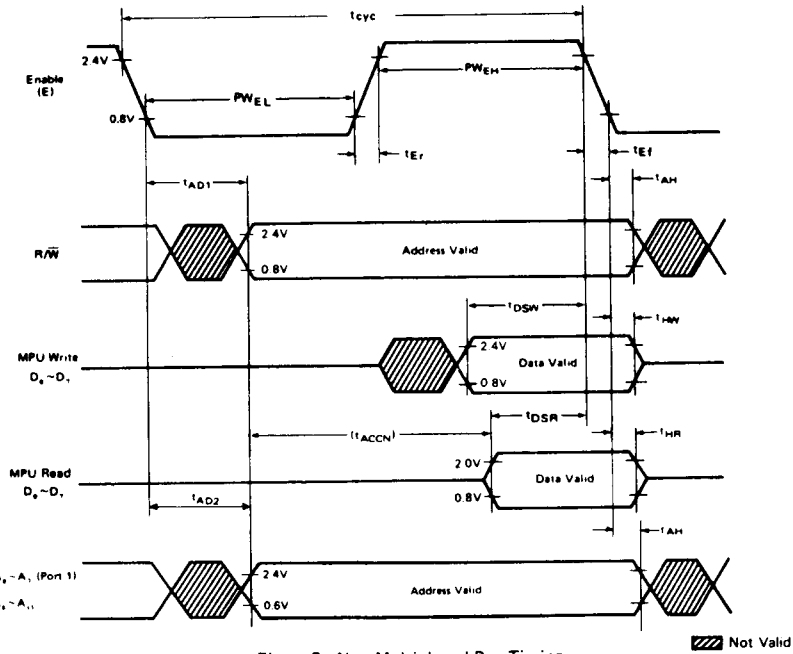

Figure 2 Non-Multiplexed Bus Timing

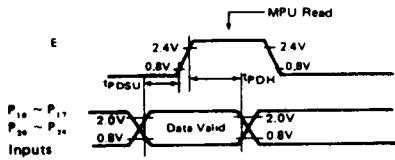
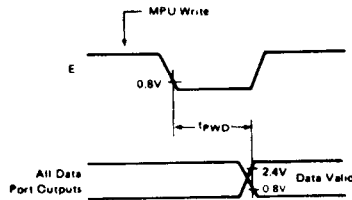

Figure 3 Port Data Set-up and Hold Times (MPU Read)



Note) Port 2: Except P₂₁
Figure 4 Port Data Delay Times (MPU Write)

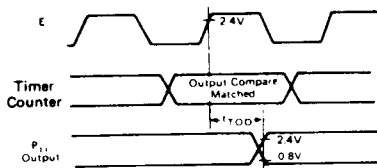

Figure 5 Timer Output Timing

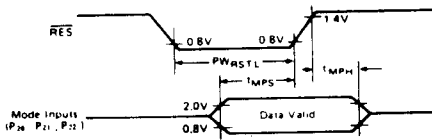

Figure 6 Mode Programming Timing

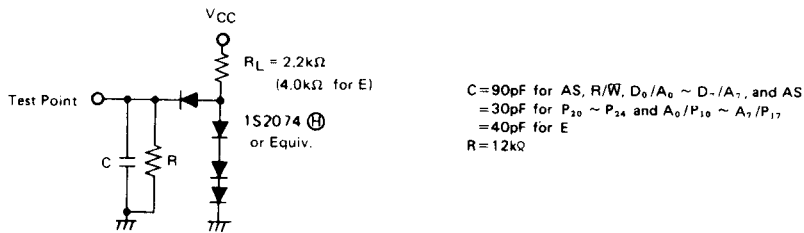

Figure 7 Bus Timing Test Loads (TTL Load)

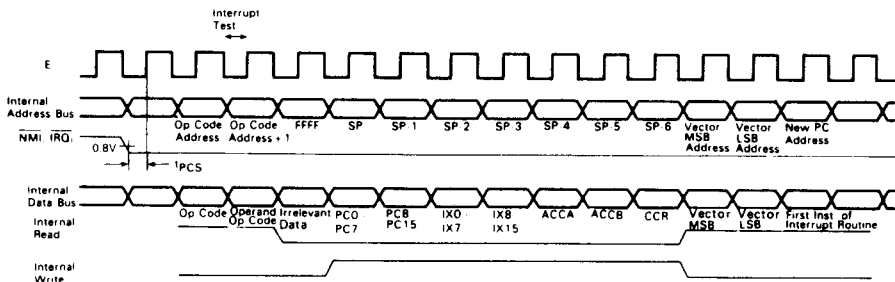

Figure 8 Interrupt Sequence

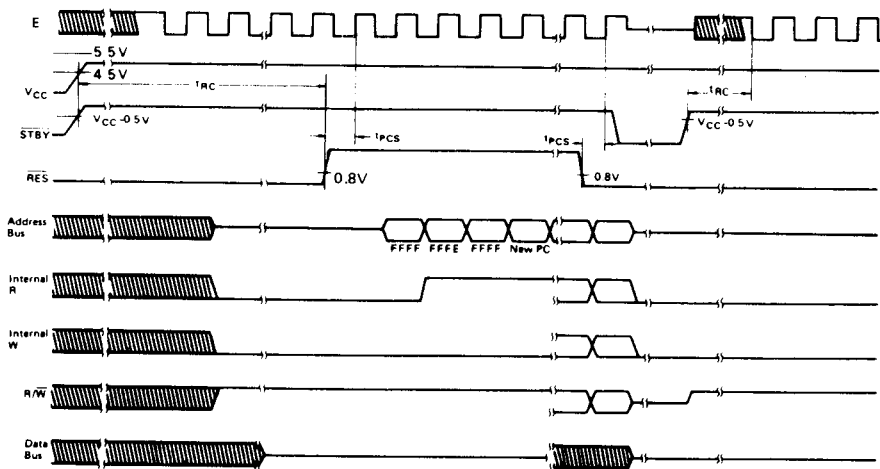

Figure 9 Reset Timing

FUNCTIONAL PIN DESCRIPTION

V_{CC}, V_{SS}

These two pins are used for power supply and GND. Recommended power supply voltage is 5V ± 10%, 3 to 6V can be used for low speed operation (100 ~ 500 kHz).

XTAL, EXTAL

These two pins are connected with parallel resonant funda-

mental crystal, AT cut. For instance, in order to obtain the system clock 1MHz, a 4MHz resonant fundamental crystal is used because the divide-by-4 circuitry is included. An example of the crystal interface is shown in Fig. 10. EXTAL accepts an external clock input of duty 45% to 55% to drive. For external clock, XTAL pin should be open. The crystal and capacitors should be mounted as close as possible to the pins.



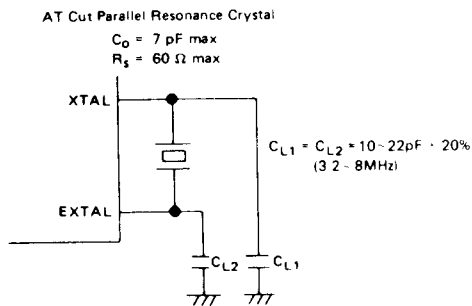

Figure 10 Crystal Interface

• **Standby (STBY)**

This pin is used to place the MPU in the standby mode. If this goes to "Low" level, the oscillation stops, the internal clock is tied to V_{SS} or V_{CC} and the MPU is reset. In order to retain information in RAM during standby, write "0" into RAM enable bit (RAME). RAME is bit 6 of the RAM Control Register at address \$0014. This disables the RAM, so the contents of RAM is guaranteed. For details of the standby mode, see the Standby section.

• **Reset (\overline{RES})**

This input is used to reset the MPU. \overline{RES} must be held "Low" for at least 20ms when the power starts up. It should be noted that, before clock generator stabilize, the internal state and I/O ports are uncertain, because MPU can not be reset without clock. To reset the MPU during system operation, it must be held "Low" for at least 3 system clock cycles. From the third cycle, all address buses become "high-impedance" and it continues while \overline{RES} is "Low". If \overline{RES} goes to "High", CPU does the following.

- (1) I/O Port 2 bits 2,1,0 are latched into bits PC2, PC1, PC0 of program control register.
- (2) The contents of the two Start Addresses, \$FFFE, \$FFFF are brought to the program counter, from which program starts (see Table 1).
- (3) The interrupt mask bit is set. In order to have the CPU recognize the maskable interrupts $\overline{IRQ_1}$ and $\overline{IRQ_2}$, clear it before those are used.

• **Enable (E)**

This output pin supplies system clock. Output is a single-phase, TTL compatible and 1/4 the crystal oscillation frequency. It will drive two LS TTL load and 40pF capacitance.

• **Non Maskable Interrupt (\overline{NMI})**

When the falling edge of the input signal of this pin is recognized, NMI sequence starts. The current instruction is continued to complete, even if \overline{NMI} signal is detected. Interrupt mask bit in Condition Code Register has no effect on NMI detection. In response to NMI interrupt, the information of Program Counter, Index Register, Accumulators, and Condition Code Register are stored on the stack. On completion of this sequence, vectoring address \$FFFC and \$FFFD are generated to load the contents to the program counter. Then the CPU branch to a non maskable interrupt service routine.

• **Interrupt Request ($\overline{IRQ_1}$)**

This level sensitive input requests a maskable interrupt sequence. When $\overline{IRQ_1}$ goes to "Low", the CPU waits until it completes the current instruction that is being executed. Then, if the interrupt mask bit in Condition Code Register is not set, CPU begins interrupt sequence; otherwise, interrupt request is neglected.

Once the sequence has started, the information of Program Counter, Index Register, Accumulator, Condition Code Register are stored on the stack. Then the CPU sets the interrupt mask bit so that no further maskable interrupts may be responded.

Table 1 Interrupt Vectoring memory map

Vector		Interrupt
MSB	LSB	
FFFE	FFFF	RES
FFEE	FFEF	TRAP
FFFC	FFFD	NMI
FFFA	FFFB	Software Interrupt (SWI)
FFFB	FFF9	$\overline{IRQ_1}$ (or \overline{IS})
FFF6	FFF7	ICF (Timer Input Capture)
FFF4	FFF5	OCF (Timer Output Compare)
FFF2	FFF3	TOF (Timer Overflow)
FFF0	FFF1	SCI (IRDRF + ORFE + TDRE)

Highest Priority

Lowest Priority

At the end of the cycle, the CPU generates 16 bit vectoring addresses indicating memory addresses \$FFF8 and \$FFF9, and loads the contents to the Program Counter, then branch to an interrupt service routine.

The Internal Interrupt will generate signal ($\overline{IRQ_2}$) which is quite the same as $\overline{IRQ_1}$ except that it will use the vector address \$FFF0 to \$FFF7.

When $\overline{IRQ_1}$ and $\overline{IRQ_2}$ are generated at the same time, the former precedes the latter. Interrupt Mask Bit in the condition code register, if being set, will keep the both interrupts off.

On occurrence of Address error or Op-code error, TRAP interrupt is invoked. This interrupt has priority next to \overline{RES} . Regardless of the interrupt Mask Bit condition, the CPU will start an interrupt sequence. The vector for this interrupt will be \$FFEE, \$FFEF.

• **Read/Write (R/W)**

This TTL compatible output signals peripheral and memory devices whether CPU is in Read ("High"), or in Write ("Low"). The normal stand-by state is Read ("High"). Its output will drive one TTL load and 90pF capacitance.

• **Address Strobe (AS)**

In the multiplexed mode, address strobe signal appears at this pin. It is used to latch the lower 8 bits addresses multiplexed with data at Do/A0 ~ D7/A7. The 8-bit latch is controlled by address strobe as shown in Figure 15. Thereby, Do/A0 ~ D7/A7 can become data bus during E pulse. The timing chart of this signal is shown in Figure 1.

Address Strobe (AS) is sent out even if the internal address is accessed.

■ **PORTS**

There are two I/O ports on HD6303R MPU (one 8-bit ports and one 5-bit port). Each port has an independent write-only data direction register to program individual I/O pins for input or output.*

When the bit of associated Data Direction Register is "1", I/O pin is programmed for output, if "0", then programmed for



an input.

There are two ports: Port 1, Port 2. Addresses of each port and associated Data Direction Register are shown in Table 2.

- Only one exception is bit 1 of Port 2 which becomes either a data input or a timer output. It cannot be used as an output port.

Table 2 Port and Data Direction Register Addresses

Ports	Port Address	Data Direction Register Address
I/O Port 1	\$0002	\$0000
I/O Port 2	\$0003	\$0001

• I/O Port 1

This is an 8-bit port, each bit being defined individually as input or outputs by associated Data Direction Register. The 8-bit output buffers have three-state capability, maintaining in high impedance state when they are used for input. In order to be read accurately, the voltage on the input lines must be more than 2.0V for logic "1" and less than 0.8V for logic "0".

These are TTL compatible. After the MPU has been reset, all I/O lines are configured as inputs in Multiplexed mode. In Non Multiplexed mode, Port 1 will be output line for lower order address lines ($A_0 \sim A_7$), which can drive one TTL load and 30 pF capacitance.

• I/O Port 2

This port has five lines, whose I/O direction depends on its data direction register. The 5-bit output buffers have three-state capability, going high impedance state when used as inputs. In order to be read accurately, the voltage on the input lines must be more than 2.0V for logic "1" and less than 0.8V for logic "0". After the MPU has been reset, I/O lines are configured as inputs. These pins on Port 2 ($P_{20} \sim P_{22}$ of the chip) are used to program the mode of operation during reset. The values of these three pins during reset are latched into the upper 3 bits (bit 7, 6 and 5) of Port 2 Data Register which is explained in the MODE SELECTION section.

In all modes, Port 2 can be configured as I/O lines. This port also provides access to the Serial I/O and the Timer. However, note that bit 1 (P_{21}) is the only pin restricted to data input or Timer output.

■ BUS

• $D_0/A_0 \sim D_7/A_7$

This TTL compatible three-state buffer can drive one TTL load and 90 pF capacitance.

Non Multiplexed Mode

In this mode, these pins become only data bus ($D_0 \sim D_7$).

Multiplexed Mode

These pins becomes both the data bus ($D_0 \sim D_7$) and lower bits of the address bus ($A_0 \sim A_7$). An address strobe output is "High" when the address is on the pins.

• $A_8 \sim A_{15}$

Each line is TTL compatible and can drive one TTL load and 90 pF capacitance. After reset, these pins become output for upper order address lines ($A_8 \sim A_{15}$).

■ MODE SELECTION

The operation mode after the reset must be determined by the user wiring the P_{20} , P_{21} , and P_{22} externally. These three pins are lower order bits; I/O 0, I/O 1, I/O 2 of Port 2. They are latched into the control bits PC0, PC1, PC2 of I/O Port 2 register when RES goes "High". I/O Port 2 Register is shown below.

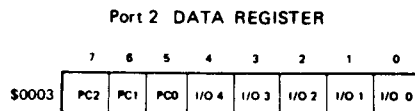

An example of external hardware used for Mode Selection is shown in Figure 11. The HD14053B is used to separate the peripheral device from the MPU during reset. It is necessary if the data may conflict between peripheral device and Mode generation circuit.

No mode can be changed through software because the bits 5, 6, and 7 of Port 2 Data Register are read-only. The mode selection of the HD6303R is shown in Table 3.

The HD6303R operates in two basic modes: (1) Multiplexed Mode, (2) Non Multiplexed Mode.

• Multiplexed Mode

The data bus and the lower order address bus are multiplexed in the $D_0/A_0 \sim D_7/A_7$ and can be separated by the Address Strobe.

Port 2 is configured for 5 parallel I/O or Serial I/O, or Timer, or any combination thereof. Port 1 is configured for 8 parallel I/O.

• Non Multiplexed Mode

In this mode, the HD6303R can directly address HMCS6800 peripherals with no address latch. $D_0/A_0 \sim D_7/A_7$ become a data bus and Port 1 becomes $A_0 \sim A_7$ address bus.

In this mode, the HD6303R is expandable up to 65k bytes with no address latch.

• Lower Order Address Bus Latch

Because the data bus is multiplexed with the lower order address bus in $D_0/A_0 \sim D_7/A_7$ in the multiplexed mode, address bits must be latched. It requires the 74LS373 Transparent octal D-type to latch the LSB. Latch connection of the HD6303R is shown in Figure 15.

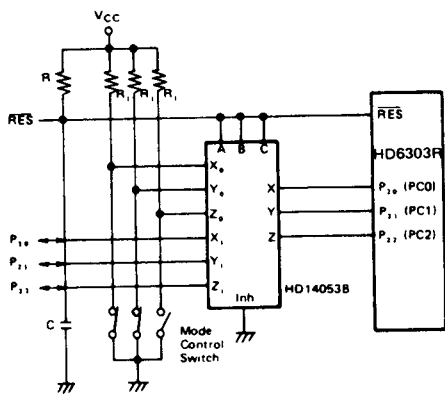

Note 1) Figure of Multiplexed Mode
 2) RC ~ Reset Constant
 3) R₁ = 10kΩ

Figure 11 Recommended Circuit for Mode Selection

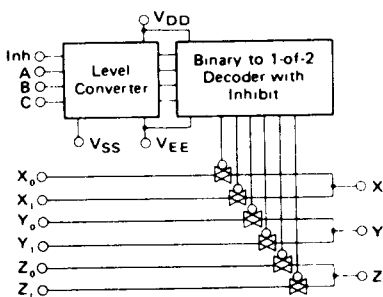

Truth Table

Control Input				On Switch
Inhibit	Select			
	C	B	A	HD14053B
0	0	0	0	Z ₀ , Y ₀ , X ₀
0	0	0	1	Z ₀ , Y ₀ , X ₁
0	0	1	0	Z ₀ , Y ₁ , X ₀
0	0	1	1	Z ₀ , Y ₁ , X ₁
0	1	0	0	Z ₁ , Y ₀ , X ₀
0	1	0	1	Z ₁ , Y ₀ , X ₁
0	1	1	0	Z ₁ , Y ₁ , X ₀
0	1	1	1	Z ₁ , Y ₁ , X ₁
1	X	X	X	

Figure 12 HD14053B Multiplexers/De-Multiplexers

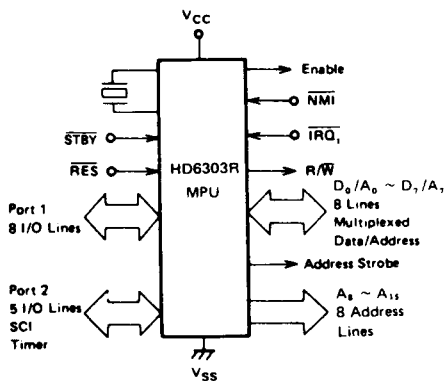

Figure 13 HD6303R MPU Multiplexed Mode

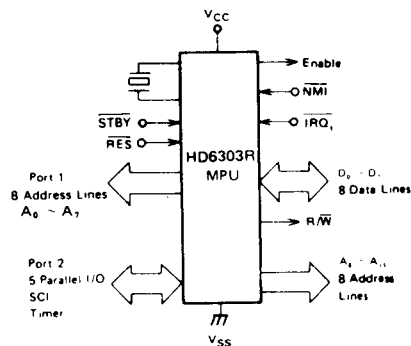

Figure 14 HD6303R MPU Non Multiplexed Mode



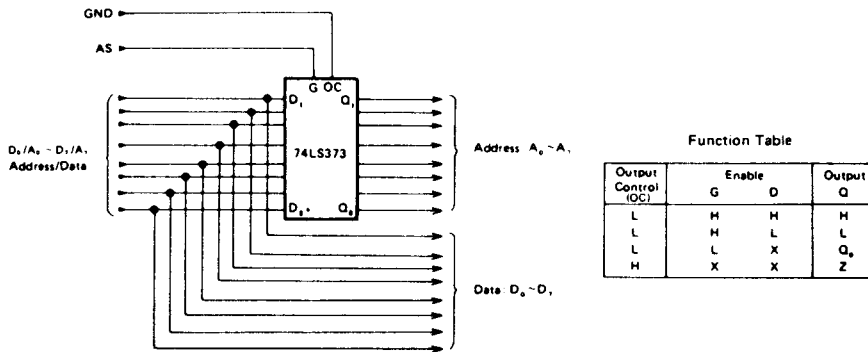

Figure 15 Latch Connection

Table 3 Mode Selection

Operating Mode	P ₂₀	P ₂₁	P ₂₂
Multiplexed Mode	L	H	L
	L	L	H
Non Multiplexed Mode	H	L	L

L: logic "0"
H: logic "1"

■ MEMORY MAP

The MPU can provide up to 65k byte address space. Figure 16 shows a memory map for each operating mode. The first 32 locations of each map are for the CPU's internal register only, as shown in Table 4.

Table 4 Internal Register Area

Register	Address
Port 1 Data Direction Register**	00*
Port 2 Data Direction Register**	01
Port 1 Data Register	02*
Port 2 Data Register	03
Timer Control and Status Register	08
Counter (High Byte)	09
Counter (Low Byte)	0A
Output Compare Register (High Byte)	0B
Output Compare Register (Low Byte)	0C
Input Capture Register (High Byte)	0D
Input Capture Register (Low Byte)	0E
Rate and Mode Control Register	10
Transmit/Receive Control and Status Register	11
Receive Data Register	12
Transmit Data Register	13
RAM Control Register	14
Reserved	15-1F

* External address in Non Multiplexed Mode
** 1 = Output, 0 = Input

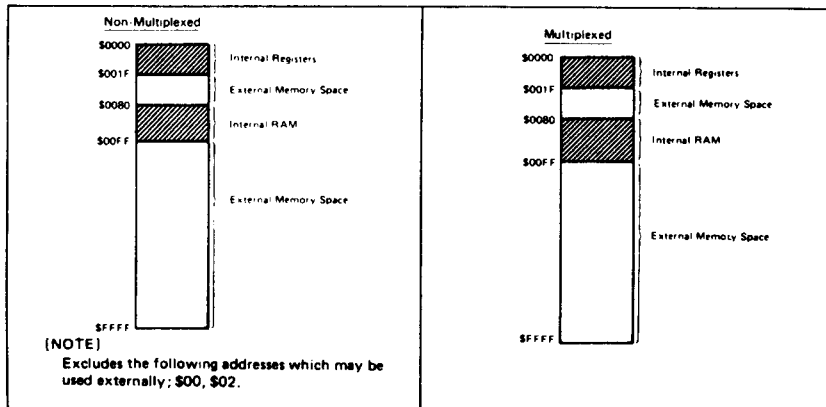

Figure 16 HD6303R Memory Maps



PROGRAMMABLE TIMER

The HD6303R contains 16-bit programmable timer which may measure input waveform. In addition to that it can generate an output waveform by itself. For both input and output waveform, the pulse width may vary from a few microseconds to several seconds.

The timer hardware consists of

- an 8-bit control and status register
- a 16-bit free running counter
- a 16-bit output compare register
- a 16-bit input capture register

A block diagram of the timer is shown in Figure 17.

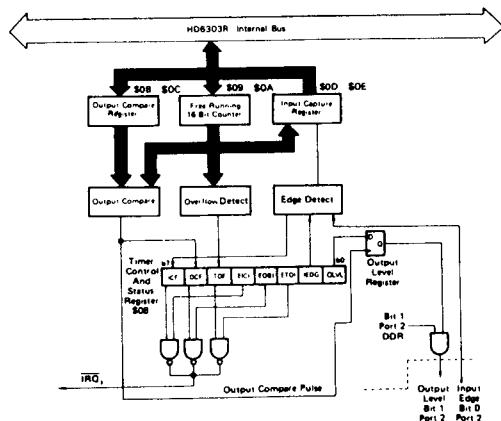

Figure 17 Programmable Timer Block Diagram

Free Running Counter (\$0009: \$000A)

The key element in the programmable timer is a 16-bit free running counter, that is driven by an E (Enable) clock to increment its values. The counter value will be read out by the CPU software at any time with no effects on the counter. Reset will clear the counter.

When the MSB of this counter is read, the LSB is stored in temporary latch. The data is fetched from this latch by the subsequent read of LSB. Thus consistent double byte data can be read from the counter.

When the CPU writes arbitrary data to the MSB (\$09), the value of \$FFF8 is being pre-set to the counter (\$09, \$0A) regardless of the write data value. Then the CPU writes arbitrary data to the LSB (\$0A), the data is set to the "Low" byte of the counter, at the same time, the data preceedingly written in the MSB (\$09) is set to "High" byte of the counter.

When the data is written to this counter, a double byte store instruction (ex. STD) must be used. If only the MSB of counter is written, the counter is set to \$FFF8.

The counter value written to the counter using the double byte store instruction is shown in Figure 18.

To write to the counter can disturb serial operations, so it should be inhibited during using the SCI. If external clock mode is used for SCI, this will not disturb serial operations.

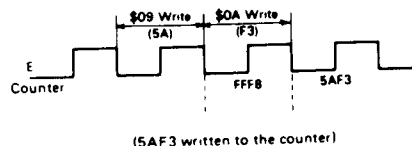

Figure 18 Counter Write Timing

Output Compare Register (\$000B: \$000C)

This is a 16-bit read/write register which is used to control an output waveform. The contents of this register are constantly being compared with current value of the free running counter.

When the contents match with the value of the free running counter, a flag (OCF) in the timer control/status register (TCSR) is set and the current value of an output level Bit (OLVL) in the TCSR is transferred to Port 2 bit 1. When bit 1 of the Port 2 data direction register is "1" (output), the OLVL value will appear on the bit 1 of Port 2. Then, the value of Output Compare Register and Output level bit may be changed for the next compare.

The output compare register is set to \$FFFF during reset.

The compare function is inhibited at the cycle of writing to the high byte of the output compare register and at the cycle just after that to ensure valid compare. It is also inhibited in same manner at writing to the free running counter.

In order to write a data to Output Compare Register, a double byte store instruction (ex. STD) must be used.

Input Capture Register (\$000D: \$000E)

The input capture register is a 16-bit read-only register used to hold the current value of free running counter captured when the proper transition of an external input signal occurs.

The input transition change required to trigger the counter transfer is controlled by the input edge bit (IEDG).

To allow the external input signal to go in the edge detect unit, the bit of the Data Direction Register corresponding to bit 0 of Port 2 must have been cleared (to zero).

To insure input capture in all cases, the width of an input pulse requires at least 2 Enable cycles.

Timer Control/Status Register (TCSR) (\$0008)

This is an 8-bit register. All 8-bits are readable and the lower 5 bits may be written. The upper 3 bits are read-only, indicating the timer status information as is shown below.

- (1) A proper transition has been detected on the input pin (ICF).
- (2) A match has been found between the value in the free running counter and the output compare register (OCF).
- (3) When counting up to \$0000 (TOF).

Each flag has an individual enable bit in TCSR which determines whether or not an interrupt request may occur (IRQ₂). If the 1-bit in Condition Code Register has been cleared, a prior vectored address occurs corresponding to each flag. A description of each bit is as follows.

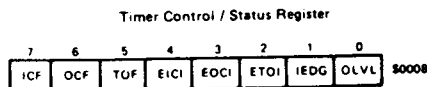

Bit 0 OLVL (Output Level): When a match is found in the value between the counter and the output com-

pare register, this bit is transferred to the Port 2 bit 1. If the DDR corresponding to Port 2 bit 1 is set "1", the value will appear on the output pin of Port 2 bit 1.

- Bit 1 IEDG (Input Edge):** This bit control which transition of an input of Port 2 bit 0 will trigger the data transfer from the counter to the input capture register. The DDR corresponding to Port 2 bit 0 must be clear in advance of using this function. When IEDG = 0, trigger takes place on a negative edge ("High"-to-"Low" transition). When IEDG = 1, trigger takes place on a positive edge ("Low"-to-"High" transition).
- Bit 2 ETOI (Enable Timer Overflow Interrupt):** When set, this bit enables TOF interrupt to generate the interrupt request (IRQ_2). When cleared, the interrupt is inhibited.
- Bit 3 EOCI (Enable Output Compare Interrupt):** When set, this bit enables OCF interrupt to generate the interrupt request (IRQ_2). When cleared, the interrupt is inhibited.
- Bit 4 EICI (Enable Input Capture Interrupt):** When set, this bit enables ICF interrupt to generate the interrupt request (IRQ_2). When cleared, the interrupt is inhibited.
- Bit 5 TOF (Timer Over Flow Flag):** This read-only bit is set at the transition of \$FFFF to \$0000 of the counter. It is cleared by CPU read of TCSR (with TOF set) followed by a CPU read of the counter (\$0009).
- Bit 6 OCF (Output Compare Flag):** This read-only bit is set when a match is found in the value between the output compare register and the counter. It is cleared by a read of TCSR (with OCF set) followed by a CPU write to the output compare register (\$000B or \$000C).
- Bit 7 ICF (Input Capture Flag):** The read-only bit is set by a proper transition on the input, and is cleared by a read of TCSR (with ICF set) followed by a CPU read of Input Capture Register (\$000D).

Reset will clear each bit of Timer Control and Status Register.

■ SERIAL COMMUNICATION INTERFACE

The **HD6303R** contains a full-duplex asynchronous Serial Communication Interface (SCI). SCI may select the several kinds of the data rate. It consists of a transmitter and a receiver which operate independently but with the same data format and the same data rate. Both of transmitter and receiver communicate with the CPU via the data bus and with the outside world through Port 2 bit 2, 3 and 4. Description of hardware, software and register is as follows.

● Wake-Up Feature

In typical multiprocessor applications the software protocol will usually have the designated address at the initial byte of the message. The purpose of Wake-Up feature is to have the non-selected MPU neglect the remainder of the message. Thus the non-selected MPU can inhibit the all further interrupt process until the next message begins.

Wake-Up feature is re-enabled by a ten consecutive "1"s which indicates an idle transmit line. Therefore software protocol must put an idle period between the messages and must prevent it within the message.

With this hardware feature, the non-selected MPU is re-enabled (or "waked-up") by the next message.

● Programmable Options

The HD6303R has the following programmable features.

- data format; standard mark/space (NRZ)
- clock source; external or internal
- baud rate; one of 4 rates per given E clock frequency or 1/8 of external clock
- wake-up feature; enabled or disabled
- interrupt requests; enabled or masked individually for transmitter and receiver
- clock output; internal clock enabled or disabled to Port 2 bit 2
- Port 2 (bits 3, 4); dedicated or not dedicated to serial I/O individually

● Serial Communication Hardware

The serial communications hardware is controlled by 4 registers as shown in Figure 19. The registers include:

- an 8-bit control/status register
- a 4-bit rate/mode control register (write-only)
- an 8-bit read-only receive data register
- an 8-bit write-only transmit data register

Besides these 4 registers, Serial I/O utilizes Port 2 bit 3 (input) and bit 4 (output). Port 2 bit 2 can be used when an option is selected for the internal-clock-out or the external-clock-in.

● Transmit/Receive Control Status Register (TRCSR)

TRCS Register consists of 8 bits which all may be read while only bits 0 to 4 may be written. The register is initialized to \$20 on RES. The bits of the TRCS Register are explained below.

Transmit / Receive Control Status Register

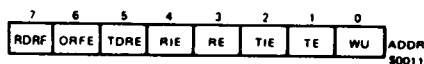

Bit 0 WU (Wake Up); Set by software and cleared by hardware on receipt of ten consecutive "1"s. While this bit is "1", RDRF and ORFE flags are not set even if data are received or errors are detected. Therefore received data are ignored. It should be noted that RE flag must have already been set in advance of WU flag's set.

Bit 1 TE (Transmit Enable); This bit enables transmitter. When this bit is set, bit 4 of Port 2 DDR is also forced to be set. It remains set even if TE is cleared. Preamble of ten consecutive "1"s is transmitted just after this bit is set, and then transmitter becomes ready to send data. If this bit is cleared, the transmitter is disabled and serial I/O affects nothing on Port 2 bit 4.

Bit 2 TIE (Transmit Interrupt Enable); When this bit is set, TDRE (bit 5) causes an IRQ_2 interrupt. When cleared, TDRE interrupt is masked.

Bit 3 RE (Receive Enable); When set, Port 2 bit 3 can be used as an input of receive regardless of DDR value for this bit. When cleared, the receiver is disabled.

Bit 4 RIE (Receive Interrupt Enable); When this bit is set, RDRF (bit 7) or ORFE (bit 6) cause an IRQ_2 interrupt. When cleared, this interrupt is masked.

Bit 5 TDRE (Transmit Data Register Empty); When the data is transferred from the Transmit Data Register to Output Shift Register, this bit is set by hardware. The bit is cleared by reading the status register followed by writing the next new data into the Transmit Data Register. TDRE is initialized to 1 by RES.

Bit 6 ORFE (Over Run Framing Error); When overrun or framing error occurs (receive only), this bit is set by hardware. Over Run Error occurs if the attempt is made to transfer the new byte to the receive data register while the RDRF is "1". Framing Error occurs when the bit counter is not synchronized with the boundary of the byte in the re-

ceiving bit stream. When Framing Error is detected, RDRF is not set. Therefore Framing Error can be distinguished from Overrun Error. That is, if ORFE is "1" and RDRF is "1", Overrun Error is detected. Otherwise Framing Error occurs. The bit is cleared by reading the status register followed by reading the receive data register, or by RES.

Bit 7 RDRF (Receive Data Register Full); This bit is set by hardware when the data is transferred from the receive shift register to the receive data register. It is cleared by reading the status register followed by reading the receive data register, or by RES.

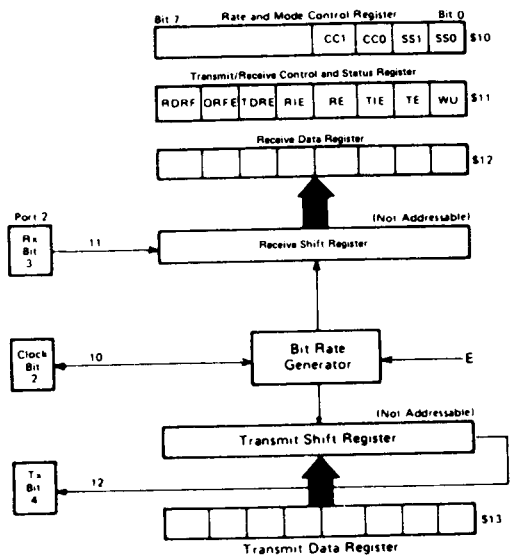

Figure 19 Serial I/O Register

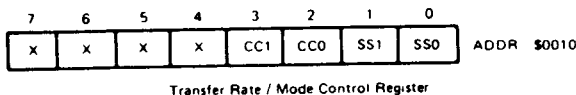

Table 5 SCI Bit Times and Transfer Rates

SS1	SS0	XTAL	2.4576 MHz	4.0 MHz	4.9152MHz
		E	614.4 kHz	1.0 MHz	1.2288MHz
0	0	E ÷ 16	26 μs/38,400 Baud	16 μs/62,500 Baud	13 μs/76,800Baud
0	1	E ÷ 128	208μs/4,800 Baud	128 μs/7812.5 Baud	104 2μs/ 9,600Baud
1	0	E ÷ 1024	1.67ms/600 Baud	1.024ms/976.6 Baud	833 3μs/ 1,200Baud
1	1	E ÷ 4096	6.67ms/150 Baud	4.096ms/244.1 Baud	3.333ms/ 300Baud



Table 6 SCI Format and Clock Source Control

CC1: CC0	Format	Clock Source	Port 2 Bit 2	Port 2 Bit 3	Port 2 Bit 4
0 0	—	—	—	—	—
0 1	NRZ	Internal	Not Used***	**	**
1 0	NRZ	Internal	Output*	**	**
1 1	NRZ	External	Input	**	**

- * Clock output is available regardless of values for bits RE and TE.
- ** Bit 3 is used for serial input if RE = "1" in TRCS.
Bit 4 is used for serial output if TE = "1" in TRCS.
- *** This pin can be used as I/O port.

• Transfer Rate/Mode Control Register (RMCR)

The register controls the following serial I/O functions:

- Bauds rate
- data format
- clock source
- Port 2 bit 2 feature

It is 4-bit write-only register, cleared by RES. The 4 bits are considered as a pair of 2-bit fields. The lower 2 bits control the bit rate of internal clock while the upper 2 bits control the format and the clock select logic.

Bit 0 SS0 }
Bit 1 SS1 } Speed Select

These bits select the Baud rate for the internal clock. The rates selectable are function of E clock frequency of the CPU. Table 5 lists the available Baud Rates.

Bit 2 CC0 }
Bit 3 CC1 } Clock Control/Format Select

They control the data format and the clock select logic. Table 6 defines the bit field.

• Internally Generated Clock

If the user wish to use externally an internal clock of the serial I/O, the following requirements should be noted.

- CC1, CC0 must be set to "10".
- The maximum clock rate must be E/16.
- The clock rate is equal to the bit rate.
- The values of RE and TE have no effect.

• Externally Generated Clock

If the user wish to supply an external clock to the Serial I/O, the following requirements should be noted.

- The CC1, CC0 must be set to "11" (See Table 6).
- The external clock must be set to 8 times of the desired baud rate.
- The maximum external clock frequency is E/2 clock.

• Serial Operations

The serial I/O hardware must be initialized by the software before operation. The sequence will be normally as follows.

- Writing the desired operation control bits of the Rate and Mode Control Register.
- Writing the desired operation control bits of the TRCS register.

If Port 2 bit 3, 4 are used for serial I/O, TE, RE bits may be kept set. When TE, RE bit are cleared during SCI operation, and subsequently set again, it should be noted that TE, RE must be kept "0" for at least one bit time of the current baud rate. If TE, RE are set again within one bit time, there may be the case where the initializing of internal function for transmitter and receiver does not take place correctly.

• Transmit Operation

Data transmission is enabled by the TE bit in the TRCS

register. When set, the output of the transmit shift register is connected with Port 2 bit 4 which is unconditionally configured as an output.

After RES, the user should initialize both the RMC register and the TRCS register for desired operation. Setting the TE bit causes a transmission of ten-bit preamble of "1"s. Following the preamble, internal synchronization is established and the transmitter is ready to operate. Then either of the following states exists.

- (1) If the transmit data register is empty (TDRE = 1), the consecutive "1"s are transmitted indicating an idle states.
- (2) If the data has been loaded into the Transmit Data Register (TDRE = 0), it is transferred to the output shift register and data transmission begins.

During the data transfer, the start bit ("0") is first transferred. Next the 8-bit data (beginning at bit 0) and finally the stop bit ("1"). When the contents of the Transmit Data Register is transferred to the output shift register, the hardware sets the TDRE flag bit: If the CPU fails to respond to the flag within the proper time, TDRE is kept set and then a continuous string of 1's is sent until the data is supplied to the data register.

• Receive Operation

The receive operation is enabled by the RE bit. The serial input is connected with Port 2 bit 3. The receiver operation is determined by the contents of the TRCS and RMC register. The received bit stream is synchronized by the first "0" (start bit). During 10-bit time, the data is strobed approximately at the center of each bit. If the tenth bit is not "1" (stop bit), the system assumes a framing error and the ORFE is set.

If the tenth bit is "1", the data is transferred to the receive data register, and the RDRF flag is set. If the tenth bit of the next data is received and still RDRF is preserved set, then ORFE is set indicating that an overrun error has occurred.

After the CPU read of the status register as a response to RDRF flag or ORFE flag, followed by the CPU read of the receive data register, RDRF or ORFE will be cleared.

■ RAM CONTROL REGISTER

The register assigned to the address \$0014 gives a status information about standby RAM.

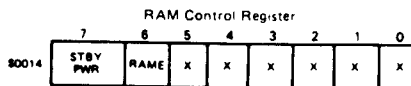

- Bit 0 Not used.
- Bit 1 Not used.
- Bit 2 Not used.



Bit 3 Not used.

Bit 4 Not used.

Bit 5 Not used.

Bit 6 RAM Enable (RAME).

Using this control bit, the user can disable the RAM. RAM Enable bit is set on the positive edge of RES and RAM is enabled. The program can write "1" or "0". If RAME is cleared, the RAM address becomes external address and the CPU may read the data from the outside memory.

Bit 7 Standby Power Bit (STBY PWR)

This bit can be read or written by the user program. It is cleared when the V_{CC} voltage is removed. Normally this bit is set by the program before going into stand-by mode. When the CPU recovers from stand-by mode, this bit should be checked. If it is "1", the data of the RAM is retained during stand-by and it is valid.

■ GENERAL DESCRIPTION OF INSTRUCTION SET

The HD6303R has an upward object code compatible with the HD6801 to utilize all instruction sets of the HMCS6800. The execution time of the key instruction is reduced to increase the system through-put. In addition, the bit operation instruction, the exchange instruction between the index and the accumulator, the sleep instruction are added. This section describes:

- CPU programming model (See Fig. 20)
- Addressing modes
- Accumulator and memory manipulation instructions (See Table 7)
- New instructions
- Index register and stack manipulation instructions (See Table 8)
- Jump and branch instructions (See Table 9)
- Condition code register manipulation instructions (See Table 10)
- Op-code map (See Table 11)
- Cycle-by-cycle operation (See Table 12)

● CPU Programming Model

The programming model for the HD6303R is shown in Figure 20. The double accumulator is physically the same as the accumulator A concatenated with the accumulator B, so that the contents of A and B is changed with executing operation of an accumulator D.

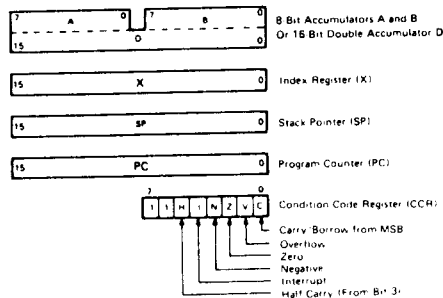

Figure 20 CPU Programming Model

● CPU Addressing Modes

The HD6303R has seven address modes which depend on both of the instruction type and the code. The address mode for

every instruction is shown along with execution time given in terms of machine cycles (Table 7 to 11). When the clock frequency is 4 MHz, the machine cycle will be microseconds.

Accumulator (ACCX) Addressing

Only the accumulator (A or B) is addressed. Either accumulator A or B is specified by one-byte instructions.

Immediate Addressing

In this mode, the operand is stored in the second byte of the instruction except that the operand in LDS and LDX, etc are stored in the second and the third byte. These are two or three-byte instructions.

Direct Addressing

In this mode, the second byte of instruction indicates the address where the operand is stored. Direct addressing allows the user to directly address the lowest 256 bytes in the machine; locations zero through 255. Improved execution times are achieved by storing data in these locations. For system configuration, it is recommended that these locations should be RAM and be utilized preferably for user's data realm. These are two-byte instructions except the AIM, OIM, EIM and TIM which have three-byte.

Extended Addressing

In this mode, the second byte indicates the upper 8 bit addresses where the operand is stored, while the third byte indicates the lower 8 bits. This is an absolute address in memory. These are three-byte instructions.

Implied Addressing

In this mode, the contents of the second byte is added to the lower 8 bits in the Index Register. For each of AIM, OIM, EIM and TIM instructions, the contents of the third byte are added to the lower 8 bits in the Index Register. In addition, the resulting "carry" is added to the upper 8 bits in the Index Register. The result is used for addressing memory. Because the modified address is held in the Temporary Address Register, there is no change to the Index Register. These are two-byte instructions but AIM, OIM, EIM, TIM have three-byte.

Implied Addressing

In this mode, the instruction itself gives the address; stack pointer, index register, etc. These are 1-byte instructions.

Relative Addressing

In this mode, the contents of the second byte is added to the lower 8 bits in the program counter. The resulting carry or borrow is added to the upper 8 bits. This helps the user to address the data within a range of -126 to +129 bytes of the current execution instruction. These are two-byte instructions.

2

Table 7 Accumulator, Memory Manipulation Instructions

Operations	Mnemonic	Addressing Modes												Boolean/ Arithmetic Operation	Condition Code Register								
		IMMED		DIRECT		INDEX		EXTEND		IMPLIED		5	4		3	2	1	0					
		OP	~ #	OP	~ #	OP	~ #	OP	~ #	OP	~ #												
Add	ADDA	88	2	2	9B	3	2	AB	4	2	BB	4	3			A + M - A	I	•	I	I	I	I	
	ADDB	CB	2	2	DB	3	2	EB	4	2	FB	4	3			B + M - B	I	•	I	I	I	I	
Add Double	ADDD	C3	3	3	D3	4	2	E3	5	2	F3	5	3			A + B + M · M + 1 → A · B	•	•	I	I	I	I	
Add Accumulators	ABA													1B	1	1	A + B - A	I	•	I	I	I	I
Add With Carry	ADCA	89	2	2	99	3	2	A9	4	2	B9	4	3			A + M + C → A	I	•	I	I	I	I	
	ADCB	C9	2	2	D9	3	2	E9	4	2	F9	4	3			B + M + C → B	I	•	I	I	I	I	
AND	ANDA	84	2	2	94	3	2	A4	4	2	B4	4	3			A · M → A	•	•	I	I	R	•	
	ANDB	C4	2	2	D4	3	2	E4	4	2	F4	4	3			B · M → B	•	•	I	I	R	•	
Bit Test	BIT A	85	2	2	95	3	2	A5	4	2	B5	4	3			A · M	•	•	I	I	R	•	
	BIT B	C5	2	2	D5	3	2	E5	4	2	F5	4	3			B · M	•	•	I	I	R	•	
Clear	CLR							6F	5	2	7F	5	3			00 - M	•	•	I	R	S	R	
	CLRA													4F	1	1	00 - A	•	•	I	R	S	R
	CLRB													5F	1	1	00 - B	•	•	I	R	S	R
Compare	CMPA	81	2	2	91	3	2	A1	4	2	B1	4	3			A - M	•	•	I	I	I	I	
	CMPB	C1	2	2	D1	3	2	E1	4	2	F1	4	3			B - M	•	•	I	I	I	I	
Compare Accumulators	CBA													11	1	1	A - B	•	•	I	I	I	I
Complement, 1's	COM							63	6	2	73	6	3			M - M	•	•	I	I	R	S	
	COMA													43	1	1	A - A	•	•	I	I	R	S
	COMB													53	1	1	B - B	•	•	I	I	R	S
Complement, 2's (Negate)	NEG							60	6	2	70	6	3			00 - M - M	•	•	I	I	①	②	
	NEGA													40	1	1	00 - A - A	•	•	I	I	①	②
	NEGB													50	1	1	00 - B - B	•	•	I	I	①	②
Decimal Adjust, A	DAA													19	2	1	Converts binary add of BCD characters into BCD format	•	•	I	I	I	③
Decrement	DEC							6A	6	2	7A	6	3			M - 1 - M	•	•	I	I	④	•	
	DECA													4A	1	1	A - 1 - A	•	•	I	I	④	•
	DECB													5A	1	1	B - 1 - B	•	•	I	I	④	•
Exclusive OR	EDRA	88	2	2	98	3	2	A8	4	2	B8	4	3			A ⊕ M → A	•	•	I	I	R	•	
	EORB	C8	2	2	D8	3	2	E8	4	2	F8	4	3			B ⊕ M → B	•	•	I	I	R	•	
Increment	INC							6C	6	2	7C	6	3			M + 1 - M	•	•	I	I	⑤	•	
	INCA													4C	1	1	A + 1 - A	•	•	I	I	⑤	•
	INCB													5C	1	1	B + 1 - B	•	•	I	I	⑤	•
Load Accumulator	LDAA	86	2	2	96	3	2	A6	4	2	B6	4	3			M - A	•	•	I	I	R	•	
	LDAB	C6	2	2	D6	3	2	E6	4	2	F6	4	3			M - B	•	•	I	I	R	•	
Load Double Accumulator	LDD	CC	3	3	DC	4	2	EC	5	2	FC	5	3			M + 1 - B, M - A	•	•	I	I	R	•	
Multiply Unsigned	MUL													3D	7	1	A × B - A · B	•	•	•	•	•	⑥
OR, Inclusive	ORAA	8A	2	2	9A	3	2	AA	4	2	BA	4	3			A + M → A	•	•	I	I	R	•	
	ORAB	CA	2	2	DA	3	2	EA	4	2	FA	4	3			B + M → B	•	•	I	I	R	•	
Push Data	PSHA													36	4	1	A - M _{sp} , SP - 1 → SP	•	•	•	•	•	•
	PSHB													37	4	1	B - M _{sp} , SP - 1 → SP	•	•	•	•	•	•
Pull Data	PULA													32	3	1	SP + 1 → SP, M _{sp} → A	•	•	•	•	•	•
	PULB													33	3	1	SP + 1 → SP, M _{sp} → B	•	•	•	•	•	•
Rotate Left	ROL							69	6	2	79	6	3				•	•	I	I	⑦	I	
	ROLA													49	1	1		M	•	•	I	⑦	I
	ROLB													59	1	1		B	•	•	I	⑦	I
Rotate Right	ROR							66	6	2	76	6	3				•	•	I	I	⑧	I	
	RORA													46	1	1		M	•	•	I	⑧	I
	RORB													56	1	1		B	•	•	I	⑧	I

Note) Condition Code Register will be explained in Note of Table 10.

(to be continued)



Table 7 Accumulator, Memory Manipulation Instructions

Operations	Mnemonic	Addressing Modes										Boolean/ Arithmetic Operation	Condition Code Register											
		IMMED		DIRECT		INDEX		EXTEND		IMPLIED			H	I	N	Z	V	C						
		OP	#	OP	#	OP	#	OP	#	OP	#													
Shift Left Arithmetic	ASL							68	6	2	78	6	3	M		•	•	•	•	•	•			
	ASLA													48	1	1	A		•	•	•	•	•	•
	ASLB														58	1	1	B		•	•	•	•	•
Double Shift Left, Arithmetic	ASLD													05	1	1	C		•	•	•	•	•	•
Shift Right Arithmetic	ASR							67	6	2	77	6	3	M		•	•	•	•	•	•			
	ASRA													47	1	1	A		•	•	•	•	•	•
	ASRB														57	1	1	B		•	•	•	•	•
Shift Right Logical	LSR							64	6	2	74	6	3	M		•	•	•	•	•	•			
	LSRA													44	1	1	A		•	•	•	•	•	•
	LSRB														54	1	1	B		•	•	•	•	•
Double Shift Right Logical	LSRD													04	1	1	C		•	•	•	•	•	•
Store Accumulator	STAA			97	3	2	A7	4	2	B7	4	3		A → M	•	•	•	•	•	•				
	STAB			D7	3	2	E7	4	2	F7	4	3		B → M	•	•	•	•	•	•				
Store Double Accumulator	STD			DD	4	2	ED	5	2	FD	5	3		A → M B → M + 1	•	•	•	•	•	•				
Subtract	SUBA	80	2	2	90	3	2	A0	4	2	B0	4	3		A - M → A	•	•	•	•	•	•			
	SUBB	C0	2	2	D0	3	2	E0	4	2	F0	4	3		B - M → B	•	•	•	•	•	•			
Double Subtract	SUBD	83	3	3	93	4	2	A3	5	2	B3	5	3		A : B - M : M + 1 → A : B	•	•	•	•	•	•			
Subtract Accumulators	SBA												10	1	1		A - B → A	•	•	•	•	•	•	
Subtract With Carry	SBCA	82	2	2	92	3	2	A2	4	2	B2	4	3		A - M - C → A	•	•	•	•	•	•			
	SBCB	C2	2	2	D2	3	2	E2	4	2	F2	4	3		B - M - C → B	•	•	•	•	•	•			
Transfer Accumulators	TAB												16	1	1		A → B	•	•	•	•	•	•	
	TBA													17	1	1		B → A	•	•	•	•	•	•
Test Zero or Minus	TST							6D	4	2	7D	4	3		M - 00	•	•	•	•	•	•			
	TSTA													4D	1	1		A - 00	•	•	•	•	•	•
	TSTB														5D	1	1		B - 00	•	•	•	•	•
And Immediate	AIM				71	6	3	61	7	3					M : IMM → M	•	•	•	•	•	•			
OR Immediate	OIM				72	6	3	62	7	3					M + IMM → M	•	•	•	•	•	•			
EOR Immediate	EIM				75	6	3	65	7	3					M ⊕ IMM → M	•	•	•	•	•	•			
Test Immediate	TIM				78	4	3	68	5	3					M : IMM	•	•	•	•	•	•			

Note) Condition Code Register will be explained in Note of Table 10.



• **New Instructions**

In addition to the HD6801 Instruction Set, the HD6303R has the following new instructions:

AIM---(M) · (IMM) → (M)

Evaluates the AND of the immediate data and the memory, places the result in the memory.

OIM---(M) + (IMM) → (M)

Evaluates the OR of the immediate data and the memory, places the result in the memory.

EIM---(M) ⊕ (IMM) → (M)

Evaluates the EOR of the immediate data and the memory, places the result in the memory.

TIM---(M) · (IMM)

Evaluates the AND of the immediate data and the register, changes the flag of associated condition code register

Each instruction has three bytes; the first is op-code, the second is immediate data, the third is address modifier.

XGDX--(ACCD) ↔ (IX)

Exchanges the contents of accumulator and the index register.

SLP---The MPU is brought to the sleep mode. For sleep mode, see the "sleep mode" section.

Table 8 Index Register, Stack Manipulation Instructions

Pointer Operations	Mnemonic	Addressing Modes										Boolean/ Arithmetic Operation	Condition Code Register											
		IMMED		DIRECT		INDEX		EXTEND		IMPLIED			5	4	3	2	1	0						
		OP ~ #	OP ~ #	OP ~ #	OP ~ #	OP ~ #	OP ~ #	OP ~ #	OP ~ #															
Compare Index Reg	CPX	8C	3	3	9C	4	2	AC	5	2	BC	5	3					X - M, M + 1	•	•	1	1	1	1
Decrement Index Reg	DEX													09	1	1		X - 1 → X	•	•	•	1	•	•
Decrement Stack Pntr	DES													34	1	1		SP - 1 → SP	•	•	•	•	•	•
Increment Index Reg	INX													08	1	1		X + 1 → X	•	•	•	1	•	•
Increment Stack Pntr	INS													31	1	1		SP + 1 → SP	•	•	•	•	•	•
Load Index Reg	LDX	CE	3	3	DE	4	2	EE	5	2	FE	5	3					M → X _H , (M + 1) → X _L	•	•	Ⓣ	1	R	•
Load Stack Pntr	LDS	8E	3	3	9E	4	2	AE	5	2	BE	5	3					M → SP _H , (M + 1) → SP _L	•	•	Ⓣ	1	R	•
Store Index Reg	STX				DF	4	2	EF	5	2	FF	5	3					X _H → M, X _L → (M + 1)	•	•	Ⓣ	1	R	•
Store Stack Pntr	STS				9F	4	2	AF	5	2	BF	5	3					SP _H → M, SP _L → (M + 1)	•	•	Ⓣ	1	R	•
Index Reg → Stack Pntr	TXS													35	1	1		X - 1 → SP	•	•	•	•	•	•
Stack Pntr → Index Reg	TSX													30	1	1		SP + 1 → X	•	•	•	•	•	•
Add	ABX													3A	1	1		B + X → X	•	•	•	•	•	•
Push Data	PSHX													3C	5	1		X _L → M _{sp} , SP - 1 → SP	•	•	•	•	•	•
																		X _H → M _{sp} , SP - 1 → SP	•	•	•	•	•	•
Pop Data	PULX													38	4	1		SP + 1 → SP, M _{sp} → X _H	•	•	•	•	•	•
																		SP + 1 → SP, M _{sp} → X _L	•	•	•	•	•	•
Exchange	XGDX													18	2	1		ACCD ↔ IX	•	•	•	•	•	•

Note) Condition Code Register will be explained in Note of Table 10.

Table 9 Jump, Branch Instruction

Operations	Mnemonic	Addressing Modes										Branch Test	Condition Code Register						
		RELATIVE		DIRECT		INDEX		EXTEND		IMPLIED			H	I	N	Z	V	C	
		OP	#	OP	#	OP	#	OP	#	OP	#								
Branch Always	BRA	20	3	2									None	*	*	*	*	*	*
Branch Never	BRN	21	3	2									None	*	*	*	*	*	*
Branch If Carry Clear	BCC	24	3	2									C = 0	*	*	*	*	*	*
Branch If Carry Set	BCS	25	3	2									C = 1	*	*	*	*	*	*
Branch If = Zero	BEQ	27	3	2									Z = 1	*	*	*	*	*	*
Branch If > Zero	BGE	2C	3	2									$N \oplus V = 0$	*	*	*	*	*	*
Branch If > Zero	BGT	2E	3	2									$Z + (N \oplus V) = 0$	*	*	*	*	*	*
Branch If Higher	BHI	22	3	2									C + Z = 0	*	*	*	*	*	*
Branch If < Zero	BLE	2F	3	2									$Z + (N \oplus V) = 1$	*	*	*	*	*	*
Branch If Lower Or Same	BLS	23	3	2									C + Z = 1	*	*	*	*	*	*
Branch If < Zero	BLT	2D	3	2									$N \oplus V = 1$	*	*	*	*	*	*
Branch If Minus	BMI	2B	3	2									N = 1	*	*	*	*	*	*
Branch If Not Equal Zero	BNE	26	3	2									Z = 0	*	*	*	*	*	*
Branch If Overflow Clear	BVC	28	3	2									V = 0	*	*	*	*	*	*
Branch If Overflow Set	BVS	29	3	2									V = 1	*	*	*	*	*	*
Branch If Plus	BPL	2A	3	2									N = 0	*	*	*	*	*	*
Branch To Subroutine	BSR	8D	5	2										*	*	*	*	*	*
Jump	JMP					8E	3	2	7E	3	3			*	*	*	*	*	*
Jump To Subroutine	JSR				9D	5	2	AD	5	2	BD	6	3		*	*	*	*	*
No Operation	NOP												01 1 1	Advances Prog. Cntr. Only	*	*	*	*	*
Return From Interrupt	RTI												3B 10 1		*	*	*	*	*
Return From Subroutine	RTS												39 5 1		*	*	*	*	*
Software Interrupt	SWI												3F 12 1		*	*	*	*	*
Wait for Interrupt*	WAI												3E 9 1		*	*	*	*	*
Sleep	SLP												1A 4 1		*	*	*	*	*

Note) *WAI puts R/W high; Address Bus goes to FFFF; Data Bus goes to the three state.
Condition Code Register will be explained in Note of Table 10.



Table 10 Condition Code Register Manipulation Instructions

Operations	Mnemonic	Addressing Modes			Boolean Operation	Condition Code Register						
		IMPLIED				5	4	3	2	1	0	
		OP	~	#								
Clear Carry	CLC	0C	1	1	0 → C	•	•	•	•	•	•	R
Clear Interrupt Mask	CLI	0E	1	1	0 → I	•	R	•	•	•	•	•
Clear Overflow	CLV	0A	1	1	0 → V	•	•	•	•	•	R	•
Set Carry	SEC	0D	1	1	1 → C	•	•	•	•	•	•	S
Set Interrupt Mask	SEI	0F	1	1	1 → I	•	S	•	•	•	•	•
Set Overflow	SEV	0B	1	1	1 → V	•	•	•	•	•	S	•
Accumulator A → CCR	TAP	06	1	1	A → CCR	⑩						
CCR → Accumulator A	TPA	07	1	1	CCR → A	•	•	•	•	•	•	•

(NOTE 1) Condition Code Register Notes: (Bit set if test is true and cleared otherwise)

- ① (Bit V) Test: Result = 10000000?
- ② (Bit C) Test: Result ≠ 00000000?
- ③ (Bit C) Test: BCD Character of high-order byte greater than 9? (Not cleared if previously set)
- ④ (Bit V) Test: Operand = 10000000 prior to execution?
- ⑤ (Bit V) Test: Operand = 01111111 prior to execution?
- ⑥ (Bit V) Test: Set equal to N=C=1 after the execution of instructions
- ⑦ (Bit N) Test: Result less than zero? (Bit 15=1)
- ⑧ (All Bit) Load Condition Code Register from Stack.
- ⑨ (Bit I) Set when interrupt occurs. If previously set, a Non-Maskable Interrupt is required to exit the wait state.
- ⑩ (All Bit) Set according to the contents of Accumulator A.
- ⑪ (Bit C) Result of Multiplication Bit 7=1 of ACCB?

(NOTE 2) CLI instruction and interrupt.

If interrupt mask-bit is set (I=1) and interrupt is requested ($\overline{IRQ}_1 = "0"$ or $\overline{IRQ}_2 = "0"$), and then CLI instruction is executed, the CPU responds as follows.

- ① The next instruction of CLI is one-machine cycle instruction. Subsequent two instructions are executed before the interrupt is responded. That is, the next and the next of the next instruction are executed.
- ② The next instruction of CLI is two-machine cycle (or more) instruction. Only the next instruction is executed and then the CPU jump to the interrupt routine. Even if TAP instruction is used, instead of CLI, the same thing occurs.

Table 11 OP-Code Map

OP CODE	ACC A		ACC B		IND	EXT DIR	ACCA or SP				ACCB or X								
	HI	LO	0000	0001			0010	0011	0100	0101	0110	0111	1000	1001	1010	1011	1100	1101	1110
0000	0	0	SBA	BRA	TSX	NEG													0
0001	1	1	NOP	CBA	BRN	INS	AIM												1
0010	2	2			BHI	PULA		OIM											2
0011	3	3			BLS	PULB	COM												3
0100	4	4	LSRD		BCC	DES	LSR												4
0101	5	5	ASLD		BCS	TXS	EIM												5
0110	6	6	TAP	TAB	BNE	PSHA	ROR												6
0111	7	7	TPA	TBA	BEQ	PSHB	ASR												7
1000	8	8	INX	XGDX	BVC	PULX	ASL												8
1001	9	9	DEX	DAA	BVS	RTS	ROL												9
1010	A	A	CLV	SLP	BPL	ABX	DEC												A
1011	B	B	SEV	ABA	BMI	RTI	TIM												B
1100	C	C	CLC		BGE	PSHX	INC												C
1101	D	D	SEC		BLT	MUL	TST												D
1110	E	E	CLI		BGT	WAI	JMP												E
1111	F	F	SEI		BLE	SWI	CLR												F

UNDEFINED OP CODE

* Only for instructions of AIM, OIM, EIM, TIM



● **Instruction Execution Cycles**

In the HMCS6800 series, the execution cycle of each instruction is the number of cycles between the start of the current instruction fetch and just before the start of the subsequent instruction fetch.

The HD6303R uses a mechanism of the pipeline control for the instruction fetch and the subsequent instruction fetch is performed during the current instruction being executed.

Therefore, the method to count instruction cycles used in the HMCS6800 series cannot be applied to the instruction cycles such as MULT, PULL, DAA and XGDX in the HD6303R.

Table 12 provides the information about the relationship among each data on the Address Bus, Data Bus, and R/W status in cycle-by-cycle basis during the execution of each instruction.

Table 12 Cycle-by-Cycle Operation

Address Mode & Instructions	Cycles	Cycle #	Address Bus	R/W	Data Bus	
IMMEDIATE						
ADC ADD	2	1	Op Code Address + 1	1	Operand Data	
AND BIT		2	Op Code Address + 2	1	Next Op Code	
CMP EOR						
LDA ORA						
SBC SUB						
ADDD CPX	3	1	Op Code Address + 1	1	Operand Data (MSB)	
LDD LDS		2	Op Code Address + 2	1	Operand Data (LSB)	
LDX SUBD		3	Op Code Address + 3	1	Next Op Code	
DIRECT						
ADC ADD	3	1	Op Code Address + 1	1	Address of Operand (LSB)	
AND BIT		2	Address of Operand	1	Operand Data	
CMP EOR		3	Op Code Address + 2	1	Next Op Code	
LDA ORA	3	1	Op Code Address + 1	1	Destination Address	
SBC SUB		2	Destination Address	0	Accumulator Data	
STA		3	Op Code Address + 2	1	Next Op Code	
ADDD CPX		1	Op Code Address + 1	1	Address of Operand (LSB)	
LDD LDS		2	Address of Operand	1	Operand Data (MSB)	
LDX SUBD	4	3	Address of Operand + 1	1	Operand Data (LSB)	
		4	Op Code Address + 2	1	Next Op Code	
STD STS	4	1	Op Code Address + 1	1	Destination Address (LSB)	
STX		2	Destination Address	0	Register Data (MSB)	
		3	Destination Address + 1	0	Register Data (LSB)	
		4	Op Code Address + 2	1	Next Op Code	
JSR	5	1	Op Code Address + 1	1	Jump Address (LSB)	
		2	FFFF	1	Restart Address (LSB)	
		3	Stack Pointer	0	Return Address (LSB)	
		4	Stack Pointer - 1	0	Return Address (MSB)	
		5	Jump Address	1	First Subroutine Op Code	
TIM	4	1	Op Code Address + 1	1	Immediate Data	
		2	Op Code Address + 2	1	Address of Operand (LSB)	
		3	Address of Operand	1	Operand Data	
		4	Op Code Address + 3	1	Next Op Code	
AIM EIM	6	1	Op Code Address + 1	1	Immediate Data	
OIM		2	Op Code Address + 2	1	Address of Operand (LSB)	
		3	Address of Operand	1	Operand Data	
		4	FFFF	1	Restart Address (LSB)	
		5	Address of Operand	0	New Operand Data	
		6	Op Code Address + 3	1	Next Op Code	

- Continued -



Table 12 Cycle-by-Cycle Operation (Continued)

Address Mode & Instructions	Cycles	Cycle #	Address Bus	R W	Data Bus
INDEXED					
JMP	3	1	Op Code Address + 1	1	Offset
		2	FFFF	1	Restart Address (LSB)
		3	Jump Address	1	First Op Code of Jump Routine
ADC ADD AND BIT CMP EOR LDA ORA SBC SUB TST	4	1	Op Code Address + 1	1	Offset
		2	FFFF	1	Restart Address (LSB)
		3	IX + Offset	1	Operand Data
		4	Op Code Address + 2	1	Next Op Code
STA	4	1	Op Code Address + 1	1	Offset
		2	FFFF	1	Restart Address (LSB)
		3	IX + Offset	0	Accumulator Data
		4	Op Code Address + 2	1	Next Op Code
ADDD CPX LDD LDS LDX SUBD	5	1	Op Code Address + 1	1	Offset
		2	FFFF	1	Restart Address (LSB)
		3	IX + Offset	1	Operand Data (MSB)
		4	IX + Offset + 1	1	Operand Data (LSB)
		5	Op Code Address + 2	1	Next Op Code
STD STS STX	5	1	Op Code Address + 1	1	Offset
		2	FFFF	1	Restart Address (LSB)
		3	IX + Offset	0	Register Data (MSB)
		4	IX + Offset + 1	0	Register Data (LSB)
		5	Op Code Address + 2	1	Next Op Code
JSR	5	1	Op Code Address + 1	1	Offset
		2	FFFF	1	Restart Address (LSB)
		3	Stack Pointer	0	Return Address (LSB)
		4	Stack Pointer - 1	0	Return Address (MSB)
		5	IX + Offset	1	First Subroutine Op Code
ASL ASR COM DEC INC LSR NEG ROL ROR	6	1	Op Code Address + 1	1	Offset
		2	FFFF	1	Restart Address (LSB)
		3	IX + Offset	1	Operand Data
		4	FFFF	1	Restart Address (LSB)
		5	IX + Offset	0	New Operand Data
		6	Op Code Address + 2	1	Next Op Code
TIM	5	1	Op Code Address + 1	1	Immediate Data
		2	Op Code Address + 2	1	Offset
		3	FFFF	1	Restart Address (LSB)
		4	IX + Offset	1	Operand Data
		5	Op Code Address + 3	1	Next Op Code
CLR	5	1	Op Code Address + 1	1	Offset
		2	FFFF	1	Restart Address (LSB)
		3	IX + Offset	1	Operand Data
		4	IX + Offset	0	00
		5	Op Code Address + 2	1	Next Op Code
AIM EIM OIM	7	1	Op Code Address + 1	1	Immediate Data
		2	Op Code Address + 2	1	Offset
		3	FFFF	1	Restart Address (LSB)
		4	IX + Offset	1	Operand Data
		5	FFFF	1	Restart Address (LSB)
		6	IX + Offset	0	New Operand Data
		7	Op Code Address + 3	1	Next Op Code

- Continued -

Table 12 Cycle-by-Cycle Operation (Continued)

Address Mode & Instructions	Cycles	Cycle #	Address Bus	R W	Data Bus
EXTEND					
JMP	3	1	Op Code Address + 1	1	Jump Address (MSB)
		2	Op Code Address + 2	1	Jump Address (LSB)
		3	Jump Address	1	Next Op Code
ADC ADD TST AND BIT CMP EOR LDA ORA SBC SUB	4	1	Op Code Address + 1	1	Address of Operand (MSB)
		2	Op Code Address + 2	1	Address of Operand (LSB)
		3	Address of Operand	1	Operand Data
		4	Op Code Address + 3	1	Next Op Code
STA	4	1	Op Code Address + 1	1	Destination Address (MSB)
		2	Op Code Address + 2	1	Destination Address (LSB)
		3	Destination Address	0	Accumulator Data
		4	Op Code Address + 3	1	Next Op Code
ADDD CPX LDD LDS LDX SUBD	5	1	Op Code Address + 1	1	Address of Operand (MSB)
		2	Op Code Address + 2	1	Address of Operand (LSB)
		3	Address of Operand	1	Operand Data (MSB)
		4	Address of Operand + 1	1	Operand Data (LSB)
		5	Op Code Address + 3	1	Next Op Code
STD STS STX	5	1	Op Code Address + 1	1	Destination Address (MSB)
		2	Op Code Address + 2	1	Destination Address (LSB)
		3	Destination Address	0	Register Data (MSB)
		4	Destination Address + 1	0	Register Data (LSB)
		5	Op Code Address + 3	1	Next Op Code
JSR	6	1	Op Code Address + 1	1	Jump Address (MSB)
		2	Op Code Address + 2	1	Jump Address (LSB)
		3	FFFF	1	Restart Address (LSB)
		4	Stack Pointer	0	Return Address (LSB)
		5	Stack Pointer - 1	0	Return Address (MSB)
		6	Jump Address	1	First Subroutine Op Code
ASL ASR COM DEC INC LSR NEG ROL ROR	6	1	Op Code Address + 1	1	Address of Operand (MSB)
		2	Op Code Address + 2	1	Address of Operand (LSB)
		3	Address of Operand	1	Operand Data
		4	FFFF	1	Restart Address (LSB)
		5	Address of Operand	0	New Operand Data
		6	Op Code Address + 3	1	Next Op Code
CLR	5	1	Op Code Address + 1	1	Address of Operand (MSB)
		2	Op Code Address + 2	1	Address of Operand (LSB)
		3	Address of Operand	1	Operand Data
		4	Address of Operand	0	00
		5	Op Code Address + 3	1	Next Op Code

- Continued -



Table 12 Cycle-by-Cycle Operation (Continued)

Address Mode & Instructions		Cycles	Cycle #	Address Bus	R/W	Data Bus	
IMPLIED							
ABA	ABX	1	1	Op Code Address + 1	1	Next Op Code	
ASL	ASLD						
ASR	CBA						
CLC	CLI						
CLR	CLV						
COM	DEC						
DES	DEX						
INC	INS						
INX	LSR						
LSRD	ROL						
ROR	NOP						
SBA	SEC						
SEI	SEV						
TAB	TAP						
TBA	TPA						
TST	TSX						
TXS							
DAA	XGDX	2	1	Op Code Address + 1	1	Next Op Code	
			2	FFFF	1	Restart Address (LSB)	
PULA	PULB	3	1	Op Code Address + 1	1	Next Op Code	
			2	FFFF	1	Restart Address (LSB)	
			3	Stack Pointer + 1	1	Data from Stack	
PSHA	PSHB	4	1	Op Code Address + 1	1	Next Op Code	
			2	FFFF	1	Restart Address (LSB)	
PULX		4	3	Stack Pointer	0	Accumulator Data	
			4	Op Code Address + 1	1	Next Op Code	
			1	Op Code Address + 1	1	Next Op Code	
			2	FFFF	1	Restart Address (LSB)	
PSHX		5	3	Stack Pointer + 1	1	Data from Stack (MSB)	
			4	Stack Pointer + 2	1	Data from Stack (LSB)	
			1	Op Code Address + 1	1	Next Op Code	
			2	FFFF	1	Restart Address (LSB)	
RTS		5	3	Stack Pointer	0	Index Register (LSB)	
			4	Stack Pointer - 1	0	Index Register (MSB)	
			5	Op Code Address + 1	1	Next Op Code	
			1	Op Code Address + 1	1	Next Op Code	
			2	FFFF	1	Restart Address (LSB)	
MUL		7	3	Stack Pointer + 1	1	Return Address (MSB)	
			4	Stack Pointer + 2	1	Return Address (LSB)	
			5	Return Address	1	First Op Code of Return Routine	
			1	Op Code Address + 1	1	Next Op Code	
			2	FFFF	1	Restart Address (LSB)	
			3	FFFF	1	Restart Address (LSB)	
			4	FFFF	1	Restart Address (LSB)	
5	FFFF	1	Restart Address (LSB)				
6	FFFF	1	Restart Address (LSB)				
7	FFFF	1	Restart Address (LSB)				

- Continued -



Table 12 Cycle-by-Cycle Operation (Continued)

Address Mode & Instructions	Cycles	Cycle #	Address Bus	R/W	Data Bus
IMPLIED					
WAI	9	1	Op Code Address + 1	1	Next Op Code
		2	FFFF	1	Restart Address (LSB)
		3	Stack Pointer	0	Return Address (LSB)
		4	Stack Pointer - 1	0	Return Address (MSB)
		5	Stack Pointer - 2	0	Index Register (LSB)
		6	Stack Pointer - 3	0	Index Register (MSB)
		7	Stack Pointer - 4	0	Accumulator A
		8	Stack Pointer - 5	0	Accumulator B
		9	Stack Pointer - 6	0	Conditional Code Register
RTI	10	1	Op Code Address + 1	1	Next Op Code
		2	FFFF	1	Restart Address (LSB)
		3	Stack Pointer + 1	1	Conditional Code Register
		4	Stack Pointer + 2	1	Accumulator B
		5	Stack Pointer + 3	1	Accumulator A
		6	Stack Pointer + 4	1	Index Register (MSB)
		7	Stack Pointer + 5	1	Index Register (LSB)
		8	Stack Pointer + 6	1	Return Address (MSB)
		9	Stack Pointer + 7	1	Return Address (LSB)
		10	Return Address	1	First Op Code of Return Routine
SWI	12	1	Op Code Address + 1	1	Next Op Code
		2	FFFF	1	Restart Address (LSB)
		3	Stack Pointer	0	Return Address (LSB)
		4	Stack Pointer - 1	0	Return Address (MSB)
		5	Stack Pointer - 2	0	Index Register (LSB)
		6	Stack Pointer - 3	0	Index Register (MSB)
		7	Stack Pointer - 4	0	Accumulator A
		8	Stack Pointer - 5	0	Accumulator B
		9	Stack Pointer - 6	0	Conditional Code Register
		10	Vector Address FFFA	1	Address of SWI Routine (MSB)
		11	Vector Address FFFB	1	Address of SWI Routine (LSB)
		12	Address of SWI Routine	1	First Op Code of SWI Routine
SLP	4	1	Op Code Address + 1	1	Next Op Code
		2	FFFF	1	Restart Address (LSB)
		3	FFFF		High Impedance-Non MPX Mode Address Bus -MPX Mode
		4	Op Code Address + 1		Restart Address (LSB) Next Op Code

- Continued -

2



Table 12 Cycle-by-Cycle Operation (Continued)

Address Mode & Instructions	Cycles	Cycle #	Address Bus	R W	Data Bus
RELATIVE					
BCC BCS	3	1	Op Code Address + 1	1	Branch Offset
BEQ BGE		2	FFFF	1	Restart Address (LSB)
BGT BHI		3	{ Branch Address.....Test="1" Op Code Address+1...Test="0"	1	First Op Code of Branch Routine Next Op Code
BLE BLS					
BLT BMT					
BNE BPL	5	3	Stack Pointer	0	Return Address (LSB)
BRA BRN		4	Stack Pointer - 1	0	Return Address (MSB)
BVC BVS		5	Branch Address	1	First Op Code of Subroutine
BSR		1	Op Code Address + 1	1	Offset
		2	FFFF	1	Restart Address (LSB)
	3	Stack Pointer	0	Return Address (LSB)	
	4	Stack Pointer - 1	0	Return Address (MSB)	
	5	Branch Address	1	First Op Code of Subroutine	

■ **LOW POWER CONSUMPTION MODE**

The HD6303R has two low power consumption modes; sleep and standby mode.

● **Sleep Mode**

On execution of SLP instruction, the MPU is brought to the sleep mode. In the sleep mode, the CPU stops its operation, but the contents of the registers in the CPU are retained. In this mode, the peripherals of CPU will remain active. So the operations such as transmit and receive of the SCI data and counter may keep in operation. In this mode, the power consumption is reduced to about 1/6 the value of a normal operation.

The escape from this mode can be done by interrupt, RES, STBY. The RES resets the MPU and the STBY brings it into the standby mode (This will be mentioned later). When interrupt is requested to the CPU and accepted, the sleep mode is released, then the CPU is brought in the operation mode and jumps to the interrupt routine. When the CPU has masked the interrupt, after recovering from the sleep mode, the next instruction of SLP starts to execute. However, in such a case that the timer interrupt is inhibited on the timer side, the sleep mode cannot be released due to the absence of the interrupt request to the CPU.

This sleep mode is available to reduce an average power consumption in the applications of the HD6303R which may not be always running.

● **Standby Mode**

Bringing STBY "Low", the CPU becomes reset and all clocks of the HD6303R become inactive. It goes into the standby mode. This mode remarkably reduces the power consumptions of the HD6303R.

In the standby mode, if the HD6303R is continuously supplied with power, the contents of RAM is retained. The standby mode should escape by the reset start. The following is the typical application of this mode.

First, NMI routine stacks the CPU's internal information and the contents of SP in RAM, disables RAME bit of RAM control register, sets the standby bit, and then goes into the standby mode. If the standby bit keeps set on reset start, it means that the power has been kept during stand-by mode and the contents of RAM is normally guaranteed. The system recovery may be possible by returning SP and bringing into the condition before the standby mode has started. The timing relation for each line in this application is shown in Figure 21.

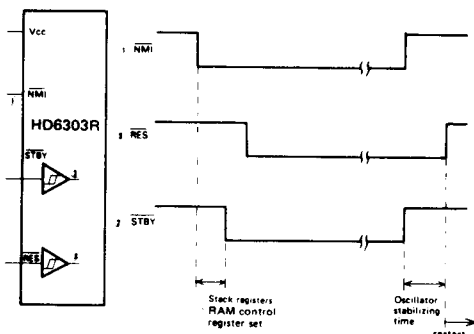

Figure 21 Standby Mode Timing

■ ERROR PROCESSING

When the HD6303R fetches an undefined instruction or fetches an instruction from unusable memory area, it generates the highest priority internal interrupt, that may protect from system upset due to noise or a program error.

● Op-Code Error

Fetching an undefined op-code, the HD6303R will stack the CPU register as in the case of a normal interrupt and vector to the TRAP (\$FFEE, \$FFEF), that has a second highest priority (RES is the highest).

● Address Error

When an instruction is fetched from other than a resident RAM, or an external memory area, the CPU starts the same interrupt as op-code error. In the case which the instruction is fetched from external memory area and that area is not usable, the address error can not be detected.

The address which cause address error are shown in Table 13.

This feature is applicable only to the instruction fetch, not to normal read/write of data accessing.

Transitions among the active mode, sleep mode, standby mode and reset are shown in Figure 22.

Figures 23, 24 show a system configuration.

The system flow chart of HD6303R is shown in Figure 25.

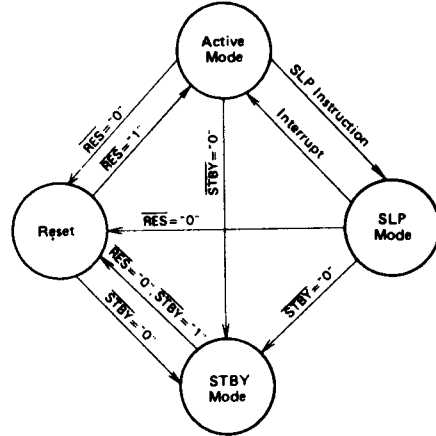

Figure 22 Transitions among Active Mode, Standby Mode, Sleep Mode, and Reset

Table 13 Address Error

Address Error
\$0000 ~ \$001F

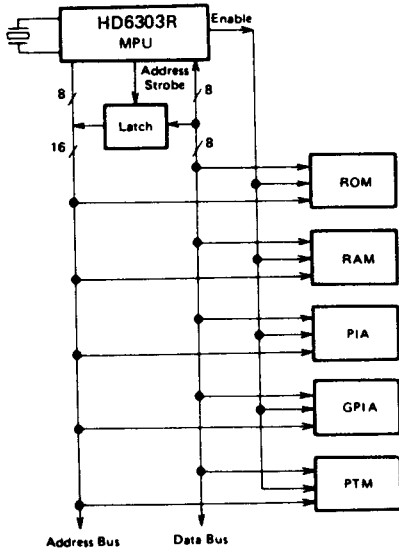

Figure 23 HD6303R MPU Multiplexed Mode

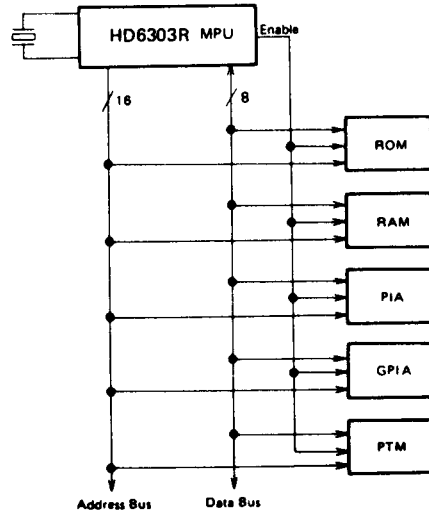

Figure 24 HD6303R MPU Non-Multiplexed Mode

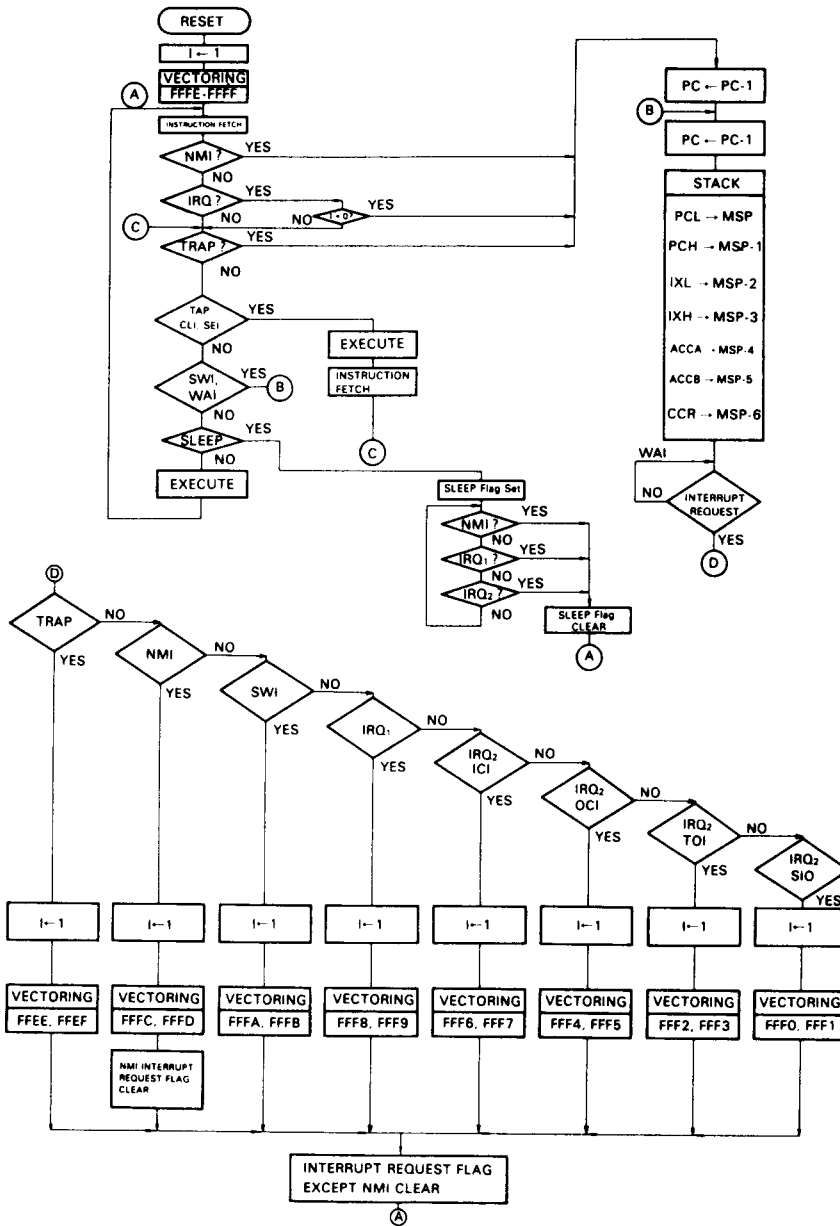
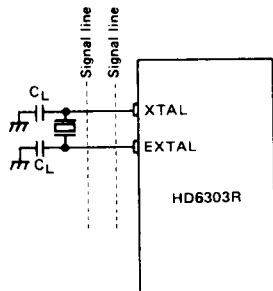

Figure 25 HD6303R System Flow Chart



■ PRECAUTION TO THE BOARD DESIGN OF OSCILLATION CIRCUIT

As shown in Fig. 26, there is a case that the cross talk disturbs the normal oscillation if signal lines are put near the oscillation circuit. When designing a board, pay attention to this. Crystal and C_L must be put as near the HD6303R as possible.



Do not use this kind of print board design.

Figure 26 Precaution to the board design of oscillation circuit

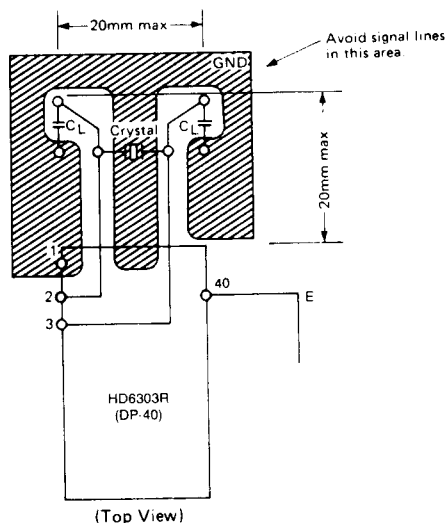

Fig. 27 Example of Oscillation Circuits in Board Design

■ PIN CONDITIONS AT SLEEP AND STANDBY STATE

● Sleep State

The conditions of power supply pins, clock pins, input pins and E clock pin are the same as those of operation. Refer to Table 14 for the other pin conditions.

● Standby State

Only power supply pins and STBY are active. As for the clock pin EXTAL, its input is fixed internally so the MPU is not influenced by the pin conditions. XTAL is in "1" output. All the other pins are in high impedance.

Table 14 Pin Condition in Sleep State

Pin	Mode	Non Multiplexed Mode	Multiplexed Mode
	P ₂₀ ~ P ₂₄	Function	I/O Port
Condition		Keep the condition just before sleep	→
A ₀ /P ₁₀ ~ A ₇ /P ₁₇	Function	Address Bus (A ₀ ~ A ₇)	I/O Port
	Condition	Output "1"	Keep the condition just before sleep
A ₈ ~ A ₁₅	Function	Address Bus (A ₈ ~ A ₁₅)	Address Bus (A ₈ ~ A ₁₅)
	Condition	Output "1"	→
D ₀ /A ₀ ~ D ₇ /A ₇	Function	Data Bus (D ₀ ~ D ₇)	E: Address Bus (A ₀ ~ A ₇), E: Data Bus
	Condition	High Impedance	E: Output "1", E: High Impedance
R/W	Function	R/W Signal	R/W Signal
	Condition	Output "1"	→
AS		→	Output AS



Table 15 Pin Condition during RESET

Pin \ Mode	Non-Multiplexed Mode	Multiplexed Mode
P ₂₀ ~ P ₂₄	High Impedance	←
A ₀ /P ₁₀ ~ A ₇ /P ₁₇	High Impedance	←
A ₈ ~ A ₁₅	High Impedance	←
D ₀ /A ₀ ~ D ₇ /A ₇	High Impedance	E : "1" Output E : "1" Output ^(Note) (High Impedance)
R/ \bar{W}	"1" Output	←
AS	E : "1" Output E : High Impedance	←

(Note) In the multiplexed mode, the data bus is set to "1" output state during E = "1" and it causes the conflict with the output of external memory. Following 1 and 2 should be done to avoid the conflict:

- (1) Construct the system that disables the external memory during reset.
- (2) Add 4.7 kΩ pull-down resistance to the AS pin to make AS pin "0" level during E = "1". This operation makes the data bus high impedance state.

■ DIFFERENCE BETWEEN HD6303 AND HD6303R

The HD6303R is an upgraded version of the HD6303. The difference between HD6303 and HD6303R is shown in Table 16.

Table 16 Difference between HD6303 and HD6303R

Item	HD6303	HD6303R
Operating Mode	Mode 2: Not defined	Mode 2: Multiplexed Mode (Equivalent to Mode 4)
Electrical Characteristics	The electrical characteristics of 2MHz version (B version) are not specified.	Some characteristics are improved. The 2MHz version is guaranteed.
Timer	Has problem in output compare function. (Can be avoided by software.)	The problem is solved.

■ RECEIVE MARGIN OF THE SCI

Receive margin of the SCI contained in the HD6303R is shown in Table 17.

Note: SCI = Serial Communication Interface

Table 17

	Bit distortion tolerance (t-to) / t ₀	Character distortion tolerance (T-T ₀) / T ₀
HD6303R	±37.5%	+3.75% -2.5%

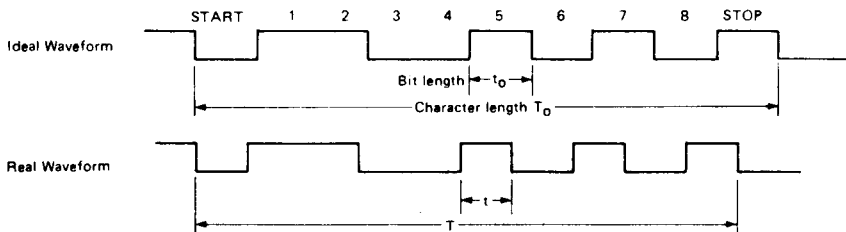

■ APPLICATION NOTE FOR HIGH SPEED SYSTEM DESIGN USING THE HD6303R

This note describes the solutions of the potential problem caused by noise generation in the system using the HD6303R.

The CMOS ICs and LSIs featured by low power consumption

and high noise immunity are generally considered to be enough with simply designed power source and the GND line.

But this does not apply to the applications configured of high speed system or of high speed parts. Such high speed system may have a chance to work incorrectly because of the noise

by the transient current generated during switching. One of example is a system in which the HD6303R directly accesses high speed memory such as the HM6264. The noise generation owing to the over current (Sometimes it may be several hundreds mA for peak level.) during switching may cause data write error.

This noise problem may be observed only at the Expanded Mode (Mode 1, 2, 4, 5 and 6) of the HD6303R.

Assuming the HD6303R is used as CPU in a system.

I. Noise Occurrence

If the HD6303R is connected to high speed RAM, a write error may occur. As shown in Fig. 28, the noise is generated in address bus during write cycle and data is written into an unexpected address from the HD6303R. This phenomenon causes random failures in systems whose data bus load capacitance exceeds the specification value (90 pF max.) and/or the impedance of the GND line is high.

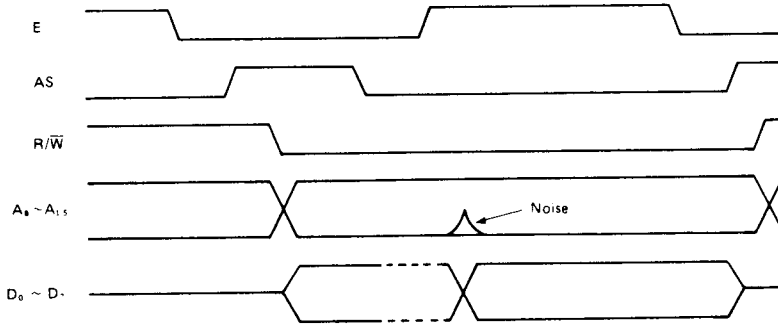

Fig. 28 Noise Occurrence in address bus during write cycle

If the data bus D₀ ~ D₇ changes from "FF" to "00", extremely large transient current flows through the GND line. Then the noise is generated on the LSI's V_{SS} pins proportioning to the transient current and to the impedance [Z_g] of the GND line.

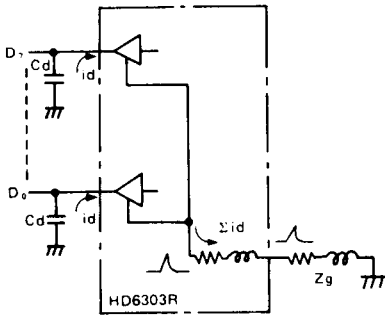

Fig. 29 Noise Source

This noise level, V_n, appears on all output pins on the LSI including the address bus.

Fig. 30 shows the dependency of the noise voltage on the each parameter.

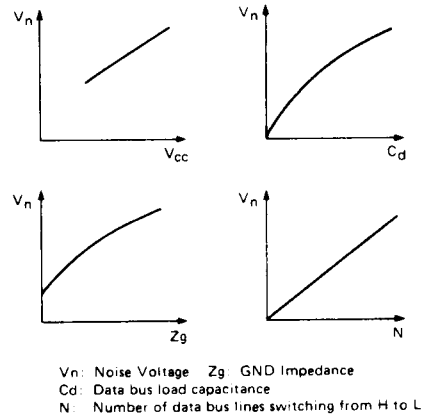

Fig. 30 Dependency of the noise voltage on each parameter

II. Noise Protection

To avoid the noise on the address bus during the system operation mentioned before, there are two solutions as follows:

The one method is to isolate the HD6303R from peripheral devices so that peripherals are not affected by the noise. The other is to reduce noise level to the extent of not affecting peripherals using analog method.



HD6303R, HD63A03R, HD63B03R

1. Noise Isolation

Addresses should be latched at the negative edge of the AS signal or at the positive edge of the E signal. The 74LS373 is often used in this case.

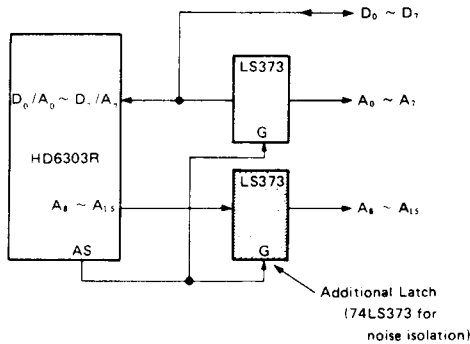

2. Noise Reduction

As the noise level depends on each parameter such as C_d , V_{CC} , Z_g , the noise level can be reduced to the allowable level by controlling those analog parameters.

(a) Transient Current Reduction

- (1) Reduce the data bus load capacitance. If large load capacitance is expected, a bus buffer should be inserted.
- (2) Lower the power supply voltage V_{CC} within specification.
- (3) Increase a time constant at transient state by inserting a resistor (100 ~ 200 Ω) to Data Buses in series to keep noise level down. Table 18 shows the relationship between a series resistor and noise level or a resistor and DC/AC characteristics.

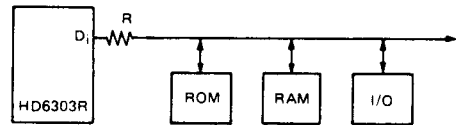

Table 18.

Item	Resistor		No	100 Ω	200 Ω
	Noise Voltage Level		See Fig. 31		
DC Characteristics		I_{OL}	1.6 mA	1.6 mA	1.0 mA
AC Characteristics	f = 1 MHz	No change			
		t_{ADL}	190 ns	190 ns	210 ns
	f = 1.5 MHz	t_{ACCM}	395 ns	395 ns	375 ns
		t_{ADL}	160 ns	180 ns	200 ns
	f = 2 MHz	t_{ASL}	20 ns	20 ns	0 ns
t_{ACCM}		270 ns	250 ns	230 ns	

Fig. 31 shows an example of the dependency of the noise voltage on the load capacitance of the data bus.*

*Note: The value of series resistor should be carefully selected because it heavily depends on each parameter of actual application system.

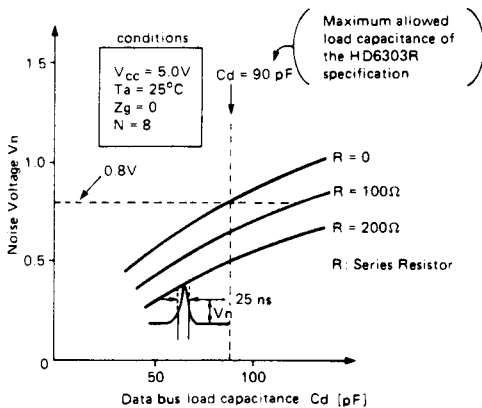

Fig. 31

Fig. 32 shows the typical wave form of the noise.

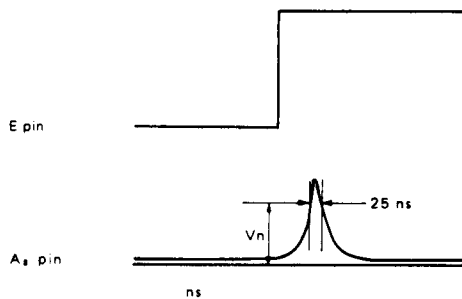

Fig. 32



(b) Reduction of GND line impedance

- (1) Widen the GND line width on the PC board.
- (2) Place the HD6303R close to power source.

- (3) Insert a bypass capacitor between the V_{CC} line and the GND of the HD6303R. A tantalum capacitor (about $0.1\mu\text{F}$) is effective on the reduction.

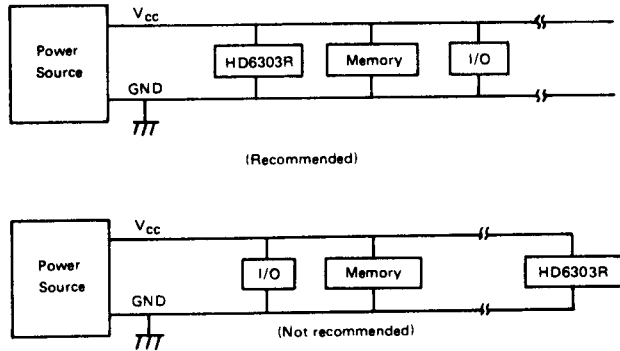

Fig. 33 Layout of the HD6303R on the PC board

■ **WARNING CONCERNING POWER START-UP**

$\overline{\text{RES}}$ must be held low for at least 20 ms when the power starts up. In this case, the internal reset function is not effective until the oscillation begins at power-on. The $\overline{\text{RES}}$ signal is input to the LSI in synchronism with the internal clock ϕ (shown in Figure 34.)

Therefore, after power starts up, the LSI conditions such as its I/O ports and operating mode, are unstable. Fix the level of I/O ports by means of an external circuit to determine the level for system operation during the oscillator stabilization time.

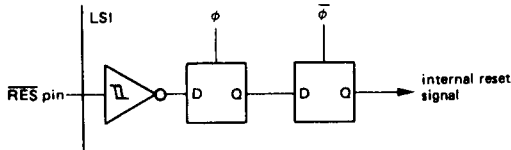

Figure 34 $\overline{\text{RES}}$ circuit

■ **NOTICE ON HD6303R**

The HD6303R is the same die as the HD6301V1. The on-chip Mask ROM is disabled by mask option; therefore not all modes of operation are available on the HD6303R. Please note that wherever HD6301V1 is referenced, the information also applies to the HD6303R.

■ **NOTICE ON HD6303R1**

The HD6303R has been upgraded to HD6303R1. Refer to the following figures for differences between the devices. All other characteristics remain the same.

HD6303R, HD63A03R, HD63B03R

■ DIFFERENCES BETWEEN HD6301V1, HD6303R, HD6303R1, HD63P01M1, AND HD63701V0

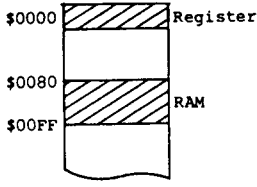
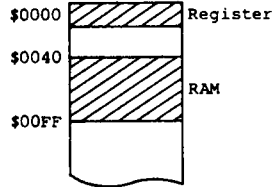
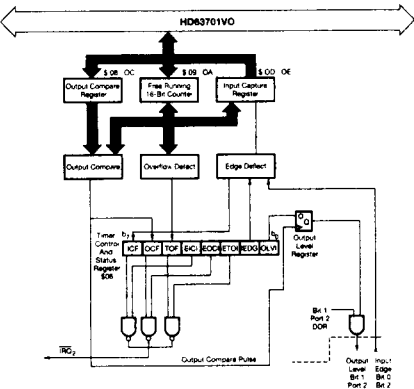
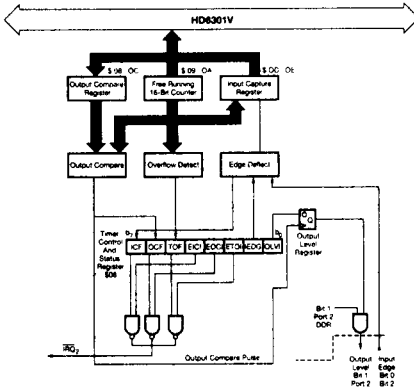
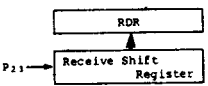
Item	HD6301V	HD63701V0
RAM	<p>RAM Size: 128-byte Address: \$0080-\$00FF</p> 	<p>RAM Size: 192-byte Address: \$0040-\$00FF</p> 
Operation Mode	Mode 4: Expanded Multiplexed Mode = Mode 2	HD63701V0 does not have Mode 4
Function	<p>After providing supply voltage, output level is undefined (0 or 1) unless the contents of the Output Compare Register matches with those of the Free Running Counter. The Output Level Register is not initialized by reset.</p>  <p>Figure 20 Programmable Timer Block Diagram</p>	<p>The Output Level Register is initialized to 0 by reset.</p>  <p>Figure 20 Programmable Timer Block Diagram</p>
SCI	<p>HD6301V1, HD6303R, HD63P01M1</p> <p>When framing error occurs, receive data is not transferred from the Receive Shift Register to Receive Data Register (RDR).</p> 	<p>HD6303R1</p> <p>Receive data is transferred from Receive Shift Register to RDR even if framing error occurs.</p>



■ DIFFERENCES BETWEEN HD6301V1, HD6303R, HD6303R1, HD63P01M1, AND HD63701V0 (Continued)

Item	HD6301V	HD63701V0													
Port Reset	<p>The DDR of port is reset synchronously with E clock. I/O state is undefined from providing power supply till oscillation start (max. 20ms).</p>	<p>The DDR of port is reset asynchronously with E clock. CPU enters into high impedance state (input state) by bringing RES Low. Reset release and MCU internal reset is performed synchronously with E clock.</p>													
Standby Mode	<p>STBY signal is latched synchronously with E clock.</p>	<p>STBY signal is latched asynchronously with E clock. CPU enters into standby state by bringing STBY low.</p>													
Function AS (Address Strobe)	HD63P01M1	HD6301V1, HD6303R, HD6303R1	<p style="text-align: center;">During reset, AS functions normally.</p>												
	<p>In Expanded Multiplexed Mode (mode 0, 2, 4 or 6), AS becomes high impedance state for a half E clock cycle during reset. Therefore, I/O Port 3 functions as data bus during reset.</p>	<p>During reset, AS functions normally.</p>													
SCI Receive Margin	HD6301V1, HD6303R, HD6303R1	HD63P01M1	<p>The SCI receive margin is shown below.</p>												
	<p>The SCI receive margin is shown below.</p> <table border="1" style="width: 100%; border-collapse: collapse;"> <tr> <td style="width: 50%;">Bit distortion tolerance (t-t₀)/t₀</td> <td style="width: 50%; text-align: center;">± 37.5%</td> </tr> <tr> <td>Character distortion tolerance (T-T₀)/T₀</td> <td style="text-align: center;">+ 3.5% - 2.5%</td> </tr> </table>	Bit distortion tolerance (t-t ₀)/t ₀	± 37.5%	Character distortion tolerance (T-T ₀)/T ₀	+ 3.5% - 2.5%	<p>The SCI receive margin is shown below.</p> <table border="1" style="width: 100%; border-collapse: collapse;"> <tr> <td style="width: 50%;">Bit distortion tolerance (t-t₀)/t₀</td> <td style="width: 50%; text-align: center;">± 25%</td> </tr> <tr> <td>Character distortion tolerance (T-T₀)/T₀</td> <td style="text-align: center;">± 3.75%</td> </tr> </table>	Bit distortion tolerance (t-t ₀)/t ₀	± 25%	Character distortion tolerance (T-T ₀)/T ₀	± 3.75%	<table border="1" style="width: 100%; border-collapse: collapse;"> <tr> <td style="width: 80%;">Bit distortion tolerance (t-t₀)/t₀</td> <td style="width: 20%; text-align: center;">± 37.5%</td> </tr> <tr> <td>Character distortion tolerance (T-T₀)/T₀</td> <td style="text-align: center;">± 3.75%</td> </tr> </table>	Bit distortion tolerance (t-t ₀)/t ₀	± 37.5%	Character distortion tolerance (T-T ₀)/T ₀	± 3.75%
Bit distortion tolerance (t-t ₀)/t ₀	± 37.5%														
Character distortion tolerance (T-T ₀)/T ₀	+ 3.5% - 2.5%														
Bit distortion tolerance (t-t ₀)/t ₀	± 25%														
Character distortion tolerance (T-T ₀)/T ₀	± 3.75%														
Bit distortion tolerance (t-t ₀)/t ₀	± 37.5%														
Character distortion tolerance (T-T ₀)/T ₀	± 3.75%														



HD6303R, HD63A03R, HD63B03R

■ DIFFERENCES BETWEEN HD6301V1, HD6303R, HD6303R1, HD63P01M1, AND HD63701V0 (Continued)

Item	HD6301V		HD63701V0											
	HD6301V1, HD6303R, HD6303R1	HD63P01M1												
Function	Supply Voltage	$V_{CC} = 5V \pm 10\%$ (f = 0.1 ~ 2 MHz) $V_{CC} = 3 \sim 6V$ (f = 0.1 ~ 0.5 MHz)	$V_{CC} = 5V \pm 10\%$ (f = 0.1 ~ 1 MHz)	$V_{CC} = 5V \pm 10\%$ (f = 0.1 ~ 2 MHz)										
	Address/Data Hold Time (t_{AH} , t_{HW})	$t_{AH} = 20$ ns min. $t_{HW} = 20$ ns min. t_{AH} and t_{HW} are constant independently of operating frequency.		t_{AH} , $t_{HW} = 60$ ns (f = 1 MHz) $= 40$ ns (f = 1.5 MHz) $= 30$ ns (f = 2 MHz) t_{AH} and t_{HW} are proportion to 1/f. (f = operating frequency)										
Specification	Address Delay Time	(1) t_{AD1} and t_{AD2} are constant independently of operating frequency. In HD63B01V (B version of HD6301V), t_{AD1} and t_{AD2} are 160 ns max. at 0.1 MHz through 2 MHz operation. (2) t_{ADL} is related to operating frequency. (t_{ADL} is in proportion to 1/f. f = operating frequency)		t_{AD1} , t_{AD2} and t_{ADL} are related to operating frequency (They are in proportion to 1/f. f = operating frequency). Therefore, if HD637B01V operates at lower operating frequency, t_{AD1} , t_{AD2} and t_{ADL} will become 160 ns or more. t_{AD1} , t_{AD2} and t_{ADL} are calculated as follows. t_{AD} (f MHz) ≈ 250 ns (1 MHz) $\times 1/f$ (MHz)										
	I_{in} and C_{in} of \overline{RES}	$I_{in} = 1.0$ μ A max., $C_{in} = 12.5$ pF max.		$I_{in} = 10$ μ A max. $C_{in} = 50$ pF max. Since \overline{RES} is multiplexed with V_{PP} , C_{in} and I_{in} are larger than those of HD6301V.										
	Load Capacitance of E	2 - LSTTL + 40pF $I_{OL} = 0.8$ mA, $I_{OH} = -200$ μ A		1 - TTL + 90pF $I_{OL} = 1.6$ mA, $I_{OH} = -200$ μ A										
	Load Capacitance of Port 1	1 - TTL + 30pF		1 - TTL + 90pF										
	Spec. of Crystal Oscillator	Spec. $R_s = 600$ Ω .		Spec. <table border="1"> <thead> <tr> <th>Clock frequency (MHz)</th> <th>2.5</th> <th>4.0</th> <th>6.0</th> <th>8.0</th> </tr> </thead> <tbody> <tr> <td>R_s max. (Ω)</td> <td>500</td> <td>120</td> <td>80</td> <td>60</td> </tr> </tbody> </table>	Clock frequency (MHz)	2.5	4.0	6.0	8.0	R_s max. (Ω)	500	120	80	60
	Clock frequency (MHz)	2.5	4.0	6.0	8.0									
	R_s max. (Ω)	500	120	80	60									
Storage Temperature	$T_{stg} = -55 \sim +150^\circ\text{C}$		$T_{stg} = -55 \sim +125^\circ\text{C}$											

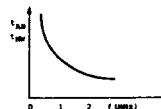

■ DIFFERENCES BETWEEN HD6301V1, HD6303R, HD6303R1, HD63P01M1, AND HD63701V0 (Continued)

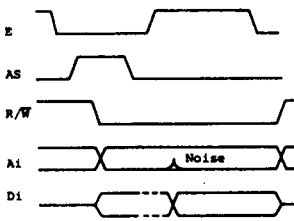
Item	HD6301V		HD63701V0
Function GND Noise	HD6301V1, HD6303R	HD6303R1, HD63P01M1	Noise is reduced by 50%.
	 <p data-bbox="282 537 591 705">If load capacitance in each data line and GND impedance are large, noise may appear on address bus during MCU write cycle and data won't be written into RAM correctly. The noise is caused by GND impedance which becomes large when large transient current flows into GND at High to Low transition of data line.</p>	Noise is reduced by 33%.	
Miscellaneous	Chip design and manufacturing process of the HD6301V differ from those of the HD63701V0. Therefore, actual spec. and margin are different between the HD6301V and the HD63701V0. Please carefully examine your system before applying HD6301V or HD63701V0 to your system.		

2