

*RoHS COMPLIANT

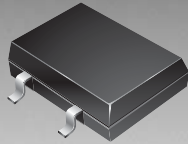

BOURNS®

Features

- RoHS compliant*
- Small SMT package
- High reliability with superior moisture resistance
- Applicable to automatic insertion



This series is currently available but not recommended for new designs.

Applications

- Switching power supply
- Home appliances, office equipment
- Telecommunication, factory automation

CDNBS04-B08200~B08800 Surface Mount Rectifier

General Information

The CDNBS04-B08200~B08800 device provides Bridge Rectification with high reliability with superior moisture resistance for home appliances, office equipment and telecommunications.

The device provide 0.8 A rectification with a choice of repetitive peak reverse voltages from 200 V to 800 V. The device measures 5 mm x 7 mm and is available in a four lead SMT package intended to be mounted directly onto an FR4 printed circuit board.

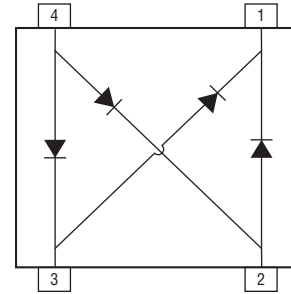

Electrical Characteristics (@ $T_A = 25\text{ }^\circ\text{C}$ Unless Otherwise Noted)

Parameter	Symbol	CDNBS04-				Unit
		B08200	B08400	B08600	B08800	
Maximum Repetitive Peak Reverse Voltage	V_{RRM}	200	400	600	800	V
Maximum RMS Voltage	V_{RMS}	140	280	420	560	V
Maximum DC Blocking Voltage	V_{DC}	200	400	600	800	V
Maximum Average Forward Rectified Current @ $T_A = 40\text{ }^\circ\text{C}$ ¹	$I_{(AV)}$	0.8				A
Maximum DC Reverse Current @ $T_J = 25\text{ }^\circ\text{C}$	I_R	5				μA
Maximum DC Reverse Current @ $T_J = 100\text{ }^\circ\text{C}$	I_R	100				μA
Maximum Forward Voltage @ 0.4 A DC	V_F	1.15				V
I^2t Rating for Fusing ($T < 8\text{ ms}$)	I^2t	3.7				A^2S
Maximum Recovery Time	T_{RR}	150		200	500	ns
Typical Thermal Resistance ²	$R_{\theta JA}$	50				$^\circ\text{C}/\text{W}$
Typical Junction Capacitance per element ³	C_J	13				pF
Peak forward surge current 8.3 ms single half sine-wave superimposed on rated load (JEDEC Method)	I_{FSM}	30				A

Notes:

- 1 Mounted on PC Board. See Forward Derating Curve.
- 2 Thermal Resistance from Junction to Ambient.
- 3 Measured at 1 MHz and applied Reverse Voltage of 4.0 VDC.

Thermal Characteristics (@ $T_A = 25\text{ }^\circ\text{C}$ Unless Otherwise Noted)

Parameter	Symbol	CDNBS04-B08200~B08800	Unit
Operating Temperature Range	T_J	-55 to +150	$^\circ\text{C}$
Storage Temperature Range	T_{STG}	-55 to +150	$^\circ\text{C}$

*RoHS Directive 2002/95/EC Jan 27, 2003 including Annex.
 Specifications are subject to change without notice.
 Customers should verify actual device performance in their specific applications.

CDNBS04-B08200~B08800 Surface Mount Rectifier



Product Dimensions

This is a molded package weighs approximately 0.125 g and can be mounted in any position. The dimensions for the packaged device are shown below.

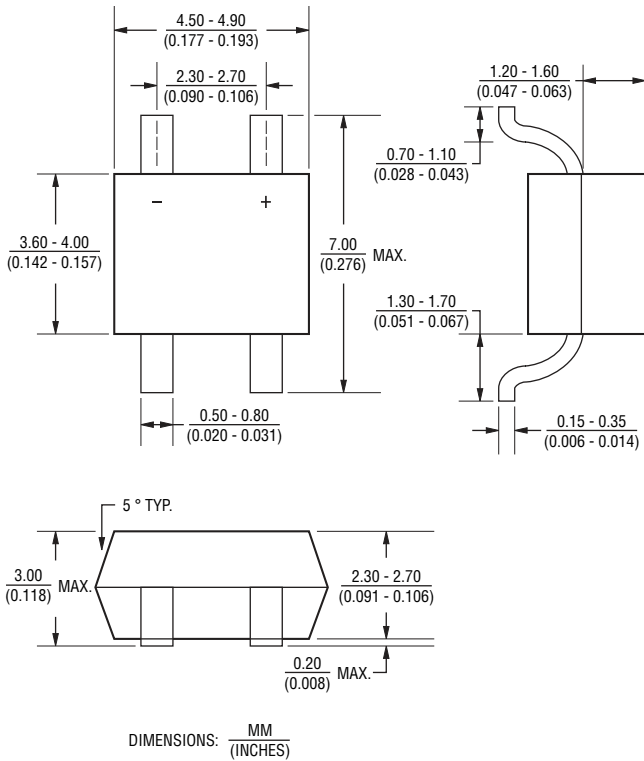

Recommended Footprint

The device will mount onto existing JEDEC SOD-106 footprint.

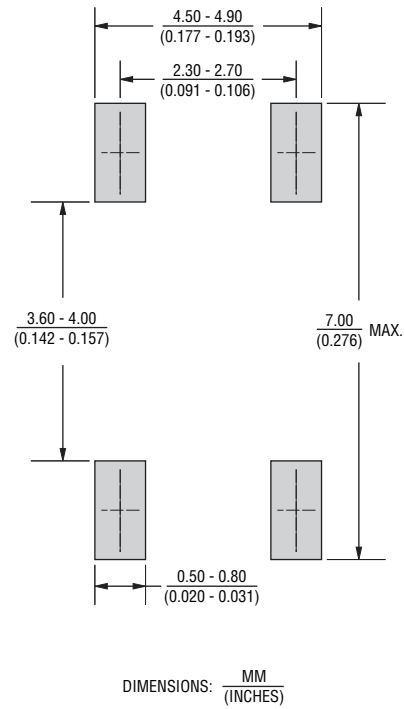

Block Diagram

The block diagram below includes the pin names and basic electrical connections associated with each channel.

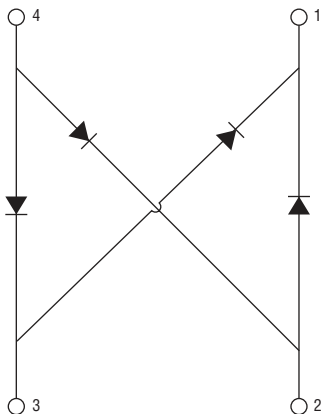

How To Order

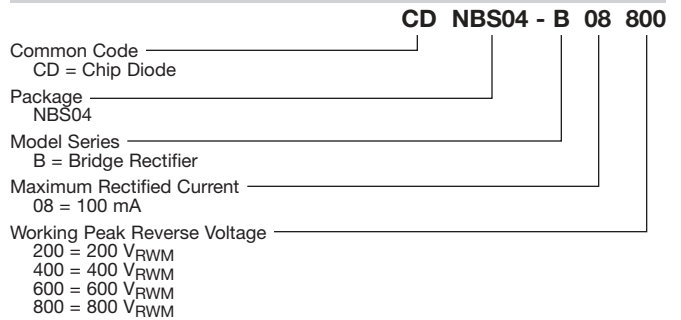

Typical Part Marking

CDNBS04-B08200	B 8 200
CDNBS04-B08400	B 8 400
CDNBS04-B08600	B 8 600
CDNBS04-B08800	B 8 800

CDNBS04-B08200~B08800 Surface Mount Rectifier



Packaging Specifications

The product will be dispensed in Tape and Reel format (see diagram below).

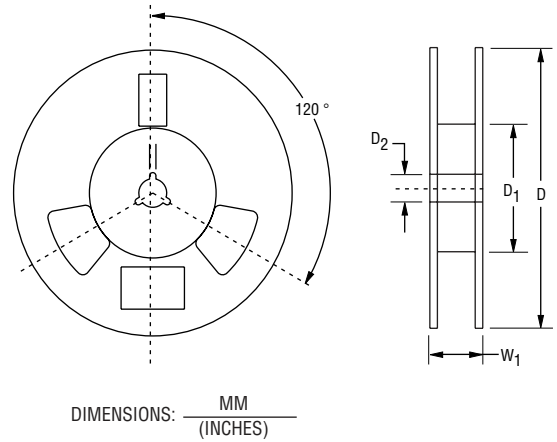
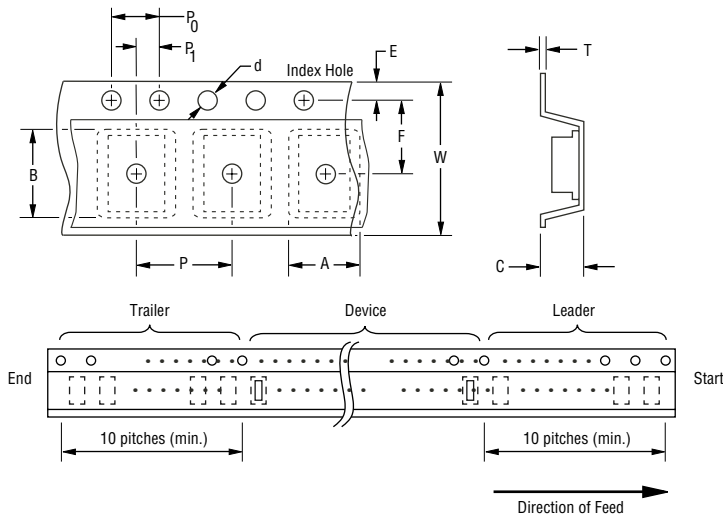

Devices are packed in accordance with EIA standard RS-481-A.

Item	Symbol	NSOIC 4L
Carrier Width	A	$\frac{6.7 \pm 0.10}{(0.264 \pm 0.004)}$
Carrier Length	B	$\frac{5.5 \pm 0.10}{0.217 \pm 0.004}$
Carrier Depth	C	$\frac{2.10 \pm 0.10}{0.083 \pm 0.004}$
Sprocket Hole	d	$\frac{1.55 \pm 0.05}{(0.061 \pm 0.002)}$
Reel Outside Diameter	D	$\frac{330}{(12.992)}$
Reel Inner Diameter	D1	$\frac{80.0}{(3.1500)}$ MIN.
Feed Hole Diameter	D2	$\frac{13.0 \pm 0.20}{(0.512 \pm 0.008)}$
Sprocket Hole Position	E	$\frac{1.75 \pm 0.10}{(0.069 \pm 0.004)}$
Punch Hole Position	F	$\frac{3.50 \pm 0.05}{(0.138 \pm 0.002)}$
Punch Hole Pitch	P	$\frac{8.00 \pm 0.10}{(0.315 \pm 0.004)}$
Sprocket Hole Pitch	P0	$\frac{4.00 \pm 0.10}{(0.157 \pm 0.004)}$
Embossment Center	P1	$\frac{2.00 \pm 0.05}{(0.079 \pm 0.002)}$
Overall Tape Thickness	T	$\frac{0.20 \pm 0.10}{(0.008 \pm 0.004)}$
Tape Width	W	$\frac{12.00 \pm 0.20}{(0.472 \pm 0.008)}$
Reel Width	W1	$\frac{18.4}{(0.724)}$ MAX.
Quantity per Reel	-	2500

Specifications are subject to change without notice. Customers should verify actual device performance in their specific applications.

Performance Graphs

Forward Current Derating Curve

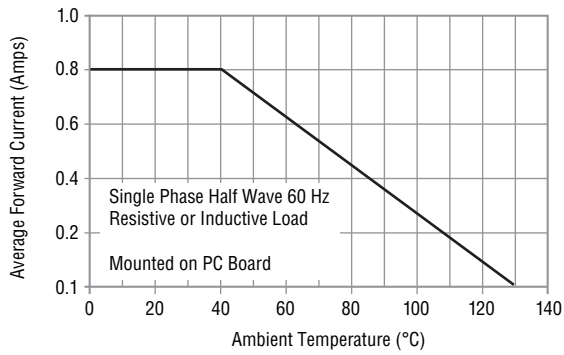

Maximum Non-Repetitive Surge Current

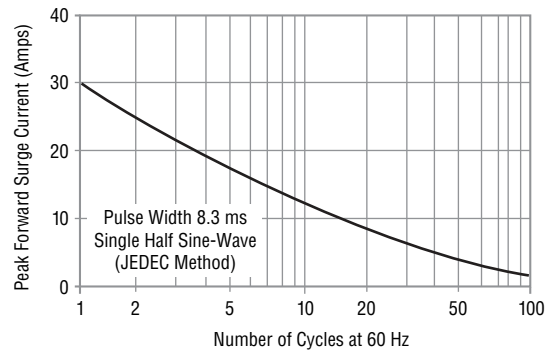

Typical Forward Characteristics

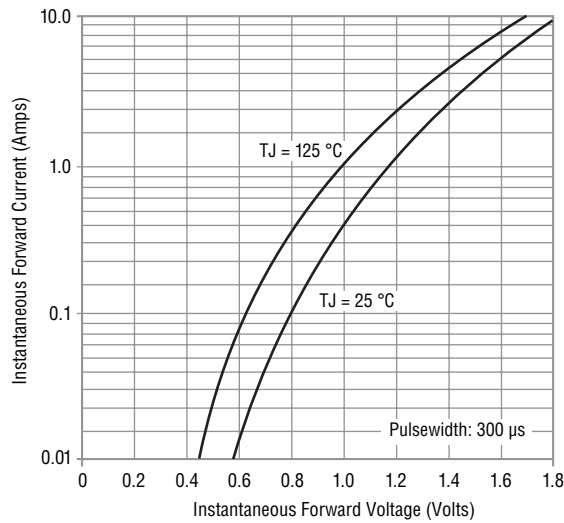

Typical Reverse Characteristics

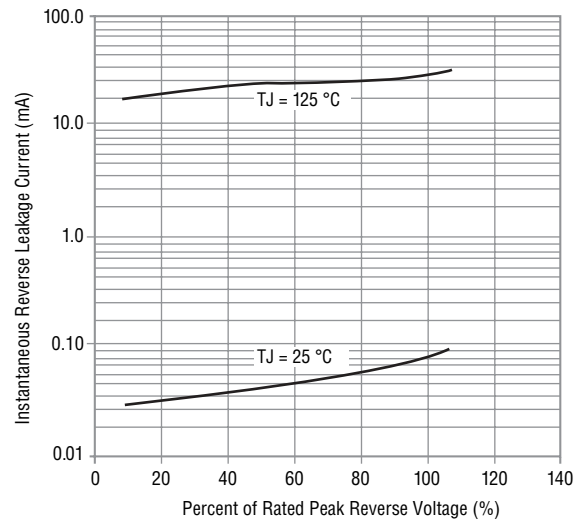

Typical Junction Capacitance

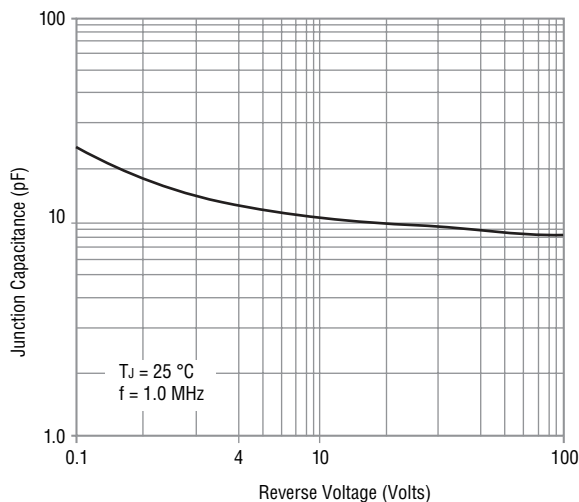

BOURNS®

Asia-Pacific:
 Tel: +886-2 2562-4117 • Fax: +886-2 2562-4116
Europe:
 Tel: +41-41 768 5555 • Fax: +41-41 768 5510
The Americas:
 Tel: +1-951 781-5500 • Fax: +1-951 781-5700
www.bourns.com