



Lead-free Green

PI7C9X3G816GP

PCI EXPRESS GEN 3 PACKET SWITCH
8-Port 16-Lane PCI Express Gen 3 Switch
DATASHEET
REVISION 2
September 2021



A Product Line of
Diodes Incorporated



1545 Barber Lane Milpitas, CA 95035
Telephone: 1-408-232-9100
FAX: 408-434-1040
Internet: <http://www.diodes.com>

IMPORTANT NOTICE

1. DIODES INCORPORATED AND ITS SUBSIDIARIES (“DIODES”) MAKE NO WARRANTY OF ANY KIND, EXPRESS OR IMPLIED, WITH REGARDS TO ANY INFORMATION CONTAINED IN THIS DOCUMENT, INCLUDING, BUT NOT LIMITED TO, THE IMPLIED WARRANTIES OF MERCHANTABILITY, FITNESS FOR A PARTICULAR PURPOSE OR NON-INFRINGEMENT OF THIRD PARTY INTELLECTUAL PROPERTY RIGHTS (AND THEIR EQUIVALENTS UNDER THE LAWS OF ANY JURISDICTION).
2. The Information contained herein is for informational purpose only and is provided only to illustrate the operation of Diodes products described herein and application examples. Diodes does not assume any liability arising out of the application or use of this document or any product described herein. This document is intended for skilled and technically trained engineering customers and users who design with Diodes products. Diodes products may be used to facilitate safety-related applications; however, in all instances customers and users are responsible for (a) selecting the appropriate Diodes products for their applications, (b) evaluating the suitability of the Diodes products for their intended applications, (c) ensuring their applications, which incorporate Diodes products, comply the applicable legal and regulatory requirements as well as safety and functional-safety related standards, and (d) ensuring they design with appropriate safeguards (including testing, validation, quality control techniques, redundancy, malfunction prevention, and appropriate treatment for aging degradation) to minimize the risks associated with their applications.
3. Diodes assumes no liability for any application-related information, support, assistance or feedback that may be provided by Diodes from time to time. Any customer or user of this document or products described herein will assume all risks and liabilities associated with such use, and will hold Diodes and all companies whose products are represented herein or on Diodes’ websites, harmless against all damages and liabilities.
4. Products described herein may be covered by one or more United States, international or foreign patents and pending patent applications. Product names and markings noted herein may also be covered by one or more United States, international or foreign trademarks and trademark applications. Diodes does not convey any license under any of its intellectual property rights or the rights of any third parties (including third parties whose products and services may be described in this document or on Diodes’ website) under this document.
5. Diodes products are provided subject to Diodes’ Standard Terms and Conditions of Sale (<https://www.diodes.com/about/company/terms-and-conditions/terms-and-conditions-of-sales/>) or other applicable terms. This document does not alter or expand the applicable warranties provided by Diodes. Diodes does not warrant or accept any liability whatsoever in respect of any products purchased through unauthorized sales channel.
6. Diodes products and technology may not be used for or incorporated into any products or systems whose manufacture, use or sale is prohibited under any applicable laws and regulations. Should customers or users use Diodes products in contravention of any applicable laws or regulations, or for any unintended or unauthorized application, customers and users will (a) be solely responsible for any damages, losses or penalties arising in connection therewith or as a result thereof, and (b) indemnify and hold Diodes and its representatives and agents harmless against any and all claims, damages, expenses, and attorney fees arising out of, directly or indirectly, any claim relating to any noncompliance with the applicable laws and regulations, as well as any unintended or unauthorized application.
7. While efforts have been made to ensure the information contained in this document is accurate, complete and current, it may contain technical inaccuracies, omissions and typographical errors. Diodes does not warrant that information contained in this document is error-free and Diodes is under no obligation to update or otherwise correct this information. Notwithstanding the foregoing, Diodes reserves the right to make modifications, enhancements, improvements, corrections or other changes without further notice to this document and any product described herein. This document is written in English but may be translated into multiple languages for reference. Only the English version of this document is the final and determinative format released by Diodes.
8. Any unauthorized copying, modification, distribution, transmission, display or other use of this document (or any portion hereof) is prohibited. Diodes assumes no responsibility for any losses incurred by the customers or users or any third parties arising from any such unauthorized use.

Copyright © 2021 Diodes Incorporated

www.diodes.com

REVISION HISTORY

Date	Revision Number	Description
04/26/2021	1	Datasheet Released
09/16/2021	2	Updated Chapter 9 Register Description Updated Chapter 15 Ordering Information

TABLE OF CONTENTS

1	INTRODUCTION	23
1.1	KEY FEATURES	24
2	GENERAL DESCRIPTION.....	26
3	PIN DESCRIPTION.....	28
3.1	PCI EXPRESS INTERFACE SIGNALS	28
3.2	CONFIGURATION STRAPPING SIGNALS	28
3.3	HOT PLUG SIGNALS	29
3.4	REFERENCE CLOCK OUTPUT AND CONTROL SIGNALS	30
3.5	SIDE BAND MANAGEMENT SIGNALS.....	31
3.6	MISCELLANEOUS CONTROL AND STATUS.....	31
3.7	JTAG BOUNDARY SCAN SIGNALS	32
3.8	POWER PINS	32
4	FUNCTIONAL OVERVIEW.....	35
4.1	MODES OF OPERATIONS	35
4.1.1	BASE MODE (FAN-OUT MODE).....	35
4.1.2	Cross-Domain End-Point Mode.....	35
4.2	PHYSICAL LAYER CIRCUITS	36
4.3	MEDIA ACCESS CONTROL (MAC).....	36
4.4	DATA LINK LAYER (DLL).....	37
4.5	TRANSACTION LAYER RECEIVE BLOCK (TLP DECAPSULATION)	37
4.6	ROUTING	37
4.7	QUEUE.....	38
4.7.1	POSTED REQUEST HEADER (PH).....	38
4.7.2	POST REQUEST DATA (PD).....	38
4.7.3	NON-POSTED REQUEST HEADER AND DATA (NPHD)	38
4.7.4	COMPLETION HEADER (CPLH)	38
4.7.5	COMPLETION DATA (CPLD).....	38
4.8	TRANSACTION ORDERING	39
4.9	PORT ARBITRATION.....	39
4.10	FLOW CONTROL.....	40
4.11	TRANSATION LAYER TRANSMIT BLOCK (TLP ENCAPSULATION).....	40
4.12	ACCESS CONTROL SERVICE (ACS)	40
4.13	MULTICAST OPERATION	40
5	CHIP INITIZATION	41
5.1	PORT-LANE CONFIGURATION	41
5.1.1	MODE SELECTION	41
5.1.2	LANE MAPPING	41
5.1.3	PORT NUMERING.....	41
5.1.4	PORT-LANE MAPPING.....	42
5.2	CLOCK SCHEME.....	42
5.2.1	REFERENCE CLOCK OPERATION MODES	42
5.2.2	INTEGRATED REFERENCE CLOCK BUFFER	43
5.3	EEPROM INTERFACE.....	44
5.3.1	EEPROM ACCESS MODES.....	44
5.3.2	EEPROM MODE AT RESET.....	44
5.3.3	EEPROM SPACE ADDRESS MAP.....	45
5.4	SMBUS INTERFACE	45

5.4.1	SMBUS BLOCK WRITE	46
5.4.2	SMBUS BLOCK READ.....	48
5.4.3	CSR READ, USING SMBUS BLOCK READ – BLOCK WRITE PROCESS CALL	50
5.5	I2C INTERFACE.....	51
5.5.1	I2C REGISTER WRITE ACCESS.....	52
5.5.2	I2C REGISTER READ ACCESS.....	54
6	HOT PLUG SUPPORT.....	57
6.1	HOT PLUG TYPES	57
6.1.1	SURPRISED SERIAL HOT PLUG.....	57
6.1.2	SURPRISED SERIAL HOT PLUG.....	57
6.1.3	SURPRISED PARALLEL HOT PLUG.....	58
6.1.4	MANAGED SERIAL HOT PLUG	59
6.2	TIMING SEQUENCE FOR SURPRISED HOT PLUG OPERATION	60
7	CROSS-DOMAIN END-POINT	61
7.1	GENERAL DESCRIPTION	61
7.1.1	FAIL-OVER.....	61
7.1.2	CO-PROCESSOR.....	61
7.2	PORT CONFIGURATION.....	62
7.3	BAR TRANSLATION FOR LOCAL HOST DOMAIN	62
7.3.1	DIRECT ADDRESS TRANSLATION (DAT).....	63
7.3.2	ADDRESS LOOK-UP TRANSLATION (ALUT).....	63
7.3.3	ID TRANSLATION.....	63
7.4	BAR TRANSLATION FOR PRIMARY HOST DOMAIN	63
7.5	SCRATCHPADS AND DOORBELLS	64
8	DIRECT MEMORY ACCESS	65
8.1	GENERAL DESCRIPTION	65
8.2	DMA CONFIGURATION.....	65
8.2.1	DMA FUNCTIONS	65
8.2.1.1	DMA MODE BIT DEFINITION	66
8.2.1.2	DMA MODE AND CD MODE	66
8.2.1.3	ENUMERATION.....	66
8.2.2	DMA CONTROL REGISTER.....	66
8.2.2.1	DMA DESCRIPTOR REGISTER.....	67
8.2.2.2	DMA OPERATIONAL REGISTER	67
8.3	DMA DESCRIPTORS AND TRANSFERS	68
8.3.1	DESCRIPTORS.....	68
8.3.1.1	INITIALIZATION	68
8.3.1.2	OWNERSHIP.....	68
8.3.1.3	PRE-FETCH.....	69
8.3.2	TRANSFER	69
8.3.2.1	LOCAL DOMAIN TRANSFER	69
8.3.2.2	CROSS DOMAIN TRANSFER.....	69
8.3.3	DESCRIPTOR LAYOUT.....	69
8.3.3.1	DOMAIN AND ADDRESS FIELD	70
8.3.3.2	TRANSFER COUNT FIELD	70
8.3.3.3	CONTROL FIELD	70
8.3.3.4	ERR FIELD	71
8.3.3.5	ST FIELD	71
8.3.3.6	CRC FIELD.....	72
8.4	ERROR REPORTING AND HANDLING	72
8.4.1	ERROR REPORTING	72
8.4.1.1	REPORTING VIA FUNCTION.....	72
8.4.1.2	REPORTING VIA CHANNEL.....	72
8.4.1.3	REPORTING VIA DESCRIPTOR	72

8.4.2	<i>ERROR LOGGING</i>	73
8.4.3	<i>DATA INTEGRITY</i>	73
8.4.4	<i>ERROR HANDLING FOR UNCORRECTABLE ERROR DETECTED</i>	73
8.4.4.1	<i>ERROR IN DATA BUFFER</i>	73
8.4.4.2	<i>ERROR IN DESCRIPTOR</i>	73
8.4.5	<i>ERROR HANDLING FOR DMA READ</i>	73
9	REGISTER DESCRIPTION	74
9.1	<i>REGISTER TYPES</i>	74
9.2	<i>REGISTER ACCESS</i>	74
9.2.1	<i>PCI-COMPATIBLE CONFIGURATION MECHANISM</i>	74
9.2.2	<i>PCI EXPRESS ENHANCED CONFIGURATION ACCESS MECHANISM</i>	74
9.2.3	<i>DEVICE_SPECIFIC MEMORY MAPPED CONFIGURATION MECHANISM</i>	74
9.3	<i>TRANSPARENT MODE CONFIGURATION REGISTERS</i>	76
9.3.1	<i>VENDOR ID REGISTER – OFFSET 00h</i>	81
9.3.2	<i>DEVICE ID REGISTER – OFFSET 00h</i>	81
9.3.3	<i>COMMAND REGISTER – OFFSET 04h</i>	81
9.3.4	<i>PRIMARY STATUS REGISTER – OFFSET 04h</i>	81
9.3.5	<i>REVISION ID REGISTER – OFFSET 08h</i>	82
9.3.6	<i>CLASS REGISTER – OFFSET 08h</i>	82
9.3.7	<i>CACHE LINE REGISTER – OFFSET 0Ch</i>	82
9.3.8	<i>PRIMARY LATENCY TIMER REGISTER – OFFSET 0Ch</i>	82
9.3.9	<i>HEADER TYPE REGISTER – OFFSET 0Ch</i>	82
9.3.10	<i>BASE ADDRESS 0 REGISTER – OFFSET 10h (Upstream Port Only)</i>	83
9.3.11	<i>BASE ADDRESS 1 REGISTER – OFFSET 14h (Upstream Port Only)</i>	83
9.3.12	<i>PRIMARY BUS NUMBER REGISTER – OFFSET 18h</i>	83
9.3.13	<i>SECONDARY BUS NUMBER REGISTER – OFFSET 18h</i>	83
9.3.14	<i>SUBORDINATE BUS NUMBER REGISTER – OFFSET 18h</i>	83
9.3.15	<i>SECONDARY LATENCY TIMER REGISTER – OFFSET 18h</i>	83
9.3.16	<i>I/O BASE ADDRESS REGISTER – OFFSET 1Ch</i>	84
9.3.17	<i>I/O LIMIT ADDRESS REGISTER – OFFSET 1Ch</i>	84
9.3.18	<i>SECONDARY STATUS REGISTER – OFFSET 1Ch</i>	84
9.3.19	<i>MEMORY BASE ADDRESS REGISTER – OFFSET 20h</i>	84
9.3.20	<i>MEMORY LIMIT ADDRESS REGISTER – OFFSET 20h</i>	85
9.3.21	<i>PREFETCHABLE MEMORY BASE ADDRESS REGISTER – OFFSET 24h</i>	85
9.3.22	<i>PREFETCHABLE MEMORY LIMIT ADDRESS REGISTER – OFFSET 24h</i>	85
9.3.23	<i>PREFETCHABLE MEMORY BASE ADDRESS UPPER 32-BITS REGISTER – OFFSET 28h</i>	85
9.3.24	<i>PREFETCHABLE MEMORY LIMIT ADDRESS UPPER 32-BITS REGISTER – OFFSET 2Ch</i>	85
9.3.25	<i>I/O BASE ADDRESS UPPER 16-BITS REGISTER – OFFSET 30h</i>	86
9.3.26	<i>I/O LIMIT ADDRESS UPPER 16-BITS REGISTER – OFFSET 30h</i>	86
9.3.27	<i>CAPABILITY POINTER REGISTER – OFFSET 34h</i>	86
9.3.28	<i>INTERRUPT LINE REGISTER – OFFSET 3Ch</i>	86
9.3.29	<i>INTERRUPT PIN REGISTER – OFFSET 3Ch</i>	86
9.3.30	<i>BRIDGE CONTROL REGISTER – OFFSET 3Ch</i>	86
9.3.31	<i>POWER MANAGEMENT CAPABILITIES REGISTER – OFFSET 40h</i>	87
9.3.32	<i>POWER MANAGEMENT DATA REGISTER – OFFSET 44h</i>	87
9.3.33	<i>PPB SUPPORT EXTENSIONS REGISTER – OFFSET 44h</i>	88
9.3.34	<i>DATA REGISTER – OFFSET 44h</i>	88
9.3.35	<i>MSI CAPABILITIES REGISTER – OFFSET 48h</i>	88
9.3.36	<i>MESSAGE ADDRESS REGISTER – OFFSET 4Ch</i>	88
9.3.37	<i>MESSAGE UPPER ADDRESS REGISTER – OFFSET 50h</i>	88
9.3.38	<i>MESSAGE DATA REGISTER – OFFSET 54h</i>	89
9.3.39	<i>MESSAGE MASK REGISTER – OFFSET 58h</i>	89
9.3.40	<i>MESSAGE PENDING REGISTER – OFFSET 5Ch</i>	89
9.3.41	<i>PCI EXPRESS CAPABILITIES REGISTER – OFFSET 68h</i>	89

9.3.42	DEVICE CAPABILITIES REGISTER – OFFSET 6Ch	90
9.3.43	DEVICE CONTROL REGISTER – OFFSET 70h	90
9.3.44	DEVICE STATUS REGISTER – OFFSET 70h	91
9.3.45	LINK CAPABILITIES REGISTER – OFFSET 74h	91
9.3.46	LINK CONTROL REGISTER – OFFSET 78h	92
9.3.47	LINK STATUS REGISTER – OFFSET 78h	93
9.3.48	SLOT CAPABILITIES REGISTER – OFFSET 7Ch (Downstream Port Only)	93
9.3.49	SLOT CONTROL REGISTER – OFFSET 80h (Downstream Port Only)	94
9.3.50	SLOT STATUS REGISTER – OFFSET 80h (Downstream Port Only)	94
9.3.51	DEVICE CAPABILITIES REGISTER 2 – OFFSET 8Ch	95
9.3.52	DEVICE CONTROL REGISTER 2 – OFFSET 90h	95
9.3.53	DEVICE STATUS REGISTER 2 – OFFSET 90h	96
9.3.54	LINK CAPABILITIES REGISTER 2 – OFFSET 94h	96
9.3.55	LINK CONTROL REGISTER 2 – OFFSET 98h	96
9.3.56	LINK STATUS REGISTER 2 – OFFSET 98h	97
9.3.57	SLOT CAPABILITIES REGISTER 2 – OFFSET 9Ch	97
9.3.58	SLOT CONTROL REGISTER 2 – OFFSET A0h	97
9.3.59	SLOT STATUS REGISTER 2 – OFFSET A0h	97
9.3.60	SSID/SSVID CAPATILITIES REGISTER – OFFSET A4h	97
9.3.61	SUBSYSTEM VENDOR ID REGISTER – OFFSET A8h	98
9.3.62	SUBSYSTEM ID REGISTER – OFFSET A8h	98
9.3.63	MSI-X CAPATILITIES REGISTER – OFFSET B0h (Upstream Port Only)	98
9.3.64	MSI-X TABLE OFFSET/TABLE BIR REGISTER – OFFSET B4h (Upstream Port Only)	98
9.3.65	MSI- X PBA OFFSET / PBA BIR REGISTER – OFFSET B8h (Upstream Port Only)	98
9.3.66	BAR 0 CONFIGURATION REGISTER – OFFSET E0h (Upstream Port Only)	98
9.3.67	BAR 0-1 CONFIGURATION REGISTER – OFFSET E4h (Upstream Port Only)	99
9.3.68	PCI EXPRESS ADVANCED ERROR REPORTING ENHANCED CAPABILITY HEADER REGISTER – OFFSET 100h	99
9.3.69	UNCORRECTABLE ERROR STATUS REGISTER – OFFSET 104h	100
9.3.70	UNCORRECTABLE ERROR MASK REGISTER – OFFSET 108h	100
9.3.71	UNCORRECTABLE ERROR SEVERITY REGISTER – OFFSET 10Ch	101
9.3.72	CORRECTABLE ERROR STATUS REGISTER – OFFSET 110h	102
9.3.73	CORRECTABLE ERROR MASK REGISTER – OFFSET 114h	102
9.3.74	ADVANCE ERROR CAPABILITIES AND CONTROL REGISTER – OFFSET 118h	103
9.3.75	HEADER LOG REGISTER – OFFSET From 11Ch to 128h	103
9.3.76	PCI EXPRESS VIRTUAL CHANNEL ENHANCED CAPABILITYHEADER REGISTER – OFFSET 130h 103	
9.3.77	PORT VC CAPABILITY REGISTER 1 – OFFSET 134h	103
9.3.78	PORT VC CAPABILITY REGISTER 2 – OFFSET 138h	104
9.3.79	PORT VC CONTROL REGISTER – OFFSET 13Ch	104
9.3.80	PORT VC STATUS REGISTER – OFFSET 13Ch	104
9.3.81	VC RESOURCE CAPABILITY REGISTER (0) – OFFSET 140h	104
9.3.82	VC RESOURCE CONTROL REGISTER (0) – OFFSET 144h	105
9.3.83	VC RESOURCE STATUS REGISTER (0) – OFFSET 148h	105
9.3.84	DEVICE SERIAL NUMBER ENHANCED CAPABILITY HEADER REGISTER – OFFSET 1A0h	105
9.3.85	DEVICE SERIAL NUMBER LOWER DW REGISTER – OFFSET 1A4h	105
9.3.86	DEVICE SERIAL NUMBER HIGHER DW REGISTER – OFFSET 1A8h	105
9.3.87	PCI EXPRESS POWER BUDGETING ENHANCED CAPABILITY HEADER REGISTER – OFFSET 1B0h (Upstream Port Only)	106
9.3.88	DATA SELECT REGISTER – OFFSET 1B4h (Upstream Port Only)	106
9.3.89	POWER BUDGETING DATA REGISTER – OFFSET 1B8h (Upstream Port Only)	106
9.3.90	POWER BUDGET CAPABILITY REGISTER – OFFSET 1BCh (Upstream Port Only)	106
9.3.91	ACS ENHANCED CAPABILITY HEADER REGISTER – OFFSET 1C0h (Downstream Port Only)	106
9.3.92	ACS CAPABILITY REGISTER – OFFSET 1C4h (Downstream Port Only)	107
9.3.93	EGRESS CONTROL VECTOR REGISTER – OFFSET 1C8h (Downstream Port Only)	107

9.3.94	MULTI-CAST ENHANCED CAPABILITY HEADER REGISTER – OFFSET 1D0h.....	107
9.3.95	MULTI-CAST CAPABILITY REGISTER – OFFSET 1D4h.....	108
9.3.96	MULTI-CAST CONTROL REGISTER – OFFSET 1D4h.....	108
9.3.97	MULTI-CAST BASE ADDRESS 0 REGISTER – OFFSET 1D8h.....	108
9.3.98	MULTI-CAST BASE ADDRESS 1 REGISTER – OFFSET 1DCh.....	108
9.3.99	MULTI-CAST RECEIVER REGISTER – OFFSET 1E0h.....	108
9.3.100	MULTI-CAST RECEIVER UPPER 32-BITS REGISTER – OFFSET 1E4h.....	108
9.3.101	MULTI-CAST BLOCK ALL REGISTER – OFFSET 1E8h.....	108
9.3.102	MULTI-CAST BLOCK ALL UPPER 32-BITS REGISTER – OFFSET 1ECh.....	109
9.3.103	MULTI-CAST BLOCK UNTRANSLATED REGISTER – OFFSET 1F0h.....	109
9.3.104	MULTI-CAST BLOCK UNTRANSLATED UPPER 32-BITS REGISTER – OFFSET 1F4h.....	109
9.3.105	LTR EXTENDED CAPABILITY HEADER – OFFSET 200h (Upstream Port Only).....	109
9.3.106	MAX SNOOP LATENCY REGISTER – OFFSET 204h (Upstream Port Only).....	109
9.3.107	MAX NO-SNOOP LATENCY REGISTER – OFFSET 204h (Upstream Port Only).....	109
9.3.108	SECONDARY PCI EXPRESS EXTENDED CAPABILITY HEADER – OFFSET 210h.....	110
9.3.109	LINK CONTROL 3 REGISTER – OFFSET 214h.....	110
9.3.110	LANE ERROR STATUS REGISTER – OFFSET 218h.....	110
9.3.111	LANE EQUALIZATION CONTROL REGISTER – OFFSET 21Ch – 230h.....	110
9.3.112	DPC EXTENDED CAPABILITY HEADER – OFFSET 2A0h (Downstream Port Only).....	111
9.3.113	DPC CAPABILITY REGISTER – OFFSET 2A4h (Downstream Port Only).....	111
9.3.114	DPC CONTROL REGISTER – OFFSET 2A4h (Downstream Port Only).....	111
9.3.115	DPC STATUS REGISTER – OFFSET 2A8h (Downstream Port Only).....	111
9.3.116	DPC ERROR SOURCE ID REGISTER – OFFSET 2A8h (Downstream Port Only).....	112
9.3.117	L1 PM SUBSTATES ENHANCED CAPABILITY HEADER – OFFSET 2B0h.....	112
9.3.118	L1 PM SUBSTATES CAPABILITY REGISTER – OFFSET 2B4h.....	112
9.3.119	L1 PM SUBSTATES CONTROL 1 REGISTER – OFFSET 2B8h.....	112
9.3.120	L1 PM SUBSTATES CONTROL 2 REGISTER – OFFSET 2BCh.....	112
9.3.121	VENDOR-SPECIFIC ENHANCED CAPABILITY HEADER – OFFSET 300h.....	113
9.3.122	VENDOR-SPECIFIC HEADER – OFFSET 304h.....	113
9.3.123	EEPROM CONTROL REGISTER – OFFSET 308h (Upstream Port Only).....	113
9.3.124	EEPROM ADDRESS AND DATA REGISTER – OFFSET 30Ch (Upstream Port Only).....	113
9.3.125	DEBUGOUT CONTROL REGISTER – OFFSET 310h (Port 0 Only).....	114
9.3.126	DEBUGOUT DATA REGISTER – OFFSET 314h (Port 0 Only).....	114
9.3.127	SMBUS CONTROL AND STATUS REGISTER – OFFSET 318h (Port 0 Only).....	114
9.3.128	GPIO 0-15 DIRECTION CONTROL REGISTER – OFFSET 31Ch (Port 0 Only).....	115
9.3.129	GPIO 16-31 DIRECTION CONTROL REGISTER – OFFSET 320h (Port 0 Only).....	117
9.3.130	GPIO INPUT DE-BOUNCE REGISTER – OFFSET 324h (Port 0 Only).....	119
9.3.131	GPIO 0-15 INPUT DATA REGISTER – OFFSET 328h (Port 0 Only).....	119
9.3.132	GPIO 16-31 INPUT DATA REGISTER – OFFSET 32Ch (Port 0 Only).....	120
9.3.133	GPIO 0-15 OUTPUT DATA REGISTER – OFFSET 330h (Port 0 Only).....	121
9.3.134	GPIO 16-31 OUTPUT DATA REGISTER – OFFSET 334h (Port 0 Only).....	122
9.3.135	GPIO 0-31 INTERRUPT POLARITY REGISTER – OFFSET 338h (Port 0 Only).....	123
9.3.136	GPIO 0-31 INTERRUPT STATUS REGISTER – OFFSET 33Ch (Port 0 Only).....	123
9.3.137	GPIO 0-31 INTERRUPT MASK REGISTER – OFFSET 340h (Port 0 Only).....	123
9.3.138	OPERATION MODE REGISTER – OFFSET 348h (Port 0 Only).....	124
9.3.139	CLOCK BUFFER CONTROL REGISTER – OFFSET 34Ch (Port 0 Only).....	124
9.3.140	LTSSM CSR 0 REGISTER – OFFSET 380h.....	125
9.3.141	LTSSM CSR 1 REGISTER – OFFSET 384h.....	125
9.3.142	LTSSM CSR 2 REGISTER – OFFSET 388h.....	125
9.3.143	LTSSM CSR 3 REGISTER – OFFSET 38Ch.....	126
9.3.144	LTSSM 0 REGISTER – OFFSET 390h.....	126
9.3.145	LTSSM 1 REGISTER – OFFSET 394h.....	127
9.3.146	LTSSM 2 REGISTER – OFFSET 398h.....	127
9.3.147	LTSSM 3 REGISTER – OFFSET 39Ch.....	127
9.3.148	LTSSM 4 REGISTER – OFFSET 3A0h.....	128

9.3.149	LTSSM 5 REGISTER – OFFSET 3A4h.....	128
9.3.150	LTSSM 6 REGISTER – OFFSET 3A8h.....	128
9.3.151	LTSSM 7 REGISTER – OFFSET 3ACh.....	128
9.3.152	LTSSM 8 REGISTER – OFFSET 3B0h.....	129
9.3.153	LTSSM 9 REGISTER – OFFSET 3B4h.....	130
	LTSSM.....	130
9.3.154	10 REGISTER – OFFSET 3B8h.....	130
9.3.155	LTSSM 11 REGISTER – OFFSET 3BCh.....	130
9.3.156	LTSSM 12 REGISTER – OFFSET 3C0h.....	130
9.3.157	LTSSM 13 REGISTER – OFFSET 3C4h.....	131
9.3.158	LTSSM 14 REGISTER – OFFSET 3C8h.....	131
9.3.159	LTSSM 15 REGISTER – OFFSET 3CCh.....	132
9.3.160	DLL CSR 0 REGISTER – OFFSET 420h.....	132
9.3.161	DLL CSR 1 REGISTER – OFFSET 424h.....	132
9.3.162	DLL CSR 2 REGISTER – OFFSET 428h.....	133
9.3.163	DLL CSR 3 REGISTER – OFFSET 42Ch.....	133
9.3.164	DLL CSR 4 REGISTER – OFFSET 430h.....	133
9.3.165	DLL CSR 5 REGISTER – OFFSET 434h.....	133
9.3.166	DLL CSR 6 REGISTER – OFFSET 438h.....	134
9.3.167	DLL CSR 7 REGISTER – OFFSET 43Ch.....	134
9.3.168	DLL CSR 8 REGISTER – OFFSET 440h.....	135
9.3.169	DLL CSR 9 REGISTER – OFFSET 444h.....	135
9.3.170	DLL CSR 10 REGISTER – OFFSET 448h.....	135
9.3.171	DLL CSR 11 REGISTER – OFFSET 44Ch.....	136
9.3.172	DLL CSR 12 REGISTER – OFFSET 450h.....	136
9.3.173	DLL CSR 13 REGISTER – OFFSET 454h.....	136
9.3.174	DLL CSR 14 REGISTER – OFFSET 458h.....	137
9.3.175	DLL CSR 15 REGISTER – OFFSET 45Ch.....	137
9.3.176	DLL CSR 16 REGISTER – OFFSET 460h.....	138
9.3.177	DLL CSR 17 REGISTER – OFFSET 464h.....	138
9.3.178	DLL CSR 18 REGISTER – OFFSET 468h.....	138
9.3.179	DLL CSR 19 REGISTER – OFFSET 46Ch.....	138
9.3.180	LA DEBUG REGISTER – OFFSET 470h.....	138
9.3.181	TL CSR 0 REGISTER – OFFSET 4C0h.....	138
9.3.182	TL CSR 1 REGISTER – OFFSET 4C4h.....	139
9.3.183	TL CSR 2 REGISTER – OFFSET 4C8h.....	140
9.3.184	TL CSR 3 REGISTER – OFFSET 4CCh (Port 0 Only).....	140
9.3.185	TL CSR 4 REGISTER – OFFSET 4D0h.....	140
9.3.186	DEVICE CONFIGURATION 0 REGISTER – OFFSET 504h (Port 0 Only).....	140
9.3.187	DEVICE CONFIGURATION 1 REGISTER – OFFSET 508h (Port 0 Only).....	141
9.3.188	DEVICE CONFIGURATION 2 REGISTER – OFFSET 50Ch (Port 0 Only).....	141
9.3.189	DEVICE CLOCK EXTERNAL CONTROL REGISTER – OFFSET 510h (Port 0 Only).....	142
9.3.190	DEVICE SRIS MODE EXTERNAL CONTROL REGISTER – OFFSET 514h (Port 0 Only).....	142
9.3.191	DEVICE COMM REFCLK MODE EXTERNAL CONTROL REGISTER – OFFSET 518h (Port 0 Only) 142	
9.3.192	MBIST CFG CONTROL REGISTER – OFFSET 51Ch (Port 0 Only).....	143
9.3.193	MBIST CFG STATUS REGISTER – OFFSET 520h (Port 0 Only).....	143
9.3.194	NOC BIST CONTROL REGISTER – OFFSET 524h (Port 0 Only).....	143
9.3.195	EXTERNAL LOOPBACK PRBS CONTROL REGISTER – OFFSET 528h (Port 0 Only).....	144
9.3.196	PHY SRAM PROGRAM 0 REGISER – OFFSET 52Ch (Port 0 Only).....	144
9.3.197	PHY SRAM PROGRAM 1 REGISTER – OFFSET 530h (Port 0 Only).....	145
9.3.198	FAILOVER CONTROL REGISTER – OFFSET 534h (Port 0 Only).....	145
9.3.199	THERMAL SENSOR INT MASK AND STATUS REGISTER – OFFSET 538h (Port 0 Only).....	145
9.3.200	THERMAL SENSOR CONTROL REGISTER – OFFSET 53Ch (Port 0 Only).....	145

9.3.201	DEVICE ELASTIC BUFFER EMPTY MODE EXTERNAL CONTROL REGISTER – OFFSET 540h (Port 0 Only).....	146
9.3.202	DEVICE MISC REGISTER – OFFSET 544h (Port 0 Only)	146
9.3.203	SWITCH DOMAIN MODE CONTROL REGISTER – OFFSET 558h (Port 0 Only).....	146
9.3.204	PORT CLOCK CONTROL REGISTER – OFFSET 55Ch (Port 0 Only)	147
9.3.205	PERFORMANCE COUNTER CONTROL REGISTER – OFFSET 56Ch.....	147
9.3.206	PHY SOURCE SELECT REGISTER – OFFSET 570h.....	148
9.3.207	NIC CTRL 0 REGISTER – OFFSET 5A0h (Port 0 Only)	148
9.3.208	NIC CTRL 1 REGISTER – OFFSET 5A4h (Port 0 Only)	148
9.3.209	NIC CTRL 2 REGISTER – OFFSET 5A8h (Port 0 Only)	148
9.3.210	NIC CTRL 3 REGISTER – OFFSET 5ACh (Port 0 Only).....	148
9.3.211	NIC CTRL 4 REGISTER – OFFSET 5B0h (Port 0 Only)	149
9.3.212	CR RW CTRL AND STATUS REGISTER – OFFSET 5C0h (Port 0 Only)	149
9.3.213	CR CTRL 0 REGISTER – OFFSET 5C4h (Port 0 Only).....	149
9.3.214	CR CTRL 1 REGISTER – OFFSET 5C8h (Port 0 Only).....	149
9.3.215	CR CTRL 2 REGISTER – OFFSET 5CCh (Port 0 Only).....	149
9.3.216	CR CTRL 3 REGISTER – OFFSET 5D0h (Port 0 Only)	149
9.3.217	THERMAL SENSOR TEST REGISTER – OFFSET 5D4h (Port 0 Only).....	150
9.3.218	THERMAL SENSOR CTRL 0 REGISTER – OFFSET 5D8h (Port 0 Only)	150
9.3.219	THERMAL SENSOR CTRL 1 REGISTER – OFFSET 5DCh (Port 0 Only).....	151
9.3.220	THERMAL SENSOR CTRL 2 REGISTER – OFFSET 5E0h (Port 0 Only).....	151
9.3.221	INGRESS COMPLETION TLP PACKET COUNT[31:0] REGISTER – OFFSET 600h	151
9.3.222	INGRESS COMPLETION TLP PACKET COUNT[47:32] REGISTER – OFFSET 604h	152
9.3.223	INGRESS COMPLETION TLP PAYLOAD BYTE COUNT[31:0] REGISTER – OFFSET 608h	152
9.3.224	INGRESS COMPLETION TLP PAYLOAD BYTE COUNT[47:32] REGITER – OFFSET 60Ch.....	152
9.3.225	INGRESS POST TLP PACKET COUNT[31:0] REGISTER – OFFSET 610h.....	152
9.3.226	INGRESS POST TLP PACKET COUNT[47:32] REGISTER – OFFSET 614h.....	152
9.3.227	INGRESS POST TLP PAYLOAD BYTE COUNT[31:0] REGISTER – OFFSET 618h.....	152
9.3.228	INGRESS POST TLP PAYLOAD BYTE COUNT[47:32] REGISTER – OFFSET 61Ch.....	153
9.3.229	INGRESS BAD TLP PACKET COUNT[31:0] REGISTER – OFFSET 620h.....	153
9.3.230	INGRESS NON-POST TLP PACKET COUNT[31:0] REGISTER – OFFSET 628h	153
9.3.231	INGRESS NON-POST TLP PACKET COUNT[47:32] REGISTER – OFFSET 62Ch.....	153
9.3.232	EGRESS COMPLETION TLP PACKET COUNT[31:0] REGISTER - OFFSET 630h.....	153
9.3.233	EGRESS COMPLETION TLP PACKET COUNT[47:32] REGISTER – OFFSET 634h.....	153
9.3.234	EGRESS COMPLETION TLP PAYLOAD BYTE COUNT[31:0] REGISTER – OFFSET 638h.....	154
9.3.235	EGRESS COMPLETION TLP PAYLOAD BYTE COUNT[47:32] REGISTER – OFFSET 63Ch	154
9.3.236	EGRESS POST TLP PACKET COUNT[31:0] REGISTER – OFFSET 640h	154
9.3.237	EGRESS POST TLP PACKET BYTE COUNT[47:32] REGISTER – OFFSET 644h.....	154
9.3.238	EGRESS POST TLP PAYLOAD BYTE COUNT[31:0] REGISTER – OFFSET 648h	154
9.3.239	EGRESS POST TLP PAYLOAD BYTE COUNT[47:32] REGISTER – OFFSET 64Ch.....	154
9.3.240	EGRESS ERROR TLP PACKET COUNT[15:0] REGISTER – OFFSET 650h	155
9.3.241	EGRESS ERROR TLP PAYLOAD BYTE COUNT[47:32] REGISTER – OFFSET 654h	155
9.3.242	EGRESS NON-POST TLP PACKET COUNT[31:0] REGISTER – OFFSET 658h.....	155
9.3.243	EGRESS NON-POST TLP PACKET COUNT[47:32] REGISTER – OFFSET 65Ch.....	155
9.3.244	TL/DLL/MAC/PHY ERROR TYPE SEL REGISTER – OFFSET 660h.....	155
9.3.245	TL/DLL/MAC/PHY ERROR COUNT 0 REGISTER – OFFSET 664h.....	157
9.3.246	TL/DLL/MAC/PHY ERROR COUNT 1 REGISTER – OFFSET 668h.....	157
9.3.247	TL/DLL/MAC/PHY ERROR COUNT 2 REGISTER – OFFSET 66Ch.....	157
9.3.248	TL/DLL/MAC/PHY ERROR MASK 0 REGISTER – OFFSET 670h	157
9.3.249	TL/DLL/MAC/PHY ERROR MASK 1 REGISTER – OFFSET 674h	157
9.3.250	TL/DLL/MAC/PHY ERROR MASK 2 REGISTER – OFFSET 678h.....	157
9.3.251	INGRESS ERROR COUNTER ENABLE REGISTER – OFFSET 67Ch.....	158
9.3.252	TRIGGER 1 MASK REGISTER – OFFSET 700h (Port 0 Only).....	158
9.3.253	TRIGGER 2 MASK REGISTER – OFFSET 704h (Port 0 Only).....	159
9.3.254	PATTERN 1 SETTING REGISTER – OFFSET 708h (Port 0 Only)	159

9.3.255	PATTERN 2 SETING REGISTER – OFFSET 70Ch (Port 0 Only).....	159
9.3.256	TRIGGER 1 DEBUG_OUT MODE SELECTION REGISTER – OFFSET 710h (Port 0 Only).....	159
9.3.257	TRIGGER 2 DEBUG_OUT MODE SELECTION REGISTER – OFFSET 714h (Port 0 Only).....	159
9.3.258	TRIGGER 1 AND/OR CONDITION SELECTION REGISTER – OFFSET 718h (Port 0 Only).....	159
9.3.259	TRIGGER 2 AND/OR CONDITION SELECTION REGISTER – OFFSET 71Ch (Port 0 Only).....	160
9.3.260	TRIGGER SELECT REGISTER – OFFSET 720h (Port 0 Only).....	160
9.3.261	TRIGGER POSITION SELECT REGISTER – OFFSET 724h (Port 0 Only).....	160
9.3.262	TRIGGER COUNTER SETTING REGISTER – OFFSET 72Ch (Port 0 Only).....	160
9.3.263	TRIGGER START REGISTER – OFFSET 730h (Port 0 Only).....	160
9.3.264	READ WAVEFORM DATA REGISTER – OFFSET 734h (Port 0 Only).....	160
9.3.265	SAMPLE RATE SETTING REGISTER – OFFSET 738h (Port 0 Only).....	161
9.3.266	WAVEFORM OUTPUT PORT SELECT REGISTER – OFFSET 73Ch (Port 0 Only).....	161
9.3.267	WAVEFORM READ EVENT RESET REGISTER – OFFSET 748h (Port 0 Only).....	161
9.3.268	DUMP MEMORY TO GPIO RATE CONTROL REGISTER – OFFSET 74Ch (Port 0 Only).....	161
9.3.269	DUMP WAVEFORM START REGISTER – OFFSET 750h (Port 0 Only).....	161
9.3.270	FREE RUN BUTTON REGISTER – OFFSET 754h (Port 0 Only).....	162
9.4	CDLEP CONFIGURATION REGISTERS	163
9.4.1	VENDOR ID REGISTER – OFFSET 00h.....	168
9.4.2	DEVICE ID REGISTER – OFFSET 00h.....	168
9.4.3	COMMAND REGISTER – OFFSET 04H.....	168
9.4.4	PRIMARY STATUS REGISTER – OFFSET 04H.....	169
9.4.5	REVISION REGISTER – OFFSET 08H.....	169
9.4.6	CLASS REGISTER – OFFFEST 08H.....	169
9.4.7	CACHE LINE REGISTER – OFFSET 0Ch.....	169
9.4.8	PRIMARY LATENCY TIMER REGISTER – OFFSET 0Ch.....	170
9.4.9	HEADER TYPE REGISTER – OFFSET 0Ch.....	170
9.4.10	BAR 0 REGISTER – OFFSET 10h.....	170
9.4.11	BAR 1 REGISTER – OFFSET 14h.....	170
9.4.12	BAR 2 REGISTER – OFFSET 18h.....	170
9.4.13	BAR 3 REGISTER – OFFSET 1Ch.....	171
9.4.14	BAR 4 REGISTER – OFFSET 20h.....	171
9.4.15	BAR 5 REGISTER – OFFSET 24h.....	172
9.4.16	SSVID REGISTER – OFFSET 2Ch.....	172
9.4.17	SSID REGISTER – OFFSET 2Ch.....	172
9.4.18	CAPABILITY POINTER REGISTER – OFFSET 34h.....	172
9.4.19	INTERRUPT LINE REGISTER – OFFSET 3Ch.....	173
9.4.20	INTERRUPT PIN REGISTER – OFFSET 3Ch.....	173
9.4.21	POWER MANAGEMENT CAPABILITIES REGISTER – OFFSET 40h.....	173
9.4.22	POWER MANAGEMENT DATA REGISTER – OFFSET 44h.....	173
9.4.23	PPB SUPPORT EXTENSIONS REGISTER – OFFSET 44h.....	174
9.4.24	DATA REGISTER– OFFSET 44h.....	174
9.4.25	MSI CAPABILITIES REGISTER – OFFSET 48h.....	174
9.4.26	MESSAGE ADDRESS REGISTER – OFFSET 4Ch.....	174
9.4.27	MESSAGE UPPER ADDRESS REGISTER – OFFSET 50h.....	174
9.4.28	MESSAGE DATA REGISTER – OFFSET 54h.....	174
9.4.29	MESSAGE MASK REGISTER – OFFSET 58h.....	175
9.4.30	MESSAGE PENDING REGISTER – OFFSET 5Ch.....	175
9.4.31	PCI EXPRESS CAPABILITIES REGISTER – OFFSET 68h.....	175
9.4.32	DEVICE CAPABILITIES REGISTER – OFFSET 6Ch.....	175
9.4.33	DEVICE CONTROL REGISTER – OFFSET 70h.....	176
9.4.34	DEVICE STATUS REGISTER – OFFSET 70h.....	176
9.4.35	LINK CAPABILITIES REGISTER – OFFSET 74h.....	177
9.4.36	LINK CONTROL REGISTER – OFFSET 78h.....	178
9.4.37	LINK STATUS REGISTER – OFFSET 78h.....	178
9.4.38	SLOT CAPABILITIES REGISTER – OFFSET 7Ch.....	179

9.4.39	SLOT CONTROL REGISTER – OFFSET 80h.....	179
9.4.40	SLOT STATUS REGISTER – OFFSET 80h.....	179
9.4.41	DEVICE CAPABILITIES REGISTER 2 – OFFSET 8Ch.....	179
9.4.42	DEVICE CONTROL REGISTER 2 – OFFSET 90h.....	179
9.4.43	DEVICE STATUS REGISTER 2 – OFFSET 90h.....	180
9.4.44	LINK CAPABILITIES REGISTER 2 – OFFSET 94h.....	180
9.4.45	LINK CONTROL REGISTER 2 – OFFSET 98h.....	180
9.4.46	LINK STATUS REGISTER 2 – OFFSET 98h.....	180
9.4.47	SLOT CAPABILITIES REGISTER 2 – OFFSET 9Ch.....	181
9.4.48	SLOT CONTROL REGISTER 2 – OFFSET A0h.....	181
9.4.49	SLOT STATUS REGISTER 2 – OFFSET A0h.....	181
9.4.50	SSID/SSVID CAPATILITIES REGISTER – OFFSET A4h.....	181
9.4.51	SUBSYSTEM VENDOR ID REGISTER – OFFSET A8h.....	181
9.4.52	SUBSYSTEM ID REGISTER – OFFSET A8h.....	181
9.4.53	MSI-X CAPATILITIES REGISTER – OFFSET B0h.....	182
9.4.54	MSI-X TABLE OFFSET / TABLE BIR REGISTER – OFFSET B4h.....	182
9.4.55	MSI-X PBA OFFSET / PBA BIR REGISTER – OFFSET B8h.....	182
9.4.56	VENDOR SPECIFIC CAPABILITIES REGISTER – OFFSET C8h.....	182
9.4.57	BAR 0 CONFIGURATION REGISTER – OFFSET E0h.....	182
9.4.58	BAR 0-1 CONFIGURATION REGISTER – OFFSET E4h.....	183
9.4.59	BAR 2 CONFIGURATION REGISTER – OFFSET E8h.....	183
9.4.60	BAR 2-3 CONFIGURATION REGISTER – OFFSET ECh.....	184
9.4.61	BAR 4 CONFIGURATION REGISTER – OFFSET F0h.....	184
9.4.62	BAR 4-5 CONFIGURATION REGISTER – OFFSET F4h.....	185
9.4.63	PCI EXPRESS ADVANCED ERROR REPORTING ENHANCED CAPABILITY HEADER REGISTER – OFFSET 100h.....	185
9.4.64	UNCORRECTABLE ERROR STATUS REGISTER – OFFSET 104h.....	186
9.4.65	UNCORRECTABLE ERROR MASK REGISTER – OFFSET 108h.....	186
9.4.66	UNCORRECTABLE ERROR SEVERITY REGISTER – OFFSET 10Ch.....	187
9.4.67	CORRECTABLE ERROR STATUS REGISTER – OFFSET 110h.....	188
9.4.68	CORRECTABLE ERROR MASK REGISTER – OFFSET 114h.....	188
9.4.69	ADVANCE ERROR CAPABILITIES AND CONTROL REGISTER – OFFSET 118h.....	188
9.4.70	HEADER LOG REGISTER – OFFSET From 11Ch to 128h.....	189
9.4.71	PCI EXPRESS VIRTUAL CHANNEL ENHANCED CAPABILITYHEADER REGISTER – OFFSET 130h 189	
9.4.72	PORT VC CAPABILITY REGISTER 1 – OFFSET 134h.....	189
9.4.73	PORT VC CAPABILITY REGISTER 2 – OFFSET 138h.....	189
9.4.74	PORT VC CONTROL REGISTER – OFFSET 13Ch.....	189
9.4.75	PORT VC STATUS REGISTER – OFFSET 13Ch.....	190
9.4.76	VC RESOURCE CAPABILITY REGISTER (0) – OFFSET 140h.....	190
9.4.77	VC RESOURCE CONTROL REGISTER (0)– OFFSET 144h.....	190
9.4.78	VC RESOURCE STATUS REGISTER (0) – OFFSET 148h.....	191
9.4.79	DEVICE SERIAL NUMBER ENHANCED CAPABILITY HEADER REGISTER – OFFSET 1A0h.....	191
9.4.80	DEVICE SERIAL NUMBER LOWER DW REGISTER – OFFSET 1A4h.....	191
9.4.81	DEVICE SERIAL NUMBER HIGHER DW REGISTER – OFFSET 1A8h.....	191
9.4.82	PCI EXPRESS POWER BUDGETING ENHANCED CAPABILITY HEADER REGISTER – OFFSET 1B0h 191	
9.4.83	DATA SELECT REGISTER – OFFSET 1B4h.....	191
9.4.84	POWER BUDGETING DATA REGISTER – OFFSET 1B8h.....	192
9.4.85	POWER BUDGET CAPABILITY REGISTER – OFFSET 1BCh.....	192
9.4.86	SECONDARY PCI EXPRESS EXTENDED CAPABILITY HEADER – OFFSET 210h.....	192
9.4.87	LINK CONTROL 3 REGISTER – OFFSET 214h.....	192
9.4.88	LANE ERROR STATUS REGISTER – OFFSET 218h.....	192
9.4.89	LANE EQUALIZATION CONTROL REGISTER – OFFSET 21Ch – 230h.....	193
9.4.90	LI PM SUBSTATES ENHANCED CAPABILITY HEADER – OFFSET 2B0h.....	193

9.4.91	LI PM SUBSTATES CAPABILITY REGISTER – OFFSET 2B4h.....	193
9.4.92	LI PM SUBSTATES CONTROL 1 REGISTER – OFFSET 2B8h	193
9.4.93	LI PM SUBSTATES CONTROL 2 REGISTER – OFFSET 2BCh.....	194
9.4.94	CDEP DATA 2 REGISTER – OFFSET 2E0h	194
9.4.95	VENDOR-SPECIFIC ENHANCED CAPABILITY HEADER – OFFSET 300h.....	194
9.4.96	VENDOR-SPECIFIC HEADER – OFFSET 304h.....	194
9.4.97	DEBUGOUT CONTROL REGISTER – OFFSET 310h (Port 0 Only)	194
9.4.98	DEBUGOUT DATA REGISTER – OFFSET 314h (Port 0 Only)	194
9.4.99	SMBUS CONTROL AND STATUS REGISTER – OFFSET 318h (Port 0 Only).....	195
9.4.100	GPIO 0-15 DIRECTION CONTROL REGISTER – OFFSET 31Ch (Port 0 Only).....	195
9.4.101	GPIO 16-31 DIRECTION CONTROL REGISTER – OFFSET 320h (Port 0 Only)	197
9.4.102	GPIO INPUT DE-BOUNCE REGISTER – OFFSET 324h (Port 0 Only)	199
9.4.103	GPIO 0-15 INPUT DATA REGISTER – OFFSET 328h (Port 0 Only).....	200
9.4.104	GPIO 16-31 INPUT DATA REGISTER – OFFSET 32Ch (Port 0 Only).....	201
9.4.105	GPIO 0-15 OUTPUT DATA REGISTER – OFFSET 330h (Port 0 Only).....	202
9.4.106	GPIO 16-31 OUTPUT DATA REGISTER – OFFSET 334h (Port 0 Only).....	203
9.4.107	GPIO 0-31 INTERRUPT POLARITY REGISTER – OFFSET 338h (Port 0 Only).....	204
9.4.108	GPIO 0-31 INTERRUPT STATUS REGISTER – OFFSET 33Ch (Port 0 Only).....	204
9.4.109	GPIO 0-31 INTERRUPT MASK REGISTER – OFFSET 340h (Port 0 Only).....	204
9.4.110	OPERATION MODE REGISTER – OFFSET 348h (Port 0 Only).....	204
9.4.111	CLOCK BUFFER CONTROL REGISTER – OFFSET 34Ch (Port 0 Only)	205
9.4.112	LTSSM CSR 0 REGISTER – OFFSET 380h	205
9.4.113	LTSSM CSR 1 REGISTER – OFFSET 384h	206
9.4.114	LTSSM CSR 2 REGISTER – OFFSET 388h	206
9.4.115	LTSSM CSR 3 REGISTER – OFFSET 38Ch.....	207
9.4.116	LTSSM 0 REGISTER – OFFSET 390h	207
9.4.117	LTSSM 1 REGISTER – OFFSET 394h	207
9.4.118	LTSSM 2 REGISTER – OFFSET 398h	208
9.4.119	LTSSM 3 REGISTER – OFFSET 39Ch.....	208
9.4.120	LTSSM 4 REGISTER – OFFSET 3A0h.....	208
9.4.121	LTSSM 5 REGISTER – OFFSET 3A4h.....	209
9.4.122	LTSSM 6 REGISTER – OFFSET 3A8h.....	209
9.4.123	LTSSM 7 REGISTER – OFFSET 3ACh	209
9.4.124	LTSSM 8 REGISTER – OFFSET 3B0h.....	210
9.4.125	LTSSM 9 REGISTER – OFFSET 3B4h.....	210
9.4.126	LTSSM 10 REGISTER – OFFSET 3B8h.....	211
9.4.127	LTSSM 11 REGISTER – OFFSET 3BCh	211
9.4.128	LTSSM 12 REGISTER – OFFSET 3C0h.....	211
9.4.129	LTSSM 13 REGISTER – OFFSET 3C4h.....	212
9.4.130	LTSSM 14 REGISTER – OFFSET 3C8h.....	212
9.4.131	LTSSM 15 REGISTER – OFFSET 3CCh.....	212
9.4.132	DLL CSR 0 REGISTER – OFFSET 420h.....	213
9.4.133	DLL CSR 1 REGISTER – OFFSET 424h.....	213
9.4.134	DLL CSR 2 REGISTER – OFFSET 428h.....	213
9.4.135	DLL CSR 3 REGISTER – OFFSET 42Ch.....	214
9.4.136	DLL CSR 4 REGISTER – OFFSET 430h.....	214
9.4.137	DLL CSR 5 REGISTER – OFFSET 434h.....	214
9.4.138	DLL CSR 6 REGISTER – OFFSET 438h.....	214
9.4.139	DLL CSR 7 REGISTER – OFFSET 43Ch	215
9.4.140	DLL CSR 8 REGISTER – OFFSET 440h.....	215
9.4.141	DLL CSR 9 REGISTER – OFFSET 444h.....	216
9.4.142	DLL CSR 10 REGISTER – OFFSET 448h.....	216
9.4.143	DLL CSR 11 REGISTER – OFFSET 44Ch.....	216
9.4.144	DLL CSR 12 REGISTER – OFFSET 450h.....	217
9.4.145	DLL CSR 13 REGISTER – OFFSET 454h.....	217

9.4.146	DLL CSR 14 REGISTER – OFFSET 458h.....	217
9.4.147	DLL CSR 15 REGISTER – OFFSET 45Ch.....	218
9.4.148	DLL CSR 16 REGISTER – OFFSET 460h.....	218
9.4.149	DLL CSR 17 REGISTER – OFFSET 464h.....	218
9.4.150	DLL CSR 18 REGISTER – OFFSET 468h.....	218
9.4.151	DLL CSR 19 REGISTER – OFFSET 46Ch.....	218
9.4.152	LA DEBUG REGISTER – OFFSET 470h.....	219
9.4.153	TL CSR 0 REGISTER – OFFSET 4C0h.....	219
9.4.154	TL CSR 1 REGISTER – OFFSET 4C4h.....	219
9.4.155	TL CSR 2 REGISTER – OFFSET 4C8h.....	220
9.4.156	TL CSR 3 REGISTER – OFFSET 4CCh (Port 0 Only).....	220
9.4.157	TL CSR 4 REGISTER – OFFSET 4D0h.....	221
9.4.158	DEVICE CONFIGURATION 0 REGISTER – OFFSET 504h (Port 0 Only).....	221
9.4.159	DEVICE CONFIGURATION 1 REGISTER – OFFSET 508h (Port 0 Only).....	221
9.4.160	DEVICE CONFIGURATION 2 REGISTER – OFFSET 50Ch (Port 0 Only).....	221
9.4.161	DEVICE CLOCK EXTERNAL CONTROL REGISTER – OFFSET 510h (Port 0 Only).....	222
9.4.162	DEVICE SRIS EXTERNAL CONTROL REGISTER – OFFSET 514h (Port 0 Only).....	223
9.4.163	DEVICE COMM REFCLK MODE EXTERNAL CONTROL REGISTER – OFFSET 518h (Port 0 Only) 223	
9.4.164	MBIST CFG CONTROL REGISTER – OFFSET 51Ch (Port 0 Only).....	224
9.4.165	MBIST CFG STATUS REGISTER – OFFSET 520h (Port 0 Only).....	224
9.4.166	NOC BIST CONTROL REGISTER – OFFSET 524h (Port 0 Only).....	224
9.4.167	EXTERNAL LOOPBACK PRBS CONTROL REGISTER – OFFSET 528h (Port 0 Only).....	224
9.4.168	PHY SRAM PROGRAM 0 REGISTER – OFFSET 52Ch (Port 0 Only).....	225
9.4.169	PHY SRAM PROGRAM 1 REGISTER – OFFSET 530h (Port 0 Only).....	225
9.4.170	FAILOVER CONTROL REGISTER – OFFSET 534h (Port 0 Only).....	225
9.4.171	THERMAL SENSOR INT MASK AND STATUS REGISTER – OFFSET 538h (Port 0 Only).....	226
9.4.172	THERMAL SENSOR CONTROL REGISTER – OFFSET 53Ch (Port 0 Only).....	226
9.4.173	DEVICE ELASTIC BUFFER EMPTY MODE EXTERNAL CONTROL REGISTER – OFFSET 540h (Port 0 Only).....	226
9.4.174	DEVICE MISC REGISTER – OFFSET 544h (Port 0 Only).....	227
9.4.175	SWITCH DOMAIN MODE CONTROL – OFFSET 558h (Port 0 Only).....	227
9.4.176	PORT CLOCK CONTROL REGISTER – OFFSET 55Ch (Port 0 Only).....	227
9.4.177	PERFORMANCE COUNTER CONTROL REGISTER – OFFSET 56Ch.....	228
9.4.178	PHY SOURCE SELECT REGISTER – OFFSET 570h.....	228
9.4.179	NIC CTRL 0 REGISTER – OFFSET 5A0h (Port 0 Only).....	228
9.4.180	NIC CTRL 1 REGISTER – OFFSET 5A4h (Port 0 Only).....	229
9.4.181	NIC CTRL 2 REGISTER – OFFSET 5A8h (Port 0 Only).....	229
9.4.182	NIC CTRL 3 REGISTER – OFFSET 5ACh (Port 0 Only).....	229
9.4.183	NIC CTRL 4 REGISTER – OFFSET 5B0h (Port 0 Only).....	229
9.4.184	CR RW CTRL AND STATUS REGISTER – OFFSET 5C0h (Port 0 Only).....	229
9.4.185	CR CTRL 0 REGISTER – OFFSET 5C4h (Port 0 Only).....	230
9.4.186	CR CTRL 1 REGISTER – OFFSET 5C8h (Port 0 Only).....	230
9.4.187	CR CTRL 2 REGISTER – OFFSET 5CCh (Port 0 Only).....	230
9.4.188	CR CTRL 3 REGISTER – OFFSET 5D0h (Port 0 Only).....	230
9.4.189	THERMAL SENSOR TEST REGISTER – OFFSET 5D4h (Port 0 Only).....	230
9.4.190	THERMAL SENSOR CTRL 0 REGISTER – OFFSET 5D8h (Port 0 Only).....	231
9.4.191	THERMAL SENSOR CTRL 1 REGISTER – OFFSET 5DCh (Port 0 Only).....	231
9.4.192	THERMAL SENSOR CTRL 2 REGISTER – OFFSET 5E0h (Port 0 Only).....	232
9.4.193	INGRESS COMPLETION TLP PACKET COUNT[31:0] REGISTER – OFFSET 600h.....	232
9.4.194	INGRESS COMPLETION TLP PACKET COUNT[47:32] REGISTER – OFFSET 604h.....	233
9.4.195	INGRESS COMPLETION TLP PAYLOAD BYTE COUNT[31:0] REGISTER – OFFSET 608h.....	233
9.4.196	INGRESS COMPLETION TLP PAYLOAD BYTE COUNT[47:32] REGISTER – OFFSET 60Ch.....	233
9.4.197	INGRESS POST TLP PACKET COUNT[31:0] REGISTER – OFFSET 610h.....	233
9.4.198	INGRESS POST TLP PACKET COUNT[47:32] REGISTER – OFFSET 614h.....	233

9.4.199	INGRESS POST TLP PAYLOAD BYTE COUNT[31:0] REGISTER – OFFSET 618h.....	233
9.4.200	INGRESS POST TLP PAYLOAD BYTE COUNT[47:32] REGISTER – OFFSET 61Ch.....	234
9.4.201	INGRESS BAD TLP PACKET COUNT[31:0] REGISTER – OFFSET 620h.....	234
9.4.202	INGRESS NON-POST TLP PACKET COUNT[31:0] REGISTER – OFFSET 628h.....	234
9.4.203	INGRESS NON-POST TLP PACKET COUNT[47:32] REGISTER – OFFSET 62Ch.....	234
9.4.204	EGRESS COMPLETION TLP PACKET COUNT[31:0] REGISTER – OFFSET 630h.....	234
9.4.205	EGRESS COMPLETION TLP PACKET COUNT[47:32] REGISTER – OFFSET 634h.....	234
9.4.206	EGRESS COMPLETION TLP PAYLOAD BYTE COUNT[31:0] REGISTER – OFFSET 638h.....	235
9.4.207	EGRESS COMPLETION TLP PAYLOAD BYTE COUNT[47:32] REGISTER – OFFSET 63Ch.....	235
9.4.208	EGRESS POST TLP PACKET COUNT[31:0] REGISTER – OFFSET 640h.....	235
9.4.209	EGRESS POST TLP PACKET BYTE COUNT[47:32] REGISTER – OFFSET 644h.....	235
9.4.210	EGRESS POST TLP PAYLOAD BYTE COUNT[31:0] REGISTER – OFFSET 648h.....	235
9.4.211	EGRESS POST TLP PAYLOAD BYTE COUNT[47:32] REGISTER – OFFSET 64Ch.....	235
9.4.212	EGRESS ERROR TLP PACKET COUNT[15:0] REGISTER – OFFSET 650h.....	236
9.4.213	EGRESS ERROR TLP PAYLOAD BYTE COUNT[47:32] REGISTER – OFFSET 654h.....	236
9.4.214	EGRESS NON-POST TLP PACKET COUNT[31:0] REGISTER – OFFSET 658h.....	236
9.4.215	EGRESS NON-POST TLP PACKET COUNT[47:32] REGISTER – OFFSET 65Ch.....	236
9.4.216	TL/DLL/MAC/PHY ERROR TYPE SEL REGISTER – OFFSET 660h.....	236
9.4.217	TL/DLL/MAC/PHY ERROR COUNT 0 REGISTER – OFFSET 664h.....	238
9.4.218	TL/DLL/MAC/PHY ERROR COUNT 1 REGISTER – OFFSET 668h.....	238
9.4.219	TL/DLL/MAC/PHY ERROR COUNT 2 REGISTER – OFFSET 66Ch.....	238
9.4.220	TL/DLL/MAC/PHY ERROR MASK 0 REGISTER – OFFSET 670h.....	238
9.4.221	TL/DLL/MAC/PHY ERROR MASK 1 REGISTER – OFFSET 674h.....	239
9.4.222	TL/DLL/MAC/PHY ERROR MASK 2 REGISTER – OFFSET 678h.....	239
9.4.223	INGRESS ERROR COUNTER ENABLE REGISTER – OFFSET 67Ch.....	239
9.4.224	TRIGGER 1 MASK REGISTER – OFFSET 700h (Port 0 Only).....	240
9.4.225	TRIGGER 2 MASK REGISTER – OFFSET 704h (Port 0 Only).....	240
9.4.226	PATTERN 1 SETTING REGISTER – OFFSET 708h (Port 0 Only).....	240
9.4.227	PATTERN 2 SETTING REGISTER – OFFSET 70Ch (Port 0 Only).....	240
9.4.228	TRIGGER 1 DEBUG_OUT MODE SELECTION REGISTER – OFFSET 710h (Port 0 Only).....	240
9.4.229	TRIGGER 2 DEBUG_OUT MODE SELECTION REGISTER – OFFSET 714h (Port 0 Only).....	240
9.4.230	TRIGGER 1 AND/OR CONDITION SELECTION REGISTER – OFFSET 718h (Port 0 Only).....	241
9.4.231	TRIGGER 2 AND/OR CONDITION SELECTION REGISTER – OFFSET 71Ch (Port 0 Only).....	241
9.4.232	TRIGGER SELECT REGISTER – OFFSET 720h (Port 0 Only).....	241
9.4.233	TRIGGER POSITION SELECTION REGISTER – OFFSET 724h (Port 0 Only).....	241
9.4.234	TRIGGER COUNTER SETTING REGISTER – OFFSET 72Ch (Port 0 Only).....	241
9.4.235	TRIGGER START REGISTER – OFFSET 730h (Port 0 Only).....	241
9.4.236	READ WAVEFORM DATA REGISTER – OFFSET 734h (Port 0 Only).....	242
9.4.237	SAMPLE RATE SETTING REGISTER – OFFSET 738h (Port 0 Only).....	242
9.4.238	WAVEFORM OUTPUT PORT SELECT REGISTER – OFFSET 73Ch (Port 0 Only).....	242
9.4.239	WAVEFORM READ EVENT RESET REGISTER – OFFSET 748h (Port 0 Only).....	242
9.4.240	DUMP MEMORY TO GPIO RATE CONTROL REGISTER – OFFSET 74Ch (Port 0 Only).....	243
9.4.241	DUMP WAVEFORM START REGISTER – OFFSET 750h (Port 0 Only).....	243
9.4.242	FREE RUN BUTTON REGISTER – OFFSET 754h (Port 0 Only).....	243
9.4.243	VENDOR SPECIFIC CAPABILITIES REGISTER – OFFSET 900h.....	243
9.4.244	VENDOR SPECIFIC HEADER REGISTER – OFFSET 904h.....	243
9.4.245	BTR 2 REGISTER – OFFSET 908h.....	243
9.4.246	BTR 3 REGISTER – OFFSET 90Ch.....	244
9.4.247	BTR 4 REGISTER – OFFSET 910h.....	244
9.4.248	BTR 5 REGISTER – OFFSET 914h.....	244
9.4.249	ADDRESS LUT ACCESS ADDRESS REGISTER – OFFSET 918h.....	244
9.4.250	ADDRESS LUT ACCESS DATA 0 REGISTER – OFFSET 91Ch.....	245
9.4.251	ADDRESS LUT ACCESS DATA 1 REGISTER – OFFSET 920h.....	245
9.4.252	REQ ID/DOMAIN LUT 0 – 15– OFFSET 924h to 960h.....	245
9.4.253	CAPTURED BUS ID for DOMAIN 0 to 1 – OFFSET 994h.....	245

9.4.254	DOOR BELL IRQ SET REGISTER – OFFSET 9C4h.....	246
9.4.255	DOOR BELL IRQ CLEAR REGISTER – OFFSET 9C8h.....	246
9.4.256	DOOR BELL IRQ MASK SET REGISTER – OFFSET 9CCh.....	246
9.4.257	DOOR BELL IRQ MASK CLEAR REGISTER – OFFSET 9D0h.....	246
9.4.258	SCRATCHPAD 0 REGISTER – OFFSET 9E4h.....	246
9.4.259	SCRATCHPAD 1 REGISTER – OFFSET 9E8h.....	247
9.4.260	SCRATCHPAD 2 REGISTER – OFFSET 9ECh.....	247
9.4.261	SCRATCHPAD 3 REGISTER – OFFSET 9F0h.....	247
9.4.262	SCRATCHPAD 4 REGISTER – OFFSET 9F4h.....	247
9.4.263	SCRATCHPAD 5 REGISTER – OFFSET 9F8h.....	247
9.4.264	SCRATCHPAD 6 REGISTER – OFFSET 9FCh.....	247
9.4.265	SCRATCHPAD 7 REGISTER – OFFSET A00h.....	247
9.4.266	CDEP DATA 0 REGISTER – OFFSET A04h.....	247
9.4.267	CDEP DATA 1 REGISTER – OFFSET A08h.....	248
9.4.268	SQ/CQ POINTER CONTROL AND STATUS REGISTER – OFFSET A0Ch.....	248
9.4.269	SQ TAIL BASE POINTER [31:0] REGISTER – OFFSET A10h.....	248
9.4.270	SQ TAIL BASE POINTER [63:32] REGISTER – OFFSET A14h.....	248
9.4.271	CQ HEADER LOCATION[31:0] REGISTER – OFFSET A18h.....	249
9.4.272	CQ HEADER LOCATION[63:32] REGISTER – OFFSET A1Ch.....	249
9.4.273	UNCORRECTABLE FATAL ERROR LINK RESET REGISTER – OFFSET A28h.....	249
9.4.274	SYNC. CDVEP UNCORRECTABLE ERROR STATUS REGISTER – OFFSET A2Ch.....	249
9.4.275	Source ID LUT 0 – 7 – OFFSET A80h to A9Ch.....	250
9.5	CDVEP CONFIGURATION REGISTERS.....	252
9.5.1	VENDOR ID REGISTER – OFFSET 00h.....	253
9.5.2	DEVICE ID REGISTER – OFFSET 00h.....	253
9.5.3	COMMAND REGISTER – OFFSET 04h.....	253
9.5.4	PRIMARY STATUS REGISTER – OFFSET 04h.....	254
9.5.5	REVISION ID REGISTER – OFFSET 08h.....	255
9.5.6	CLASS REGISTER – OFFSET 08h.....	255
9.5.7	CACHE LINE REGISTER – OFFSET 0Ch.....	255
9.5.8	PRIMARY LATENCY TIMER REGISTER – OFFSET 0Ch.....	255
9.5.9	HEADER TYPE REGISTER – OFFSET 0Ch.....	255
9.5.10	BAR 0 REGISTER – OFFSET 10h.....	255
9.5.11	BAR 1 REGISTER – OFFSET 14h.....	256
9.5.12	BAR 2 REGISTER – OFFSET 18h.....	256
9.5.13	BAR 3 REGISTER – OFFSET 1Ch.....	256
9.5.14	BAR 4 REGISTER – OFFSET 20h.....	257
9.5.15	BAR 5 REGISTER – OFFSET 24h.....	257
	SSVID.....	257
9.5.16	REGISTER – OFFSET 2Ch.....	257
9.5.17	SSID REGISTER – OFFSET 2Ch.....	258
9.5.18	CAPABILITY POINTER REGITER – OFFSET 34h.....	258
9.5.19	INTERRUPT LINE REGISTER – OFFSET 3Ch.....	258
9.5.20	INTERRUPT PIN REGISTER – OFFSET 3Ch.....	258
9.5.21	POWER MANAGEMENT CAPABILITIES REGISTER – OFFSET 40h.....	258
	POWER.....	258
9.5.22	MANAGEMENT DATA REGISTER – OFFSET 44h.....	258
9.5.23	PPB SUPPORT EXTENSIONS REGISTER – OFFSET 44h.....	259
9.5.24	DATA REGISTER – OFFSET 44h.....	259
9.5.25	MSI CAPABILITIES REGISTER – OFFSET 48h.....	259
9.5.26	MESSAGE ADDRESS REGISTER – OFFSET 4Ch.....	259
9.5.27	MESSAGE UPPER ADDRESS REGISTER – OFFSET 50h.....	259
9.5.28	MESSAGE DATA REGISTER – OFFSET 54h.....	260
9.5.29	MESSAGE MASK REGISTER – OFFSET 58h.....	260
9.5.30	MESSAGE PENDING REGISTER – OFFSET 5Ch.....	260

9.5.31	PCI EXPRESS CAPABILITIES REGISTER – OFFSET 68h	260
9.5.32	DEVICE CAPABILITIES REGISTER – OFFSET 6Ch	260
9.5.33	DEVICE CONTROL REGISTER – OFFSET 70h	261
9.5.34	DEVICE STATUS REGISTER – OFFSET 70h	262
9.5.35	LINK CAPABILITIES REGISTER – OFFSET 74h	262
9.5.36	LINK CONTROL REGISTER – OFFSET 78h	263
9.5.37	LINK STATUS REGISTER – OFFSET 78h	263
9.5.38	SLOT CAPABILITIES REGISTER – OFFSET 7Ch	264
9.5.39	SLOT CONTROL REGISTER – OFFSET 80h	264
9.5.40	SLOT STATUS REGISTER – OFFSET 80h	264
9.5.41	DEVICE CAPABILITIES REGISTER 2 – OFFSET 8Ch	264
9.5.42	DEVICE CONTROL REGISTER 2 – OFFSET 90h	264
9.5.43	DEVICE STATUS REGISTER 2 – OFFSET 90h	264
9.5.44	LINK CAPABILITIES REGISTER 2 – OFFSET 94h	264
9.5.45	LINK CONTROL REGISTER 2 – OFFSET 98h	265
9.5.46	LINK STATUS REGISTER 2 – OFFSET 98h	265
9.5.47	SLOT CAPABILITIES REGISTER 2 – OFFSET 9Ch	266
9.5.48	SLOT CONTROL REGISTER 2 – OFFSET A0h	266
9.5.49	SLOT STATUS REGISTER 2 – OFFSET A0h	266
9.5.50	SSID/SSVID CAPATILITIES REGISTER – OFFSET A4h	266
9.5.51	SUBSYSTEM VENDOR ID REGISTER – OFFSET A8h	266
9.5.52	SUBSYSTEM ID REGISTER – OFFSET A8h	266
9.5.53	MSI-X CAPATILITIES REGISTER – OFFSET B0h	266
9.5.54	MSI-X TABLE OFFSET / TABLE BIR REGSITER – OFFSET B4h	267
9.5.55	MSI-X PBA OFFSET / PBA BIR REGISTER – OFFSET B8h	267
9.5.56	VENDOR SPECIFIC CAPABILITY REGISTER – OFFSET C8h	267
9.5.57	BAR 0-1 CONFIGURATION REGISTER – OFFSET E4h	267
9.5.58	BAR 2 CONFIGURATION REGISTER – OFFSET E8h	267
9.5.59	BAR 2-3 CONFIGURATION REGISTER – OFFSET ECh	268
9.5.60	BAR 4 CONFIGURATION REGISTER – OFFSET F0h	268
9.5.61	BAR 4-5 CONFIGURATION REGISTER – OFFSET F4h	269
9.5.62	DEVICE SERIAL NUMBER ENHANCED CAPABILITY HEADER REGISTER – OFFSET 100h	269
9.5.63	DEVICE SERIAL NUMBER LOWER DW REGISTER – OFFSET 104h	269
9.5.64	DEVICE SERIAL NUMBER HIGHTER DW REGISTER – OFFSET 108h	270
9.5.65	OPERATION MODE REGISTER – OFFSET 348h (Port 0 Only)	270
9.5.66	TL CSR 0 REGISTER – OFFSET 4C0h	271
9.5.67	VENDOR SPECIFIC CAPABILITIES REGISTER – OFFSET 900h	271
9.5.68	VENDOR SPECIFIC HEADER REGISTER – OFFSET 904h	271
9.5.69	BTR 2 REGISTER – OFFSET 908h	271
9.5.70	BTR 3 REGISTER – OFFSET 90Ch	271
9.5.71	BTR 4 REGISTER – OFFSET 910h	272
9.5.72	BTR 5 REGISTER – OFFSET 914h	272
9.5.73	ADDRESS LUT ACCESS ADDRESS REGISTER – OFFSET 918h	272
9.5.74	ADDRESS LUT ACCESS DATA 0 REGISTER – OFFSET 91Ch	272
9.5.75	ADDRESS LUT ACCESS DATA 1 REGISTER – OFFSET 920h	272
9.5.76	ID/DOMAIN LUT 0 – 15– OFFSET 924h to 960h	273
9.5.77	CAPTURED BUS ID FOR DOMAIN 0 to 1 – OFFSTE 994h	273
9.5.78	DOOR BELL IRQ SET REGISTER – OFFSET 9C4h	273
9.5.79	DOOR BELL IRQ CLEAR REGISTER – OFFSET 9C8h	273
	DOOR	274
9.5.80	BELL IRQ MASK SET REGISTER – OFFSET 9CCh	274
9.5.81	DOOR BELL IRQ MASK CLEAR REGISTER – OFFSET 9D0h	274
9.5.82	SCRATCHPAD 0 REGISTER – OFFSET 9E4h	274
9.5.83	SCRATCHPAD 1 REGISTER – OFFSET 9E8h	274
9.5.84	SCRATCHPAD 2 REGISTER – OFFSET 9ECh	274

9.5.85	SCRATCHPAD 3 REGISTER – OFFSET 9F0h.....	274
9.5.86	SCRATCHPAD 4 REGISTER – OFFSET 9F4h.....	274
9.5.87	SCRATCHPAD 5 REGISTER – OFFSET 9F8h.....	274
9.5.88	SCRATCHPAD 6 REGISTER – OFFSET 9FCh.....	275
9.5.89	SCRATCHPAD 7 REGISTER – OFFSET A00h.....	275
9.5.90	CDEP DATA 0 REGISTER – OFFSET A04h.....	275
9.5.91	CDEP DATA1 REGISTER – OFFSET A08h.....	275
9.6	DMA ENGINE CONFIGURATION REGISTERS (FUNC1 OR FUNC2).....	276
9.6.1	VENDOR ID REGISTER – OFFSET 00h.....	277
9.6.2	DEVICE ID REGISTER – OFFSET 00h.....	277
9.6.3	COMMAND REGISTER – OFFSET 04h.....	277
9.6.4	PRIMARY STATUS REGISTER – OFFSET 04h.....	277
9.6.5	REVISION ID REGISTER – OFFSET 08h.....	278
9.6.6	CLASS CODE REGISTER – OFFSET 08h.....	278
9.6.7	CACHE LINE REGISTER – OFFSET 0Ch.....	278
9.6.8	PRIMARY LATENCY TIMER REGISTER – OFFSET 0Ch.....	278
9.6.9	HEADER TYPE REGISTER – OFFSET 0Ch.....	279
9.6.10	BAR 0 REGISTER – OFFSET 10h.....	279
9.6.11	BAR 1 REGISTER – OFFSET 14h.....	279
9.6.12	SUBSYSTEM VENDOR ID REGISTER – OFFSET 2Ch.....	279
9.6.13	SUBSYSTEM ID REGISTER – OFFSET 2Ch.....	279
9.6.14	CAPABILITY POINTER REGISTER – OFFSET 34h.....	279
9.6.15	INTERRUPT LINE REGISTER – OFFSET 3Ch.....	279
9.6.16	INTERRUPT PIN REGISTER – OFFSET 3Ch.....	280
9.6.17	POWER MANAGEMENT CAPABILITIES REGISTER – OFFSET 40h.....	280
9.6.18	POWER MANAGEMENT DATA REGISTER – OFFSET 44h.....	280
9.6.19	PPB SUPPORT EXTENSIONS – OFFSET 44h.....	280
9.6.20	DATA REGISTER – OFFSET 44h.....	281
9.6.21	MSI CAPABILITIES REGISTER – OFFSET 48h.....	281
9.6.22	MESSAGE ADDRESS REGISTER – OFFSET 4Ch.....	281
9.6.23	MESSAGE UPPER ADDRESS REGISTER – OFFSET 50h.....	281
9.6.24	MESSAGE DATA REGISTER – OFFSET 54h.....	281
9.6.25	MESSAGE MASK REGISTER – OFFSET 58h.....	282
9.6.26	MESSAGE PENDING REGISTER – OFFSET 5Ch.....	282
9.6.27	PCI EXPRESS CAPABILITIES REGISTER – OFFSET 68h.....	282
9.6.28	DEVICE CAPABILITIES REGISTER – OFFSET 6Ch.....	282
9.6.29	DEVICE CONTROL REGISTER – OFFSET 70h.....	283
9.6.30	DEVICE STATUS REGISTER – OFFSET 70h.....	283
9.6.31	LINK CAPABILITIES REGISTER – OFFSET 74h.....	284
9.6.32	LINK CONTROL REGISTER – OFFSET 78h.....	284
9.6.33	LINK STATUS REGISTER – OFFSET 78h.....	285
9.6.34	DEVICE CAPABILITIES REGISTER 2 – OFFSET 8Ch.....	285
9.6.35	DEVICE CONTROL and STATUS REGISTER 2 – OFFSET 90h.....	286
9.6.36	LINK CAPABILITY REGISTER 2 – OFFSET 94h.....	286
9.6.37	LINK CONTROL REGISTER 2 – OFFSET 98h.....	286
9.6.38	LINK STATUS REGISTER 2 – OFFSET 98h.....	287
9.6.39	SSID/SSVID CAPABILITIES REGISTER – OFFSET A4h.....	287
9.6.40	SUBSYSTEM VENDOR ID REGISTER – OFFSET A8h.....	287
9.6.41	SUBSYSTEM ID REGISTER – OFFSET A8h.....	287
9.6.42	PCI EXPRESS ADVANCED ERROR REPORTING ENHANCED CAPABILITY HEADER REGISTER – OFFSET 100h.....	287
9.6.43	UNCORRECTABLE ERROR STATUS REGISTER – OFFSET 104h.....	287
9.6.44	UNCORRECTABLE ERROR MASK REGISTER – OFFSET 108h.....	288
9.6.45	UNCORRECTABLE ERROR SEVERITY REGISTER – OFFSET 10Ch.....	289
9.6.46	CORRECTABLE ERROR STATUS REGISTER – OFFSET 110h.....	290

9.6.47	CORRECTABLE ERROR MASK REGISTER – OFFSET 114h.....	290
9.6.48	ADVANCE ERROR CAPABILITIES AND CONTROL REGISTER – OFFSET 118h.....	290
9.6.49	HEADER LOG REGISTER – OFFSET From 11Ch to 128h.....	291
9.7	DMA ENGINE INTERFACE REGISTERS.....	292
9.7.1	DMA CONTROL AND STATUS REGISTER 0 – OFFSET 00h.....	293
9.7.2	DESCRIPTOR OWNERSHIP REGISTER 0 – OFFSET 04h.....	293
9.7.3	DESCRIPTOR OWNERSHIP REGISTER1 – OFFSET 08h.....	294
9.7.4	CHANNELDESCRIPTOR RING BASE POINTER (LOW 32-bit)REGISTER – OFFSET 0Ch.....	294
9.7.5	CHANNELDESCRIPTOR RING BASE POINTER (HIGH 32-bit) REGISTER – OFFSET 10h.....	294
9.7.6	CHANNEL DESCRIPTOR CURRENT POINTER REGISTER – OFFSET 14h.....	294
9.7.7	CHANNEL TRANSFER COUNT STATUS OF CURRENT DESCRIPTOR POINTER REGISTER – OFFSET 18h.....	294
9.7.8	CHANNEL GAP TIME CONTROL REGISTER – OFFSET 1Ch.....	294
9.7.9	DMA CONTROL AND STATUS REGISTER 1 – OFFSET 20h.....	295
9.7.10	CHANNEL DESCRIPTOR RING SIZE FORPREFETCH – OFFSET 24h.....	296
9.7.11	DOMAIN 0/1/2/3 MAX PAYLOAD SIZE AND READ REQUEST SIZE– OFFSET 28h (Global).....	296
9.7.12	DOMAIN 4/5/6/7 MAX PAYLOAD SIZE AND READ REQUEST SIZE – OFFSET 2Ch (Global).....	297
9.7.13	DOMAIN 8/9/10/11 MAX PAYLOAD SIZE AND READ REQUEST SIZE – OFFSET 30h (Global)....	297
9.7.14	DOMAIN 0/1/2/3 BUS NUMBER – OFFSET 34h (Global).....	298
9.7.15	DOMAIN 4/5/6/7 BUS NUMBER – OFFSET 38h (Global).....	298
9.7.16	DOMAIN 8/9/10/11 BUS NUMBER – OFFSET 3Ch (Global).....	299
9.7.17	USER DEFINED ATTRIBUTES FOR DMA OPERATION – OFFSET 40h.....	299
9.7.18	CHANNEL UNCORRETABLE EEEOR STATUS– OFFSET 44h.....	299
9.7.19	DMA READ THRESHOLD CONTROL – OFFSET 5Ch.....	300
9.7.20	DMA HARDWARE CONTROL – OFFSET 88h (Global).....	300
9.7.21	DMA HARDWARE STATUS – OFFSET 8Ch (Global).....	300
10	POWER SEQUENCE.....	301
11	IEEE 1149.1 COMPATIBLE JTAG CONTROLLER.....	302
11.1	INSTRUCTION REGISTER.....	302
11.2	BYPASS REGISTER.....	302
11.3	DEVICE ID REGISTER.....	302
11.4	BOUNDARY SCAN REGISTER.....	303
11.5	JTAG BOUNDARY SCAN REGISTER ORDER.....	303
12	ELECTRICAL AND TIMING SPECIFICATIONS.....	307
12.1	ABSOLUTE MAXIMUM RATINGS.....	307
12.2	DC ELECTRICAL CHARACTERISTICS.....	307
12.3	PCIE REFERENCE CLOCK REQUIREMENTS.....	307
12.4	INTEGRATED CLOCK BUFFER SPECIFICATIONS.....	308
12.5	COMMON TRANSMITTER PARAMETERS.....	308
12.6	COMMON RECEIVER PARAMETERS.....	312
12.7	POWER CONSUMPTION.....	316
13	THERMAL DATA.....	317
14	PACKAGE INFORMATION.....	318
15	ORDERING INFORMATION.....	319

LIST OF TABLES

TABLE 4-1 TRANSMITTER PRESET ENCODING	36
TABLE 4-2 SUMMARY OF PCI EXPRESS ORDERING RULES	39
TABLE 5-1 MODE SELECTION	41
TABLE 5-2 LANE MAPPING	41
TABLE 5-3 PORT NUMBERING	42
TABLE 5-4 PORT-LANE MAPPING	42
TABLE 5-5 REFCLKP/N[2:0] CONNECTIONS WHEN BASE MODE IS CHOSEN	43
TABLE 5-6 REFCLKP/N[2:0] CONNECTIONS WHEN CDSR MODE IS CHOSEN	43
TABLE 5-7 CONNECTION MAP FOR REFCLKOP/N[7:0]	43
TABLE 5-8 OUTPUT CONTROL FOR REFCLKOP/N[7:0]	44
TABLE 5-9 EEPROM SPACE ADDRESS MAP	45
TABLE 5-10 SMBUS ADDRESS PIN CONFIGURATION	46
TABLE 5-11 BYTES FOR SMBUS BLOCK WRITE	47
TABLE 5-12 SAMPLE SMBUS BLOCK WRITE BYTE SEQUENCE	47
TABLE 5-13 BYTES FOR SMBUS BLOCK READ	48
TABLE 5-14 SMBUS BLOCK WRITE PORTION	49
TABLE 5-15 SMBUS BLOCK READ PORTION	50
TABLE 5-16 SMBUS READ COMMAND FOLLOWING REPEAT START FROM MASTER	50
TABLE 5-17 SMBUS RETURN BYTES	50
TABLE 5-18 SMBUS RETURN BYTES	50
TABLE 5-19 I ² C ADDRESS PIN CONFIGURATION	51
TABLE 5-20 I2C REGISTER WRITE ACCESS	52
TABLE 5-21 I2C COMMAND FORMAT FOR WRITE ACCESS	52
TABLE 5-22 I ² C COMMAND FORMAT FOR READ ACCESS	54
TABLE 6-1 CPLD SIGNAL NAME MAPPING FOR 8-BIT IO EXPANDER	58
TABLE 6-2 PORT/ADDRESS MAPPING FOR 8-BIT IO EXPANDER	58
TABLE 6-3 CPLD SIGNAL NAME MAPPING FOR 16-BIT IO EXPANDER	59
TABLE 6-4 PORT/ADDRESS MAPPING FOR 16-BIT IO EXPANDER	59
TABLE 7-1 CDEP MODE CONFIGURATION	62
TABLE 8-1 DMA MODE DEFINITION	66
TABLE 8-2 DMA FUNCTION DEFINITION IN P0 AND CDLEP UNDER VARIOUS MODES	66
TABLE 8-3 BIT DEFINITION IN CTRL FIELD OF THE 1 ST DW	70
TABLE 9-1 REGISTER TYPES	74
TABLE 9-2 LANE EQUALIZATION CONTROL REGISTER LOCATIONS	110
TABLE 9-3 LANE EQUALIZATION CONTROL REGISTER DEFINITIONS	110
TABLE 9-4: LANE EQUALIZATION CONTROL REGISTER LOCATIONS	193
TABLE 9-5: LANE EQUALIZATION CONTROL REGISTER DEFINITIONS	193
TABLE 9-6: 16-BIT REQ ID/DOMAIN LUT ENTRY 0-63 REGISTER LOCATIONS	245
TABLE 9-7: 16-BIT REQ ID/DOMAIN LUT ENTRY_N (N=0 THROUGH 15)	245
TABLE 9-8 5-BIT SYNTHESIZED ID LUT ENTRY 0-15 REGISTER LOCATIONS	250
TABLE 9-9 5-BIT SOURCE ID LUT ENTRY_N (N=0 THROUGH 7)	251
TABLE 9-10: 16-BIT ID/DOMAIN LUT ENTRY 0-15 REGISTER LOCATIONS	273
TABLE 9-11: 16-BIT ID/DOMAIN LUT ENTRY_N (N=0 THROUGH 15)	273
TABLE 9-12: DMA BASE ADDRESS IN MEMORY MODE WHEN DMA CHANNELS PERTAINING TO THE SAME HOST DOMAIN	292
TABLE 9-13: DMA BASE ADDRESS IN MEMORY MODE WHEN DMA CHANNELS PERTAINING TO DIFFERENT HOST DOMAIN	292
TABLE 11-1 INSTRUCTION REGISTER CODES	302
TABLE 11-2 JTAG DEVICE ID REGISTER	302
TABLE 11-3 JTAG BOUNDARY SCAN REGISTER DEFINITION	303
TABLE 12-1 ABSOLUTE MAXIMUM RATINGS	307
TABLE 12-2 DC ELECTRICAL CHARACTERISTICS	307
TABLE 12-3 PCIe REFERENCE CLOCK REQUIREMENT	307

TABLE 12-4 INTEGRATED CLOCK BUFFER INPUT ELECTRICAL CHARACTERISTICS.....	308
TABLE 12-5 INTEGRATED CLOCK BUFFER OUTPUT ELECTRICAL CHARACTERISTICS	308
TABLE 12-6 TRANSMITTER SPECIFICATIONS	308
TABLE 12-7 8.0 GT/S SPECIFIC TX VOLTAGE AND JITTER PARAMETERS.....	311
TABLE 12-8 RECEIVER SPECIFICATIONS	312
TABLE 12-9 5.0 GT/S TOLERANCING LIMITS FOR COMMON REFCLK RX ARCHITECTURE	314
TABLE 12-10 5.0 GT/S TOLERANCING LIMITS FOR DATA CLOCKED RX ARCHITECTURE	314
TABLE 12-11 STRESSED VOLTAGE EYE PARAMETERS.....	314
TABLE 12-12 STRESSED JITTER EYE PARAMETERS.....	315
TABLE 12-13 POWER CONSUMPTION	316
TABLE 13-1 SAMPLE SIMULATION THERMAL DATA.....	317

LIST OF FIGURES

FIGURE 3-1 PI7C9X3G816GP BALL ASSIGNMENT	34
FIGURE 4-1 BASE MODE (FAN-OUT MODE) OVERVIEW	35
FIGURE 4-2 CROSS-DOMAIN END-POINT MODE OVERVIEW	35
FIGURE 5-1 SMBUS ARCHITECTURE IMPLEMENTATION	45
FIGURE 5-2 SMBUS BLOCK WRITE COMMAND FORMAT, TO WRITE TO A SWITCH REGISTER WITHOUT PEC	46
FIGURE 5-3 SMBUS BLOCK WRITE COMMAND FORMAT, TO WRITE TO A SWITCH REGISTER WITH PEC	46
FIGURE 5-4 SMBUS BLOCK WRITE TO SET UP READ, AND RESULTING READ THAT RETURNS CFG REGISTER VALUE....	48
FIGURE 5-5 CSR READ OPERATION USING SMBUS BLOCK READ – BLOCK WRITE PROCESS CALL	50
FIGURE 5-6 CSR READ OPERATION USING SMBUS BLOCK READ – BLOCK WRITE PROCESS CALL WITH PEC	51
FIGURE 5-7 STANDARD DEVICES TO I2C BUS CONNECTION BLOCK DIAGRAM	51
FIGURE 5-8 I2C WRITE PACKET	53
FIGURE 5-9 I2C REGISTER WRITE ACCESS EXAMPLE.....	53
FIGURE 5-10 I2C WRITE COMMAND PACKET.....	53
FIGURE 5-11 I2C READ COMMAND PACKET.....	55
FIGURE 5-12 I2C REGISTER READ ACCESS EXAMPLE	55
FIGURE 5-13 I2C READ COMMAND PACKET.....	56
FIGURE 6-1 TIMING SEQUENCE FOR SURPRISED HOT PLUG OPERATION.....	60
FIGURE 7-1 SWITCH REFERENCE MODEL USED IN THE FAIL-OVER USE CASE	61
FIGURE 7-2 SWITCH REFERENCE MODEL USED IN THE CO-PROCESSOR USE CASE	62
FIGURE 8-1 DMA DESCRIPTOR MAP	68
FIGURE 8-2 DMA DESCRIPTOR LAYOUT IN AN 8-DW BLOCK	70
FIGURE 10-1 INITIAL POWER-UP SEQUENCE	301
FIGURE 14-1 PACKAGE OF DRAWING	318
FIGURE 14-2 PART MARKING	318

Abbreviations of Terms Table

Abbreviations	Explanation
ACS	Access Control Service
ARI	Alternate Routing ID
AT	Address Translation
CDEP	Cross-Domain End-Device
CR	Control Register
DMA	Direct Memory Access
PPB	PCI-to-PCI Bridge
SRIS	Separate Reference Independence SSC
SRNS	Separate Reference No SSC

1 INTRODUCTION

The PI7C9X3G816GP is a PCIe GEN3 packet switch that supports 16 lanes of GEN3 SERDES in flexible 2-port, 3-port, 4-port, 5-port and 8-port configurations. The architecture of the PCIe packet switch allows the flexible port configuration by allocating variable lane widths for each port. The packet switch can be configured to have different port types such as upstream port, downstream ports and Cross-Domain End-Point (CDEP) ports to support various applications, which include port fan-out, dual-host connectivity. Inside the packet switch, multiple DMA channels are embedded to facilitate data communication more efficiently among host(s) and end-points.

In addition, the PI7C9X3G816GP offers some extra benefits such as “maintaining high signal integrity in stress channel”, “advanced power management mechanism”, “enhanced reliability, availability and serviceability (RAS)” and “Surprised Hot Plug with LED Enclosure Management”.

1.1 KEY FEATURES

- Port and Lane Configurations for 8-port/16-Lane PCI Express GEN3 packet switch
 - Configurable Upstream lane widths of x1, x2, x4 or x8
 - Configurable Downstream port number up to 7
 - Configurable Downstream lane widths of x1, x2, x4 or x8
- Reference Clock Management
 - Integrated PCIe Gen3 clock buffer for all downstream ports
 - Support three reference clock structures (Common, SRNS and SRIS)
 - Handle SSC Isolation up to one port
 - Provide two clock application modes (Base and CDSR)
- Power Management
 - Support 7 power states (P0/P0s/P1/P1.1/P1.2/P2/P1.2PG)
 - Start-up power management scheme
 - “Empty” Hot-Plug ports put in P2 state
 - Continuous power management scheme
 - Support ASPM L1 Sub-state (P1.1/P1.2)
 - Support Message packet for System Power Management
 - Latency Tolerance Reporting (LTR)
 - Optimized Buffer Flush Fill (OBFF)
- PHY and MAC Layers
 - PHY initial settings optionally programmable through JTAG, EEPROM, and SMBus/I²C
 - Adaptive Continuous Time Linear Equalizer and 5-tap Decision Feedback Equalizer for RX
 - Adaptive and programmable 3-tap TX equalization
 - RX Polarity Inversion and Lane Reversal
- Data Link Layer
 - Programmable ACK latency timer to respond ACK based upon traffic condition
 - Configurable Flow Control Credit to balance bandwidth utilization and buffer usage
- Transaction Layer
 - Packet forwarding options including Cut-Through and Store & Forward
 - Support up to 512-Byte Max Payload Size
 - Low packet forwarding latency < 150ns (typical case)
 - Access Control Service (ACS) for peer-to-peer traffic
 - Address Translation (AT) packet for SR-IOV application
 - Support Atomic operation
 - Support Multicast
 - Provide Performance Visibility for ingress/egress packet types and packet counts
- Dual-Host Application
 - Support one Cross-Domain End-Point (CDEP) port for Host-to-Host Communications
 - Support Fail-over using CDEP port
 - Provide up to 4 physical or 8 virtual DMA channels enabling communications among Hosts and EPs
- Reliability, Availability and Serviceability
 - Enhanced Advanced Error Reporting
 - End-to-End Data Protection with ECC
 - Error Handling Mechanism
 - Support Surprise Hot Removal
 - Support Downstream Port Containment (DPC)
 - Support Hot Plug for Upstream and Downstream port
 - Provide Serial and Parallel Hot Plug Types
 - Support LED Management
 - Thermal Sensor reporting operational temperature instantly
 - IEEE 1149.1 and 1149.6 JTAG interface support
- Advanced Diagnostic Tools

- PHY Eye[™]
- MAC Viewer[™] (including embedded LA)
- PCIBUDDY[™]
- On-Line PRBS loopback test
- On-Line Compliance pattern test
- Side-band Management Interface
 - I2C/SMBUS/JTAG
 - SPI EEPROM
- Standard Compliance
 - Compliant with PCI Express Base Specification Revision 3.1
 - Compliant with PCI Express CEM Specification Revision 3.0
 - Compliant with Advanced Configuration Power Interface (ACPI) Specification
 - Compliant with System Management (SM) Bus, Version 2.0
- Power & Package
 - Two power rails (0.95V and 1.8V)
 - Power consumption: 4.11W (full-loading at T_j=80°C)
 - Totally Lead-Free & Fully RoHS Compliant (Notes 1 & 2)
 - Halogen and Antimony Free. "Green" Device (Note 3)
 - For automotive applications requiring specific change control (i.e. parts qualified to AEC-Q100/101/200, PPAP capable, and manufactured in IATF 16949 certified facilities), please [contact us](#) or your local Diodes representative.
<https://www.diodes.com/quality/product-definitions/>
 - Packages: 324-pin HFC 19mm x 19mm package

Notes:

1. No purposely added lead. Fully EU Directive 2002/95/EC (RoHS), 2011/65/EU (RoHS 2) & 2015/863/EU (RoHS 3) compliant.
2. See <https://www.diodes.com/quality/lead-free/> for more information about Diodes Incorporated's definitions of Halogen- and Antimony-free, "Green" and Lead-free.
3. Halogen- and Antimony-free "Green" products are defined as those which contain <900ppm bromine, <900ppm chlorine (<1500ppm total Br + Cl) and <1000ppm antimony compounds.

2 GENERAL DESCRIPTION

Similar to the role of PCI/PCIX Bridge in PCI/PCIX bus architecture, the basic function of PCI Express (PCIe) Switch is to expand the connectivity to allow more end devices being reached by host controllers in terms of PCIe serial interconnect architecture. This 16-lane and 8-port PCIe Switch can extend the connections ranged from 2 to 7 PCIe devices by means of its flexible port and lane configurations. It provides users the variety to expand or fan-out the PCI Express lanes from one host based upon their application needs. On top of that, one port of the packet switch can be configured to connect with other host, so that the dual-host usage case can be realized.

In PCI Express system bus hierarchy, the packet switch can be visualized as a logical assembly of multiple virtual PCI-to-PCI Bridge (PPB), which represents either upstream or downstream port. Also, normally all of the primary buses of downstream ports and secondary bus of upstream port are shared with one common virtual PCI Bus. In terms of the port configuration setting in a single host environment, the packet switch PI7C9X3G816GP can be enumerated with one upstream-port PPB and up to 7 downstream-port PPBs.

The chip adopts a Multiple-Ring as switch core for reaching to each individual port. There are eight ports attached to the Multiple-Ring allowing upstream, downstream and peer-to-peer traffic exchanges simultaneously. Each port employs the structure of Combined Input and Output Queue (CIOQ) for buffer management. The main reason for choosing CIOQ is that the required memory bandwidth of input queue equals to the line rate of ingress port rather than increasing proportionally with port numbers as an output queue switch does. The CIOQ at each ingress port contains separate dedicated queues to store posted data, non-posted requests and completion packets. The packets are arbitrated to the egress port based upon the ID or address carried in packet header and PCIe transaction-ordering rule.

Packets can be forwarded in downstream, upstream or peer-to-peer direction concurrently. For the packets without ordering enforcement, they are permitted to pass over each other in cases where the addressed egress port is available to accept them. This can mitigate the issue of Head-Of-Line (HOL) blocking and also not affecting the operation of producer-consumer model, which is required to be retained to prevent from system hang-up problem. On the other hand, the replay buffer at each egress port (output queue) enhances data integrity by preserving the transmitted packets until the appropriate ACK is returned by the link partner. As the out-going packets can be stored in replay buffer, this can gain the maximum throughput and efficiency of the Switch. Another advantage of implementing CIOQ in PCIe Switch is that the credit announcement to the counterpart is simplified and streamlined in terms of the credit-based flow control protocol. The protocol requires that each ingress port maintains the credits independently without checking other ports' credit availability, which is otherwise required by pure output queue architecture.

The Switch supports several advanced features of latest PCI Express specification. They are respectively Access Control Service (ACS), Multi-Cast, Atomic Operation, Alternate Routing ID (ARI), Address Translation (AT) packet forwarding, Latency Tolerance Reporting (LTR) and Optimized Buffer Flush Fill (OBFF) etc. ACS allows the host system to have more control on peer-to-peer switch traffic. This can be a critical requirement in virtual machine system. Multi-Cast is an extended capability of PCIe switch to facilitate posted packets forwarded to a group of downstream ports efficiently. The switch is also capable of being a routing element for Atomic Operation commands, which has the advantages of synchronization among multiple processors or multiple-thread environment. When ARI capability is turned on, the ID routing has an alternative interpretation on Device and Function numbers. The Function number can be increased from 3 bits to 8 bits and no device number any more. This allows the downstream port of packet switch forwarding packets with up to 256 Functions. The LTR and OBFF are message-type packets for communicating between host and end-devices to achieve platform-wise power management. The switch needs to response these two messages for synchronizing the power states of each node in the PCIe interconnect architecture.

In addition to port fan-out function, the PI7C9X3G816GP can be configured to facilitate inter-processor communication between two Processors or between Processor and an intelligent adaptor configured in processor mode. As usual, the upstream port of packet switch is hooked up a host. When configuring one downstream port of the switch into CDEP mode, this port will be connected to another host rather than an endpoint. The packet switch then allows these two distinct hosts allocating their own PCIe bus and memory resources and makes the packet transfer happening between them by means of resource translation.

PI7C9X3G816GP supports embedded Direct Memory Access (DMA) capability to move data between two address locations that are set up via DMA channels. There are four physical DMA channels implemented in PI7C9X3G816GP and each physical channel can be shared by two virtual channels. So a total of eight DMA channels can be enabled in the packet switch to enable eight pairs of locations transferring data simultaneously. The DMA engine is configured and managed by a software driver running on the hosts connected to the upstream port or CD ports. In terms of the address locations and DMA ownership, the DMA engines can be used in a variety of applications such as device status collection, peer-to-peer host transfer and peer-to-peer end-point transfer etc.

3 PIN DESCRIPTION

3.1 PCI EXPRESS INTERFACE SIGNALS

NAME	PIN	TYPE	DESCRIPTION
REFCLKP[2:0] REFCLKN[2:0]	M17,M14,G14 M16,M13,G15	I	<p>Reference Clock Input Pairs: Connect to 100MHz differential clock source.</p> <p>Please refer to reference clock operational mode for how to connect REFCLKP/N[2:0] to clock sources.</p> <p>The reference clock input is an unterminated AC coupled input. So the off-chip clock source must be terminated with both serial and parallel resistor network. Please refer to PCIe CEM specification for detail on how to realize on-board termination implementation.</p>
RESREF	N13	I	<p>Reference Resistor Connection: Attach RESREF an external resistor with the precision of 200 ohm 1% 100-ppm/C to ground on the board. The reference resistor is used for calibration of RX and TX termination when the chip comes out of reset or a manual PHY tuning request is made.</p>
PERP[15:0]	U16,U15,U14,U13,U12,U11,U10,U9, B9,B10,B11,B12,B13,B14,B15,B16	I	<p>PCI Express Data Serial Input Pairs: High-Speed Differential data receive signals.</p> <p>Please see the section of port/lane configuration.</p>
PERN[15:0]	V16,V15,V14,V13,V12,V11,V10,V9, A9,A10,A11,A12,A13,A14,A15,A16		
PETP[15:0]	P17,P16,P15,P14,P13,P12,P11,P10, E9,E10,E11,E12,E13,E14,E15,E16	O	<p>PCI Express Data Serial Output Pairs: High-Speed Differential data transmit signals.</p> <p>Please see the section of port/lane configuration.</p>
PETN[15:0]	R17,R16,R15,R14,R13,R12,R11,R10, D9,D10,D11,D12,D13,D14,D15,D16		
PERST_L	F18	I	<p>System Reset (Active LOW): When PERST_L is asserted, the internal states of whole chip except sticky logics are initialized. This is a global reset to all operational modes of packet switch.</p> <p>This pin has internal pull-up. If no board trace is connected to this pin, the internal pull-up resistor of this pin is enough. However, if pin is connected to a board trace and not driven, it is recommended that an external 5.1K-ohm pull-up resistor be used.</p>

3.2 CONFIGURATION STRAPPING SIGNALS

NAME	PIN	TYPE	DESCRIPTION										
CHIPMODE[1:0]	K15,K16	I	<p>Chip Operational Mode: These two input signals decide at which operational mode the chip is chosen.</p> <table border="1"> <thead> <tr> <th>CHIP_MODE[1:0]</th> <th>Operational Mode</th> </tr> </thead> <tbody> <tr> <td>00</td> <td>Normal</td> </tr> <tr> <td>01</td> <td>IDDQ/MBIST</td> </tr> <tr> <td>10</td> <td>AC JTAG</td> </tr> <tr> <td>11</td> <td>PHY Testing</td> </tr> </tbody> </table> <p>These pins have internal pull-down resistors. If no board trace is connected to these pins, the internal pull-down resistors of these pins are enough. However, if pins are connected to a board trace and not driven, it is recommended that external 330-ohm pull-down resistors be used.</p>	CHIP_MODE[1:0]	Operational Mode	00	Normal	01	IDDQ/MBIST	10	AC JTAG	11	PHY Testing
CHIP_MODE[1:0]	Operational Mode												
00	Normal												
01	IDDQ/MBIST												
10	AC JTAG												
11	PHY Testing												
PORTCFG[2:0]	C7,C12,C15	I	<p>Port Configuration: They are used to determine how 16 lanes are distributed among ports.</p> <p>Please refer to Port-Lane Configuration.</p> <p>These strapping pins have no built-in internal resistors and can not be left NC. These pins require the external 5.1K-ohm pull-up resistors or</p>										

NAME	PIN	TYPE	DESCRIPTION
			330-ohm pull-down resistors.
CKMODE	F17	I	<p>Clock Operational Mode: It is used define the relationship between physical SERDES lanes and reference clock.</p> <p>When CKMODE is 0, all 16 lanes (0 ~15) of SERDES are driven by one reference clock source.</p> <p>When CKMODE is 1, 16 lanes of SERDES are driven by two separate reference clock source via two pairs of reference clock inputs. Please refer to reference clock operational mode for connection description.</p> <p>This pin has internal pull-down resistor. If no board trace is connected to these pins, the internal pull-down resistors of these pins are enough. However, if pin is connected to a board trace and not driven, it is recommended that external 330-ohm pull-down resistors be used.</p>
HOT_PLUG_EN_L	*K7	I	<p>Hot Plug Function Enable: It is used to determine the downstream port is capable of handling either managed or surprised hot plug events. Besides, the GPIO pins would be redefined for hot-plug function if HOT_PLUG_EN_L = 0.</p> <p>HOT_PLUG_EN_L and FATAL_ERR_L share the same pin.</p> <p>This pin has internal pull-up. If no board trace is connected to this pin, the internal pull-up resistor of this pin is enough. However, if pin is connected to a board trace and not driven, it is recommended that an external 5.1K- ohm pull-up resistor be used.</p>
PHY_SRAM_BYPASS	*A2	I	<p>PHY SRAM Bypass: When set, it will bypass PHY SRAM.</p> <p>PHY_SRAM_BYPASS and GPIO[30] share the same pin.</p> <p>This pin has internal pull-up. If no board trace is connected to this pin, the internal pull-up resistor of this pin is enough. However, if pin is connected to a board trace and not driven, it is recommended that an external 5.1K- ohm pull-up resistor be used.</p>
SMBUS_EN_L	U17	I	<p>System Manage Bus Enable: This signal determines either SMBUS or I2C protocol being selected. When tied high, I2C protocol is selected. When tied low, SMBUS protocol is chosen.</p> <p>This pin has internal pull-up resistor. If no board trace is connected to this pin, the internal pull-up resistor of this pin is enough. However, if pin is connected to a board trace and not driven, it is recommended that an external 5.1K-ohm pull-up resistor be used.</p>
PM_L11_EN_L	*K6	I	<p>PM L1.1 Function Enable: It is used to determine the downstream port is capable of PM L1.1 function. Besides, the GPIO[15:8] pins would be redefined for PM L1.1 function if PM_L11_EN_L = 0.</p> <p>PM_L11_EN_L and INTA_L share the same pin.</p> <p>This strapping pin has no built-in internal resistor and can not be left NC. This pin requires an external 5.1K-ohm pull-up resistor or 330-ohm pull-down resistor.</p>

3.3 HOT PLUG SIGNALS

NAME	PIN	TYPE	DESCRIPTION
SHCL_I2C	M10	OD	I2C Clock Signal of Serial Hot Plug Controller: This signal SHCL_I2C is connected to SCL pin of I2C IO expander or CPLD. This pin requires external 5.1K-ohm pull-up resistor.
SHDA_I2C	M11	OD	I2C Data Signal of Serial Hot Plug Controller: This signal SHDA_I2C is connected to SDA pin of I2C IO expander or CPLD. This pin requires external 5.1K-ohm pull-up resistor.

NAME	PIN	TYPE	DESCRIPTION
SHPCINT_L	M12	I	Interrupt Input (Active Low) of Serial Hot Plug Controller: This signal SHPCINT_L is connected to INT# output pin of I2C IO expander or CPLD. When asserted, it notifies Hot Plug Controller to access the port registers of I/O expander or CPLD for touching changed status to de-assert INT#.
HP_LED[7:0]	*T17,*E18,*D17,*D18,*C17,*C18, *B18,*A17	O	Hot Plug LED: These signals HP_LED[7:0] drive Amber LED state by following SFF-8489 IBPI specification. HP_LED[7:0] and GPIO[7:0] share the same pins.
HP_RST_L[7:0]	*K2,*K3,*K4,*K5,*K17,*M15, *L13,*L14	O	Surprised Hot Plug Reset: These signals HP_RST_L[7:0] drive reset signals to the hot plug slots. They can be controlled by either off-chip PERST_L when booting up system or internal hardware when device is hot plugged into the slot. HP_RST_L[7:0] and GPIO[23:16] share the same pins.
SURPRISE_HP	*A1	I	Disable Surprise Hot Plug Function: This signal is used to enable surprise or managed hot function. If SURPRISE_HP = 1, the operational type is “surprised”. If SURPRISE_HP = 0, the operational type is “managed”. SURPRISE_HP and GPIO[31] share the same pin. This pin has internal pull-up. If no board trace is connected to this pin, the internal pull-up resistor of this pin is enough. However, if pin is connected to a board trace and not driven, it is recommended that an external 5.1K- ohm pull-up resistor be used.

3.4 REFERENCE CLOCK OUTPUT AND CONTROL SIGNALS

NAME	PIN	TYPE	DESCRIPTION
REFCLKOP[7:0]	G5,G6,G7,G8,D6,D7,D8,A7	O	Integrated Reference Clock Output Pairs: 100MHz external differential HCSL clock outputs from integrated reference clock buffer.
REFCLKON[7:0]	H5,H6,H7,G9,E6,E7,E8,B7		
REFCLKIP REFCLKIN	A8 B8	I	Integrated Reference Clock Input Pair: Connect to external 100MHz differential clocks for the integrated reference clock buffer. This differential reference clock input pair can be left as unconnected if the integrated reference clock biffer is not used.
CKBUFPD_L	*D1	I	Integrated Reference Clock Buffer Power Down Signal: This signal CKBUFPD_L is used to shut down the integrated clock buffer. When CKBUFPD_L is asserted low, the integrated reference clock buffer and reference clock outputs are disabled. CKBUFPD_L and GPIO[26] share the same pin. This pin has internal pull-up. If no board trace is connected to this pin, the internal pull-up resistor of this pin is enough. However, if pin is connected to a board trace and not driven, it is recommended that an external 5.1K- ohm pull-up resistor be used.
CLKREQ_L[7:0]	*L15,*L17,*L18,*M18,*N18,*P18, *R18,*T18	OD	Reference Clock Request Signals: These signals CLKREQ_L[7:0] are used to request reference clock for active operation. Each port (i.e. 0..7) has its own clock request signal. When asserted, the reference clock is on for both ends of the link. When deasserted, the reference clock is off and both ends of the link are put under L1 sub-state of power management. CLKREQ_L[7:0] and GPIO[15:8] share the same pins. CLKREQ_L[7:0] pins have internal pull-up. If no board trace is connected to these pins, the internal pull-up resistors of these pins are enough. However, if pins are connected to a board trace and not driven, it is recommended that external 5.1K- ohm pull-up resistors be used.

NAME	PIN	TYPE	DESCRIPTION
CLKBUF_CMOS_EN_L	L16	I	Clock Buffer Input Select: It is used to select the input of integrated ref clock buffer. When set high, the input is came the external reference clock surce through REFCLKIP/N pin. When set low, the input is came from internal PHY clock and REFCLKIP/N pin need be tied to GND through 330-ohm resistor.

3.5 SIDE BAND MANAGEMENT SIGNALS

NAME	PIN	TYPE	DESCRIPTION
EECK	H16	I/O	EEPROM Clock: Clock signal to 4-wire EEPROM interface. Debug Mode Enable (Debug_Mode_EN_L): During system initialization, EECK acts as the Debug_Mode_EN_L pin. In debug mode, it need be tired to low through a 330-ohm pull-down resistor. This pin has internal pull-up resistor. If no board trace is connected to this pin, the internal pull-up resistor of this pin is enough. However, if pin is connected to a board trace and not driven, it is recommended that an external 5.1K-ohm pull-up resistor be used.
EEDI	J16	O	EEPROM Data Input: The switch outputs data to the Data Input pin of Serial EEPROM.
EEDO	H18	I	EEPROM Data Output: The switch inputs data from the Data Output pin of Serial EEPROM.
EECS_L	H17	O	EEPROM Chip Select (Active Low): The switch asserts this signal to enable Serial EEPROM.
SCL_I2C	K18	OD	SMBUS/I2C Serial Clock: System management or I2C Bus Clock. This pin requires an external 5.1K-ohm pull-up resistor.
SDA_I2C	J18	OD	SMBUS/I2C Serial Data: Bi-Directional System Management or I2C Bus Data. This pin requires an external 5.1K-ohm pull-up resistor.
I2C_ADDR[2:0]	V17,V18,U18	I	SMBUS/I2C Slave Address Bit [2:0]: These pins are used to configure the value of the three least significant bits of the switch 7-bit Slave address. These pins require the external 5.1K-ohm pull-up resistors or 330-ohm pull-down resistors.

3.6 MISCELLANEOUS CONTROL AND STATUS

NAME	PIN	TYPE	DESCRIPTION
PDC_L[7:0]	N9,P8,P9,R8,R9,T8,U8,V8	I	Present Detect: When PDC_L is asserted low, it indicates this port is present. Otherwise, it indicates this port is absent. These pins have internal pull-up. If no board trace is connected to these pins, the internal pull-up resistors of these pin are enough. However, if pins are connected to a board trace and not driven, it is recommended that external 5.1K- ohm pull-up resistors be used.
GPIO[31:0]	A1,A2,B1,B2,C1,D1,E1,F1,K2,K3,K4,K5,K17,M15,L13,L14,L15,L17,L18,M18,N18,P18,R18,T18,T17,E18,D17,D18,C17,C18,B18,A17	I/O	General Purpose Input and Output: These thirty-two general-purpose pins are programmed as either input-only or bi-directional pins by writing the GPIO output enable control register.
FATAL_ERR_L	K7	O	Fatal Error Output: It is asserted low when a Fatal error is detected.
INTA_L	K6	OD	Interrupt Output Enable: When driven low, it indicates that one or more of the following events/errors are detected: Hot Plug events, Link State events, General-Purpose Input Interrupt events, Device-Specific errors, Device-Specific CDEP Port Link Interface errors and events, CDEP-Virtual Doorbell events or CDEP-Link Doorbell events.

NAME	PIN	TYPE	DESCRIPTION
LNKSTS[7:0]	H15,H14,H13,H12,G13,G16,G17,G18	O	<p>Port Good Status: These signals indicate the link status of each port.</p> <p>OFF – Link is down Blinking, 512 ms ON, 512 ms OFF (1Hz) – Link Up at 2.5 GT/s Blinking, 256 ms ON, 256 ms OFF (2Hz) – Link Up at 5.0GT/s ON – Link Up at 8.0GT/s</p> <p>PORTGOOD_L[x] is correspondent to Port x, where y=0...7.</p>
TEST	C4	I	
NC	A3,A4,A5,A6,B3,B4,B5,B6,D2,D3,D4,D5,E2,E3,E4,E5,F6,G1,G2,G3,G4,H1,H3,H4,J1,J2,J3,J6,J7,L1,L2,L3,L4,L5,L6,L7,K1,M1,M3,M4,M5,M6,M7,M8,N1,N2,N3,P1,P2,P4,P5,P6,P7,R1,R2,R3,R4,R5,R6,R7,T1,T2,T4,U1,U3,U4,U5,U6,U7,V1,V2,V3,V4,V5,V6,V7		Not Connected: These pins can be just left open.

3.7 JTAG BOUNDARY SCAN SIGNALS

NAME	PIN	TYPE	DESCRIPTION
TCK	K13	I	Test Clock: Used to clock state information and data into and out of the chip during switch's boundary scan or PCIe PHY's internal registers access. When JTAG function is not implemented, this pin should be left open (NC).
TDI	J14	I	Test Data Input: Used (in conjunction with TCK) to shift data and instructions into the TAP in a serial bit stream. When JTAG function is not implemented, this pin should be left open (NC).
TDO	J15	O	Test Data Output: Used (in conjunction with TCK) to shift data out of the Test Access Port (TAP) in a serial bit stream. When JTAG function is not implemented, this pin should be left open (NC).
TMS	J13	I	Test Mode Select: Used to control the state of the Test Access Port controller. When JTAG function is not implemented, this pin should be pulled low through a 330-Ohm pull-down resistor.
TRST_L	J12	I	Test Reset (Active LOW): Active LOW signal to reset the TAP controller into an initialized state. When JTAG function is not implemented, this pin should be pulled low through a 330-Ohm pull-down resistor.
JTAG_SEL_L	A18	I	JTAG Selection (Active LOW): When set high, JTAG pins used for controlling switch's boundary scan, when set low, JTAG pins used for accessing PCIe PHY internal registers.

3.8 POWER PINS

NAME	PIN	TYPE	DESCRIPTION
VDDC	H9,H11,J8,J10,K9,K11,L8,L10,L12	P	VDDC Supply (0.95V): Used as digital core power pins.
C_VDDC	F7	P	VDDC Supply (0.95V): Used as reference clock power pins.
VDDR	F4,N4,N15,F15	P	VDDR Supply (1.8V): Used as digital I/O power pins.
C_VDDR	J4	P	VDDR Supply (1.8V): Used as reference clock power pins.
VP	F9,F11,F13,G10,M9,N6,N8,N10,N12,	P	VP Supply (0.95V): Used as PCI Express analog and core power pins.
VPH	C9,C10,T9	P	VPH Supply (1.8V): Used as PCI Express analog high voltage power pins.

NAME	PIN	TYPE	DESCRIPTION
VSS	B17,C2,C3,C5,C6,C8,C11,C13,C14, C16,E17,F2,F3,F5,F8,F10,F12,F14, F16,G11,G12,H2,H8,H10,J5,J9,J11, J17,K8,K10,K12,K14,L9,L11,M2, N5,N7,N11,N14,N16,N17,P3,T3, T5,T6,T7,T10,T11,T12,T13,T14, T15,T16,U2	P	Ground: Used as ground pins.

	18	17	16	15	14	13	12	11	10	9	8	7	6	5	4	3	2	1	
A	JTAG_SEL_L	GPIO [0]	PERN [0]	PERN [1]	PERN [2]	PERN [3]	PERN [4]	PERN [5]	PERN [6]	PERN [7]	REFCLK_IP	REFCLK_OP[0]	NC	NC	NC	NC	GPIO [30]	GPIO [31]	A
B	GPIO [1]	VSS	PERP [0]	PERP [1]	PERP [2]	PERP [3]	PERP [4]	PERP [5]	PERP [6]	PERP [7]	REFCLK_IN	REFCLK_ON[0]	NC	NC	NC	NC	GPIO [28]	GPIO [29]	B
C	GPIO [2]	GPIO [3]	VSS	PPORT_CFG[0]	VSS	VSS	PORT_CFG[1]	VSS	VPH	VPH	VSS	PORT_CFG[2]	VSS	VSS	TEST	VSS	VSS	GPIO [27]	C
D	GPIO [4]	GPIO [5]	PETN [0]	PETN [1]	PETN [2]	PETN [3]	PETN [4]	PETN [5]	PETN [6]	PETN [7]	REFCLK_OP[1]	REFCLK_OP[2]	REFCLK_OP[3]	NC	NC	NC	NC	GPIO [26]	D
E	GPIO [6]	VSS	PETP [0]	PETP [1]	PETP [2]	PETP [3]	PETP [4]	PETP [5]	PETP [6]	PETP [7]	REFCLK_ON[1]	REFCLK_ON[2]	REFCLK_ON[3]	NC	NC	NC	NC	GPIO [25]	E
F	PERST_L	CK_MODE	VSS	VDDR	VSS	VP	VSS	VP	VSS	VP	VSS	C_VDDC	NC	VSS	VDDR	VSS	VSS	GPIO [24]	F
G	LNKSTS [0]	LNKSTS [1]	LNKSTS [2]	REFCKLN [0]	REFCLKP [0]	LNKSTS [3]	VSS	VSS	VP	REFCLK_ON[4]	REFCLK_OP[4]	REFCLK_OP[5]	REFCLK_OP[6]	REFCLK_OP[7]	NC	NC	NC	NC	G
H	EEDO	E ECS_L	EBCK	LNKSTS [7]	LNTSTS [6]	LNTSTS [5]	LNKSTS [4]	VDDC	VSS	VDDC	VSS	REFCLK_ON[5]	REFCLK_ON[6]	REFCLK_ON[7]	NC	NC	VSS	NC	H
J	SDA_2C	VSS	EEDI	TDO	TDI	TMS	TRST_L	VSS	VDDC	VSS	VDDC	NC	NC	VSS	C_VDDR	NC	NC	NC	J
K	SCL_2C	GPIO [19]	CHIP_MODE[0]	CHIP_MODE[1]	VSS	TCK	VSS	VDDC	VSS	VDDC	VSS	FATAL_ERR_L	INTA_L	GPIO [20]	GPIO [21]	GPIO [22]	GPIO [23]	NC	K
L	GPIO [13]	GPIO [14]	CLKBUF_CMOS_EN_L	GPIO [15]	GPIO [16]	GPIO [17]	VDDC	VSS	VDDC	VSS	VDDC	NC	NC	NC	NC	NC	NC	NC	L
M	GPIO [12]	REFCLKP [2]	REFCKLN [2]	GPIO [18]	REFCLKP [1]	REFCKLN [1]	SHPC_INT_L	SHDA_2C	SHCL_2C	VP	NC	NC	NC	NC	NC	NC	VSS	NC	M
N	GPIO [11]	VSS	VSS	VDDR	VSS	RESREF	VP	VSS	VP	PDC_L [7]	VP	VSS	VP	VSS	VDDR	NC	NC	NC	N
P	GPIO [10]	PETP [15]	PETP [14]	PETP [13]	PETP [12]	PETP [11]	PETP [10]	PETP [9]	PETP [8]	PDC_L [5]	PDC_L [6]	NC	NC	NC	NC	VSS	NC	NC	P
R	GPIO [9]	PETN [15]	PETN [14]	PETN [13]	PETN [12]	PETN [11]	PETN [10]	PETN [9]	PETN [8]	PDC_L [3]	PDC_L [4]	NC	NC	NC	NC	NC	NC	NC	R
T	GPIO [8]	GPIO [7]	VSS	VSS	VSS	VSS	VSS	VSS	VSS	VPH	PDC_L [2]	VSS	VSS	VSS	NC	VSS	NC	NC	T
U	I2C_ADDR [0]	SMBUS_EN_L	PERP [15]	PERP [14]	PERP [13]	PERP [12]	PERP [11]	PERP [10]	PERP [9]	PERP [8]	PDC_L [1]	NC	NC	NC	NC	NC	VSS	NC	U
V	I2C_ADDR [1]	I2C_ADDR [2]	PERN [15]	PERN [14]	PERN [13]	PERN [12]	PERN [11]	PERN [10]	PERN [9]	PERN [8]	PDC_L [0]	NC	NC	NC	NC	NC	NC	NC	V

Figure 3-1 PI7C9X3G816GP Ball Assignment

4 FUNCTIONAL OVERVIEW

This chapter provides an overview of the PI7C9X3G816GP's major functions.

4.1 MODES OF OPERATIONS

The PI7C9X3G816GP supports two modes of operations.

- Base Mode (Fan-out Mode)
- Cross-Domain End-Point (CDEP Mode)

4.1.1 BASE MODE (FAN-OUT MODE)

The Base mode is one of the Fan-out mode types. In this mode, the PI7C9X3G816GP supports one upstream port and up to 7 down ports. Multiple virtual PCI-to-PCI bridges are connected by a virtual PCI bus, residing in the Switch.

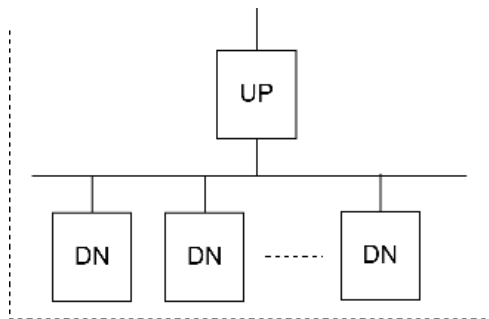

Figure 4-1 Base Mode (Fan-out Mode) Overview

4.1.2 Cross-Domain End-Point Mode

The switch supports a Cross-Domain End-Point (CDEP) mode allowing more than one host attached to PI7C9X3G816GP. When configured as CDEP mode, one of downstream port will be turned into CDEP port for additional host to connect with it. So the packets produced from different hosts can exchange through PI7C9X3G816GP for [system failover application](#).

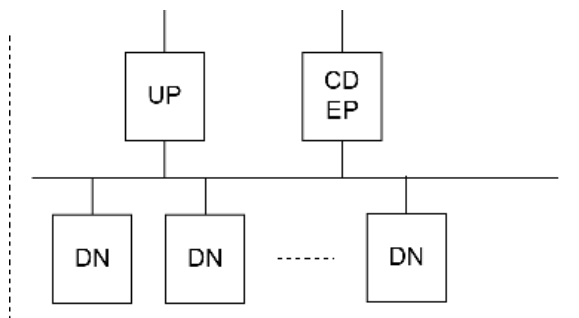

Figure 4-2 Cross-Domain End-Point Mode Overview

4.2 PHYSICAL LAYER CIRCUITS

The physical layer circuit design is defined as a converter between serial bus interface and the PHY Interface for PCI Express Architecture (PIPE). It contains Physical Media Attachment (PMA) and Physical Coding Sub-layer (PCS) blocks. PMA includes Serializer/ Deserializer (SERDES), PLL1, Adaptive TX and RX Equalization, Clock Recovery module, receiver detection circuit, electrical idle detector, and input/output buffers. PCS consists of two blocks for handling 128B/130B and 8B/10B encoder/decoder, SYNC code-word framer, receiver elastic buffer, and PIPE PHY control/status circuitries. To provide the flexibility for bifurcating multiple lanes into different port width of configuration, the control and status signals of each lane can be combined for MAC to access as a link basis. In addition, a pair of PRBS generator and checker is included for PHY built-in self-test. The main functions of physical layer circuits include the conversion between serial-link and parallel bus, provision of clock source for the

The driver characteristics including amplitude, and pre-emphasis, on transmit (TX) side are programmable. The PHY on receive (RX) side is capable of automatic calibration and configuration of the internal circuits to maximize receiving performance. In addition, the PHY provides the flexibility for user to override or disable the automatically calibrated settings.

Definition of the Switch Downstream Port's Transmitter presets can be set by [LANE EQUALIZATION CONTROL REGISTER](#) (OFFSET from 21Ch – 238h). The encoding for the Transmitter presets is provided in Table 4-1. The Transmitter Preset encoding of 1010b corresponds to the maximum Vtx-boost.

Table 4-1 Transmitter Preset Encoding

Encoding	De-emphasis (dB)	Preshoot (dB)
0000b	-6.02	0.00
0001b	-3.74	0.00
0010b	-4.44	0.00
0011b	-2.50	0.00
0100b	0	0.00
0101b	0	1.94
0110b	0	2.50
0111b	-6.02	3.52
1000b	-3.52	3.52
1001b	0	3.74
1010b	-9.12	0.00
1011b~1111b	Reserved	Reserved

4.3 MEDIA ACCESS CONTROL (MAC)

The Media Access Control (MAC) block, which is consisted of physical layer packet boundary delineation and formation, multiple lanes de-skew, scrambler/de-scrambler, clock correction from inserting skip order-set, PIPE-related control/status circuits and Link Training Status State Machine (LTSSM), is implemented to interface physical layer with data link layer, build and maintain the link between two link partners.

The switch allows users to control GEN3 Link EQ parameters and link training behavior such as detection, compliance and lane reverse etc. The switch implements a group of LTSSM CSR registers located at offset starting from 380h to 3A0h to configure LTSSM operation.

¹ Multiple lanes could share the PLL.

4.4 DATA LINK LAYER (DLL)

The Data Link Layer (DLL) provides a reliable data transmission between two PCI Express points. An ACK/NACK protocol is employed to guarantee the integrity of the packets delivered. Each Transaction Layer Packet (TLP) is protected by a 32-bit LCRC for error detection. The DLL receiver performs LCRC calculation to determine if the incoming packet is corrupted in the serial link. If an LCRC error is found, the DLL transmitter would issue a NACK data link layer packet (DLLP) to the opposite end to request a re-transmission, otherwise an ACK DLLP would be sent out to acknowledge on reception of a good TLP.

The moment for issuing ACK DLLP is dependent on a time-out event of ACK latency timer or transmitter channel availability. According to PCI Express specification, the calculation of ACK latency timer is based upon maximum payload size, link width, TLP overhead, ACK factor and internal processing delay. The calculated values are determined by hardware as a default to meet PCIe specified requirement. On the other hand, the chip provides a flexibility to change the value of ACK latency timer by programming the bit 11 ~ bit 0 of DLL CSR registers at offset [420/424/428H](#) for G1/G2/G3 speed. The programmable ACK latency timer can regulate the frequency of issuing ACK DLLP. This can facilitate performance tuning under a burst of TLP in transmission.

In the transmitter, a retry buffer is implemented to store the transmitted TLPs whose corresponding ACK/NACK DLLP have not been received yet. When an ACK is received, the TLPs with sequence number equals to and smaller than that carried in the ACK would be flushed out from the buffer. If a NACK is received or no ACK/NACK is returned from the link partner after the replay timer expires, then a replay mechanism built in DLL transmitter is triggered to re-transmit the corresponding packet that receives NACK or time-out and any other TLP transmitted after that packet.

Meanwhile, the DLL is also responsible for the initialization, updating, and monitoring of the flow-control credit. All of the flow control information is carried in DLLP that is sent to the other end of link. Unlike TLP, DLLP is guarded by 16-bit CRC to detect if data corruption occurs. Furthermore, DLLP is used to handshake protocol between link parties for entering different power states such as ASPM L0s/L1 and PM L1 etc.

The chip implements a group of DLL CSR registers started from offset [420h](#) to [46Ch](#) for users to control the Flow control packet behavior, DLL packet error status report, replay timer and ACK latency timer etc.

4.5 TRANSACTION LAYER RECEIVE BLOCK (TLP DECAPSULATION)

The receiving portion of the transaction layer performs header information retrieval and validates the correctness of the transaction type and format. If the TLP is found to contain an illegal header or the indicated packet length mismatches with the actual packet length, then a Malformed TLP is reported as an error associated with the receiving port. PCIe also supports End-to-End CRC operation to ensure end-to-end data integrity, a 32-bit ECRC is checked against the TLP at the receiver if the digest bit is set in header. Please note for ECRC operation, it is necessary both of EP and RC to support ECRC as well.

4.6 ROUTING

The transaction layer implements three types of routing protocols: ID-based, address-based, and implicit routing. For configuration reads, configuration writes, transaction completion, and user-defined messages, the packets are routed by their destination ID constituted of bus number, device number, and function number. Address routing is employed to forward I/O or memory transactions to the destination port, which is located within the address range indicated by the address field carried in the packet header. The packet header indicates the packet types including memory read, memory write, IO read, IO write, Message Signaling Interrupt (MSI) and user-defined message. Implicit routing is

mainly used to forward system message transactions such as virtual interrupt line, power management, and so on. The message type embedded in the packet header determines the routing mechanism.

If the incoming packet cannot be forwarded to any other port due to a miss to hit the desired address range or targeted ID, this is considered as Unsupported Request (UR) packet, which is similar to a master abort event in PCI protocol.

In addition to following standard packet routing rule, the chip also implements a group of TL CSR registers started from offset [4C0h](#) to [4C8h](#) for users to control packet forwarding mode, packet ordering and arbitration scheme etc.

4.7 QUEUE

Six TLP packet types are defined in PCI Express architecture: Memory read/write, IO read/write, Config read/write, Completions, Messages, and Atomic. Each of these packet types fits into the separate switch queues: Posted Request Header (PH), Posted Request Data payload (PD), Non-Posted Request Header (NPH), Non-Posted Data Payload (NPD), Completion Header (CPLH) and Completion Data payload (CPLD). Each packet with different type would be put into a separate queue in order to facilitate the following ordering processor. NPD only contains one DW for all Non-post requests except CAS AtomicOP with 128-bit operand size, which requires two DWs, so it can be merged with the corresponding NPH into a common queue named NPHD.

4.7.1 POSTED REQUEST HEADER (PH)

PH queue provides TLP header spaces for posted memory writes and various message request headers. The types of TLP stored in this queue are MWr, Msg and MsgD. Each header space occupies sixteen bytes to accommodate 3 DW or 4 DW headers. The number of entries in PH range from 8 to 16 depending on the lane width of link.

4.7.2 POST REQUEST DATA (PD)

PD queue is used for storing posted request data. If the received TLP is a posted request type such as MWr or MsgD, and contained payload other than the header, the payload data would be put into PD queue. The size of PD queue ranges from 2KB to 4KB depending on the lane width of link.

4.7.3 NON-POSTED REQUEST HEADER AND DATA (NPHD)

NPHD queue provides TLP header spaces for non-posted request packets, which include memory read, IO read, IO write, configuration read, configuration write and AtomicOP requests. The types of TLP stored in this queue are MRd, MRdLk, IORd, IOWr, CfgRd0/CfgRd1, CfgWr0/CfgWr1, FetchAdd, Swap and CAS. Usually only IO or configuration write and Atomic requests are given additional data credit. The other TLP type is just given header credit. Each header space takes twenty-four bytes to accommodate the following combinations: 3-DW header, 4-DW header, 3-WD header with 1-DW data, 3-WD header with 2-DW data, 4-DW header with 1-DW data and 4-DW header with 2-DW data. In total, the number of entries in NPHD range from 8 to 16 depending on the lane width of link.

4.7.4 COMPLETION HEADER (CPLH)

CPLH queue provides TLP header space for completion packets. The types of TLP stored in this queue are Cpl, CplD, CplLk and CplDLk. Each header space takes twelve bytes to accommodate a 3-DW header. Please note that there are no 4-DW completion headers. The number of entries in CPLH range from 8 to 16 depending on the lane width of link.

4.7.5 COMPLETION DATA (CPLD)

CPLD queue is used for storing completion data. If the received TLP is a CplD or CplDLk type and contained payload other than the header, the payload data would be put into CPLD queue. The size of CPLD queues range from 2KB to 4KB depending on the lane width of link.

4.8 TRANSACTION ORDERING

A set of ordering rules is defined to regulate the transactions on the PCI Express Switch including Memory, IO, Configuration and Messages, in order to avoid deadlocks and to support the Producer-Consumer model. The ordering rules defined in Table 4-2 apply within a single Traffic Class (TC). There is no ordering requirement among transactions within different TC labels. Since the transactions with the same TC label are not allowed to map into different virtual channels, it implies no ordering relationship between the traffic in VC0.

Table 4-2 Summary of PCI Express Ordering Rules

Row Pass Column	Posted Request	Read Request	Non-posted Write Request	Read Completion	Non-posted Write Completion
Posted Request	Yes/No ¹	Yes ⁵	Yes ⁵	Yes ⁵	Yes ⁵
Read Request	No ²	Yes	Yes	Yes	Yes
Non-posted Write Request	No ²	Yes	Yes	Yes	Yes
Read Completion	Yes/No ³	Yes	Yes	Yes	Yes
Non-Posted Write Completion	Yes ⁴	Yes	Yes	Yes	Yes

1. When the Relaxed Ordering Attribute bit is cleared, the Posted Request transactions including memory write and message request must complete on the egress bus in the order in which they are received on the ingress bus. If the Relaxed Ordering Attribute bit is set, the Posted Request is permitted to pass over other Posted Requests occurring before it.
2. A Read Request transmitting in the same direction as a previously queued Posted Request transaction must push the posted write data ahead of it. The Posted Request transaction must complete on the egress bus before the Read Request can be attempted on the egress bus. The Read transaction can go to the same location as the Posted data. Posted read requests are not allowed to pass posted write transactions due to the concern that if the read and write are to the same location, the subsequent data returned from the read request would be stale data.
3. When the Relaxed Ordering Attribute bit is cleared, a Read completion must “pull” ahead of previously queued posted data transmitting in the same direction. In this case, the read data transmits in the same direction as the posted data, and the requestor of the read transaction is on the same side as the completer of the posted transaction. The posted transaction must deliver to the completer before the read data is returned to the requestor. If the Relaxed Ordering Attribute bit is set, then a read completion is permitted to pass a previously queued Memory Write or Message Request.
4. Non-Posted Write Completions are permitted to pass a previous Memory Write or Message Request transaction. Such transactions are actually transmitting in the opposite directions and hence have no ordering relationship.
5. Posted Request transactions must be given opportunities to pass Non-posted Read and Write Requests as well as Completions. Otherwise, deadlocks may occur when some older bridges, which do not support delayed transactions are mixed with PCIe Switch in the same system. A fairness algorithm is used to arbitrate between the Posted Write queue and the Non-posted transaction queue

4.9 PORT ARBITRATION

Among multiple ingress ports, the port arbitration built in the egress port determines which incoming packets to be forwarded to the output port. Switch support hardware fixed Round Robin arbitration algorithm. The port arbitration is held within the Virtual Channel 0. At the upstream ports, in addition to the inter-port packets, the intra-port packet such as configurations completion would also join the arbitration loop to get the service from Virtual Channel 0.

4.10 FLOW CONTROL

PCI Express employs Credit-Based Flow Control mechanism to make buffer utilization more efficient. The transaction layer transmitter ensures that it does not transmit a TLP to an opposite receiver unless the receiver has enough buffer space to accept the TLP. The transaction layer receiver has the responsibility to advertise the free buffer space to an opposite transmitter to avoid packet stale. In this Switch, each port has its own separate queues for different traffic types (Posted, Non Posted and Completion) and the credits of each type are continually updated via the data link layer on the fly. The data link layer compares the current available credits with the monitored ones and reports the updated credit to the counterpart. If no new credit is acquired, the credit reported is scheduled for every 30 us to prevent the link from entering retrain. On the other hand, the receiver at each egress port gets the usable credits from the opposite end in a link. The egress port notifies the usable credit information to all ingress ports to receive packets that are intended to that egress port.

4.11 TRANSACTION LAYER TRANSMIT BLOCK (TLP ENCAPSULATION)

The transmit portion of transaction layer performs the following functions. They construct the all types of forwarded TLP generated from VC arbiter, respond with the completion packets when the local resource (i.e. configuration register) is accessed, and regenerate the message that terminates at receiver to RC if acting as an upstream port.

4.12 ACCESS CONTROL SERVICE (ACS)

Traditionally, the packet routing between the peer-to-peer downstream ports is determined by either the address or ID field embedded in the packet header. Access Control Service (ACS) provides a mechanism for customer to selectively control access between PCI Express Endpoints attached to the downstream ports of packet switch. If ACS is enabled in the ingress port, the peer-to-peer packet forwarding will follow the rule sets of ACS rather than the destination ID or address. ACS is implemented as a set of capabilities and control registers in the associated hardware component. It brings the following benefits such as preventing the silent data corruption presented in Requests from being incorrectly routed to a peer Endpoint, validating every Request transaction between two downstream components and enabling direct routing of peer-to-peer Memory Requests whose addresses have been translated when ATS system is being used. ACS is usually enabled for directing all peer-to-peer traffic between downstream ports to upstream port.

Please refer to [ACS Extended Capability](#) registers at offset 1C0h for more information.

4.13 MULTICAST OPERATION

This is a PCIe optional feature allowing posted packets delivered to multiple endpoints with an efficient way. For some application, more than one target would receive the same packet. By using traditional unicast operation, this packet would be repeatedly transmitted until all targets receive the same packet. The multicast operation would only require one-time transmission to serve all targets. The PCIe spec defines a Multicast Capability structure containing a Multicast address range that is dividable into multiple Multicast Group (MCG) with the size of Multicast Window to enable multicast operation. The multicast address range must be in the same host domain. Multicast is not translated into other host domain address location for cross-domain multicast transactions.

When the incoming packet hits the dedicated MCG within the Multicast address range defined in the ingress port, it will be simultaneously forwarded to the selected egress ports, which have the corresponding MCG bit set in MC_Receive register, if no blocking happens in ingress port. The ingress port also allows the multicast-hit packet being dropped by enabling the corresponding MCG bit in MC_Block_All or MC_Block_Untranslated register.

Please refer to [Multicast Extended Capability](#) registers at offset 1D0h for more information.

5 CHIP INITIALIZATION

5.1 PORT-LANE CONFIGURATION

5.1.1 MODE SELECTION

PI7C9X3G816GP can be configured into 2 Ports, 3 Ports, 4 Ports, 5 Ports, and 8 Ports across 16 Lanes by employing [PORTCFG\[2:0\]](#) pins.

Table 5-1 Mode Selection

PORTCFG[2]	PORTCFG[1]	PORTCFG[0]	Functional Mode
0	0	1	2Port-16Lane Configuration
0	1	0	3Port-16Lane Configuration
0	1	1	4Port-16Lane Configuration ^{Note}
1	0	0	5Port-16Lane Configuration
1	0	1	8Port-16Lane Configuration

Note: When PORTCFG_x[2:0] set to 011b (416 mode), it can support bifurcation. Based on “Fix_416_result” register setting, switch can be configured to 4Port-16Lane, 5Port-16Lane, 6Port-16Lane, 7Port-16Lane and 8Port-16Lane configurations. See [offset 55Ch](#) for more detail.

5.1.2 LANE MAPPING

The table below shows the mapping of the lanes to the transmission and receive pairs.

Table 5-2 Lane Mapping

Lane	TX Pair	RX Pair
Lane 0	PETP[0]PETN[0]	PERP[0]PERN[0]
Lane 1	PETP[1]PETN[1]	PERP[1]PERN[1]
Lane 2	PETP[2]PETN[2]	PERP[2]PERN[2]
Lane 3	PETP[3]PETN[3]	PERP[3]PERN[3]
Lane 4	PETP[4]PETN[4]	PERP[4]PERN[4]
Lane 5	PETP[5]PETN[5]	PERP[5]PERN[5]
Lane 6	PETP[6]PETN[6]	PERP[6]PERN[6]
Lane 7	PETP[7]PETN[7]	PERP[7]PERN[7]
Lane 8	PETP[8]PETN[8]	PERP[8]PERN[8]
Lane 9	PETP[9]PETN[8]	PERP[9]PERN[9]
Lane 10	PETP[10]PETN[10]	PERP[10]PERN[10]
Lane 11	PETP[11]PETN[11]	PERP[11]PERN[11]
Lane 12	PETP[12]PETN[12]	PERP[12]PERN[12]
Lane 13	PETP[13]PETN[13]	PERP[13]PERN[13]
Lane 14	PETP[14]PETN[14]	PERP[14]PERN[14]
Lane 15	PETP[15]PETN[15]	PERP[15]PERN[15]

5.1.3 PORT NUMERING

The port number is given in the port number field of link capability register. Each port has different link width capability, which is also defined in Maximum Link Width field of this capability register. Following table is the port number in the switch and the corresponding maximum link width.

Table 5-3 Port Numbering

Port Number	P0	P1	P2	P3	P4	P5	P6	P7
Link Width	x8	x2	x4	x2	x8	x2	x4	x2

5.1.4 PORT-LANE MAPPING

The table below shows the mapping of the lanes to ports in different functional modes.

Table 5-4 Port-Lane Mapping

	2-Port	3-Port	4-Port	5-Port	8-Port
Lane 0	P0	P0	P0	P0	P0
Lane 1	P0	P0	P0	P0	P0
Lane 2	P0	P0	P0	P0	P1
Lane 3	P0	P0	P0	P0	P1
Lane 4	P0	P0	P2	P0	P2
Lane 5	P0	P0	P2	P0	P2
Lane 6	P0	P0	P2	P0	P3
Lane 7	P0	P0	P2	P0	P3
Lane 8	P4	P4	P4	P4	P4
Lane 9	P4	P4	P4	P4	P4
Lane 10	P4	P4	P4	P5	P5
Lane 11	P4	P4	P4	P5	P5
Lane 12	P4	P6	P6	P6	P6
Lane 13	P4	P6	P6	P6	P6
Lane 14	P4	P6	P6	P7	P7
Lane 15	P4	P6	P6	P7	P7

Note: Switch supports automatic lane reversal within a port.

5.2 CLOCK SCHEME

5.2.1 REFERENCE CLOCK OPERATION MODES

The Switch supports two different reference clock operational modes defined by CKMODE. If CKMODE is tied to “0”, the Switch sourced from reference clocks is operating under BASE mode. If CKMODE is tied to “1”, the switch driven by reference clocks is operating under Cross Domain Separate Reference clock (CDSR) mode. The configured mode determines how the reference clock sources are connected to REFCLKP/N[2:0] input pins.

For example, when the Switch is configured to be in the BASE mode, all of the 16 lanes are driven by REFCLKP/N[0]. In this mode, REFCLKP/N[2:1] are recommended to be connected to the ground. When the Switch is set to be in CDSR mode, it allows two different reference clock sources to drive these 16 lanes. The users can decide how the reference clocks are connected to the appropriate ports based on the appropriate port lane mapping.

When Switch is configured to be in CDSR mode, chip operates in multiple reference clock domains. In this mode, some of ports work in one reference clock domain while others work in another domain. Each domain can turn on its own SSC function, and the Switch supports SSC isolation feature to allow ports in different SSC domains to transfer packets to each other correctly, given that the frequency differences are within 5600ppm.

The following table illustrates the connections of REFCLKP/N[2:0] in various use cases when CKMODE is set to BASE mode. The reference clock source comes from Root Complex (RC). The clock signal is distributed through buffer or generator to REFCLKP/N[2:0].

Table 5-5 REFCLKP/N[2:0] connections when BASE mode is chosen

Usage Case	REFCLK Architecture	REFCLKP/N[0]	REFCLKP/N[2:1]
Single Fan-out	Common/SRNS/SRIS	RC for all ports	GND

If CKMODE is set to CDSR, the use case is similar to dual-host domain. The REFCLK architecture is viewed as in SSC isolation. The Switch can be splitted into 2 host domains with the host port of P0 and P4. These two host ports can be linked at x4 lane-width. The reference clock drives P0 via REFCLKP/N[0], which is the main clock for the entire chip. In this mode, REFCLKP/N[0] is isolated from REFCLKP/N[1], which is connected to P4. REFCLKP/N[0] and REFCLKP/N[1] are sourced differently from the RC in their own host domains. The following table illustrates the connection of REFCLKP/N[1:0] in SSC isolation condition.

Table 5-6 REFCLKP/N[2:0] connections when CDSR mode is chosen

Port 0	Port 4	REFCLKP/N[0]	REFCLKP/N[1]	REFCLKP/N[2]
x8 or x4	x8	RC[0]	RC[1]	GND
x8 or x4	x4	RC[0]	RC[1]	RC[0]

5.2.2 INTEGRATED REFERENCE CLOCK BUFFER

The built-in Integrated Reference Clock Buffer of the PI7C9X3G816GP supports eight reference clock outputs. The strapping pin CKBUFPD_L to enable or disable the internal clock buffer feature.

When CKBUFPD_L pin is de-asserted, the integrated reference clock buffer is enabled. The clock buffer distributes a single 100 MHz reference clock input to eight reference clock output pairs, REFCLKOP/N[7:0]. The integrated reference clock buffer supports two different operation modes which set by CLKBUF_CMOS_EN_L pins. When CLKBUF_CMOS_EN_L set “1”, the integrated clock buffer requires 100 MHz differential clock inputs through REFCLKIP/N pins as shown in Table 12-4. When CLKBUF_CMOS_EN_L set “0”, REFCLKIP/N are recommended to be connected to the ground.

When CKBUFPD_L pin is asserted high, the integrated clock buffer is in power down mode and disabled. The 100 MHz reference clock output pairs are disabled.

The connection of REFCLKOP/N[7:0] pins of PI7C9X3G816GP and the reference clock input of downstream port devices have to follow the table shown below if L1.1 is implemented.

Table 5-7 Connection Map for REFCLKOP/N[7:0]

Reference Clock Source Pins	REFCLKOP[0] REFCLKON[0]	REFCLKOP[1] REFCLKON[1]	REFCLKOP[2] REFCLKON[2]	REFCLKOP[3] REFCLKON[3]	REFCLKOP[4] REFCLKON[4]	REFCLKOP[5] REFCLKON[5]	REFCLKOP[6] REFCLKON[6]	REFCLKOP[7] REFCLKON[7]
Reference Clock Destination Pins	Note	Downstream Port 1 device	Downstream Port 2 device	Downstream Port 3 device	Downstream Port 4 device	Downstream Port 5 device	Downstream Port 6 device	Downstream Port 7 device

Note: When CKMODE is set to BASE mode, REFCLKP/N[0] can be connected to REFCLKOP/N[0] or external reference clock source. When CKMODE is set to CDSR mode, REFCLKOP/N[0] is un-used and REFCLKP/N[2:0] are connected to external reference clock sources which need belong to the same clock buffer.

The REFCLKOP/N[7:0] is not only enabled or disabled by a global control signal CKBUFPD_L, but also controlled by CLKREQ_L[7:0] pins and internal downstream-port device clock status individually based on L1 PM Substate rule. The output control signals for REFCLKOP/N[7:0] are mapped as the following tables.

Table 5-8 Output Control for REFCLKOP/N[7:0]

Reference Clock Source Pins	REFCLKOP[0] REFCLKON[0]	REFCLKOP[1] REFCLKON[1]	REFCLKOP[2] REFCLKON[2]	REFCLKOP[3] REFCLKON[3]	REFCLKOP[4] REFCLKON[4]	REFCLKOP[5] REFCLKON[5]	REFCLKOP[6] REFCLKON[6]	REFCLKOP[7] REFCLKON[7]
Clock Request Control Pins	CLKREQ_L[0]	CLKREQ_L[1]	CLKREQ_L[2]	CLKREQ_L[3]	CLKREQ_L[4]	CLKREQ_L[5]	CLKREQ_L[6]	CLKREQ_L[7]

Note: When CKMODE is set to BASE mode, REFCLKP/N[0] can be connected to REFCLKOP/N[0] or external reference clock source. When CKMODE is set to CDSR mode, REFCLKP/N[0] is un-used and REFCLKP/N[2:0] are connected to external reference clock sources which need belong to the same clock buffer.

The CLKREQ_L[0] is an upstream control signal that should be connected from the switch output with external pull-up to the CLKREQ_L pin on the host chip (Root Complex). The switch combines the CLKREQ_L[7:1] and drives the resulting signal out on the CLKREQ_L[0]. When endpoints do not have any packets to transmit, the switch and endpoints will not drive CLKREQ_L[7:1], CLKREQ_L[7:1] will be high due to external pull-up resistor and the reference clock REFCLKOP/N[7:1] for down ports will stop. Then, the switch does not drive the CLKREQ_L[0] low on its upstream port. If the Root Complex does not have any packets requiring transmission, it does not drive the CLKREQ_L[0] either. In this case, the CLKREQ_L[0] will be high due to external pull-up resistor to stop the reference clock source for the upstream port.

If desires to disable some specified Reference Clock Output Paris, it can be done by Port Clock Enable field in the Bifurcation Control Register (offset 55Ch. bit[31:24]) through I2C, SMBUS or EEPROM.

5.3 EEPROM Interface

The EEPROM interface consists of four pins: EECK (EEPROM clock), EEDI (EEPROM serial data input), EEDO (EEPROM serial data output) and EECS_L (EEPROM chip select). The Switch supports 2-, or 3-byte address SPI EEPROM parts and automatically determines the appropriate addressing mode. The EEPROM is used to initialize a number of registers before enumeration. This is accomplished after PERST_L is de-asserted, at which time the data from the EEPROM is loaded. The EEPROM interface is organized into a 16-bit base, and the Switch supplies an 8-bit EEPROM word address.

5.3.1 EEPROM ACCESS MODES

The Switch may access the EEPROM in a WORD format by either utilizing the auto mode through a hardware sequencer or interactive mode through the host configuration commands. For auto mode, it only happens during chip initialization after system reset (Please refer to 5.3.2 for more details). As to interactive mode, it allows to read/write data from/into the EEPROM by giving the command, address and data via EEPROM Control, address and data configuration registers at offset 30Ch and 310h.

5.3.2 EEPROM MODE AT RESET

During a reset, the Switch automatically loads the information/data from the EEPROM if the automatic load condition is met. The first offset in the EEPROM contains a signature. If the signature is recognized, the autoloading initiates right after the reset.

During the autoloading, the Switch will read sequential words from the EEPROM and write to the appropriate registers. Before the Switch registers can be accessed through the host, the autoloading condition should be verified by reading bit [4] offset [308h](#) (EEPROM Autoload Status). The host access is allowed only after the status of this bit is set to '1' which indicates that the autoloading initialization sequence is completed.

5.3.3 EEPROM SPACE ADDRESS MAP

Table 5-9 EEPROM Space Address Map

EEPROM Address	Value	Description
00h	1516h	EEPROM signature
02h	EEPROM_BYTE_SIZE	EEPROM size byte count
04h	CFG_PORT	1 st Configuration Port Address Bit[7:0]: port number Bit[15:8]: must fix to 00h
06h	CFG_OFFSET_ADDR	1 st Configuration Register Address Bit [9:0]: configuration register address Bit [15:10]: reserved
08h	CFG_LOW_DATA	1 st Configuration Register Data (low word)
0Ah	CFG_HIGH_DATA	1 st Configuration Register Data (high word)
0Ch	CFG_PORT	2 nd Configuration Port Address
0Eh	CFG_OFFSET_ADDR	2 nd Configuration Register Address
10h	CFG_LOW_DATA	2 nd Configuration Register Data (low word)
12h	CFG_HIGH_DATA	2 nd Configuration Register Data (high word)
...
FFF8h	CFG_HIGH_DATA	Last Configuration Register Data (high word)

5.4 SMBUS INTERFACE

The Packet Switch provides the System Management Bus (SMBus), a two-wire interface through which a simple device can communicate with the rest of the system. The SMBus interface on the Packet Switch is a bi-directional slave interface. It can receive data from the SMBus master or send data to the master. The interface allows full access to the configuration registers. A SMBus master, such as the processor or other SMBus devices, can read or write to every RW configuration register (read/write register). In addition, the RO and HwInt registers (read-only and hardware initialized registers) that can be auto-loaded by the EEPROM interface can also be read and written by the SMBus interface. This feature allows increases in the system expandability and flexibility in system implementation.

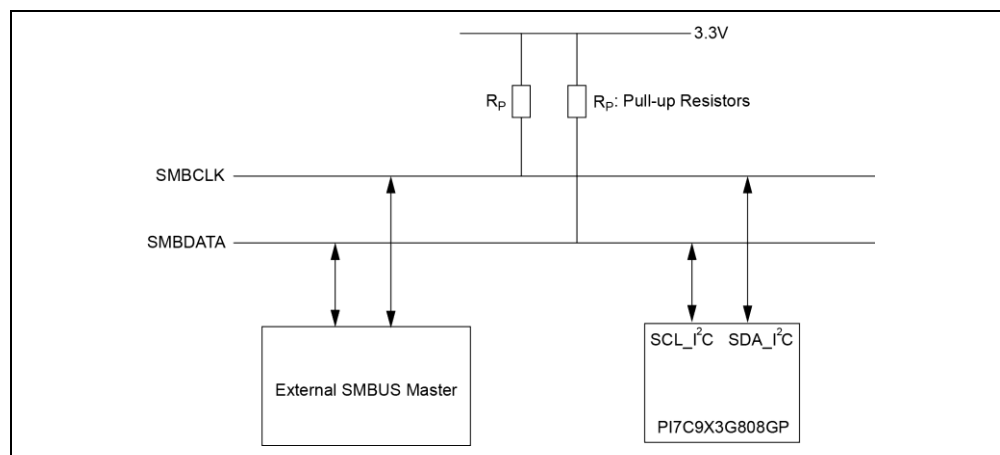

Figure 5-1 SMBus Architecture Implementation

The SMBus interface on the Packet Switch consists of one SMBus clock pin ([SCL_I2C](#)), a SMBus data pin ([SDA_I2C](#)), and 3 SMBus address pins ([I2C_ADDR\[2:0\]](#)). The SMBus clock pin provides or receives the clock signal. The SMBus data pin facilitates the data transmission and reception. Both of the clock and data pins are bi-directional. The SMBus address pins determine the address to which the Packet Switch responds to. The SMBus address pins generate addresses according to the following table:

Table 5-10 SMBUS Address Pin Configuration

BIT	SMBus Address
0	I2C_ADDR[0]
1	I2C_ADDR[1]
2	I2C_ADDR[2]
3	1
4	0
5	1
6	1

Software can change the SMBus Slave address, by programming the SMBus/I2C Control Register SMBus/I2C Device Address field.

The Switch also supports Packet Error Checking and Packet Error Code (PEC) generation, as explained in the SMBus v2.0.

The Switch supports three commands:

- Block Write (command BEh) is used to write CFG registers
- Block Write (command BAh), followed by Block Read (command BDh), is used to read CFG registers
- Block Read - Block Write Process Call (commands BAh, CDh) can also be used to read CFG registers

5.4.1 SMBUS BLOCK WRITE

The Block Write command is used to write to the Switch registers. General SMBus Block Writes are illustrated in Figure 5-2 and Figure 5-3. Table 5-11 explains the elements used in Figure 5-2 and Figure 5-3.

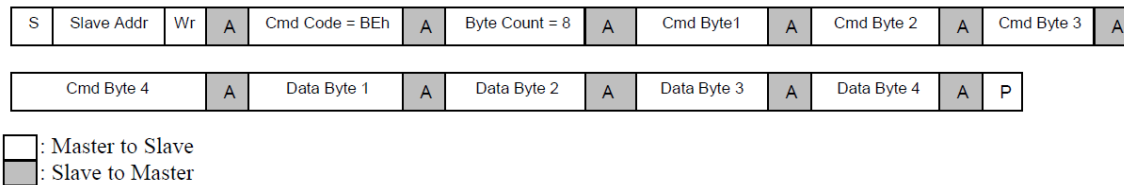

Figure 5-2 SMBus Block Write Command Format, to Write to a Switch Register without PEC

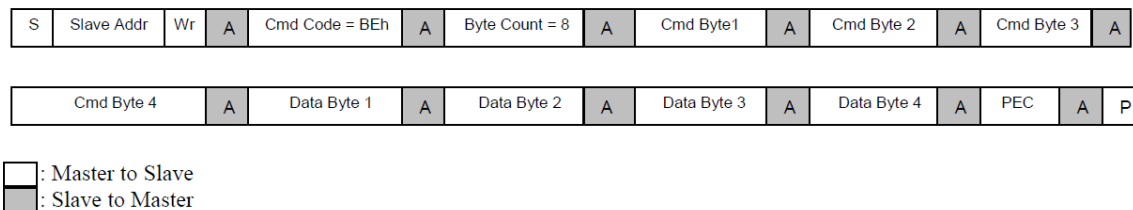

Figure 5-3 SMBus Block Write Command Format, to Write to a Switch Register with PEC

Block Write transactions that are received with incorrect Cmd Code are NACKed, starting from the wrong byte setting, and including subsequent bytes in the packet. For example, if the Byte Count value is not 8, the Switch NACKs the byte corresponding to the Byte Count value, as well as any Data bytes following within the same packet.

The byte after Data Byte 4, if present, is taken as the PEC byte, and if present, the PEC is checked. If a packet fails Packet Error Checking, the Switch drops the packet (ignores the Write), and returns NACK for the PEC byte, to the SMBus Master. Packet Error Checking can be disabled, by setting the SMBus/I²C Control Register PEC Check Disable bit. The Byte Count value, by definition, does not include the PEC byte.

Table 5-11 Bytes for SMBus Block Write

Field (Byte) On Bus	Bit(s)	Value/ Description										
S	1	START condition										
P	1	STOP condition										
A	1	Acknowledge (this bit position may be 0 for an ACK or 1 for a NACK)										
Command Code	7:0	BEh for Block Write										
Byte Count	7:0	08h = 8 bytes to follow (4 Command and 4 Data bytes). The PEC byte is not counted.										
Command Byte 1	7:3	Reserved										
	2:0	Command 011b = Write register 100b = Read register										
Command Byte 2	7	Reserved										
	6:4	Reserved. Must fix to 000b.										
	3:0	Port Select [4:1] 2 nd Command byte, bits [3:0], and 3 rd Command byte, bit 7, combine to form a 5-bit Port Select.										
Command Byte 3	7	Port Select [0] 2 nd Command byte, bits [3:0], and 3 rd Command byte, bit 7, combine to form a 5-bit Port Select. Port Select [4:0] is used to select Port to access.										
	6	Reserved										
	5:2	Byte Enable <table border="0"> <tr> <td>Bit</td> <td>Description</td> </tr> <tr> <td>2</td> <td>Byte Enable for Data Byte 4 (Switch register bits [7:0])</td> </tr> <tr> <td>3</td> <td>Byte Enable for Data Byte 3 (Switch register bits [15:8])</td> </tr> <tr> <td>4</td> <td>Byte Enable for Data Byte 2 (Switch register bits [23:16])</td> </tr> <tr> <td>5</td> <td>Byte Enable for Data Byte 1 (Switch register bits [31:24])</td> </tr> </table> 0 = Corresponding Switch register byte will not be modified 1 = Corresponding Switch register byte will be modified	Bit	Description	2	Byte Enable for Data Byte 4 (Switch register bits [7:0])	3	Byte Enable for Data Byte 3 (Switch register bits [15:8])	4	Byte Enable for Data Byte 2 (Switch register bits [23:16])	5	Byte Enable for Data Byte 1 (Switch register bits [31:24])
	Bit	Description										
2	Byte Enable for Data Byte 4 (Switch register bits [7:0])											
3	Byte Enable for Data Byte 3 (Switch register bits [15:8])											
4	Byte Enable for Data Byte 2 (Switch register bits [23:16])											
5	Byte Enable for Data Byte 1 (Switch register bits [31:24])											
1:0	Switch Register Address [11:10]											
Command Byte 4	7:0	Switch Register Address [9:2] Note: Address bits [1:0] are fixed to 0.										
Data Byte 1	7:0	Data write to register bits [31:24]										
Data Byte 2	7:0	Data write to register bits [23:16]										
Data Byte 3	7:0	Data write to register bits [15:8]										
Data Byte 4	7:0	Data write to register bits [7:0]										
PEC	7:0	Packet Error Code										

The table below is a sample to write SSID/SSVID register (offset [A8h](#)) in Port 1. The register value is 1234_5678h, with all bytes enabled, and without PEC. The default SMBus Address is 1101000b.

Table 5-12 Sample SMBus Block Write Byte Sequence

Byte Number	Byte Type	Value	Description
1	Address	D0h	Bits [7:1] for the Switch default Slave address of 68h, with bit 0 Cleared to indicate a Write.
2	Command Code	BEh	Command Code for register Write, using a Block Write
3	Byte Count	08h	Byte Count. Four Command Bytes and Four Data Bytes
4	Command Byte 1	03h	For Write command
5	Command Byte 2	00h	Bits [6:4] – must fix to 000b Bits [3:0] - Port Select [4:1] (for Port 1)

Byte Number	Byte Type	Value	Description
6	Command Byte 3	BCh	Bit 7 is Port Select[0] Bit 6 is reserved Bits [5:2] are the for Byte Enables; all are active Bits [1:0] are register Address bits [11:10]
7	Command Byte 4	2Ah	Switch Register Address bits [9:2] (for offset A8h)
8	Data Byte 1	12h	Data Byte for register bits [31:24]
9	Data Byte 2	34h	Data Byte for register bits [23:16]
10	Data Byte 3	56h	Data Byte for register bits [15:8]
11	Data Byte 4	78h	Data Byte for register bits[7:0]

5.4.2 SMBUS BLOCK READ

A Block Read command is used to read Switch CFG registers. Similar to CFG register Reads using I²C, a SMBus Write sequence must first be performed to select the register to read, followed by a SMBus Read of the corresponding register. There are two ways a Switch register can be read:

- Use a Block Write, followed by a Block Read. The Block Write sets up the parameters including Port Number, register address and Byte Enables, and the Block Read performs the actual Read operation.
- Use a Block Read - Block Write Process Call. This command is defined by the SMBus v2.0, and performs a Block Write and Block Read, using a single command. The Block Write portion of the message sets up the register to be read, and then a repeated START followed by the Block Read portion of the message returns the register data specified by the Block Write

The Switch always NACKs any incorrect command sequences, starting with the wrong Byte. Upon receiving the Block Read command, the Switch returns a PEC to the Master, if after the 4th byte of register data, the Master still requests one more Byte. As a Slave, the Switch recognizes the end of the Master's Read cycle, by observing the Master's NACK response for the last Data Byte transmitted by the Switch.

Incorrect command sequences are always NACK, starting with the byte that is incorrect. (Refer to Table 5-13.) On the Block Read command, a PEC is returned to the Master, if after the 4th byte of CSR data, the return Master still requests for one additional byte. As a Slave, the Switch will know the end of the Master Read cycle, by observing the NACK for the last byte read from the Master.

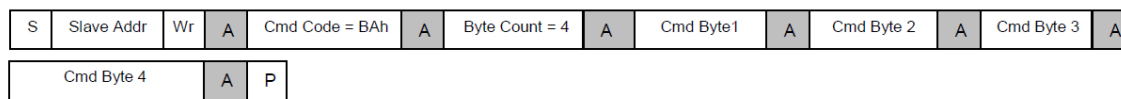

A Block Write to set up Read

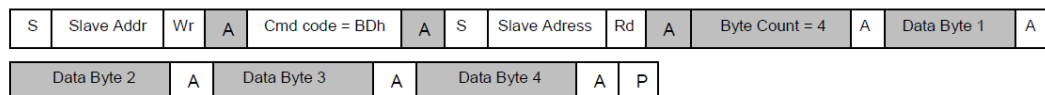

A Block Read which returns CFG Register Value

□ : Master to Slave
■ : Slave to Master

Figure 5-4 SMBus Block Write to Set up Read, and Resulting Read that Returns CFG Register Value

Table 5-13 Bytes for SMBus Block Read

Field (Byte) On Bus	Bit(s)	Value/Description
S	1	START condition
P	1	STOP condition

Field (Byte) On Bus	Bit(s)	Value/ Description										
A	1	Acknowledge (this bit position may be 0 for an ACK or 1 for a NACK)										
Command Code	7:0	BAh , to set up Read, using Block Writes										
Byte Count	7:0	04h , 4 Command bytes										
Command Byte 1	7:3	Reserved										
	2:0	Command 011b = Write register 100b = Read register										
Command Byte 2	7	Reserved										
	6:4	Reserved. Must fix to 000b.										
	3:0	Port Select [4:1] 2 nd Command byte, bits [3:0], and 3 rd Command byte, bit 7, combine to form a 5-bit Port Select.										
Command Byte 3	7	Port Select [0] 2 nd Command byte, bits [3:0], and 3 rd Command byte, bit 7, combine to form a 5-bit Port Select. Port Select [4:0] is used to select Port to access.										
	6	Reserved										
	5:2	Byte Enable <table border="1"> <thead> <tr> <th>Bit</th> <th>Description</th> </tr> </thead> <tbody> <tr> <td>2</td> <td>Byte Enable for Data Byte 4 (Switch register bits [7:0])</td> </tr> <tr> <td>3</td> <td>Byte Enable for Data Byte 3 (Switch register bits [15:8])</td> </tr> <tr> <td>4</td> <td>Byte Enable for Data Byte 2 (Switch register bits [23:16])</td> </tr> <tr> <td>5</td> <td>Byte Enable for Data Byte 1 (Switch register bits [31:24])</td> </tr> </tbody> </table> 0 = Corresponding Switch register byte will not be modified 1 = Corresponding Switch register byte will be modified	Bit	Description	2	Byte Enable for Data Byte 4 (Switch register bits [7:0])	3	Byte Enable for Data Byte 3 (Switch register bits [15:8])	4	Byte Enable for Data Byte 2 (Switch register bits [23:16])	5	Byte Enable for Data Byte 1 (Switch register bits [31:24])
	Bit	Description										
2	Byte Enable for Data Byte 4 (Switch register bits [7:0])											
3	Byte Enable for Data Byte 3 (Switch register bits [15:8])											
4	Byte Enable for Data Byte 2 (Switch register bits [23:16])											
5	Byte Enable for Data Byte 1 (Switch register bits [31:24])											
1:0	Switch Register Address [11:10]											
Command Byte 4	7:0	Switch Register Address [9:2] Note: Address bits [1:0] are fixed to 0.										
Command Code	7:0	BDh for Block Read										
Data Byte 1	7:0	Return value for CFG register bits [31:24]										
Data Byte 2	7:0	Return value for CFG register bits [23:16]										
Data Byte 3	7:0	Return value for CFG register bits [15:8]										
Data Byte 4	7:0	Return value for CFG register bits [7:0]										

Table 5-14, Table 5-15, Table 5-16 and Table 5-17 are a sample to Read SSID/SSVID register (offset [A8h](#)) in Port 1. The register value is 0000_0000h, with all bytes enabled, and without PEC. The default SMBus Address is 1101000b.

Table 5-14 SMBus Block Write Portion

Byte Number	Byte Type	Value	Description
1	Address	D0h	Bits [7:1] for the Switch default Slave address of 68h, with bit 0 Cleared to indicate a Write.
2	Command Code	BAh	Command Code for register Write, using a Block Write
3	Byte Count	04h	Byte Count. Four Command Bytes
4	Command Byte 1	04h	For Read command
5	Command Byte 2	00h	Bits [6:4] - must fix to 000b Bits [3:0] - Port Select [4:1] (for Port 1)
6	Command Byte 3	BCh	Bit 7 is Port Select[0] Bit 6 is reserved

Byte Number	Byte Type	Value	Description
			Bits [5:2] are the for Byte Enables; all are active Bits [1:0] are register Address bits [11:10]
7	Command Byte 4	2Ah	Switch Register Address bits [9:2] (for offset A8h)

Table 5-15 SMBus Block Read Portion

Byte Number	Byte Type	Value	Description
1	Address	D0h	Bits [7:1] value for the Switch Slave address of 68h, with bit 0 Cleared to indicate to indicate a Write.
2	Block Read Command Code	BDh	Command code for Block Read of Switch registers.

Table 5-16 SMBus Read Command following Repeat START from Master

Byte Number	Byte Type	Value	Description
1	Address	D1h	Bits [7:1] value for the Switch Slave address of 68h, with bit 0 Set to indicate a Read.

Table 5-17 SMBus Return Bytes

Byte Number	Byte Type	Value	Description
1	Byte Count	04h	Four Bytes in register
2	Data Byte 1	00h	Register data [31:24]
3	Data Byte 2	00h	Register data [23:16]
4	Data Byte 3	00h	Register data [15:8]
5	Data Byte 4	00h	Register data [7:0]

Table 5-18 SMBus Return Bytes

Field (Byte) On Bus	Bit(s)	Value/Description
Command Code	7:0	CDh for Block Read (Process Call Read)

5.4.3 CSR READ, USING SMBUS BLOCK READ – BLOCK WRITE PROCESS CALL

A general SMBus Block Read - Block Write Process Call sequence is illustrated in Figure 5-5. Alternatively, a general SMBus Block Read - Block Write Process Call with PEC sequence is illustrated in Figure 5-6

Using this command, the register to be read can be set up and read back with one SMBus cycle (a transaction with a START and ending in STOP). There is no STOP condition before the repeated START condition. The command format for the Block Write part of this command has the same sequence as in Table 5-14, except that the Command Code changes to CDh, as illustrated below. Other Bytes remain the same as used in the sequence for SMBus Block Write followed by Block Read. Table 5-18 lists the Command format for Block Read.

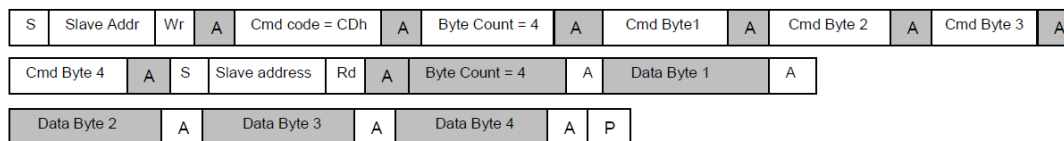

□ : Master to Slave
 ■ : Slave to Master

Figure 5-5 CSR Read Operation Using SMBus Block Read – Block Write Process Call

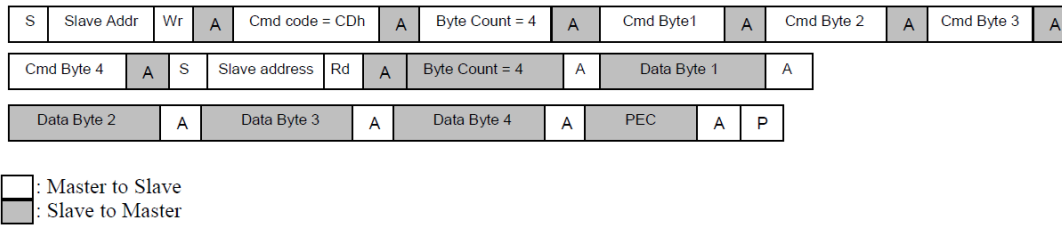

Figure 5-6 CSR Read Operation Using SMBus Block Read – Block Write Process Call with PEC

5.5 I2C Interface

Inter-Integrated Circuit (I²C) is a bus used to connect Integrated Circuits (ICs). Multiple ICs can be connected to an I²C Bus, and I²C devices that have I²C mastering capability can initiate a Data transfer. I²C is used for Data transfers between ICs at relatively low rates (100 Kbps), and is used in a variety of applications. For further details regarding I²C Buses, refer to the *I²C Bus v2.1*.

The Switch is an I²C Slave. Slave operations allow the Switch's Configuration Registers to be read from or written to by an I²C Master, external from the device. I²C is a sideband mechanism that allows the device Configuration registers to be programmed, read from, or written to, independent of the PCI Express upstream Link.

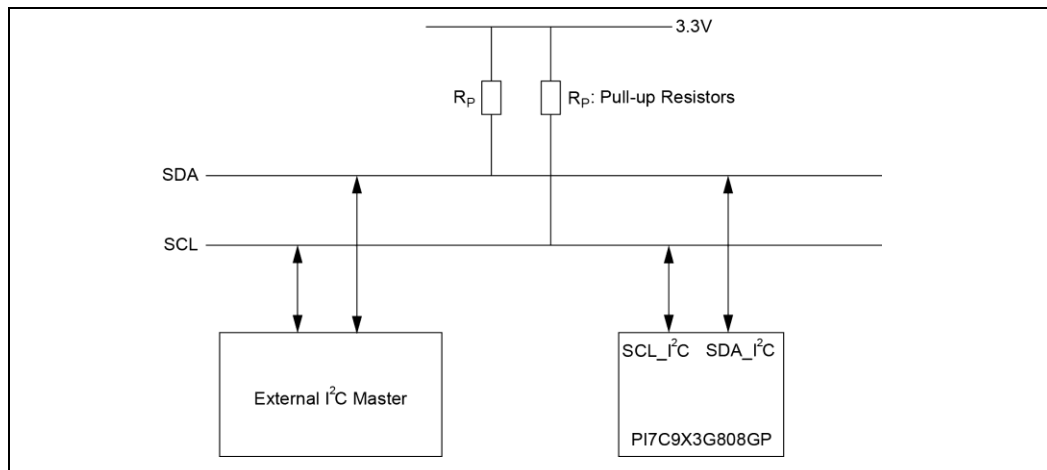

Figure 5-7 Standard Devices to I2C Bus Connection Block Diagram

The I²C interface on the Packet Switch consists of a I²C clock pin ([SCL_I2C](#)), a I²C data pin ([SDA_I2C](#)), and 3 I²C address pins ([I2C_ADDR\[2:0\]](#)). The I²C clock pin provides or receives the clock signal. The I²C data pin facilitates the data transmission and reception. Both of the clock and data pins are bi-directional. The I²C address pins determine the address to which the Packet Switch responds to. The I²C address pins generate addresses according to the following table:

Table 5-19 I²C Address Pin Configuration

BIT	I2C Address
0	I2C_ADDR[0]
1	I2C_ADDR[1]
2	I2C_ADDR[2]
3	1
4	0
5	1
6	1

Software can change the I²C Slave address, by programming the SMBus/I²C Control Register SMBus/I²C Device Address field.

5.5.1 I2C REGISTER WRITE ACCESS

The Switch Configuration registers can be read from and written to, based upon I²C register Read and Write operations, respectively. An I²C Write packet consists of Address Phase bytes and Command Phase bytes, followed by one to four additional I²C Data bytes. Table 5-18 defines mapping of the I²C Data bytes to the Configuration register Data bytes.

The I²C packet starts with the S (START condition) bit. Data bytes are separated by the A (Acknowledge Control Packet (ACK)) or N (Negative Acknowledge (NAK)) bit. The packet ends with the P (STOP condition) bit.

If the Master generates an invalid command, the targeted Switch register is not modified. The Switch considers the 1st Data byte of the 4-byte Data phase, following the four Command bytes in the Command phase, as register Byte 3 (bits [31:24]). The next three Data bytes access register Bytes 2 through 0, respectively. Four Data bytes are required, regardless of the Byte Enable Settings in the Command phase. The Master can then generate either a STOP condition (to finish the transfer) or a repeated START condition (to start a new transfer). If the I²C Master sends more than the four Data bytes (violating Switch protocol), further details regarding J2C protocol, the Switch returns a NAK for the extra Data byte(s).

Table 5-21 describes each I²C Command byte for Write access. In the packet described in Figure 5-8, Command Bytes 0 through 3 for Writes follow the format specified in Table 5-21.

Table 5-20 I2C Register Write Access

I2C Data Byte Order	PCI Express Configuration Register Byte
0	Written to register Byte 3
1	Written to register Byte 2
2	Written to register Byte 1
3	Written to register Byte 0

Table 5-21 I2C Command Format for Write Access

Byte	Bit(s)	Description										
1 st (0)	7:3	Reserved										
	2:0	Command 011b = Write register										
2 nd (1)	7	Reserved										
	6:4	Reserved. Must fix to 000b.										
	3:0	Port Select [4:1] 2 nd Command byte, bits [3:0], and 3 rd Command byte, bit 7, combine to form a 5-bit Port Select.										
3 rd (2)	7	Port Select [0] 2 nd Command byte, bits [3:0], and 3 rd Command byte, bit 7, combine to form a 5-bit Port Select. Port Select [4:0] is used to select Port to access.										
	6	Reserved										
	5:2	Byte Enable <table border="0"> <tr> <td>Bit</td> <td>Description</td> </tr> <tr> <td>2</td> <td>Byte Enable for Data Byte 4 (Switch register bits [7:0])</td> </tr> <tr> <td>3</td> <td>Byte Enable for Data Byte 3 (Switch register bits [15:8])</td> </tr> <tr> <td>4</td> <td>Byte Enable for Data Byte 2 (Switch register bits [23:16])</td> </tr> <tr> <td>5</td> <td>Byte Enable for Data Byte 1 (Switch register bits [31:24])</td> </tr> </table> 0 = Corresponding Switch register byte will not be modified 1 = Corresponding Switch register byte will be modified	Bit	Description	2	Byte Enable for Data Byte 4 (Switch register bits [7:0])	3	Byte Enable for Data Byte 3 (Switch register bits [15:8])	4	Byte Enable for Data Byte 2 (Switch register bits [23:16])	5	Byte Enable for Data Byte 1 (Switch register bits [31:24])
	Bit	Description										
2	Byte Enable for Data Byte 4 (Switch register bits [7:0])											
3	Byte Enable for Data Byte 3 (Switch register bits [15:8])											
4	Byte Enable for Data Byte 2 (Switch register bits [23:16])											
5	Byte Enable for Data Byte 1 (Switch register bits [31:24])											
1:0	Switch Register Address [11:10]											
4 th (3)	7:0	Switch Register Address [9:2] Note: Address bits [1:0] are fixed to 0.										

Figure 5-8 I2C Write Packet
I²C Write Packet Address Phase Byte

Address Cycle			
START	7654321	0	ACK/NAK
S	Slave Address [7:1]	Read/Write Bit 0 = Write	A

I2C Write Packet Command Phase Byte

Command Cycle							
76543210	ACK/NAK	76543210	ACK/NAK	76543210	ACK/NAK	76543210	ACK/NAK
Command Byte 0	A	Command Byte 1	A	Command Byte 2	A	Command Byte 3	A

I²C Write Packet Data Phase Byte

Write Cycle								
76543210	ACK/NAK	76543210	ACK/NAK	76543210	ACK/NAK	76543210	ACK/NAK	STOP
Register Byte 3	A	Register Byte 2	A	Register Byte 1	A	Register Byte 0	A	P

The following tables illustrate a sample I2C packet for writing the Switch SSID/SSVID register (offset [A8h](#)) for Port 0, with data 1234_5678h.

Note: The Switch has a default I²C Slave address [6:0] value of 68h, with the I2C_ADDR[2:0] input having a value of 000. The byte sequence on the I²C Bus, as listed in the following tables, occurs after the START and before the STOP bits, by which the I²C Master frames the transfer.

Figure 5-9 I2C Register Write Access Example
I²C Register Write Access Example – Address Cycle

Phase	Value	Description
Address	D0h	Bits [7:1] for Switch I ² C Slave Address (68h) with last bit (bit 0) for Write = 0

I²C Register Write Access Example – Command Cycle

Byte	Value	Description
0	03h	[7:3] Reserved [2:0] Command, 011b = Write register
1	00h for Port 0	[7] Reserved [6:4] must fix to 000b [3:0] Port Select[4:1]
2	3Ch for Port 0	[7] Port Select[0] [6] Reserved [5:2] Byte Enable, all active. [1:0] Switch Register Address, Bits [11:10]
3	2Ah	[7:0] Switch Register Address, Bits [9:2]

I²C Register Write Access Example – Data Cycle

Byte	Value	Description
0	12h	Data to Write for Byte 3
1	34h	Data to Write for Byte 2
2	56h	Data to Write for Byte 1
3	78h	Data to Write for Byte 0

Figure 5-10 I2C Write Command Packet Example
I²C Write Packet Address Phase Bytes

1 st Cycle			
START	7654321	0	ACK/NAK
S	Slave Address 1101_000b	Read/Write Bit 0 = Write	A

I²C Write Packet Command Phase Bytes

Command Cycle							
76543210	ACK/NAK	76543210	ACK/NAK	76543210	ACK/NAK	76543210	ACK/NAK
Command Byte 0 0000_0011b	A	Command Byte 1 0000_0000b	A	Command Byte 2 0011_1100b	A	Command Byte 3 0010_1010b	A

I²C Write Packet Data Phase Bytes

Write Cycle								
76543210	ACK/NAK	76543210	ACK/NAK	76543210	ACK/NAK	76543210	ACK/NAK	STOP
Register Byte 3	A	Register Byte 2	A	Register Byte 1	A	Register Byte 0	A	P

5.5.2 I2C REGISTER READ ACCESS

When the I²C Master attempts to read a Switch register, two packets are transmitted. The 1st packet consists of Address and Command Phase bytes to the Slave. The 2nd packet consists of Address and Data Phase bytes.

According to the I²C Bus, v2.1, a Read cycle is triggered when the Read/Write bit (bit 0) of the 1st cycle is Set. The Command phase reads the requested register content into the internal buffer. When the I²C Read access occurs, the internal buffer value is transferred on to the I²C Bus, starting from Byte 3 (bits [31: 24]), followed by the subsequent bytes, with Byte 0 (bits [7:0]) being transferred last. If the I²C Master requests more than four bytes, the Switch re-transmits the same byte sequence, starting from Byte 3 of the internal buffer.

The 1st and 2nd I²C Read packets perform the following functions:

- 1st packet - Selects the register to read
- 2nd packet - Reads the register (sample 2nd packet provided is for a 7-bit Switch I²C Slave address)

Although two packets are shown for the I²C Read, the I²C Master can merge the two packets together into a single packet, by not generating the STOP at the end of the first packet (Master does not relinquish the bus) and generating REPEAT START.

Table 5-22 describes each I²C Command byte for Read access. In the packet described in Figure 5-11, command Bytes 0 through 3 for Reads follow the format specified in Table 5-22.

Table 5-22 I²C Command Format for Read Access

Byte	Bit(s)	Description										
1 st (0)	7:3	Reserved										
	2:0	Command 100b = Read register										
2 nd (1)	7	Reserved										
	6:4	Reserved. Must fix to 000b.										
	3:0	Port Select [4:1] 2 nd Command byte, bits [3:0], and 3 rd Command byte, bit 7, combine to form a 5-bit Port Select.										
3 rd (2)	7	Port Select [0] 2 nd Command byte, bits [3:0], and 3 rd Command byte, bit 7, combine to form a 5-bit Port Select. Port Select [4:0] is used to select Port to access.										
	6	Reserved										
	5:2	Byte Enable										
		<table border="0"> <thead> <tr> <th>Bit</th> <th>Description</th> </tr> </thead> <tbody> <tr> <td>2</td> <td>Byte Enable for Data Byte 4 (Switch register bits [7:0])</td> </tr> <tr> <td>3</td> <td>Byte Enable for Data Byte 3 (Switch register bits [15:8])</td> </tr> <tr> <td>4</td> <td>Byte Enable for Data Byte 2 (Switch register bits [23:16])</td> </tr> <tr> <td>5</td> <td>Byte Enable for Data Byte 1 (Switch register bits [31:24])</td> </tr> </tbody> </table> <p>0 = Corresponding Switch register byte will not be modified 1 = Corresponding Switch register byte will be modified</p>	Bit	Description	2	Byte Enable for Data Byte 4 (Switch register bits [7:0])	3	Byte Enable for Data Byte 3 (Switch register bits [15:8])	4	Byte Enable for Data Byte 2 (Switch register bits [23:16])	5	Byte Enable for Data Byte 1 (Switch register bits [31:24])
	Bit	Description										
2	Byte Enable for Data Byte 4 (Switch register bits [7:0])											
3	Byte Enable for Data Byte 3 (Switch register bits [15:8])											
4	Byte Enable for Data Byte 2 (Switch register bits [23:16])											
5	Byte Enable for Data Byte 1 (Switch register bits [31:24])											
1:0	Switch Register Address [11:10]											

Byte	Bit(s)	Description
4 th (3)	7:0	Switch Register Address [9:2] Note: Address bits [1:0] are fixed to 0.

Figure 5-11 I2C Read Command Packet

I²C Read Command Packet Address Phase Byte (1st Packet)

1 st Cycle			
START	7654321	0	ACK/NAK
S	Slave Address[7:1]	Read/Write Bit 0 = Write	A

I²C Read Command Packet Command Phase Byte (1st Packet)

Write Cycle							
76543210	ACK/NAK	76543210	ACK/NAK	76543210	ACK/NAK	76543210	ACK/NAK
Command Byte 0	A	Command Byte 1	A	Command Byte 2	A	Command Byte 3	A

I²C Read Data Packet Address Phase Byte (2nd Packet)

1 st Cycle			
START	7654321	0	ACK/NAK
S	Slave Address[7:1]	Read/Write Bit 1 = Read	A

I²C Read Data Packet Data Phase Byte (2nd Packet)

Write Cycle								
76543210	ACK/NAK	76543210	ACK/NAK	76543210	ACK/NAK	76543210	ACK/NAK	STOP
Register Byte 3	A	Register Byte 2	A	Register Byte 1	A	Register Byte 0	A	P

The following tables illustrate a sample I2C packet for reading the Switch SSID/SSVID register (offset [A8h](#)) for Port 0. The default value for SSID/SSVID register is 0000_0000h.

Note: The Switch has a default I²C Slave address [6:0] value of 68h, with the I2C_ADDR[2:0] inputs having a value of 000. The byte sequence on the I²C Bus, as listed in the following tables, occurs after the START and before the STOP bits, by which the I²C Master frames the transfer.

Figure 5-12 I2C Register Read Access Example

I²C Register Read Access Example – Address Cycle (1st Packet)

Phase	Value	Description
Address	D0h	Bits [7:1] for Switch I ² C Slave Address (68h) with last bit (bit 0) for Write = 0

I²C Register Read Access Example – Command Cycle (1st Packet)

Byte	Value	Description
0	04h	[7:3] Reserved [2:0] Command, 100b = Read register
1	00h for Port 0	[7] Reserved [6:4] must fix to 000b [3:0] Port Select [4:1]
2	3Ch for Port 0	[7] Port Select [0] [6] Reserved [5:2] Byte Enable, All active. [1:0] Switch Register Address, Bits [11:10]
3	2Ah	[7:0] Switch Register Address, Bits [9:2]

I²C Register Read Access Example – 2nd Packet

Phase	Value	Description
Address	D1h	Bits [7:1] for Switch I2C Slave Address (68h) with last bit (bit 0) for Read = 1
Read	00h	Byte 3 of Register Read

Phase	Value	Description
	00h	Byte 2 of Register Read
	00h	Byte 1 of Register Read
	00h	Byte 0 of Register Read

Figure 5-13 I2C Read Command Packet

I²C Read Command Packet Address Phase Bytes (1st Packet)

1 st Cycle			
START	7654321	0	ACK/NAK
S	Slave Address 1101_000b	Read/Write Bit 0 = Write	A

I²C Read Command Packet Command Phase Bytes (1st Packet)

Command Cycle						
76543210	ACK/NAK	76543210	ACK/NAK	76543210	ACK/NAK	76543210
Command Byte 0 0000_0100b	A	Command Byte 1 0000_0000b	A	Command Byte 2 0011_1100b	A	Command Byte 3 0010_1010b

I²C Read Data Packet Address Phase Bytes (2nd Packet)

1 st Cycle			
START	7654321	0	ACK/NAK
S	Slave Address [7:1] 1101_000b	Read/Write Bit 1 = Read	A

I²C Read Data Packet Data Phase Bytes (2nd Packet)

Command Cycle							
76543210	ACK/NAK	76543210	ACK/NAK	76543210	ACK/NAK	76543210	Stop
Register Byte3 0000_0000b	A	Register Byte2 0000_0000b	A	Register Byte1 0000_0000b	A	Register Byte0 0000_0000b	P

6 HOT PLUG SUPPORT

The hot plug usages can be classified into surprised and managed types depending on the application scenario. Each type has two different control and status interfaces: serial and parallel. The switch implements both surprised/managed and serial/parallel hot-plug types in the downstream ports. The [HOT PLUG EN](#) strapping pin should be set to “1” to enable hot plug function in the downstream ports of the switch.

6.1 HOT PLUG TYPES

6.1.1 SURPRISED SERIAL HOT PLUG

If the device is inserted or removed asynchronously from downstream port, it is called surprised hot plug. When HOT_PLUG_TYPE strapping pin is set to “1”, the chip is operating under surprised hot plug mode.

- Hot Insertion Procedures:
 - Present Detect Pin (i.e. PDC_L[7:0]) is asserted
 - The corresponding “Presence Detect Change” and “Present Detect State” in slot status reflect the card is in the slot
 - Enable the corresponding reference clock output (i.e. REFCLKOP/N[7:0]) to the hot inserted device
 - Issue INTx Message or MSI to notify software processing hot plug event
 - Wait for 100ms and then deassert the corresponding downstream reset (i.e. HP_RST_L[7:0])
 - If DL_UP is set, then generating INTx Message or MSI to notify software initiating configuration cycles to the hot inserted device
- Hot Removal Procedures
 - The device is removed asynchronously or under abnormal condition (Ex. Human Error ...)
 - Either in-band or out-band Present Detect sensing device being removed
 - Commands LTSSM state machine to Detect.Quiet state
 - Upstream port replies UR status that any TLP being sent to this downstream port
 - Any packet stored in input queue of upstream port will be dropped silently
 - Assert Present detect change Interrupt to system software
 - Enable DPC trigger event and assert DPC interrupt and unmasked non-fatal message to system software
 - Turn off the corresponding output clock buffer and assert the corresponding hot plug reset signal

During power-up, the chip scans IO Expander like devices through I2C clock and data signals (i.e. SHCL_I2C and SHDA_I2C). According to the reference design described in LED management, one set of I2C bus serves 4 CPLD, which converts the serial bus into 8-bit parallel bus. The 8-bit mapping is defined in Table 6-1.

6.1.2 SURPRISED SERIAL HOT PLUG

If the device is inserted or removed asynchronously from downstream port, it is called surprised hot plug. When HOT_PLUG_TYPE strapping pin is set to “1”, the chip is operating under surprised hot plug mode.

- Hot Insertion Procedures:
 - Present Detect Pin (i.e. PDC_L[7:0]) is asserted
 - The corresponding “Presence Detect Change” and “Present Detect State” in slot status reflect the card is in the slot
 - Enable the corresponding reference clock output (i.e. REFCLKOP/N[7:0]) to the hot inserted device
 - Issue INTx Message or MSI to notify software processing hot plug event
 - Wait for 100ms and then deassert the corresponding downstream reset (i.e. HP_RST_L[7:0])

- If DL_UP is set, then generating INTx Message or MSI to notify software initiating configuration cycles to the hot inserted device
- Hot Removal Procedures
 - The device is removed asynchronously or under abnormal condition (Ex. Human Error ...)
 - Either in-band or out-band Present Detect sensing device being removed
 - Commands LTSSM state machine to Detect.Quiet state
 - Upstream port replies UR status that any TLP being sent to this downstream port
 - Any packet stored in input queue of upstream port will be dropped silently
 - Assert Present detect change Interrupt to system software
 - Enable DPC trigger event and assert DPC interrupt and unmasked non-fatal message to system software
 - Turn off the corresponding output clock buffer and assert the corresponding hot plug reset signal

During power-up, the chip scans IO Expander like devices through I2C clock and data signals (i.e. SHCL_I2C and SHDA_I2C). According to the reference design described in LED management, one set of I2C bus serves 4 CPLD, which converts the serial bus into 8-bit parallel bus. The 8-bit mapping is defined in Table 6-1.

Table 6-1 CPLD Signal Name Mapping for 8-bit IO Expander

BIT	DIRECTION	CPLD SIGNAL NAME
0	O	FAULT
1	O	LOCATE
2	N/A	Not used (Debug Only)
3	N/A	Not used (Debug Only)
4	I	PRSNT
5	N/A	Not used (Debug Only)
6	N/A	Not used (Debug Only)
7	N/A	Not used (Debug Only)

Among these signals, ATNLED and PWRLED defined in PCIe specification are repurposed to represent FAULT and LOCATE to be compliant with SFF-8489 for blinking LEDs. For details, please refer to LED Management specification.

The switch hot plug controller supports multiple I2C/SMBUS-like control interfaces. Each interface can serve up to 8 downstream ports. The I2C/SMBUS address for slave devices is started from 40h by default. In addition, this initial address is configurable through EEPROM to registers LTSSM/IOE CSR6 Bit[30] and LTSSM/IOE CSR7 Bit[6:0]. Each downstream port is correspondent to one equivalent 8-bit IO expander with the following Port/Address mapping table.

Table 6-2 Port/Address Mapping for 8-bit IO Expander

Downstream Port Number	P1	P2	P3	P4	P5	P6	P7	P8
Address	40h	41h	42h	43h	44h	45h	46h	47h

6.1.3 SURPRISED PARALLEL HOT PLUG

The parallel mode of Surprised Hot Plug is very similar to its serial mode except that no CPLD is required to control LED. Instead, the chip outputs LED signals (i.e. HP_LED [7:0]) to drive Amber LED directly and the blinking follows SFF-8489 IBPI specification.

6.1.4 MANAGED SERIAL HOT PLUG

If the device is inserted or removed synchronously with hot-plug management software from downstream port, it is called managed hot plug. When HOT_PLUG_TYPE strapping pin is set to “0”, the chip is operating under managed hot plug mode.

- Hot Insertion Procedures:
 - User inserts card
 - User closes MRL
 - User initiates hot-inserted sequence by pressing Attention Button
 - System commands slot control register to drive indicators and power on slot
 - System starts re-enumeration the hierarchy under the slot
- Hot Removal Procedures:
 - User initiates hot-removed sequence by pressing Attention Button
 - System informs application/driver to complete current task
 - System commands slot control register to drive indicators and power off slot
 - System disabled the hierarchy under the slot
 - User opens MRL and removes the card

During the process of hot insertion and removal, there are hot plug events corresponding to slot status bits ready for generation. When [Hot-Plug Interrupt Enable](#) bit is set, either MSI or INT message is issued to notify S/W for processing.

When power-up, the chip uses I2C clock and data signals to scan either 16-bit or 40-bit IO Expander dependent on the status of strapping pin (i.e. [IO_EXP_TYPE](#)). The IO Expander responds an interrupt (i.e. [HPCINT_L](#)) to notify any hot plug signal status change and the chip will read back the status change in serial mode and reflect on slot status register. The 16-bit mapping of managed hot plug events for I2C bit sequence is defined in Table 6-3

Table 6-3 CPLD Signal Name Mapping for 16-bit IO Expander

BIT	DIRECTION	CPLD SIGNAL NAME
0	O	PWRLED
1	O	ATNLED
2	O	PWREN
3	O	RECLKEN
4	O	PERST
5	O	INTERLOCK
6	N/A	N/A
7	I	SLOT#[0]
8	I	SLOT#[1]
9	I	SLOT#[2]
10	I	SLOT#[3]
11	I	PRSNT
12	I	MRL
13	I	ATNBTN
14	I	PWRFLT
15	I	PWRGOOD

Similar to Surprised Serial Hot Plug, each downstream port is correspondent to one equivalent 16-bit IO expander with the following Port/Address mapping table.

Table 6-4 Port/Address Mapping for 16-bit IO Expander

Downstream Port Number	P1	P2	P3	P4	P5	P6	P7	P8
Address	40h	42h	44h	46h	48h	4Ah	4Ch	4Eh

6.2 TIMING SEQUENCE FOR SURPRISED HOT PLUG OPERATION

Two timing charts are shown below to illustrate surprised hot insertion or removal under different scenarios. The first chart presents the timing relationship between system reset/reference_clock and individual downstream reset/reference_clock under initial power-up condition. The second chart demonstrates the timing sequence of clock and reset for device inserted or removed under power active condition.

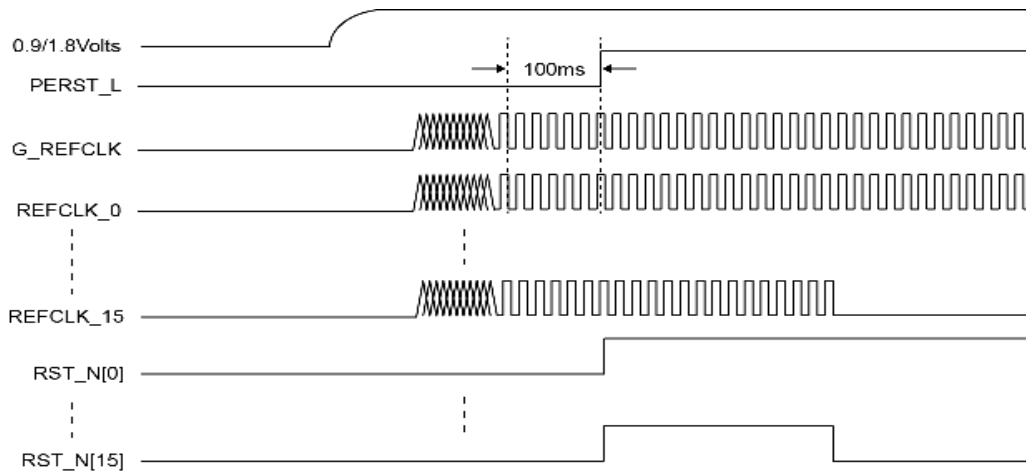

Note: There is a device in slot#0 while slot#15 is empty.

Figure 6-1 Timing Sequence for Surprised Hot Plug Operation

7 CROSS-DOMAIN END-POINT

7.1 GENERAL DESCRIPTION

The PCIe Packet Switch supports Cross-Domain End-Point (CDEP) function. The function, when working in conjunction with the software running on the PRIMARY HOST, enables data exchange among multiple PCIe-based hosts. This feature allows the system to implement fail-over or co-processor functionalities. These two use cases are briefly described in the following sections with the suitable CDEP Mode Switch Model for the use case.

7.1.1 FAIL-OVER

In an error resilient system, a back-up or secondary host is set up to take over the primary host in the event when primary has failed and the failure is detected. The CDEP Mode Switch Model facilitates the data exchange across domains of the primary and secondary hosts, and swaps the roles of the hosts in the event of the primary host's failure. The CDEP Mode Switch Model used in the fail-over use case is shown in the illustration below.

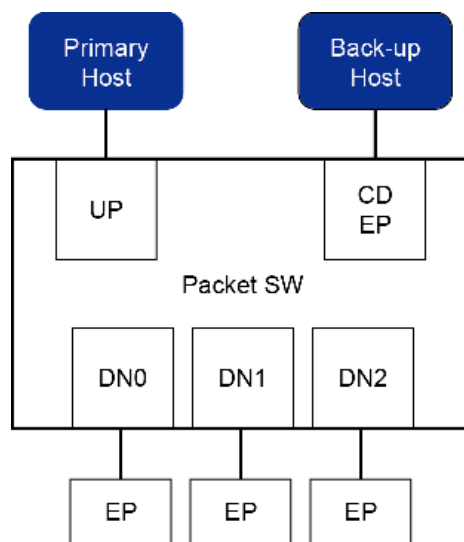

Figure 7-1 Switch Reference Model Used in the Fail-Over Use Case

In the event when the primary host is unable to send regular messages to the back-up host, the back-up host can swap its role to the primary host and its CDLEP port being an agent of upstream port to handle the traffic to/from downstream ports. The previous primary host's upstream port will be reset during the link-down process initiated by the previous primary host. The Switch has to ensure that the reset does not propagate to the entire upstream hierarchy in the previous primary host's, so that the new primary host can seamlessly manage the original End-Points. As a result, the impacts to the entire system are minimal during the fail-over transition.

7.1.2 CO-PROCESSOR

The co-processor can be connected to the CDLEP port to off-load the computation on the primary host. The illustration below shows a co-processor unit (CP), which works with the Primary Host to form a two-processor system. The DMA function of the PRIMARY HOST's upstream port is enabled to move data among the Primary Host and co-processor to accelerate intensive computation tasks.

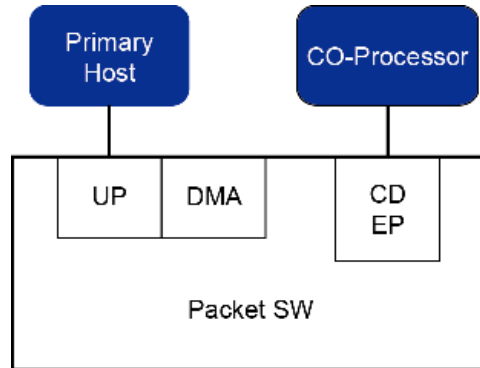

Figure 7-2 Switch Reference Model Used in the Co-Processor Use Case

7.2 PORT CONFIGURATION

The Primary Host can configure a Link CDEP port as a generic PCIe End-Point. This allows the secondary host(s) the ability to link to the switch CDEP port during PCIe enumeration. The enumeration process includes BIOS start-up, operating system start-up, and/or subsequent PCIe hot-plug or dynamic enumerations initiated by the host operating system.

Before the Primary Host can enable the CDEP function, the Switch has to be configured into the CDEP mode and designate the CDEP port to as the upstream port of a generic end-point. The configuration is performed through EEPROM programming at power-up. In order to operate in the CDEP mode, the Switch is required to set Chip CD Mode and Switch CD Mode for the CDEP port configurations. The Chip CD Mode and Switch CD Mode are defined in the Device Configuration 0 and 2 Registers respectively.

In order to support the CDEP mode, the Switch has to contain a Cross-Domain Virtual End-Point (CDVEP). The CDVEP acts as an agent to bridge the PRIMARY HOST and other host domain, and only exists in the Switch. In addition to the CDVEP, the Switch has another type of End-Point, called Cross-Domain Line End-Point (CDLEP). The CDLEP is visible to the Local Host (LH), but not the PRIMARY HOST. The CDLEP bridges the communications between the LH and other HOST. The table below describes the CDEP port's configurations by the Switch types.

Table 7-1 CDEP Mode Configuration

Switch CD Mode	CDEP Configuration
0x	Both CDEPs disabled
10	Illegal Configuration
11	CDVEP enabled, and CDLEP enabled

Only P4 can be designated as a CDLEP port. Once the port is chosen as CDLEP port, the port number defined in Link Capability Register and MMIO Register offsets will be changed accordingly. Please refer to the application note of CDEP operation for more information.

7.3 BAR TRANSLATION FOR LOCAL HOST DOMAIN

The PRIMARY HOST configures a set of CDEP Link address translations to the Switch. The translations allow the Local Host to access the CDEP Link's 64-bit BAR2/BAR3 and BAR4/BAR5 similar to accessing the other HOST locations. The PRIMARY HOST software is responsible for managing the memory regions appropriately to implement and emulate the CDLEP end-point behaviors.

The PRIMARY HOST defines either or both of a Direct Address Translation (DAT) range, and an Address Look-up Table (ALUT) for the BAR translations for the LH to access to other HOST memory locations. The PRIMARY HOST

configures these settings prior to enabling the CDLEP port. After the PRIMARY HOST programs the CDLEP port's BARs, the LH is able to read/write to the PRIMARY HOST or other LH memory locations.

7.3.1 DIRECT ADDRESS TRANSLATION (DAT)

The PRIMARY HOST arranges a contiguous memory block in the LH domain by setting BAR Configuration registers with the chosen DAT. The BAR2/BAR3 and BAR4/BAR5 have their own corresponding contiguous memory blocks. These memory blocks are characterized by the Base bits and Window Size bits. If the upper address of incoming TLP matches with the Base bits, the upper address will be replaced with the translated address stored in Base Translation Registers ([BTR2/BTR3](#) and [BTR4/BTR5](#)). The lower address bits are defined by the Window Size bits and remain intact. They are considered to be an offset address from the base address. The Window Size is determined by the BAR configuration, and the minimum size is 1MB.

7.3.2 ADDRESS LOOK-UP TRANSLATION (ALUT)

In addition to the Direct Address Translation, the BAR2/BAR3 provides an alternative address translation mechanism, Address Look-Up Translation (ALUT). The ALUT allows multiple translated address blocks in a non-contiguous address range. The Window Size bits defined earlier can be partitioned into 7 index bits and the rest lower address bits can form Page Size bits. The minimum page size is 8KB (1MB divided by 128). The 7 index bits are used to access 128 entries. Each entry represents a translated address block and the host domain destination it is associated with.

The ALUT Access Control Registers at offset from [918h](#) to [920h](#) in the CDLEP is used to store 128 entries. When performing ALUT entry write, the software has to program the ALUT data into the CDLEP at offset [91Ch](#) and [920h](#) if the translated address is 64-bit. The software then updates the index and Command (set to write) fields of the CDLEP at offset [918h](#). When performing LUT entry read, the software has to program index and Command (set to read) fields of the CDLEP at offset [918h](#), and then read [91Ch](#) and [920h](#) to get the LUT data.

7.3.3 ID TRANSLATION

In the event when a PCIe read or write is initiated in the LH PCIe domain, and the read/write targets the PRIMARY HOST memory or an end-point in the PRIMARY HOST PCIe domain, the PCIe Requestor ID field in the TLP header that targets the PRIMARY HOST must be *translated* into the PCIe Requestor ID of the CDVEP. This is to ensure that the IOMMU access permissions granted by the MPCU operating system, virtual machine, and/or end-point driver, apply to these translated TLPs. If the target is to another LH PCIe domain, the PCIe Requestor ID has to be translated into the PCIe Requestor ID of the destination CDLEP to ensure that a legal ID is used by the destination LH system.

7.4 BAR TRANSLATION FOR PRIMARY HOST DOMAIN

The PRIMARY HOST also configures a set of CDEP Virtual address translations. The address translations allow accesses to a defined address range to be translated to the LH memory addresses.

Similar to BAR Translation on the LH domain described previously, the BAR Translation on the PRIMARY HOST domain also supports two different approaches: the Direct Address Translation and the Address Look-Up table Translation. Please refer to the section of [CDVEP CONFIGURATION REGISTERS](#) for related BAR translation setup registers such as [BAR Configuration](#), [BTR](#), [ALUT Access Control](#), and more.

The RID translation in PRIMARY HOST domain is the same as the translation in the LH domain. The only difference is in building the RID LUT. However, the [RID table](#) is programmed by the PRIMARY HOST in the default setting, not by hardware automatically.

7.5 SCRATCHPADS AND DOORBELLS

The CDEP Link and virtual interfaces may provide a set of switch-specific scratchpad and doorbell registers for uses in Host-to-PRIMARY HOST/Host communication. By definition, custom driver or diagnostic code is required to run on the hosts. As a result, the PRIMARY HOST or Local Host must determine their visibility when a CDEP port emulates a generic End-Point. The registers must appear in PCIe configuration space in user-defined regions.

If the PRIMARY HOST intends to make the scratchpad and doorbell registers visible to the host, the PRIMARY HOST should define a CDEP Link property that enables a non-prefetchable 32-bit BAR0 containing these scratchpad and doorbell registers. A 4K range is allocated for CDLEP within the BAR0 at an offset address defined in the table in section 9.2.3 of the register reference document

In each CDLEP or CDVEP, there are 8 sets of 32-bit scratchpad registers (CDLEP at offset [9E4h~A00h](#), and CDVEP at offset [9E4h~A00h](#)), and one set of 32-bit doorbell registers (CDLEP offset [9C4h~9D0h](#) and CDVEP offset [9C4h~9D0h](#)). The scratchpad registers are used to store information for communication among Local Hosts and PRIMARY HOST. The doorbell registers are utilized to process (set/clear/mask/unmask) interrupt in order to notify the destination host to fetch the data stored in scratchpad registers of the source host. The scratchpad registers can only be written by the host in same domain while doorbell registers can be set/clear by both of hosts either in the same domain or in different domain. If the PRIMARY HOST uses the PCIe configuration command to access scratchpad and doorbell registers, it keep track of its End-Point-defined region and restrict its range so it does not go over the offset 9C4h. If the memory commands are used to access these registers in the CDLEP, the PRIMARY HOST has to enable a non-prefetchable 32-bit BAR3. A 4K range is allocated for CDLEP within the BAR0/1 at an offset address defined in the address table of Device Specific Memory Mapped Configuration Mechanism.

8 DIRECT MEMORY ACCESS

8.1 GENERAL DESCRIPTION

The Switch provides two DMA engines. These are hardware blocks that includes a set of buffers to asynchronously read and write to I/O memory through the Switch's ports. Each DMA engine is configured through a corresponding PCIe Function, managed by a software device driver running on a connected Local Host (LH) or Main Host (MH). The DMA engine is divided into single or multiple physical channels (2 per engine), providing a reserved portion of the buffer pool, and access to a set of virtual channels (2 per physical channel). The virtual channels allow the software initiator to submit lock-free requests, or partition access to the channel among a set of cooperating software subsystems. The initiator accesses the DMA engine using a physical/virtual channel (hereafter abbreviated as channel) to submit descriptors. Each descriptor tells the engine to read from a DMA source into one of the channel's internal buffers, and then performs a corresponding write to a DMA destination.

The Switch's DMA engines can be configured in a variety of ways, including:

- **Device Status Collection:** A host CPU can off-load blocking MMIO reads of device status registers to the DMA engine for asynchronous processing.
- **Peer-to-Peer EP Transfer:** A host CPU can off-load memory copies between a set of managed devices in the Switch.
- **Peer-to-Peer LH Transfer:** A set of cooperating LHs connected through a pair of [CDEP](#) ports can use the DMA Engine as a LH-to-LH memory transport, implementing a message queue.

In this section, any description of register layouts and data formats uses little-endian ordering.

8.2 DMA CONFIGURATION

The Switch's EEPROM or a micro-controller connected via I2C interface first configures the Switch's DMA engines (functions), enabling the DMA functions to appear underneath appropriate ports. Then, the software attaches a DMA driver to the DMA function based on the software model for the switch deployment to initialize and manage the set of channels (descriptor queues), start/stop/restart the channels, and perform appropriate error handling.

8.2.1 DMA FUNCTIONS

The Switch's EEPROM and switch configuration registers are set to indicate the ports under which the DMA functions will be visible to the connected LH or MH. This may include upstream ports, CDEP Link Ports, or virtual upstream ports.

The [Device Configuration #2 Register \(offset 50Ch\)](#) defined in upstream port (Port 0) is used to configure DMA function (bit[19:18]) under various CD modes (bit[17:16]) (Please refer to [CDEP chapter](#) for CD mode definition). The DMA mode definition is represented by the following table.

Table 8-1 DMA Mode definition

DMA Mode	DMA Configuration
0x	DMA functions disabled
10	DMA functions enabled for P0 or P4 based upon CD mode
11	DMA functions enabled for P0 only

8.2.1.1 DMA MODE BIT DEFINITION

- bit[1]: Decides if DMA function is enabled in the port connected to LH or MH.
0: DMA function is disabled
1: DMA function is enabled
- bit[0]: Determines if DMA function only visible to the MH's domain
0: DMA function is visible to its own local host or the MH's domain
1: DMA function is only visible to the MH's domain

8.2.1.2 DMA MODE AND CD MODE

DMA function is defined in the various ports under different CD and DMA mode settings. These ports are respectively “P0 port” and “CDLEP port”. A comprehensive table as shown below illustrates how the DMA functions (F1 or F2) being assigned to these three types of ports in terms of CD and DMA modes.

Table 8-2 DMA Function Definition in P0 and CDLEP Under Various Modes

CD Mode	DMA Mode	P0/F0	P0/F1/F2	P4/F0	P4/F1
00	00	Up-Port	N/A	Down-Port	N/A
00	01	Up-Port	N/A	Down-Port	N/A
00	10	Up-Port	2 DMAs	Down-Port	N/A
00	11	Up-Port	2 DMAs	Down-Port	N/A
01	00	Up-Port	N/A	Down-Port	N/A
01	01	Up-Port	N/A	Down-Port	N/A
01	10	Up-Port	2 DMAs	Down-Port	N/A
01	11	Up-Port	2 DMAs	Down-Port	N/A
11	00	Up-Port*	N/A	CDLEP	N/A
11	01	Up-Port*	N/A	CDLEP	N/A
11	10	Up-Port*	1 DMA	CDLEP	1 DMA
11	11	Up-Port*	2 DMAs	CDLEP	N/A

Note: Up-Port* means that CDLEP exists in the Up-Port host domain

8.2.1.3 ENUMERATION

The PCIe configuration space for each port that has been configured for DMA will enumerate one or more DMA Functions (Type 0 configuration space headers), with a well-defined vendor, device, and class code indicating DMA, and a set of control registers associated with a non-prefetchable BAR. Software will enumerate each DMA Function and program BARs. These configuration registers for [function #1 or function #2](#) is defined in the chapter 9 of this document.

8.2.2 DMA CONTROL REGISTER

DMA engine (i.e. function) provides [a set of interface registers](#) for software to control the operation and monitor the status of DMA transfer for all channels managed by this function. These registers are accessed by mmio via a base address defined in non-prefetchable BAR0 and BAR1 registers associated with the channel and individual register

offset defined in the section 5 of this document. For each channel, it will add an additional 100h offset to indicate the interface registers of one channel located in a 256-byte block. Hence, the access to one particular interface register in one of channels requires to set the address offset as follows: register offset + (number of channel) x 100h. Software can check the Channel ID field (bit[31:28]) of DMA Control and Status Register 0 at offset 00h to see if it is accessing the desired channel.

8.2.2.1 DMA DESCRIPTOR REGISTER

The DMA control register space will include a 64-bit pointer to the i/o address base of each channel's descriptor ring, and the size of the descriptor ring. Software will program the DMA registers to configure each descriptor ring, from which a channel will prefetch. The channel will support a total size for each descriptor ring of at most 4096 entries.

8.2.2.1.1 DESCRIPTOR POINTER REGISTER

The I/O address base of each channel's descriptor ring is pointed by a [64-bit channel descriptor ring base pointer at register offset 0Ch and 10h](#). The software has to program these registers, so the hardware can prefetch the descriptors starting from there.

8.2.2.1.2 DESCRIPTOR SIZE REGISTER

The size of descriptor ring can be programmed in [register offset 24h](#) (bit[12:0] in Channel Descriptor Ring Size for Prefetch register). The maximum descriptor ring size is 4096 entries. The bit[28:16] of this register indicates the next descriptor index is going to be prefetched.

8.2.2.2 DMA OPERATIONAL REGISTER

The DMA control register space will include a control register ([DMA Control and Status Register 1](#) at register offset 20h) for each channel to start, stop, abort, pause, and resume DMA activity for the channel. Software will update the control register to start the engine once it is ready to begin submitting requests. Software will update the control register if it needs to pause, stop, or otherwise reconfigure a channel.

After starting the DMA activity for that virtual channel (i.e. write "1" to bit[0] of DMA Control and Status Register 1), the software can update the control register any time by commanding the DMA engine to pause, abort or stop operation. Following is a summary for these three operations.

8.2.2.2.1 PAUSE (bit[1])

When set, the DMA activity is paused to the next active descriptor after completing the processing on current descriptor. Then, the DMA Pause Done status (bit[16]) is turned on to represent the DMA is in "paused" condition. If DMA Pause Interrupt Enable (bit[3]) is set, an interrupt will be issued to notify the software when bit[16] is set. For pause operation, there is no any descriptor or data being dropped and the DMA operation can be resumed any time by clearing the Pause Control (bit[1]).

8.2.2.2.2 ABORT (bit[2])

When set, the DMA activity drops the current active descriptor by flushing out all outstanding read commands and discarding all received completion data. The pointer will move to the next active descriptor. Then, the DMA Abort Done status (bit[17]) is turned on to represent the DMA is in "aborted" condition. If DMA Abort Interrupt Enable (bit[6]) is set, an interrupt will be issued to notify the software when bit[17] is set. In abort condition, the DMA operation can be resumed any time by clearing the Abort Control (bit[2]) and setting DMA Start (bit[0]). Then, DMA begins to process the next active descriptor. In fact, the software is also allowed to reprogram interface registers for re-initialization and start from the base descriptor pointer.

8.2.2.2.3 STOP (bit[7])

When set, the DMA activity drops the current active descriptor by flushing out all outstanding read commands and discarding all received completion data. The channel interface registers are all cleaned to default state except Interrupt flag bit if DMA stop enable is set earlier. Then, the DMA Stop Done status (bit[18]) is turned on to represent the DMA

is in “stopped” condition. If DMA Stop Interrupt Enable (bit[5]) is set, an interrupt will be issued to notify the software when bit[18] is set. In stop condition, the data buffer contents pointed by the previous processed descriptor will be dropped as well, so the software needs to reprogram interface registers for re-initialization before resuming DMA activity by setting DMA Start (bit[0]).

8.3 DMA DESCRIPTORS AND TRANSFERS

Each DMA channel will initiate descriptor pre-fetch when the channel is enabled and its ownership register is updated, indicating the valid range of descriptors to prefetch. When a valid descriptor is found, a DMA transfer will be scheduled with the underlying DMA engine in a fair manner with respect to other descriptors from other channels. The descriptor will be re-written by the DMA engine when the DMA transfer is complete, or if the DMA transfer fails due to an error. The switch will also update the ownership register to indicate the range of completed descriptors. Software will then examine the completed descriptors and take appropriate action.

8.3.1 DESCRIPTORS

Descriptors are located in the system memory. All of descriptors in a ring have to be concatenated together without gap (see figure 1. below). The switch will calculate the address offset automatically by adding the index of descriptor multiplied with the byte count of a single-descriptor to the ring base descriptor pointer for prefetch.

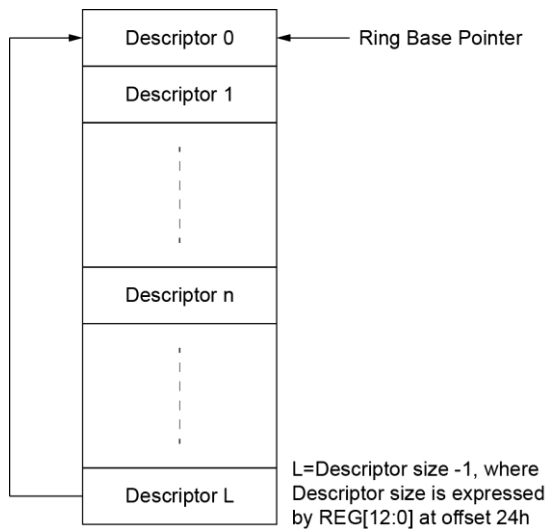

Figure 8-1 DMA Descriptor Map

8.3.1.1 INITIALIZATION

Software will initialize a valid descriptor by writing it to memory at the next free location in a channel’s descriptor ring. Software will ensure that the descriptor’s valid bit is written only after all other descriptor fields have been initialized. Software will update the ownership register to schedule execution of all initialized descriptors with the DMA engine.

8.3.1.2 OWNERSHIP

After all descriptor fields have been initialized, Software will update the ownership registers located at the register offset 04h and 08h by setting valid status. The [descriptor ownership 0 register](#) (04h) represents the first 32 descriptors’ valid status starting from bit[0] while the [descriptor ownership 1 register](#) (08h) stands for the next 32 descriptors’ valid status. The switch will pre-fetch the descriptors with valid status turned on continuously until the descriptor with valid

status being cleared. After the descriptors have been processed, the switch will update the ownership registers by clearing valid status in the order it was received.

8.3.1.3 PRE-FETCH

Software needs to update the Channel Descriptor Ring Size for [Pre-fetch register at offset 24h](#) by writing total descriptor numbers into bit[12:0]. Starting from the 1st descriptor pointed by ring base pointer register (0Ch and 10h), the descriptors will be pre-fetched by the switch continuously. The Channel Descriptor Current Pointer register at offset 14h indicates which descriptor is under processing. The switch will also take a residual function over the descriptor numbers divided by 64. If the remainder is less than or equal to 64, the switch will go back to prefetch the 1st descriptor after hitting the last descriptor.

When Software prepares to update the ownership registers during the DMA operation, it requires to check Descriptor current pointer (14h) viewed by the switch in order to update the correct 64-bit sliding window, which is advanced in terms of descriptor units.

8.3.2 TRANSFER

Software will define in the descriptor a 64-bit i/o source address, 64-bit i/o destination address, and transfer length up to 8MB. Switch will divide the DMA transfer into appropriate pairs of Memory Read and Write TLPs based on the current switch settings for [Max_Payload_Size](#) and [Max_Read_Request_Size](#), along with any 4k boundaries crossed by the range of addresses. Other than 64-bit i/o source and 64-bit i/o destination address, Software will also define 4-bit source domain and 4-bit destination domain in the descriptor for moving data across domains. Switch needs to generate Read or Write TLPs with a translated RID if the TLP destined domain is different from the domain where the DMA function is located.

8.3.2.1 LOCAL DOMAIN TRANSFER

For a local DMA transfer (i.e. no crossing host domains, the SDV and DDV must be “0” in the CTRL word of descriptors), the switch will refer to [Max Payload Size](#) and [Max Read Request Size](#) defined in PCIe configuration space in where the DMA function is resided for generating MRD and MWR TLPs along with any 4k boundaries crossed by the range of addresses.

8.3.2.2 CROSS DOMAIN TRANSFER

As to a cross-host-domain DMA transfer (i.e. either SDV or DDV or both are “0”), the switch will refer to [Max_Payload_Size](#) and [Max_Read_Request_Size](#) of other host domains defined in register offset [28h, 2Ch and 30h](#), which are usually programmed by Main Host. The switch will check the domain number carried in descriptor to choose the appropriate [Max_Payload_Size](#) and [Max_Read_Request_Size](#) for creating MRD and MWR TLPs. Please note that the Main Host software has to program the correct values of [Max_Payload_Size](#) and [Max_Read_Request_Size](#) for each domain by following the definition in PCIe configuration device control registers of that domain. Otherwise, it will cause undesired result in packet transfers.

As the DMA transfer source domain is different from destination domain, the Requester ID needs to be translated into a legal BDF ID of the destination domain. The software is required to program the captured bus number of CDV or CDL into domain bus number defined in register offset [34h, 38h and 3Ch](#). Regarding the captured bus number, the software can refer to CDEP data 0 register at offset A04h of CD port. The switch will check the domain number carried in descriptor to choose the appropriate bus number for creating RID of MRD and MWR TLPs.

8.3.3 DESCRIPTOR LAYOUT

The descriptor is formed by an 8-DW data block. The Figure 2 (see below) presents the layout of these DWs containing control word, source domain/address, destination domain/address, transfer byte count and others.

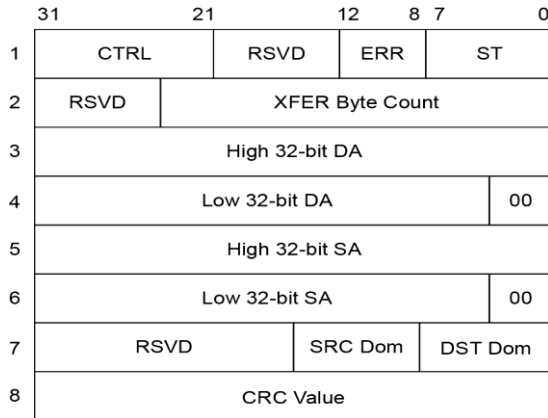

Figure 8-2 DMA Descriptor Layout in an 8-DW block

8.3.3.1 DOMAIN AND ADDRESS FIELD

The 64-bit I/O destination address and source address are located from the 3rd DW to 6th DW. They must be D-Word aligned. Also in the 7th DW, it defines the destination domain number (bit[7:0]) and source domain number (bit[15:8]) used for cross-domain DMA operation. Each domain number is expressed by LSB 2-bit that represents for 2 different host domain (0 ~ 1) supported by one packet switch. As to LSB 2-bit and MSB 4-bit, they are reserved for future use.

8.3.3.2 TRANSFER COUNT FIELD

The bit[22:0] in the 2nd DW stands for the transfer byte count for one descriptor can be up to 8MB.

8.3.3.3 CONTROL FILED

There are several bits defined in CTRL field of 1st DW for further formatting and enabling the source and destination locations. Please see Table 8-3 for illustrating bit definition in CTRL filed.

Table 8-3 Bit Definition in CTRL Field of the 1st DW

Bit	Name	Description
31	EOT	End of transfer
30	INT	Issue interrupt when DMA done
29	TPH	TPH function enable
28	NOP	No operation
27	FLH	Dlush any cached data
26	SAV	Source address is valid
25	DAV	Destination address is valid
24	64bit	Rnable 64 bit address
23	SAV	Source domain is valid
22	DDV	Destination domain is valid
21	CRC	Enable CRC checksum

- ◇ EOT(End of Transfer): Defined in bit[31]. When set, it indicates the current DMA transfer is completed. The interpretation on EOT is various for different DMA modes.
 - DMA mode bit[0]= 0: DMA processing is transferred from a source host domain to a destination host domain. In this condition, EOT bit will be set by software in the source descriptor when it is the last transfer. Once the destination DMA is notified by this event, the switch will set EOT bit in the destination descriptor and the transfer byte count will be updated as well. So the destination host would know the last transfer happening in this descriptor.
 - DMA mode bit[0]= 1: DMA processing is handled by the root host only. If the EOT valid bit defined in the DMA control register 0 is set, the switch will update the EOT bit in descriptor from 0 to 1 after transfer count indicated in descriptor is ended.

- ◇ 64bit: Defined in bit[24]. When set, the I/O address is in 64-bit physical memory. Otherwise, it is in 32-bit physical memory.
- ◇ SAV: Defined in bit[26]. When set, it means the I/O source address is valid. If cleared, the I/O source address is not valid, which is the condition that only destination DMA channel is enabled for executing host to host DMA.
- ◇ DAV: Defined in bit[25]. When set, it means the I/O destination address is valid. If cleared, the I/O destination address is not valid, which is the condition that only source DMA channel is enabled for executing host to host DMA.
- ◇ SDV: Defined in bit[23]. When set, it means the source domain number is valid and MRD will be issued to that domain by following its max payload size and read request size. It implies that DMA source and DMA function (or descriptors) are located in different domains. If cleared, it might be in the condition of either only DMA destination is positioned in a different domain from DMA function or just for a local (i.e. same domain) DMA transfer between source and destination.
- ◇ DDV: Defined in bit[22]. When set, it means the destination domain number is valid and MWR will be issued to that domain by following its max payload size. It implies that DMA destination and DMA function (or descriptors) are located in different domains. If cleared, it might be in the condition of either only DMA source is positioned in a different domain from DMA function or just for a local (i.e. same domain) DMA transfer between source and destination.
- ◇ NOP: Defined in bit[28]. Software can configure a no-op (zero length) descriptor by setting NOP of CTRL field. Once this bit is turned on, that performs no Reads or Writes. and
- ◇ FLH: Defined in bit[27]. Software can configure a cache flush descriptor by setting FLH of CTRL field. A cache flush descriptor, that forces the DMA engine to flush its buffer cache, and cancel any outstanding DMA Reads (thereby avoiding lengthy Completion Timeout conditions). Once this bit is turned on, the DMA activity drops the current active descriptor by flushing out all outstanding read commands and discarding all received completion data. The channel interface registers are all cleaned to default state as well. Software can check if DMA Start (bit[0] of register at offset 20h) is cleared to ensure “flush” event has completed. This “flush” feature provides a way for Software to restart DMA operation in terms of reinitializing the DMA ring buffer and interface registers.
- ◇ INT: Defined in bit[30]. Software may configure a descriptor with a flag (setting INT of CTRL field) to interrupt the software device driver on the completion (or failure) of the corresponding descriptor, using an interrupt mechanism defined by the containing DMA Function’s configuration registers. Software needs to clear the interrupt status by writing “1” to the bit[31] (Interrupt Flag) of register at offset 20h.
- ◇ In DMA Engine (Function) Configuration registers for function 1 or 2, it defines various interrupt mechanisms such as INTx Interrupt message enabled by bit[10] of command register at offset 04h (via configuration space), MSI/Multiple MSI enabled by bit[16]/bit[22:20] of MSI control register at offset 48h or MSI-X enabled by bit[31] of MSI-X control register at offset B0h.
- ◇ TPH: Defined in bit[29]. Software may configure a descriptor with a flag (setting TPH of CTRL field) to indicate that the posted memory writes issued by the DMA engine for this descriptor should include a set of TLP Processing Hints (TPH). The TPH will consist of setting the TH bit in each posted write’s TLP header, and incorporating an 8-bit ST (7:0) steering tag data field that is found in the DMA descriptor. The steering tag in the TLP header is copied from ST value defined in bit[7:0] of 1st DW in descriptor.

8.3.3.4 ERR FIELD

This 5-bit field can encode into 32 errors at most. In descriptor level, the DMA might detect the following errors such as Data Poison (encoded as 12, which is corresponding to bit[12] in AER), Completion Time-Out (bit[14]), Completer Abort (bit[15]), ECRC error (bit[19]) and Unsupported Request (bit[20]). If there are more than two errors (included) happening at the same time, it always reports the error defined with the least bit.

8.3.3.5 ST FIELD

It represents 8-bit steering tag. This 8-bit data is valid only when TPH bit set in control field.

8.3.3.6 CRC FIELD

Software may configure a descriptor with a flag to indicate that the DMA engine should compute a CRC-32 checksum of the data bytes (not including headers) that were read as part of the DMA transfer. The calculated CRC-32 will be written back to the descriptor on completion.

By setting CRC of CTRL field (bit[21] of the 1st DW), it enables DMA engine to compute a CRC-32 checksum over the raw data bytes of buffer pointed by the descriptor. It uses PCIe ECRC-32 polynomial and calculation is in a DW alignment. Upon the completion of descriptor processing, the final CRC-32 checksum result will be written back to the 8th DW of descriptor.

8.4 ERROR REPORTING AND HANDLING

The software managing a DMA function and associated channels must be able to define appropriate error handling behaviors for the DMA processing, including the handling of DMA memory read failures. To implement appropriate error handling for DMA:

8.4.1 ERROR REPORTING

Software will discover the Advanced Error Reporting (AER) capability in the configuration space of each DMA Function. Software will then enable AER, and configure the AERUCES, AERUCEM, AERUCESEV, AERCS, AERCEM, AERCC, AERHL, and AERTLP registers appropriately. The switch will update these registers and issue M_ERR messages as the DMA engine detects errors when processing a descriptor from the corresponding function. The switch will also rewrite the descriptor affected by an error with an error status field, indicating the corresponding PCIe error that caused the DMA to fail (e.g. DP, ECRC, CTO).

8.4.1.1 REPORTING VIA FUNCTION

In DMA Engine (Function) Configuration registers for function 1 or 2, it defines Advanced Error Reporting (AER) capability at byte offset 100h that followed by AERUCES, AERUCEM, AERUCESEV, AERCES, AERCEM, AERCC and AERHL registers from a byte offset 104h to 128h.

8.4.1.2 REPORTING VIA CHANNEL

When processing any descriptor in all of channels assigned to that DMA function, it will issue UCE_MSG if any of UCE is detected and also the corresponding UCE bit in AERUCEM is cleared. Meanwhile, the AERUCES would be copied to Channel UCES register defined in DMA interface register at offset 44h, so it will know which channel causing UCE. Furthermore, bit[25:24] of Channel UCES register will also indicate what type of DMA transaction running into Uncorrectable error. Bit[24] represents the detected error happening in fetching descriptor while bit[25] shows that error detected in reading data into DMA buffer. The DMA engine will issue interrupt if UCE Interrupt Enable bit (bit[17] of DMA Control and Status 0) is turned on.

8.4.1.3 REPORTING VIA DESCRIPTOR

To continuously trace down from where the UCE is coming, the DMA engine will also write back the error status to the descriptor which is affected by an error with a 5-bit error status field (bit[12:7] of 1st DW in descriptor). A 5-bit error status field can represent any of the PCIe UEs defined in AERUCES (e.g. error field=12 in descriptor would mean DP because DP is the 12th bit of AERUCES). Once Multiple UEs happen simultaneously, the lowest bit position in AERUCES will be recorded. (e.g. if DP (bit[12] in AERUCES) and Malformed TLP (bit[18] in AERUCES) are detected, only the DP reported as error since it is a lowest bit)

8.4.2 ERROR LOGGING

The DMA Function will provide a default (or configurable) value for AERCAP + 18h AERCC.MHRC, and errors will be logged appropriately into AERHL and AERTLP as detected when processing a descriptor from the corresponding function. The default value for AERCC.MHRC is zero, so there is only one TLP header with error(s) will be logged into AERHL.

8.4.3 DATA INTEGRITY

The switch will implement ECRC checking and ECRC generation for TLPs passing through the DMA engine. As such, the DMA Function will set AERCC.ECC=1 and AEREGC=1 in the AER capability, DMA Reads will verify ECRC, and DMA Writes will generate ECRC.

In AERCC register of DMA function configuration space, it defines ECC (bit[7]) and EGC (bit[5]) as “1” so the system software can set ECE = 1 (bit[8]) and EGE = 1 (bit[6]) to enable the switch to perform ECRC checking and ECRC generation for TLPs passing through the DMA engine.

8.4.4 ERROR HANDLING FOR UNCORRECTABLE ERROR DETECTED

The switch will provide software the channel status to determine whether a particular detected error will automatically stop the channel, or simply mark the descriptor as being in error, and continue processing the next descriptor. Once detecting uncorrectable error, the DMA will write back error status into the descriptor which is affected by error(s). Also, the switch will take the following steps for two scenarios.

8.4.4.1 ERROR IN DATA BUFFER

If the error occurs in the TLPs that are CPLDs for storing into DMA data buffer, the DMA activity drops the current active descriptor by flushing out all outstanding read commands and discarding all received completion data. The pointer will move to the next active descriptor and this would be treated like an H/W abort event. This channel is aborted and it is up to Software to restart DMA from the next descriptor or re-program the DMA control register to start from the base descriptor.

8.4.4.2 ERROR IN DESCRIPTOR

If the error occurs in the TLPs that are CPLDs for storing into Prefetch descriptor cache, the DMA activity not only drops the current active descriptor by flushing out all outstanding read commands and discarding all received completion data, but also dumps the following descriptors since they are damaged as well. So this channel is stopped and requires Software to reprogram interface registers for re-initialization before resuming DMA activity by setting DMA Start (bit[0]).

8.4.5 ERROR HANDLING FOR DMA READ

The switch will provide a register for the DMA function that software can use to determine whether an error on DMA Memory Read will cause the function and/or descriptor to report an error immediately (without writing), or will cause the function and/or descriptor to report an error only after writing to the DMA destination address a Poisoned (DP) Memory Write TLP for each corresponding Memory Read that failed.

If the UCE occurring in DMA read for CPLDs acquired from source address, the error report scheme (bit[18] in DMA Control and Status Register 0) can be configured in two different modes.

- ◇ If bit[18] is set, DMA reports UCE event after writing DP TLP to destination address. The DP TLP is generated for each corresponding memory read that failed.
- ◇ If bit[18] is cleared, DMA reports UCE event immediately without writing DP TLP to destination address.

9 REGISTER DESCRIPTION

9.1 REGISTER TYPES

This chapter details the Packet Switch registers, including

- Bit names
- Description of register functions
- Type, refer to Table 9-1
- Whether the default value can be modified by EEPROM and/or I2C/SMBUS
- Default value

Table 9-1 Register Types

REGISTER TYPE	DEFINITION
RO	Read Only
RW	Read / Write
RWIC	Read / Write 1 to Clear
RWIO	Read/Write 1 Only
RsvdP	RO and must return 0 when read.

9.2 REGISTER ACCESS

Each Switch Port implements a 4-KB Configuration Space which includes the lower 256 bytes PCI-compatible Configuration Space, and the upper 3840 bytes PCI Express Extended Configuration Space. There are several mechanisms that can access the Configuration Space:

- PCI-compatible Configuration Mechanism
- PCI Express Enhanced Configuration Access Mechanism
- Device-specific Memory Mapped Configuration Mechanism
- I2C Slave Interface
- SMBUS Slave Interface

9.2.1 PCI-COMPATIBLE CONFIGURATION MECHANISM

The PCI-compatible Configuration Mechanism provides standard access to the first 256 bytes of the PCI Express Configuration Space. The mechanism uses PCI Type 0 and Type 1 Configuration transactions to access the Packet Switch Configuration registers.

9.2.2 PCI EXPRESS ENHANCED CONFIGURATION ACCESS MECHANISM

The PCI Express Enhanced Configuration Access Mechanism is implemented on all PCI Express PCs. It provides a memory-mapped address space in the root complex, through which the root complex translates a memory access into one or more configuration requests. Device drivers normally use an application programming interface (API) provided by the Operating System (OS) to use this mechanism. The mechanism can access all Packet Switch registers.

9.2.3 DEVICE-SPECIFIC MEMORY MAPPED CONFIGURATION MECHANISM

The Device-Specific memory-Mapped Configuration Mechanism provides a method to access the configuration registers of all ports in a single 512KB memory map. The registers of each port are contained within a 4-KB range.

To use this mechanism, BIOS/OS needs to set BAR 0 and BAR 1 registers of up port at boot time. After BAR 0 and BAR 1 are enumerated, Port 0 registers can be access with Memory Reads from and Writes to the first 4 KB, Port 1 registers can be accessed with Memory Reads from and Writes to the 2nd , and so forth.

Physical Location Index	Port Number	BAR 0/1 Offset
Port 0	0000_0000b	0_0000h
Port 1	0000_0001b	0_1000h
...
Port 7	0000_0111b	0_7000h
CDEP 1	1001_0000b	7_0000h
CQ Header Location	N/A	6_F000h

Note: “Port Number” is defined in link capabilities register (offset 74h) bit[31:24].

9.3 TRANSPARENT MODE CONFIGURATION REGISTERS

When the port of the Switch is set to operate at the transparent mode, it is represented by a logical PCI-to-PCI Bridge that implements type 1 configuration space header. The following table details the allocation of the register fields of the PCI 2.3 compatible type 1 configuration space header.

31 – 24	23 – 16	15 – 8	7 – 0	BYTE OFFSET
Device ID		Vendor ID		00h
Primary Status		Command		04h
Class Code		Revision ID		08h
Reserved	Header Type	Primary Latency Timer	Cache Line Size	0Ch
Base Address 0 (Upstream Port Only)				10h
Base Address 1 (Upstream Port Only)				14h
Secondary Latency Timer	Subordinate Bus Number	Secondary Bus Number	Primary Bus Number	18h
Secondary Status		I/O Limit Address	I/O Base Address	1Ch
Memory Limit Address		Memory Base Address		20h
Prefetchable Memory Limit Address		Prefetchable Memory Base Address		24h
Prefetchable Memory Base Address Upper 32-bit				28h
Prefetchable Memory Limit Address Upper 32-bit				2Ch
I/O Limit Address Upper 16-bit		I/O Base Address Upper 16-bit		30h
Reserved			Capability Pointer to 40h	34h
Reserved				38h
Bridge Control		Interrupt Pin	Interrupt Line	3Ch
Power Management Capabilities		Next Item Pointer=48h	Capability ID=01h	40h
PM Data	PPB Support Extensions	Power Management Data		44h
Message Control		Next Item Pointer=68h	Capability ID=05h	48h
Message Address				4Ch
Message Upper Address				50h
Reserved		Message Data		54h
MSI Mask				58h
MSI Pending				5Ch
Reserved				60h – 64h
PCI Express Capabilities Register		Next Item Pointer=A4h	Capability ID=10h	68h
Device Capabilities				6Ch
Device Status		Device Control		70h
Link Status		Link Control		74h
Slot Status		Slot Control		78h
Slot Capabilities				7Ch
Slot Capabilities				7Ch
Slot Status		Slot Control		80h
Reserved				84h – 88h
Device Capabilities 2				8Ch
Device Status 2		Device Control 2		90h
Link Status 2		Link Control 2		94h
Slot Status 2		Slot Control 2		98h
Slot Capabilities 2				9Ch
Slot Capabilities 2				9Ch
Slot Status 2		Slot Control 2		A0h
Reserved		Next Item Pointer= B0h (Up) 00h (Down)	SSID/SSVID Capability ID=0Dh	A4h
SSID		SSVID		A8h
Reserved				ACh
MSI-X Control		Next Item Pointer=00h	MSI-X Capability ID=11h	B0h
MSI-X Table Offset / Table BIR				B4h
MSI-X PBA Offset / PBA BIR				B8h
Reserved				BCh - DCh
BAR 0 Configuration (Upstream Port Only)				E0h
BAR 0-1 Configuration (Upstream Port Only)				E4h
Reserved				E8h - FCh

Other than the PCI 2.3 compatible configuration space header, the Switch also implements PCI express extended configuration space header, which includes advanced error reporting, virtual channel, and power budgeting capability

registers. The following table details the allocation of the register fields of PCI express extended capability space header. The first extended capability always begins at offset 100h with a PCI Express Enhanced Capability header and the rest of capabilities are located at an offset greater than 0FFh relative to the beginning of PCI compatible configuration space.

31 - 24	23 - 16	15 - 8	7 - 0	BYTE OFFSET
Next Capability Offset=130h	Cap. Version	PCI Express Extended Capability ID=0001h		100h
Uncorrectable Error Status				104h
Uncorrectable Error Mask				108h
Uncorrectable Error Severity				10Ch
Correctable Error Status				110h
Correctable Error Mask				114h
Advanced Error Capabilities and Control				118h
Header Log Register 0				11Ch
Header Log Register 1				120h
Header Log Register 2				124h
Header Log Register 3				128h
Reserved				12Ch
Next Capability Offset=1A0	Cap. Version	PCI Express Extended Capability ID=0002h		130h
Port VC Capability Register 1				134h
VC Arbitration Table Offset=4h	Port VC Capability Register 2			138h
Port VC Status		Port VC Control		13Ch
Port Arbitration Table Offset=5h	VC Resource Capability Register (0)			140h
VC Resource Control Register (0)				144h
VC Resource Status Register (0)		Reserved		148h
Reserved				14Ch - 19Ch
Next Capability Offset=1B0h (Up) 1C0h (Down)	Cap. Version	PCI Express Extended Capability ID=0003h		1A0h
Serial Number Lower DW				1A4h
Serial Number Upper DW				1A8h
Reserved				1ACh
Next Capability Offset=1D0h	Cap. Version	PCI Express Extended Capability ID=0004h		1B0h
Reserved		Data Select		1B4h
Power Budgeting Data				1B8h
Reserved		Power Budget Capability		1BCh
Next Capability Offset=1D0h	Cap. Version	PCI Express Extended Capability ID=000Dh		1C0h
ACS Capability				1C4h
Reserved		Egress Control Vector		1C8h
Reserved				1CCh
Next Capability Offset=200h (Up) 210h (Down)	Cap. Version	PCI Express Extended Capability ID=0012h		1D0h
Multi-Case Control		Multi-Case Capability		1D4h
Multi-Case Base Address 0				1D8h
Multi-Case Base Address 1				1DCh
Multi-Case Receive				1E0h
Multi-Case Receive Upper 32-Bits				1E4h
Multi-Case Block All				1E8h
Multi-Case Block All 32-Bits				1ECh
Multi-Case Block Untranslated				1F0h
Multi-Case Block Untranslated 32-Bits				1F4h
Reserved				1F8h - 1FCh
Next Capability Offset=210h	Cap. Version	PCI Express Extended Capability ID=0018h		200h
Max. No-Snoop Latency		Max. Snoop Latency		204h
Reserved				208h - 20Ch

31 - 24	23 - 16	15 - 8	7 - 0	BYTE OFFSET
Next Capability Offset=2B0h (Up) 2A0h (Down)	Cap. Version	PCI Express Extended Capability ID=0019h		210h
Link Control 3				214h
Lane Error Status				218h
Lane 1 Equalization Control		Lane 0 Equalization Control		21Ch
Lane 3 Equalization Control		Lane 2 Equalization Control		220h
Reserved		Reserved		224h
Reserved		Reserved		228h
Lane 5 Equalization Control		Lane 4 Equalization Control		22Ch
Lane 7 Equalization Control		Lane 6 Equalization Control		230h
Reserved		Reserved		234h
Reserved		Reserved		238h
Reserved				23Ch - 29Ch
Next Capability Offset=2B0h	Cap. Version	PCI Express Extended Capability ID=001Dh		2A0h
DPC Control		DPC Capability		2A4h
DPC Error Source ID		DPC Status		2A8h
Reserved				2ACh
Next Capability Offset=300h	Cap. Version	PCI Express Extended Capability ID=001Eh		2B0h
L1 PM Substates Capability				2B4h
L1 PM Substates Control 1				2B8h
L1 PM Substates Control 2				2BCh
Reserved				2C0h - 2FCh
Next Capability Offset=000h	Cap. Version	PCI Express Extended Capability ID=000Bh		300h
Vendor-Specific Length	Revision	Vendor-Specific ID		304h
EEPROM Control (Upstream Port Only)				308h
EEPROM Address and Data (Upstream Port Only)				30Ch
Debug Control (Port 0 Only)				310h
Debug Data (Port 0 Only)				314h
SMBUS Control and Status (Port 0 Only)				318h
GPIO 0-15 Direction Control (Port 0 Only)				31Ch
GPIO 16-31 Direction Control (Port 0 Only)				320h
GPIO Input De-bounce (Port 0 Only)				324h
GPIO 0-15 Input Data (Port 0 Only)				328h
GPIO 16-31 Input Data (Port 0 Only)				32Ch
GPIO 0-15 Output Data (Port 0 Only)				330h
GPIO 16-31 Output Data (Port 0 Only)				334h
GPIO 0-31 Interrupt Polarity (Port 0 Only)				338h
GPIO 0-31 Interrupt Status				33Ch
GPIO 0-31 Interrupt Mask				340h
Reserved				344h
Operation Mode (Port 0 Only)				348h
Clock Buffer Control (Port 0 Only)				34Ch
Reserved				350h - 37Ch
LTSSM CSR 0				380h
LTSSM CSR 1				384h
LTSSM CSR 2				388h
LTSSM CSR 3				38Ch
LTSSM 0				390h
LTSSM 1				394h
LTSSM 2				398h
LTSSM 3				39Ch
LTSSM 4				3A0h
LTSSM 5				3A4h
LTSSM 6				3A8h
LTSSM 7				3ACh
LTSSM 8				3B0h
LTSSM 9				3B4h
LTSSM 10				3B8h
LTSSM 11				3BCh
LTSSM 12				3C0h
LTSSM 13				3C4h

31 -24	23 - 16	15 - 8	7 -0	BYTE OFFSET
		LTSSM 14		3C8h
		LTSSM 15		3CCh
		Reserved		3D0h ~ 41Ch
		DLL CSR 0		420h
		DLL CSR 1		424h
		DLL CSR 2		428h
		DLL CSR 3		42Ch
		DLL CSR 4		430h
		DLL CSR 5		434h
		DLL CSR 6		438h
		DLL CSR 7		43Ch
		DLL CSR 8		440h
		DLL CSR 9		444h
		DLL CSR 10		448h
		DLL CSR 11		44Ch
		DLL CSR 12		450h
		DLL CSR 13		454h
		DLL CSR 14		458h
		DLL CSR 15		45Ch
		DLL CSR 16		460h
		DLL CSR 17		464h
		DLL CSR 18		468h
		DLL CSR 19		46Ch
		LA Debug		470h
		Reserved		474h ~ 4BCh
		TL CSR 0		4C0h
		TL CSR 1		4C4h
		TL CSR 2		4C8h
		TL CSR 3 (Port 0 Only)		4CCCh
		TL CSR 4		4D0h
		Reserved		4D4h ~ 500h
		Device Configuration 0 (Port 0 Only)		504h
		Device Configuration 1 (Port 0 Only)		508h
		Device Configuration 2 (Port 0 Only)		50Ch
		Device Clock External Control (Port 0 Only)		510h
		Device SRIS Mode External Control (Port 0 Only)		514h
		Device COMM Refclk Mode External Control (Port 0 Only)		518h
		MBIST CFG Control (Port 0 Only)		51Ch
		MBIST CFG Status (Port 0 Only)		520h
		NOC BIST Control and Status (Port 0 Only)		524h
		External Loopback PRBS Control (Port 0 Only)		528h
		PHY SRAM Program 0 (Port 0 Only)		52Ch
		PHY SRAM Program 1 (Port 0 Only)		530h
		Failover Control (Port 0 Only)		534h
		Thermal Sensor INT Mask and Status (Port 0 Only)		538h
		Thermal Sensor Control (Port 0 Only)		53Ch
		Device Elastic Buffer Empty Mode External Control (Port 0 Only)		540h
		Device Misc (Port 0 Only)		544h
		Reserved		548h~ 554h
		Switch Domain Mode Control (Port 0 Only)		558h
		Port Clock Control (Port 0 Only)		55Ch
		Reserved		560h ~ 568h
		Performance Counter Control		56Ch
		PHY Source Select		570h
		Reserved		574h ~ 59Ch
		NIC CTRL 0 (Port 0 Only)		5A0h
		NIC CTRL 1 (Port 0 Only)		5A4h
		NIC CTRL 2 (Port 0 Only)		5A8h
		NIC CTRL 3 (Port 0 Only)		5ACh
		NIC CTRL 4 (Port 0 Only)		5B0h
		Reserved		5B4h ~ 5BCh
		CR RW Ctrl and Status (Port 0 Only)		5C0h
		CR CTRL 0 (Port 0 Only)		5C4h
		CR CTRL 1 (Port 0 Only)		5C8h

31 - 24	23 - 16	15 - 8	7 - 0	BYTE OFFSET
CR CTRL 2 (Port 0 Only)				5CCh
CR CTRL 3 (Port 0 Only)				5D0h
Thermal Sensor Test (Port 0 Only)				5D4h
Thermal Sensor Ctrl 0 (Port 0 Only)				5D8h
Thermal Sensor Ctrl 1 (Port 0 Only)				5DCh
Thermal Sensor Ctrl 2 (Port 0 Only)				5E0h
Reserved				5E4h ~ 5FCh
INGRESS Completion TLP Packet Count[31:0]				600h
Reserved	INGRESS Completion TLP Packet Count[47:32]			604h
INGRESS Completion TLP Payload Byte Count[31:0]				608h
Reserved	INGRESS Completion TLP Payload Byte Count[47:32]			60Ch
INGRESS Post TLP Packet Count[31:0]				610h
Reserved	INGRESS Post TLP Packet Count[47:32]			614h
INGRESS Post TLP Payload Byte Count[31:0]				618h
Reserved	INGRESS Post TLP Payload Byte Count[47:32]			61Ch
INGRESS Bad TLP Packet Count[31:0]				620h
Reserved				624h
INGRESS Non-Post TLP Packet Count[31:0]				628h
Reserved	INGRESS Non-Post TLP Packet Count[47:32]			62Ch
EGRESS Completion TLP Packet Count[31:0]				630h
Reserved	EGRESS Completion TLP Packet Count[47:32]			634h
EGRESS Completion TLP Payload Byte Count[31:0]				638h
Reserved	EGRESS Completion TLP Payload Byte Count[47:32]			63Ch
EGRESS Post TLP Packet Count[31:0]				640h
Reserved	EGRESS Post TLP Packet Count[47:32]			644h
EGRESS Post TLP Payload Byte Count[31:0]				648h
Reserved	EGRESS Post TLP Payload Byte Count[47:32]			64Ch
Reserved	EGRESS Error TLP Packet Count[15:0]			650h
Reserved				654h
EGRESS Non-Post TLP Packet Count[31:0]				658h
Reserved	EGRESS Non-Post TLP Packet Count[47:32]			65Ch
TL/DLL/MAC/PHY Error Type Sel				660h
TL/DLL/MAC/PHY Error Count 0				664h
TL/DLL/MAC/PHY Error Count 1				668h
TL/DLL/MAC/PHY Error Count 2				66Ch
TL/DLL/MAC/PHY Error Mask 0				670h
TL/DLL/MAC/PHY Error Mask 1				674h
TL/DLL/MAC/PHY Error Mask 2				678h
Ingress Error Counter Enable				67Ch
Reserved				680h ~ 6FCh
Trigger 1 Mask (Port 0 Only)				700h
Trigger 2 Mask (Port 0 Only)				704h
Pattern 1 Setting (Port 0 Only)				708h
Pattern 2 Setting (Port 0 Only)				70Ch
Trigger 1 Mode Setting (Port 0 Only)				710h
Trigger 2 Mode Setting (Port 0 Only)				714h
Trigger 1 and/or Condition Selection (Port 0 Only)				718h
Trigger 2 and/or Condition Selection (Port 0 Only)				71Ch
Trigger Select (Port 0 Only)				720h
Trigger Position Select (Port 0 Only)				724h
Reserved				728h
Trigger Counter Setting (Port 0 Only)				72Ch
Trigger Start (Port 0 Only)				730h
Read Waveform Data (Port 0 Only)				734h
Sample Rate Setting (Port 0 Only)				738h
Waveform Output Port Select (Port 0 Only)				73Ch
Reserved				740h
Reserved				744h
Waveform Read Event Reset (Port 0 Only)				748h
Dump Memory to GPIO Rate Control (Port 0 Only)				74Ch
Dump Waveform Start (Port 0 Only)				750h
Free Run Button (Port 0 Only)				754h
Reserved				758h ~ FFCh

9.3.1 VENDOR ID REGISTER – OFFSET 00h

BIT	FUNCTION	TYPE	DESCRIPTION	EEPROM/ I2C-SMBUS	DEFAULT
15:0	Vendor ID	RO	Identifies Pericom as the vendor of this device.	Yes	12D8h

9.3.2 DEVICE ID REGISTER – OFFSET 00h

BIT	FUNCTION	TYPE	DESCRIPTION	EEPROM/ I2C-SMBUS	DEFAULT
31:16	Device ID	RO	Identifies this device as the PI7C9X3G816.	Yes	C016h

9.3.3 COMMAND REGISTER – OFFSET 04h

BIT	FUNCTION	TYPE	DESCRIPTION	EEPROM/ I2C-SMBUS	DEFAULT
0	I/O Space Enable	RW	0b: Ignores I/O transactions on the primary interface 1b: Enables responses to I/O transactions on the primary interface	Yes	0
1	Memory Space Enable	RW	0b: Ignores memory transactions on the primary interface 1b: Enables responses to memory transactions on the primary interface	Yes	0
2	Bus Master Enable	RW	0b: Does not initiate memory or I/O transactions on the upstream port and handles asan Unsupported Request (UR) to memory and I/O transactions on the downstream port. For Non-Posted Requests, a completion with UR completion status must be returned 1b: Enables the Switch Port to forward memory and I/O Read/Write transactions in the upstream direction	Yes	0
3	Special Cycle Enable	RsvdP	Not support.	No	0
4	Memory Write And Invalidate Enable	RsvdP	Not support.	No	0
5	VGA Palette Snoop Enable	RsvdP	Not support.	No	0
6	Parity Error Response Enable	RW	0b: Switch may ignore any parity errors that it detects and continue normal operation 1b: Switch must take its normal action when a parity error is detected	Yes	0
7	Wait Cycle Control	RsvdP	Not support.	No	0
8	SERR# enable	RW	0b: Disables the reporting of Non-fatal and Fatal errors detected by the Switch to the Root Complex 1b: Enables the Non-fatal and Fatal error reporting to Root Complex	Yes	0
9	Fast Back-to-Back Enable	RsvdP	Not support.	No	0
10	Interrupt Disable	RW	Controls the ability of a PCI Express device to generate INTx Interrupt Messages. In the Switch, this bit does not affect the forwarding of INTx messages from the downstream ports.	Yes	0
15:11	Reserved	RsvdP	Not support.	No	0000_0b

9.3.4 PRIMARY STATUS REGISTER – OFFSET 04h

BIT	FUNCTION	TYPE	DESCRIPTION	EEPROM/ I2C-SMBUS	DEFAULT
18:16	Reserved	RsvdP	Not support.	No	000b
19	Interrupt Status	RO	Indicates that an INTx Interrupt Message is pending internally to the device. In the Switch, the forwarding of INTx messages from the downstream device of the Switch port is not reflected in this bit. Must be hardwired to 0.	No	0
20	Capabilities List	RO	Set to 1b to enable support for the capability list (offset 34h is the pointer to the data structure).	Yes/No	1
21	66MHz Capable	RO	Does not apply to PCI Express. Must be hardwired to 0.	No	0
22	Reserved	RsvdP	Not support.	No	0

BIT	FUNCTION	TYPE	DESCRIPTION	EEPROM/ I2C-SMBUS	DEFAULT
23	Fast Back-to-Back Capable	RsvdP	Not support.	No	0
24	Master Data Parity Error	RW1C	Set to 1b (by a requester) whenever a Parity error is detected or forwarded on the primary side of the port in a Switch. If the Parity Error Response Enable bit is cleared, this bit is never set.	No/Yes	0
26:25	DEVSEL# timing	RsvdP	Not support.	No	00b
27	Signaled Target Abort	RW1C	Set when the Secondary Side for Type 1 Configuration Space header Function (for Requests completed by the Type 1 header Function itself) completes a Posted or Non-Posted Request as a Completer Abort error.	No/Yes	0
28	Received Target Abort	RsvdP	Not support.	No	0
29	Received Master Abort	RsvdP	Not support.	No	0
30	Signaled System Error	RW1C	Set to 1b when the Switch sends an ERR_FATAL or ERR_NONFATAL Message, and the SERR Enable bit in the Command register is 1b.	No/Yes	0
31	Detected Parity Error	RW1C	Set to 1b whenever the primary side of the port in a Switch receives a Poisoned TLP.	No/Yes	0

9.3.5 REVISION ID REGISTER – OFFSET 08h

BIT	FUNCTION	TYPE	DESCRIPTION	EEPROM/ I2C-SMBUS	DEFAULT
7:0	Revision	RO	Indicates revision number of device.	Yes	07h for Port 0 06h for Port 1-7

9.3.6 CLASS REGISTER – OFFSET 08h

BIT	FUNCTION	TYPE	DESCRIPTION	EEPROM/ I2C-SMBUS	DEFAULT
15:8	Programming Interface	RO	Read as 00h to indicate no programming interfaces have been defined for PCI-to-PCI Bridges.	No	00h
23:16	Sub-Class Code	RO	Read as 04h to indicate device is a PCI-to-PCI Bridge.	No	04h
31:24	Base Class Code	RO	Read as 06h to indicate device is a Bridge device.	No	06h

9.3.7 CACHE LINE REGISTER – OFFSET 0Ch

BIT	FUNCTION	TYPE	DESCRIPTION	EEPROM/ I2C-SMBUS	DEFAULT
7:0	Cache Line Size	RW	The cache line size register is set by the system firmware and the operating system cache line size. This field is implemented by PCI Express devices as a RW field for legacy compatibility, but it has no impact on any PCI Express device functionality.	Yes	00h

9.3.8 PRIMARY LATENCY TIMER REGISTER – OFFSET 0Ch

BIT	FUNCTION	TYPE	DESCRIPTION	EEPROM/ I2C-SMBUS	DEFAULT
15:8	Primary Latency Timer	RsvdP	Not support.	No	00h

9.3.9 HEADER TYPE REGISTER – OFFSET 0Ch

BIT	FUNCTION	TYPE	DESCRIPTION	EEPROM/ I2C-SMBUS	DEFAULT
22:16	Header Type	RO	Read as 01h to indicate that the register layout conforms to the standard PCI-to-PCI Bridge layout.	No	01h

BIT	FUNCTION	TYPE	DESCRIPTION	EEPROM/ I2C-SMBUS	DEFAULT
23	Multi-Function Device	RO	0b: Single function device 1b: Multiple functions device	No	0 if DMA=0 1 if DMA=1

9.3.10 BASE ADDRESS 0 REGISTER – OFFSET 10h (Upstream Port Only)

BIT	FUNCTION	TYPE	DESCRIPTION	EEPROM/ I2C-SMBUS	DEFAULT
0	Memory Space Indicator	RO	Reset to 0 to indicate Memory Base address.	No	0
2:1	64-bit Addressing	RO	00b: 32-bit addressing 10b: 64-bit addressing Others: Reserved	No	00b
3	Prefetchable	RO	0b: Non-prefetchable 1b: Prefetchable	No	0
18:4	Reserved	RsvdP	Not support.	No	0-0h
31:19	Base Address 0 [31:19]	RW	Use this Memory base address to map the packet switch registers.	Yes	0-0h

9.3.11 BASE ADDRESS 1 REGISTER – OFFSET 14h (Upstream Port Only)

BIT	FUNCTION	TYPE	DESCRIPTION	EEPROM/ I2C-SMBUS	DEFAULT
31:0	Reserved	RO	When the Base Address 0 register is not 64-bit addressing (offset 10h[2:1] is not 10b).	No	0000_0000h
	Base Address 0 [63:32]	RW	When the Base Address 0 register is 64-bit addressing. Base Address 1 is used to provide the upper 32 Address bits when offset 10h[2:1] is set to 10b.	Yes	

9.3.12 PRIMARY BUS NUMBER REGISTER – OFFSET 18h

BIT	FUNCTION	TYPE	DESCRIPTION	EEPROM/ I2C-SMBUS	DEFAULT
7:0	Primary Bus Number	RW	Indicates the number of the PCI bus to which the primary interface is connected. The value is set in software during configuration.	Yes	00h

9.3.13 SECONDARY BUS NUMBER REGISTER – OFFSET 18h

BIT	FUNCTION	TYPE	DESCRIPTION	EEPROM/ I2C-SMBUS	DEFAULT
15:8	Secondary Bus Number	RW	Indicates the number of the PCI bus to which the secondary interface is connected. The value is set in software during configuration.	Yes	00h

9.3.14 SUBORDINATE BUS NUMBER REGISTER – OFFSET 18h

BIT	FUNCTION	TYPE	DESCRIPTION	EEPROM/ I2C-SMBUS	DEFAULT
23:16	Subordinate Bus Number	RW	Indicates the number of the PCI bus with the highest number that is subordinate to the Bridge. The value is set in software during configuration.	Yes	00h

9.3.15 SECONDARY LATENCY TIMER REGISTER – OFFSET 18h

BIT	FUNCTION	TYPE	DESCRIPTION	EEPROM/ I2C-SMBUS	DEFAULT
31:24	Secondary Latency Timer	RsvdP	Not support.	No	00h

9.3.16 I/O BASE ADDRESS REGISTER – OFFSET 1Ch

BIT	FUNCTION	TYPE	DESCRIPTION	EEPROM/ I2C-SMBUS	DEFAULT
3:0	32-bit Indicator	RO	Read as 1h to indicate 32-bit I/O addressing.	Yes	1h
7:4	I/O Base Address [15:12]	RW	Defines the bottom address of the I/O address range for the Bridge to determine when to forward I/O transactions from one interface to the other. The upper 4 bits correspond to address bit[15:12] and are writable. The lower 12 bits corresponding to address bit[11:0] are assumed to be 0. The upper 16 bits corresponding to address bit[31:16] are defined in the I/O base address upper 16 bits address register.	Yes	Fh

9.3.17 I/O LIMIT ADDRESS REGISTER – OFFSET 1Ch

BIT	FUNCTION	TYPE	DESCRIPTION	EEPROM/ I2C-SMBUS	DEFAULT
11:8	32-bit Indicator	RO	Read as 1h to indicate 32-bit I/O addressing.	Yes	1h
15:12	I/O Limit Address [15:12]	RW	Defines the top address of the I/O address range for the Bridge to determine when to forward I/O transactions from one interface to the other. The upper 4 bits correspond to address bit[15:12] and are writable. The lower 12 bits corresponding to address bit[11:0] are assumed to be FFFh. The upper 16 bits corresponding to address bit[31:16] are defined in the I/O limit address upper 16 bits address register.	Yes	0h

9.3.18 SECONDARY STATUS REGISTER – OFFSET 1Ch

BIT	FUNCTION	TYPE	DESCRIPTION	EEPROM/ I2C-SMBUS	DEFAULT
20:16	Reserved	RsvdP	Not support.	No	0_0000b
21	66MHz Capable	RsvdP	Not support.	No	0
22	Reserved	RsvdP	Not support.	No	0
23	Fast Back-to-Back Capable	RsvdP	Not support.	No	0
24	Master Data Parity Error	RW1C	Set to 1b (by a requester) whenever a Parity error is detected or forwarded on the secondary side of the port in a Switch. If the Parity Error Response Enable bit is cleared, this bit is never set.	No/Yes	0
26:25	DEVSEL_L timing	RsvdP	Not support.	No	00b
27	Signaled Target Abort	RW1C	Set when the Secondary Side for Type 1 Configuration Space header Function (for Requests completed by the Type 1 header Function itself) completes a Posted or Non-Posted Request as a Completer Abort error.	No/Yes	0
28	Received Target Abort	RsvdP	Not support.	No	0
29	Received Master Abort	RsvdP	Not support.	No	0
30	Received System Error	RW1C	Set to 1b when the Switch sends an ERR_FATAL or ERR_NONFATAL Message, and the SERR Enable bit in the Bridge Control register is 1.	No/Yes	0
31	Detected Parity Error	RW1C	Set to 1b whenever the secondary side of the port in a Switch receives a Poisoned TLP.	No/Yes	0

9.3.19 MEMORY BASE ADDRESS REGISTER – OFFSET 20h

BIT	FUNCTION	TYPE	DESCRIPTION	EEPROM/ I2C-SMBUS	DEFAULT
3:0	Reserved	RsvdP	Not support.	No	0h

BIT	FUNCTION	TYPE	DESCRIPTION	EEPROM/ I2C-SMBUS	DEFAULT
15:4	Memory Base Address [15:4]	RW	Defines the bottom address of an address range for the Bridge to determine when to forward memory transactions from one interface to the other. The upper 12 bits correspond to address bit[31:20] and are able to be written to. The lower 20 bits corresponding to address bit[19:0] are assumed to be 0.	Yes	000h

9.3.20 MEMORY LIMIT ADDRESS REGISTER – OFFSET 20h

BIT	FUNCTION	TYPE	DESCRIPTION	EEPROM/ I2C-SMBUS	DEFAULT
19:16	Reserved	RsvdP	Not support.	No	0h
31:20	Memory Limit Address [31:20]	RW	Defines the top address of an address range for the Bridge to determine when to forward memory transactions from one interface to the other. The upper 12 bits correspond to address bit[31:20] and are writable. The lower 20 bits corresponding to address bit[19:0] are assumed to be FFFFh.	Yes	000h

9.3.21 PREFETCHABLE MEMORY BASE ADDRESS REGISTER – OFFSET 24h

BIT	FUNCTION	TYPE	DESCRIPTION	EEPROM/ I2C-SMBUS	DEFAULT
3:0	64-bit addressing	RO	Read as 1h to indicate 64-bit addressing.	No	1h
15:4	Prefetchable Memory Base Address [31:20]	RW	Defines the bottom address of an address range for the Bridge to determine when to forward memory read and write transactions from one interface to the other. The upper 12 bits correspond to address bit[31:20] and are writable. The lower 20 bits are assumed to be 0. The memory base register upper 32 bits contain the upper half of the base address.	Yes	000h

9.3.22 PREFETCHABLE MEMORY LIMIT ADDRESS REGISTER – OFFSET 24h

BIT	FUNCTION	TYPE	DESCRIPTION	EEPROM/ I2C-SMBUS	DEFAULT
19:16	64-bit addressing	RO	Read as 1h to indicate 64-bit addressing.	No	1h
31:20	Memory Limit Address [31:20]	RW	Defines the top address of an address range for the Bridge to determine when to forward memory transactions from one interface to the other. The upper 12 bits correspond to address bit[31:20] and are writable. The lower 20 bits corresponding to address bit[19:0] are assumed to be FFFFh.	Yes	000h

9.3.23 PREFETCHABLE MEMORY BASE ADDRESS UPPER 32-BITS REGISTER – OFFSET 28h

BIT	FUNCTION	TYPE	DESCRIPTION	EEPROM/ I2C-SMBUS	DEFAULT
31:0	Prefetchable Memory Base Address, Upper 32-bit[63:32]	RW	Defines the upper 32-bits of a 64-bit bottom address of an address range for the Bridge to determine when to forward memory read and write transactions from one interface to the other.	Yes	0000_0000h

9.3.24 PREFETCHABLE MEMORY LIMIT ADDRESS UPPER 32-BITS REGISTER – OFFSET 2Ch

BIT	FUNCTION	TYPE	DESCRIPTION	EEPROM/ I2C-SMBUS	DEFAULT
31:0	Prefetchable Memory Limit Address, Upper 32-bit[63:32]	RW	Defines the upper 32-bits of a 64-bit top address of an address range for the Bridge to determine when to forward memory read and write transactions from one interface to the other.	Yes	0000_0000h

9.3.25 I/O BASE ADDRESS UPPER 16-BITS REGISTER – OFFSET 30h

BIT	FUNCTION	TYPE	DESCRIPTION	EEPROM/ I2C-SMBUS	DEFAULT
15:0	I/O Base Address, Upper 16-bit[31:16]	RW	Defines the upper 16-bits of a 32-bit bottom address of an address range for the Bridge to determine when to forward I/O transactions from one interface to the other.	Yes	0000_0000h

9.3.26 I/O LIMIT ADDRESS UPPER 16-BITS REGISTER – OFFSET 30h

BIT	FUNCTION	TYPE	DESCRIPTION	EEPROM/ I2C-SMBUS	DEFAULT
31:16	I/O Limit Address, Upper 16-bit[31:16]	RW	Defines the upper 16-bits of a 32-bit top address of an address range for the Bridge to determine when to forward I/O transactions from one interface to the other.	Yes	0000_0000h

9.3.27 CAPABILITY POINTER REGISTER – OFFSET 34h

BIT	FUNCTION	TYPE	DESCRIPTION	EEPROM/ I2C-SMBUS	DEFAULT
7:0	Capability Pointer	RO	Pointer points to first PCI capability structure.	Yes	40h

9.3.28 INTERRUPT LINE REGISTER – OFFSET 3Ch

BIT	FUNCTION	TYPE	DESCRIPTION	EEPROM/ I2C-SMBUS	DEFAULT
7:0	Interrupt Line	RW	The interrupt line register communicates interrupt line routing information.	Yes	00h

9.3.29 INTERRUPT PIN REGISTER – OFFSET 3Ch

BIT	FUNCTION	TYPE	DESCRIPTION	EEPROM/ I2C-SMBUS	DEFAULT
15:8	Interrupt Pin	RO	The Switch implements INTA virtual wire interrupt signals to represent hot-plug events at downstream ports. 0b: disable INTA 1b: enable INTA	Yes	00h for Up 01h for Down

9.3.30 BRIDGE CONTROL REGISTER – OFFSET 3Ch

BIT	FUNCTION	TYPE	DESCRIPTION	EEPROM/ I2C-SMBUS	DEFAULT
16	Parity Error Response	RW	0b: Ignore Poisoned TLPs on the secondary interface 1b: Enable the Poisoned TLPs reporting and detection on the secondary interface	Yes	0
17	S_SERR# Enable	RW	0b: Disables the forwarding of EER_COR, ERR_NONFATAL and ERR_FATAL from secondary to primary interface 1b: Enables the forwarding of EER_COR, ERR_NONFATAL and ERR_FATAL from secondary to primary interface	Yes	0
18	ISA Enable	RW	0b: Forwards downstream all I/O addresses in the address range defined by the I/O Base, I/O Base, and Limit registers 1b: Forwards upstream all I/O addresses in the address range defined by the I/O Base and Limit registers that are in the first 64KB of PCI I/O address space (top 768 bytes of each 1KB block)	Yes	0
19	VGA Enable	RW	0b: Ignores access to the VGA memory or IO address range 1b: Forwards transactions targeted at the VGA memory or IO address range VGA memory range starts from 000A 0000h to 000B FFFFh VGA IO addresses are in the first 64KB of IO address space.	Yes	0

BIT	FUNCTION	TYPE	DESCRIPTION	EEPROM/ I2C-SMBUS	DEFAULT
			AD [9:0] is in the ranges 3B0 to 3BBh and 3C0h to 3DFh.		
20	VGA 16-bit Decode	RW	0b: Executes 10-bit address decoding on VGA I/O accesses 1b: Executes 16-bit address decoding on VGA I/O accesses	Yes	0
21	Master Abort Mode	RsvdP	Not support.	No	0
22	Secondary Bus Reset	RW	0b: Does not trigger a hot reset on the corresponding PCI Express Port 1b: Triggers a hot reset on the corresponding PCI Express Port At the downstream port, it asserts PORT_RST# to the attached downstream device. At the upstream port, it asserts the PORT_RST# at all the downstream ports.	Yes	0
23	Fast Back-to-Back Enable	RsvdP	Not support.	No	0
24	Primary Master Timeout	RsvdP	Not support.	No	0
25	Secondary Master Timeout	RsvdP	Not support.	No	0
26	Master Timeout Status	RsvdP	Not support.	No	0
27	Discard Timer SERR# Enable	RsvdP	Not support.	No	0
31:28	Reserved	RsvdP	Not support.	No	0h

9.3.31 POWER MANAGEMENT CAPABILITIES REGISTER – OFFSET 40h

BIT	FUNCTION	TYPE	DESCRIPTION	EEPROM/ I2C-SMBUS	DEFAULT
7:0	Enhanced Capabilities ID	RO	Read as 01h to indicate that this is power management capability register.	Yes	01h
15:8	Next Item Pointer	RO	Point to next capability structure.	Yes	48h
18:16	Power Management Revision	RO	Read as 011b to indicate the device is compliant to Revision 1.2 of <i>PCI Power Management Interface Specifications</i> .	No	011b
19	PME# Clock	RO	Does not apply to PCI Express. Must be hardwired to 0.	No	0
20	Reserved	RsvdP	Not support.	No	0
21	Device specific Initialization	RO	Read as 0b to indicate Switch does not have device specific initialization requirements.	Yes	0
24:22	AUX Current	RO	Reset to 0.	Yes	000b
25	D1 Power State Support	RO	Read as 0b to indicate Switch does Not support the D1 power management state.	Yes	0
26	D2 Power State Support	RO	Read as 0b to indicate Switch does Not support the D2 power management state.	Yes	0
31:27	PME# Support	RO	Read as 19h to indicate Switch supports the forwarding of PME# message in D0, D3 and D4 states.	Yes	19h

9.3.32 POWER MANAGEMENT DATA REGISTER – OFFSET 44h

BIT	FUNCTION	TYPE	DESCRIPTION	EEPROM/ I2C-SMBUS	DEFAULT
1:0	Power State	RW	Indicates the current power state of the Switch. Writing a value of D0 when the previous state was D3 cause a hot reset without asserting DWRST_L. 00b: D0 state 01b: D1 state 10b: D2 state 11b: D3 hot state	Yes	00b
2	Reserved	RsvdP	Not support.	No	0
3	No_Soft_Reset	RO	When set, this bit indicates that device transitioning from D3hot to D0 does not perform an internal reset. When clear, an internal reset is performed when power state transits from D3hot to D0.	Yes	1
7:4	Reserved	RsvdP	Not support.	No	0h

BIT	FUNCTION	TYPE	DESCRIPTION	EEPROM/ I2C-SMBUS	DEFAULT
8	PME# Enable	RW	When asserted, the Switch will generate the PME# message.	Yes	0
12:9	Data Select	RW	Select data registers. RW if offset 4C4h[9] =1 and RO if offset 4C4h[9] =0.	Yes	0h
14:13	Data Scale	RO	Reset to 00b.	No	00b
15	PME Status	RW1C	Read as 0b as the PME# message is not implemented.	Yes	0

9.3.33 PPB SUPPORT EXTENSIONS REGISTER – OFFSET 44h

BIT	FUNCTION	TYPE	DESCRIPTION	EEPROM/ I2C-SMBUS	DEFAULT
21:16	Reserved	RsvdP	Not support.	No	00h
22	B2_B3 Support for D3 _{HOT}	RsvdP	Not support.	No	0
23	Bus Power / Clock Control Enable	RsvdP	Not support.	No	0

9.3.34 DATA REGISTER– OFFSET 44h

BIT	FUNCTION	TYPE	DESCRIPTION	EEPROM/ I2C-SMBUS	DEFAULT
31:24	Data Register	RO	Data Register.	Yes	00h

9.3.35 MSI CAPABILITIES REGISTER – OFFSET 48h

BIT	FUNCTION	TYPE	DESCRIPTION	EEPROM/ I2C-SMBUS	DEFAULT
7:0	Enhanced Capabilities ID	RO	Read as 05h to indicate that this is message signal interrupt capability register.	No	05h
15:8	Next Item Pointer	RO	Pointer points to next PCI capability structure.	Yes	68h
16	MSI Enable	RW	0b: The function is prohibited from using MSI to request service 1b: The function is permitted to use MSI to request service and is prohibited from using its INTx # pin	Yes	0
19:17	Multiple Message Capable	RO	Indicate the number of requested vectors.	Yes	011b
22:20	Multiple Message Enable	RW	Software writes to this field to indicate the number of allocated vectors (equal to or less than the number of requested vectors.)	Yes	000b
23	64-bit address capable	RO	0b: The function is not capable of generating a 64-bit message address 1b: The function is capable of generating a 64-bit message address	Yes	1b
24	Pre-vector Masking Capable	RO	1b: the function supports MSI pre-vector masking. 0b: the function does Not support MSI pre-vector masking.	Yes	1b
31:25	Reserved	RO	Not support.	No	00h

9.3.36 MESSAGE ADDRESS REGISTER – OFFSET 4Ch

BIT	FUNCTION	TYPE	DESCRIPTION	EEPROM/ I2C-SMBUS	DEFAULT
1:0	Reserved	RsvdP	Not support.	No	00b
31:2	Message Address	RW	If the message enable bit is set, the contents of this register specify the DWORD aligned address for MSI memory write transaction.	Yes	0-0h

9.3.37 MESSAGE UPPER ADDRESS REGISTER – OFFSET 50h

BIT	FUNCTION	TYPE	DESCRIPTION	EEPROM/ I2C-SMBUS	DEFAULT
31:0	Message Upper Address	RW	This register is only effective if the device supports a 64-bit message address is set.	Yes	0000_0000h

9.3.38 MESSAGE DATA REGISTER – OFFSET 54h

BIT	FUNCTION	TYPE	DESCRIPTION	EEPROM/ I2C-SMBUS	DEFAULT
15:0	Message Data	RW	Message data.	Yes	0000h

9.3.39 MESSAGE MASK REGISTER – OFFSET 58h

BIT	FUNCTION	TYPE	DESCRIPTION	EEPROM/ I2C-SMBUS	DEFAULT
0	MSI Mask for Hot Plug	RW	MSI mask for Hot Plug interrupts.	Yes	0
1	MSI Mask for DPC	RW	MSI mask for DPC interrupts.	Yes	0
2	MSI Mask for DMA and GPIO	RW	MSI mask for DMAGPIO interrupts.	Yes	0
3	MSI Mask for CDEP	RW	MSI mask for CDEP interrupts.	Yes	0
4	Reserved	RsvdP	Not support.	No	0
5	MSI Mask for thermal sensor	RW	MSI mask for thermal sensor interrupts.	Yes	0
7:6	Reserved	RW	Not support.	No	00
31:8	Reserved	RsvdP	Not support.	No	0000_000h

9.3.40 MESSAGE PENDING REGISTER – OFFSET 5Ch

BIT	FUNCTION	TYPE	DESCRIPTION	EEPROM/ I2C-SMBUS	DEFAULT
0	MSI Pending for Hot Plug Interrupts	RO	MSI pending status for Hot Plug interrupts.	No	0
1	MSI Pending for DPC Interrupts	RO	MSI pending status for DPC interrupts.	No	0
2	MSI Pending for GPIO Interrupts	RO	MSI pending status for GPIO interrupts.	No	0
3	MSI Pending for CDEP Interrupts	RO	MSI pending status for CDEP interrupts.	No	0
4	Reserved	RsvdP	Not support.	No	0
5	MSI Pending for thermal sensor Interrupts	RO	MSI pending status for thermal sensor interrupts.	No	0
31:6	Reserved	RsvdP	Not support.	No	0000_000h

9.3.41 PCI EXPRESS CAPABILITIES REGISTER – OFFSET 68h

BIT	FUNCTION	TYPE	DESCRIPTION	EEPROM/ I2C-SMBUS	DEFAULT
7:0	Enhanced Capabilities ID	RO	Read as 10h to indicate that this is PCI express capability register.	No	10h
15:8	Next Item Pointer	RO	Point to next PCI capability structure.	Yes	A4h
19:16	Capability Version	RO	Read as 2h to indicate the device is compliant to Revision .2.0 of <i>PCI Express Base Specifications</i> .	Yes	2h
23:20	Device/Port Type	RO	Indicates the type of PCI Express logical device.	Yes	5h for Up 6h for Down
24	Slot Implemented	RO	Valid for downstream ports only. When set, indicates that the PCIe Link associated with this Port is connected to a slot. This field is valid for downstream ports of the Switch.	Yes	0 for Up 1 for Down
29:25	Interrupt Message Number	RO	Read as 0. No MSI messages are generated in the transparent mode.	No	00_000b
31:30	Reserved	RsvdP	Not support.	No	00b

9.3.42 DEVICE CAPABILITIES REGISTER – OFFSET 6Ch

BIT	FUNCTION	TYPE	DESCRIPTION	EEPROM/ I2C-SMBUS	DEFAULT
2:0	Max_Payload_Size Supported	RO	Indicates the maximum payload size that the device can support for TLPs. Each port of the Switch supports 512 bytes max payload size.	Yes	010b
4:3	Phantom Functions Supported	RO	Indicates the support for use of unclaimed function numbers as Phantom functions. Read as 00b, since the Switch does not act as a requester.	No	00b
5	Extended Tag Field Supported	RO	Indicates the maximum supported size of Tag field as a Requester. Read as 0, since the Switch does not act as a requester.	No	0
8:6	Endpoint L0s Acceptable Latency	RO	Acceptable total latency that an Endpoint can withstand due to the transition from L0s state to the L0 state. For Switch, the ASPM software would not check this value.	No	000b
11:9	Endpoint L1 Acceptable Latency	RO	Acceptable total latency that an Endpoint can withstand due to the transition from L1 state to the L0 state. For Switch, the ASPM software would not check this value.	No	000b
14:12	Reserved	RsvdP	Not support.	No	000b
15	Role_Based Error Reporting	RO	When set, indicates that the device implements the functionality originally defined in the Error Reporting ECN.	Yes	1
17:16	Reserved	RsvdP	Not support.	No	00b
25:18	Captured Slot Power Limit Value	RO	It applies to Upstream Port only. In combination with the Slot Power Limit Scale value, specifies the upper limit on power supplied by slot. This value is set by the Set_Slot_Power_Limit message or hardwired to 00h.	No	00h
27:26	Captured Slot Power Limit Scale	RO	It applies to Upstream Port only. Specifies the scale used for the Slot Power Limit Value. This value is set by the Set_Slot_Power_Limit message or hardwired to 00b.	No	00b
31:28	Reserved	RsvdP	Not support.	No	0h

9.3.43 DEVICE CONTROL REGISTER – OFFSET 70h

BIT	FUNCTION	TYPE	DESCRIPTION	EEPROM/ I2C-SMBUS	DEFAULT
0	Correctable Error Reporting Enable	RW	0b: Disable Correctable Error Reporting 1b: Enable Correctable Error Reporting	Yes	0
1	Non-Fatal Error Reporting Enable	RW	0b: Disable Non-Fatal Error Reporting 1b: Enable Non-Fatal Error Reporting	Yes	0
2	Fatal Error Reporting Enable	RW	0b: Disable Fatal Error Reporting 1b: Enable Fatal Error Reporting	Yes	0
3	Unsupported Request Reporting Enable	RW	0b: Disable Unsupported Request Reporting 1b: Enable Unsupported Request Reporting	Yes	0
4	Enable Relaxed Ordering	RsvdP	When set, it permits the device to set the Relaxed Ordering bit in the attribute field of transaction. Since the Switch can not either act as a requester or alter the content of packet it forwards, this bit always returns '0' when read.	No	0
7:5	Max_Payload_Size	RW	This field sets maximum TLP payload size for the device. Permissible values that can be programmed are indicated by the Max_Payload_Size Supported in the Device Capabilities register. Any value exceeding the Max_Payload_Size Supported written to this register results into clamping to the Max_Payload_Size Supported value.	Yes	000b
8	Extended Tag Field Enable	RsvdP	Does not apply to PCI Express Switch. Returns '0' when read.	No	0
9	Phantom Function Enable	RsvdP	Does not apply to PCI Express Switch. Returns '0' when read.	No	0
10	Auxiliary (AUX) Power PM Enable	RO	When set, indicates that a device is enabled to draw AUX power independent of PME AUX power.	No	0

BIT	FUNCTION	TYPE	DESCRIPTION	EEPROM/ I2C-SMBUS	DEFAULT
11	Enable No Snoop	RsvdP	When set, it permits to set the No Snoop bit in the attribute field of transaction. Since the Switch can not either act as a requester or alter the content of packet it forwards, this bit always returns '0' when read.	No	0
14:12	Max_Read_Request_Size	RsvdP	This field sets the maximum Read Request size for the device as a Requester. Since the Switch does not generate read request by itself, these bits are hardwired to 000b.	No	000b
15	Reserved	RsvdP	Not support.	No	0

9.3.44 DEVICE STATUS REGISTER – OFFSET 70h

BIT	FUNCTION	TYPE	DESCRIPTION	EEPROM/ I2C-SMBUS	DEFAULT
16	Correctable Error Detected	RW1C	Asserted when correctable error is detected. Errors are logged in this register regardless of whether error reporting is enabled or not in the Device Control register.	Yes	0
17	Non-Fatal Error Detected	RW1C	Asserted when non-fatal error is detected. Errors are logged in this register regardless of whether error reporting is enabled or not in the Device Control register.	Yes	0
18	Fatal Error Detected	RW1C	Asserted when fatal error is detected. Errors are logged in this register regardless of whether error reporting is enabled or not in the Device Control register.	Yes	0
19	Unsupported Request Detected	RW1C	Asserted when unsupported request is detected. Errors are logged in this register regardless of whether error reporting is enabled or not in the Device Control register.	Yes	0
20	AUX Power Detected	RO	Asserted when the AUX power is detected by the Switch	No	0
21	Transactions Pending	RO	Each port of Switch does not issue Non-posted Requests on its own behalf, so this bit is hardwired to 0b.	No	0
31:22	Reserved	RsvdP	Not support.	No	0-0h

9.3.45 LINK CAPABILITIES REGISTER – OFFSET 74h

BIT	FUNCTION	TYPE	DESCRIPTION	EEPROM/ I2C-SMBUS	DEFAULT
3:0	Maximum Link Speed	RO	Indicate the maximum speed of the Express link is 8Gb/s, 5Gb/s and 2.5 Gb/s. 0001b: 2.5 Gb/s 0010b: 5.0 Gb/s 0011b: 8.0 Gb/s Others: Reserved	Yes	3h
9:4	Maximum Link Width	RO	Indicates the maximum width of the given PCIe Link. 00_0001b: x1 lane width 00_0010b: x2 lane width 00_0100b: x4 lane width 00_1000b: x8 lane width	Yes	Set by PORTCFG [2:0]
11:10	Active State Power Management (ASPM) Support	RO	Indicates the level of ASPM supported on the given PCIe Link. Each port of Switch supports L0s and L1 entry.	Yes	10b
14:12	L0s Exit Latency	RO	Indicates the L0s exit latency for the given PCIe Link. The length of time this port requires to complete transition from L0s to L0 is in the range of 256ns to less than 512ns.	Yes	011b
17:15	L1 Exit Latency	RO	Indicates the L1 exit latency for the given PCIe Link. The length of time this port requires to complete transition from L1 to L0 is less than 1us.	Yes	000b
18	Clock Power Management	RO	For upstream port, a value of 1b indicates that component tolerates the removal of any reference clock via CLKREQ#. For downstream ports, this bit must be hardwired to 0b.	Yes	1 for Up 0 for Down

BIT	FUNCTION	TYPE	DESCRIPTION	EEPROM/ I2C-SMBUS	DEFAULT
19	Surprise Down Error Reporting Capable	RO	For downstream port, this bit must be set if the component supports the optional capability of detecting and reporting a surprise down error condition. For upstream port, this bit must be hardwired to 0b.	Yes	0 for Up 1 for Down
20	Data Link Layer Active Reporting Capable	RO	For downstream ports, this bit must be set to 1b if the component supports the optional capability of reporting the DL_Active state of the Data Link Control and Management State Machine. For a hot-plug capable downstream port, this bit must be set to 1b. For upstream port, this bit must be hardwired to 0b.	Yes	0 for Up 1 for Down
21	Link BW Notify Cap.	RO	Valid for downstream ports only.	Yes	0 for Up 1 for Down
22	ASPM Optionality Compliance	RO	Software is permitted to use the value of this bit to help determine whether to enable ASPM or whether to run ASPM compliance tests.	Yes	1
23	Reserved	RsvdP	Not support.	No	0
31:24	Port Number	RO	Indicates the PCIe Port Number for the given PCIe Link.	Yes	00h for Up 01 h for Port 1 02h for Port 2 03h for Port 3

9.3.46 LINK CONTROL REGISTER – OFFSET 78h

BIT	FUNCTION	TYPE	DESCRIPTION	EEPROM/ I2C-SMBUS	DEFAULT
1:0	Active State Power Management (ASPM) Control	RW	00b: ASPM is Disabled 01b: L0s Entry Enabled 10b: L1 Entry Enabled 11b: L0s and L1 Entry Enabled Note that the receiver must be capable of entering L0s even when the field is disabled	Yes	00b
2	Reserved	RsvdP	Not support.	No	0
3	Read Completion Boundary (RCB)	RsvdP	Not support.	No	0
4	Link Disable	RW	At upstream port, it is not allowed to disable the link, so this bit is hardwired to '0'. For downstream ports, it disables the link when this bit is set.	Yes	0
5	Retrain Link	RW	At upstream port, it is not allowed to retrain the link, so this bit is hardwired to 0. For downstream ports, it initiates Link Retraining when this bit is set. This bit always returns '0' when read.	Yes	0
6	Common Clock Configuration	RW	0b: The components at both ends of a link are operating with synchronous reference clock 1b: The components at both ends of a link are operating with a distributed common reference clock	Yes	0
7	Extended Synch	RW	When set, it transmits 4096 FTS ordered sets in the L0s state for entering L0 state and transmits 1024 TS1 ordered sets in the L1 state for entering L0 state.	Yes	0
8	Enable Clock Power Management	RW	Valid for upstream port only: 0b: clock power management is disabled and must hold CLKREQ# low 1b: device is permitted to use CLKREQ# to power manage Link clock	Yes	0
9	HW Autonomous Width Disable	RW	Reset to 0.	Yes	0
10	Link Bandwidth Management Interrupt Enable	RW	Valid for downstream ports only.	Yes	0

BIT	FUNCTION	TYPE	DESCRIPTION	EEPROM/ I2C-SMBUS	DEFAULT
11	Link Autonomous Bandwidth Interrupt Enable	RW	Valid for downstream ports only.	Yes	0
15:12	Reserved	RsvdP	Not support.	No	0h

9.3.47 LINK STATUS REGISTER – OFFSET 78h

BIT	FUNCTION	TYPE	DESCRIPTION	EEPROM/ I2C-SMBUS	DEFAULT
19:16	Link Speed	RO	Indicates the negotiated speed of the Express link. 0001b: 2.5 Gb/s 0010b: 5.0 Gb/s 0011b: 8.0 Gb/s Others: Reserved	No	1h
25:20	Negotiated Link Width	RO	Indicates the negotiated width of the given PCIe link. 00_0001b: x1 lane width 00_0010b: x2 lane width 00_0100b: x4 lane width 00_1000b: x8 lane width	No	Set by PORTCFG [2:0]
26	Training Error	RO	When set, indicates a Link training error occurred. This bit is cleared by hardware upon successful training of the link to the L0 link state.	No	0
27	Link Training	RO	When set, indicates the link training is in progress. Hardware clears this bit once link training is complete.	No	0
28	Slot Clock Configuration	RO	0b: the Switch uses an independent clock irrespective of the presence of a reference on the connector 1b: the Switch uses the same reference clock that the platform provides on the connector	Yes	1 for Up 0 for Down
29	Data Link Layer Link Active	RO	Indicates the status of the Data Link Control and Management State Machine. 1b: indicate the DL_Active state 0b: otherwise	No	0
30	Link Bandwidth Management Status	RW1C	Valid for downstream port only.	Yes	0
31	Link Autonomous Bandwidth Status	RW1C	Valid for downstream port only.	Yes	0

9.3.48 SLOT CAPABILITIES REGISTER – OFFSET 7Ch (Downstream Port Only)

BIT	FUNCTION	TYPE	DESCRIPTION	EEPROM/ I2C-SMBUS	DEFAULT
0	Attention Button Present	RO	When set, it indicates that an Attention Button is implemented on the chassis for this slot.	Yes	1
1	Power Controller Present	RO	When set, it indicates that a Power Controller is implemented for this slot.	Yes	1
2	MRL Sensor Present	RO	When set, it indicates that a MRL Sensor is implemented for this slot.	Yes	1
3	Attention Indicator Present	RO	When set, it indicates that an Attention Indicator is implemented on the chassis for this slot	Yes	1
4	Power Indicator Present	RO	When set, it indicates that a Power Indicator is implemented on the chassis for this slot.	Yes	1
5	Hot-Plug Surprise	RO	When set, it indicates that a device present in this slot might be removed from the system without any prior notification.	No/Yes	Set by SURPRISE_HP
6	Hot-Plug Capable	RO	When set, it indicates that this slot is capable of supporting Hot-Plug operation.	Yes	Set by HOT_PLUG_EN_L
14:7	Slot Power Limit Value	RO	In combination with the Slot Power Limit Scale value, specifies the upper limit on power supplied by slot. Writes to this register also cause the Port to send the Set_Slot_Power_Limit message.	Yes	19h

BIT	FUNCTION	TYPE	DESCRIPTION	EEPROM/ I2C-SMBUS	DEFAULT
16:15	Slot Power Limit Scale	RO	Specifies the scale used for the Slot Power Limit Value. Writes to this register also cause the Port to send the Set_Slot_Power_Limit message.	Yes	00b
17	EM_INTRELOCK Present	RO	When set, it indicates that an Electromechanical Interlock Present is implemented on the chassis for this slot.	Yes	0
18	No Command Completed Support	RO	When set, it indicates that this slot does not generate software notification when an issued command is completed by the Hot-Plug Controller.	Yes	0
31:19	Physical Slot Number	RO	It indicates the physical slot number attached to this Port.	Yes	01 h for Port 1 02h for Port 2 03h for Port 3 ...

9.3.49 SLOT CONTROL REGISTER – OFFSET 80h (Downstream Port Only)

BIT	FUNCTION	TYPE	DESCRIPTION	EEPROM/ I2C-SMBUS	DEFAULT
0	Attention Button Pressed Enable	RW	When set, it enables the generation of Hot-Plug interrupt or wakeup event on an attention button pressed event.	Yes	0
1	Power Fault Detected Enable	RW	When set, it enables the generation of Hot-Plug interrupt or wakeup event on a power fault event.	Yes	0
2	MRL SENOR ENABLE	RW	When set, it enables the generation of Hot-Plug interrupt or wakeup even.	Yes	0
3	Presence Detect Changed Enable	RW	When set, it enables the generation of Hot-Plug interrupt or wakeup event on a presence detect changed event.	Yes	0
4	Command Completed Interrupt Enable	RW	When set, it enables the generation of Hot-Plug interrupt when the Hot-Plug Controller completes a command. It is valid when offset 7Ch[18]=0b.	Yes	0
5	Hot-Plug Interrupt Enable	RW	When set, it enables generation of Hot-Plug interrupt on enabled Hot-Plug events.	Yes	0
7:6	Attention Indicator Control	RW	Controls the display of Attention Indicator. 00b: Reserved 01b: On 10b: Blink 11b: Off Writes to this register also cause the Port to send the ATTENTION_INDICATOR_* Messages.	Yes	11b
9:8	Power Indicator Control	RW	Controls the display of Power Indicator. 00b: Reserved 01b: On 10b: Blink 11b: Off Writes to this register also cause the Port to send the POWER_INDICATOR_* Messages.	Yes	11b if bit[2]=1 01b if bit[2]=0
10	Power Controller Control	RW	0b: reset the power state of the slot (Power On) 1b: set the power state of the slot (Power Off)	Yes	1 if bit[2]=1 0 if bit[2]=0
11	EM_INTRELOCK Control	RW	0b: no effect. 1b: cause the state of the interlock to toggle.	Yes	0
12	Data Link Layer State Changed Enable	RW	If the Data Link Layer Link Active capability is implemented, when set to 1b, this field enables software notification when Data Link Layer Link Active field is changed.	Yes	0
15:13	Reserved	RsvdP	Not support.	No	000b

9.3.50 SLOT STATUS REGISTER – OFFSET 80h (Downstream Port Only)

BIT	FUNCTION	TYPE	DESCRIPTION	EEPROM/ I2C-SMBUS	DEFAULT
16	Attention Button Pressed	RW1C	When set, it indicates the Attention Button is pressed.	Yes	0

BIT	FUNCTION	TYPE	DESCRIPTION	EEPROM/ I2C-SMBUS	DEFAULT
17	Power Fault Detected	RW1C	When set, it indicates a Power Fault is detected.	Yes	0
18	MRL Sensor Changed	RW1C	When set, it indicates a MRL Sensor Changed is detected.	Yes	0
19	Presence Detect Changed	RW1C	When set, it indicates a Presence Detect Changed is detected.	Yes	0
20	Command Completed	RW1C	When set, it indicates the Hot-Plug Controller completes an issued command.	Yes	0
21	MRL Sensor State	RO	Reflects the status of MRL Sensor. 0b: MRL Closed 1b: MRL Opened	No	0
22	Presence Detect State	RO	Indicates the presence of a card in the slot. 0b: Slot Empty 1b: Card Present in slot This register is implemented on all downstream ports that implement slots. For downstream ports not connected to slots (where the Slot Implemented bit of the PCI Express Capabilities register is 0b), this bit returns 1b.	No	0
23	EM_INTRELOCK Status	RO	Indicates the Electromechanical Interlock's current status. 0b: Electromechanical Interlock is disengaged 1b: Electromechanical Interlock is engaged	No	0
24	Data Link Layer State Changed	RW1C	This bit is set when the value reported in the Data Link Layer Link Active field of the Link Status register is changed.	Yes	0
31:25	Reserved	RsvdP	Not support.	No	0-0h

9.3.51 DEVICE CAPABILITIES REGISTER 2 – OFFSET 8Ch

BIT	FUNCTION	TYPE	DESCRIPTION	EEPROM/ I2C-SMBUS	DEFAULT
4:0	Reserved	RsvdP	Not support.	No	0_0000b
5	ARI Forwarding Supported	RO	0b: ARI forwarding is Not supported 1b: ARI forwarding is supported Valid for downstream ports only.	Yes	0 for Up 1 for Down
6	AtomicOp Routing Supported	RO	0b: AtomicOp Routing is Not supported 1b: AtomicOp Routing is supported	Yes	1
10:7	Reserved	RsvdP	Not support.	No	0-0h
11	LTR Mechanism Supported	RO	A value of 1b indicates support for the optional Latency Tolerance Reporting (LTR) mechanism. Valid for upstream port only.	Yes	0
17:12	Reserved	RsvdP	Not support.	No	0-0h
19:18	OBFF Supported	RO	This field indicates if OBFF is supported.	Yes	00b
31:20	Reserved	RsvdP	Not support.	No	000h

9.3.52 DEVICE CONTROL REGISTER 2 – OFFSET 90h

BIT	FUNCTION	TYPE	DESCRIPTION	EEPROM/ I2C-SMBUS	DEFAULT
4:0	Reserved	RsvdP	Not support.	No	0_0000b
5	ARI Forwarding Enable	RW	0b: Disable 1b: Enable Valid for downstream ports only.	Yes	0
6	AtomicOp Routing Enable	RW	0b: Disable 1b: Enable	Yes	0
7	Reserved	RsvdP	Not support.	No	0
9:8	Reserved	RsvdP	Not support.	No	00b

BIT	FUNCTION	TYPE	DESCRIPTION	EEPROM/ I2C-SMBUS	DEFAULT
10	LTR Mechansim Enable	RW	Enable LTR Mechanism	Yes	0
12:11	Reserved	RsvdP	Not support.	No	00b
14:13	OBFF Enable	RW	Enable OBFF Mechansim and select the signaling method.	Yes	00b
15	Reserved	RsvdP	Not support.	No	0

9.3.53 DEVICE STATUS REGISTER 2 – OFFSET 90h

BIT	FUNCTION	TYPE	DESCRIPTION	EEPROM/ I2C-SMBUS	DEFAULT
31:16	Reserved	RsvdP	Not support.	No	0000h

9.3.54 LINK CAPABILITIES REGISTER 2 – OFFSET 94h

BIT	FUNCTION	TYPE	DESCRIPTION	EEPROM/ I2C-SMBUS	DEFAULT
0	Reserved	RsvdP	Not support.	No	0
7:1	Supported Link Speeds Vector	RO	This field indicates the supported Link speed of the associated Port. bit[0]... 2.5 GT/s bit[1]... 5.0 GT/s bit[2]... 8.0 GT/s bit[6:3]... Reserved	Yes	0000_111b
8	Crosslink Supported	RO	0b: Crosslink is Not supported 1b: Crosslink is supported	Yes	0
31:9	Reserved	RsvdP	Not support.	No	0-0b

9.3.55 LINK CONTROL REGISTER 2 – OFFSET 98h

BIT	FUNCTION	TYPE	DESCRIPTION	EEPROM/ I2C-SMBUS	DEFAULT
3:0	Target Link Speed	RW	0001b: 2.5GT/s link speed is supported 0010b: 5.0GT/s link speed is supported 0011b: 8.0GT/s link speed is supported Others: reserved.	Yes	3h
4	Enter Compliance	RW	1b: enter compliance	Yes	0
5	HW_AutoSpeed_Dis	RW	When set, this bit disables hardware from changing the link speed for device-specific reasons other than attempting to correct unreliable link operation by reducing link speed.	Yes	0
6	Select_Deemp	RO	Valid for downstream ports only. 0b: Select -3.5db de-emphasis 1b: Select -6.0 db de-emphasis	Yes	0 for Up 1 for Down
9:7	Tran_Margin	RW	This field controls the value of the non-deemphasized voltage level at the transmitter pins.	Yes	000b
10	Enter Modify Compliance	RW	Valid for upstream port only. When set, the device transmits modified compliance pattern if the LTSSM enters Polling.Compliance substate.	Yes	0
11	Compliance SOS	RW	Valid for upstream port only. When set, the LTSSM is required to send SKP Ordered Sets between sequences when sending the Compliance Pattern or Modified Compliance Pattern.	Yes	0
15:12	Compliance Preset/De-emphasis	RW	This field is intended for debug and compliance testing purpose.	Yes	000b

9.3.56 LINK STATUS REGISTER 2 – OFFSET 98h

BIT	FUNCTION	TYPE	DESCRIPTION	EEPROM/ I2C-SMBUS	DEFAULT
16	Current De-emphasis level	RO	1b: -3.5dB 0b: -6 dB	No	1
17	Equalization Complete	RO	When set to 1b, this bit indicates that the Transmitter Equalization procedure has completed.	No	0
18	Equalization Phase 1 Successful	RO	When set to 1b, this bit indicates that Phase 1 of Transmitter Equalization procedure has successfully completed.	No	0
19	Equalization Phase 2 Successful	RO	When set to 1b, this bit indicates that Phase 2 of Transmitter Equalization procedure has successfully completed.	No	0
20	Equalization Phase 3 Successful	RO	When set to 1b, this bit indicates that Phase 3 of Transmitter Equalization procedure has successfully completed.	No	0
21	Link Equalization Request	RW1C	This bit is set by hardware to request the Link equalization process to be performed on the link.	Yes	0
27:22	Reserved	RsvdP	Not support.	No	0-0b
30:28	Downstream Component Presence	RO	This field indicates the presence and DRS status for the Downstream Component. 000b: Link Down – Presence Not Determined 001b: Link Down – Component Not Present 010b: Link Down – Component Present 011b: Reserved 100b: Link Up – Component Present 101b: Link Up – Component Present and DRS Received 110b: Reserved 111b: Reserved	No	000b
31	DRS Message Received	RW1C	This bit must be set whenever the Port receives a DRS message.	Yes	0

9.3.57 SLOT CAPABILITIES REGISTER 2 – OFFSET 9Ch

BIT	FUNCTION	TYPE	DESCRIPTION	EEPROM/ I2C-SMBUS	DEFAULT
31:0	Reserved	RsvdP	Not support.	No	0000_0000h

9.3.58 SLOT CONTROL REGISTER 2 – OFFSET A0h

BIT	FUNCTION	TYPE	DESCRIPTION	EEPROM/ I2C-SMBUS	DEFAULT
15:0	Reserved	RsvdP	Not support.	No	0000_0000h

9.3.59 SLOT STATUS REGISTER 2 – OFFSET A0h

BIT	FUNCTION	TYPE	DESCRIPTION	EEPROM/ I2C-SMBUS	DEFAULT
31:16	Reserved	RsvdP	Not support.	No	0000_0000h

9.3.60 SSID/SSVID CAPATILITIES REGISTER – OFFSET A4h

BIT	FUNCTION	TYPE	DESCRIPTION	EEPROM/ I2C-SMBUS	DEFAULT
7:0	SSID/SSVID Capabilities ID	RO	Read as 0Dh to indicate that this is SSID/SSVID capability register.	Yes	0Dh
15:8	Next Item Pointer	RO	Point to next PCI capability structure.	Yes	B0h for Up 00h for Down
31:16	Reserved	RsvdP	Not support.	No	0000h

9.3.61 SUBSYSTEM VENDOR ID REGISTER – OFFSET A8h

BIT	FUNCTION	TYPE	DESCRIPTION	EEPROM/ I2C-SMBUS	DEFAULT
15:0	SSVID	RO	It indicates the sub-system vendor id.	Yes	12D8h

9.3.62 SUBSYSTEM ID REGISTER – OFFSET A8h

BIT	FUNCTION	TYPE	DESCRIPTION	EEPROM/ I2C-SMBUS	DEFAULT
31:16	SSID	RO	It indicates the sub-system device id.	Yes	C016h

9.3.63 MSI-X CAPABILITIES REGISTER – OFFSET B0h (Upstream Port Only)

BIT	FUNCTION	TYPE	DESCRIPTION	EEPROM/ I2C-SMBUS	DEFAULT
7:0	MSI-X Capabilities ID	RO	Read as 11h to indicate that this is MSI-X capability register.	No	11h
15:8	Next Item Pointer	RO	Read as 00h. No other ECP registers.	Yes	00h
26:16	Table Size	RO	System software reads this field to determine the MSI-X Table Size N, which is encoded as N-1.	No	005h
29:27	Reserved	RsvdP	Not support.	No	000b
30	Function Mask	RW	If set, all of the vectors associated with the function are masked, regardless of their per-vector mask bit values. If clear, each vector's mask bit determines whether the vector is masked or not.	Yes	0
31	MSI-X Enable	RW	If set and the MSI Enable bit in the MSI Message Control register is clear, the function is permitted to use MSI-X to request service and is prohibited from using INTx interrupts (if implemented). If clear, the function is prohibited from using MSI-X to request service.	Yes	0

9.3.64 MSI-X TABLE OFFSET/TABLE BIR REGISTER – OFFSET B4h (Upstream Port Only)

BIT	FUNCTION	TYPE	DESCRIPTION	EEPROM/ I2C-SMBUS	DEFAULT
2:0	Table BIR	RO	Read as 000b to indicate Base Address 0 register (offset 10h in Configuration Space) is used to map the function MSI-X Table into Memory space.	Yes	000b
31:3	Table Offset	RO	Used as an offset from the address contained by one of the function's Base Address registers to point to the base of the MSI-X Table.	Yes	0000_FE00h

9.3.65 MSI- X PBA OFFSET / PBA BIR REGISTER – OFFSET B8h (Upstream Port Only)

BIT	FUNCTION	TYPE	DESCRIPTION	EEPROM/ I2C-SMBUS	DEFAULT
2:0	PBA BIR	RO	Read as 000b to indicate Base Address 0 register (offset 10h in Configuration Space) is used to map the function MSI-X PBA into Memory space.	Yes	000b
31:3	PBA Offset	RO	Used as an offset from the address contained by one of the function's Base Address registers to point to the base of the MSI-X PBA.	Yes	0000_FE10h

9.3.66 BAR 0 CONFIGURATION REGISTER – OFFSET E0h (Upstream Port Only)

BIT	FUNCTION	TYPE	DESCRIPTION	EEPROM/ I2C-SMBUS	DEFAULT
0	Type Selector	RsvdP	Not supported.	No	0

BIT	FUNCTION	TYPE	DESCRIPTION	EEPROM/ I2C-SMBUS	DEFAULT
2:1	BAR 0 Type	RW	00b: BAR0 is implemented as a 32 bit Memory BAR 10b: BAR0/1 is implemented as a 64-bit Memory BAR	Yes	00b
3	Prefetchable	RW	0b: Non Prefetchable 1b: Prefetchable	Yes	0
18:4	Reserved	RsvdP	Not supported.	No	0-0b
30:19	BAR 0 Size	RW	To specify BAR0 size. 0b: Corresponding BAR0 bits are RO bits that always return 0 1b: Corresponding BAR0 bits are RW bits	Yes	FFFh
31	BAR 0 Enable	RW	bit[2:1]=00b 0b: Disable BAR0 1b: Enable BAR0	Yes	1
	BAR 0 Size	RW	bit[2:1]=10b Includes with bit[30:19] when this BAR is used as a 64-bit BAR (bit[2:1]=10b).		

9.3.67 BAR 0-1 CONFIGURATION REGISTER – OFFSET E4h (Upstream Port Only)

BIT	FUNCTION	TYPE	DESCRIPTION	EEPROM/ I2C-SMBUS	DEFAULT
0	Type Selector	RsvdP	E0h[2:1]=00b Not support.	No	0
		RW	E0h[2:1]=10b BAR0/1 are used as a 64-bit BAR, bit[31:0] are used as the upper 32-bits.	Yes	0
2:1	BAR 1 Type	RO	E0h[2:1]=00b 00b: BAR1 is implemented as 32 bit Memory BAR.	No	00b
		RW	E0h[2:1]=10b BAR0/1 are used as a 64-bit BAR, bit[31:0] are used as the upper 32-bits.	Yes	00b
3	Prefetchable	RW	E0h[2:1]=00b 0b: Non Prefetchable 1b: Prefetchable	Yes	0
		RW	E0h[2:1]=10b BAR0/1 are used as a 64-bit BAR, bit[31:0] are used as the upper 32-bits.		
4	Reserved	RsvdP	E0h[2:1]=00b Not support.	No	0
		RW	E0h[2:1]=10b BAR0/1 are used as a 64-bit BAR, bit[31:0] are used as the upper 32-bits.	Yes	0
8:5	Domain ID	RW	E0h[2:1]=00b The valid number is from 0 to 1.	Yes	0000b
		RW	E0h[2:1]=10b BAR0/1 are used as a 64-bit BAR, bit[31:0] are used as the upper 32-bits.		
19:9	Reserved	RsvdP	E0h[2:1]=00b Not support.	No	0-0b
		RW	E0h[2:1]=10b BAR0/1 are used as a 64-bit BAR, bit[31:0] are used as the upper 32-bits.	Yes	0-0b
30:20	BAR 1 Size	RW	To specify BAR1 size. 0b: Corresponding BAR1 bits are RO bits that always return 0 1b: Corresponding BAR1 bits are RW bits	Yes	000h
31	BAR 1 Enable	RW	E0h[2:1]=00b 0b: Disable BAR1 1b: Enable BAR1	Yes	0
	64-Bit BAR	RW	E0h[2:1]=10b 0b: BAR0/1 is disabled, all BAR0/1 bits read 0. 1b: BAR0/1 is enabled as a 64-bit BAR.		

9.3.68 PCI EXPRESS ADVANCED ERROR REPORTING ENHANCED CAPABILITY HEADER REGISTER – OFFSET 100h

BIT	FUNCTION	TYPE	DESCRIPTION	EEPROM/ I2C-SMBUS	DEFAULT
15:0	Extended Capabilities ID	RO	Read as 0001h to indicate that this is PCI express extended capability register for advance error reporting.	No	0001h
19:16	Capability Version	RO	Read as 1h.	No	1h
31:20	Next Capability Offset	RO	Point to next PCI extended capability structure.	Yes	130h

9.3.69 UNCORRECTABLE ERROR STATUS REGISTER – OFFSET 104h

BIT	FUNCTION	TYPE	DESCRIPTION	EEPROM/ I2C-SMBUS	DEFAULT
0	Training Error Status	RW1C	When set, indicates that the Training Error event has occurred.	Yes	0
3:1	Reserved	RsvdP	Not support.	No	000b
4	Data Link Protocol Error Status	RW1C	When set, indicates that the Data Link Protocol Error event has occurred.	Yes	0
5	Surprise Down Error Status	RW1C	When set, indicates that the Surprise Down Error event has occurred. Valid for Downstream ports only.	Yes	0
11:6	Reserved	RsvdP	Not support.	No	0-0b
12	Poisoned TLP Status	RW1C	When set, indicates that a Poisoned TLP has been received or generated.	Yes	0
13	Flow Control Protocol Error Status	RW1C	When set, indicates that the Flow Control Protocol Error event has occurred.	Yes	0
14	Completion Timeout Status	RW1C	When set, indicates that the Completion Timeout event has occurred.	Yes	0
15	Completer AbortStatus	RW1C	When set, indicates that the Completer Abort event has occurred.	Yes	0
16	Unexpected Completion Status	RW1C	When set, indicates that the Unexpected Completion event has occurred.	Yes	0
17	Receiver Overflow Status	RW1C	When set, indicates that the Receiver Overflow event has occurred.	Yes	0
18	Malformed TLP Status	RW1C	When set, indicates that a Malformed TLP has been received.	Yes	0
19	ECRC Error Status	RW1C	When set, indicates that an ECRC Error has been detected.	Yes	0
20	Unsupported Request Error Status	RW1C	When set, indicates that an Unsupported Request event has occurred.	Yes	0
21	ACS Violation Status	RW1C	When set, indicates that an ACS Violation event has occurred. Valid for Downstream ports only.	Yes	0
22	Internal Error Status	RW1C	When set, indicates that an internal error event has occurred.	Yes	0
23	MC Blocked TLP Status	RW1C	When set, indicates that an MC Blocked TLP event has occurred.	Yes	0
24	AtomicOp Egress Blocked Status	RW1C	When set, indicates that an AtomicOp Egress Blocked event has occurred.	Yes	0
31:25	Reserved	RsvdP	Not support.	No	0000_000b

9.3.70 UNCORRECTABLE ERROR MASK REGISTER – OFFSET 108h

BIT	FUNCTION	TYPE	DESCRIPTION	EEPROM/ I2C-SMBUS	DEFAULT
0	Training Error Mask	RW	When set, the Training Error event is not logged in the Header Log register and not issued as an Error Message to RC either.	Yes	0
3:1	Reserved	RsvdP	Not support.	No	000b
4	Data Link Protocol Error Mask	RW	When set, the Data Link Protocol Error event is not logged in the Header Log register and not issued as an Error Message to RC either.	Yes	0
5	Surprise Down Error Mask	RW	When set, Surprise Down Error event is not logged in the Header Log register and not issued as an Error Message to RC either. Valid for Downstream ports only.	Yes	0
11:6	Reserved	RsvdP	Not support.	No	0-0b
12	Poisoned TLP Mask	RW	When set, an event of Poisoned TLP has been received or generated is not logged in the Header Log register and not issued as an Error Message to RC either.	Yes	0
13	Flow Control Protocol Error Mask	RW	When set, the Flow Control Protocol Error event is not logged in the Header Log register and not issued as an Error Message to RC either.	Yes	0
14	Completion Timeout Mask	RW	When set, the Completion Timeout event is not logged in the Header Log register and not issued as an Error Message to RC either.	Yes	0

BIT	FUNCTION	TYPE	DESCRIPTION	EEPROM/ I2C-SMBUS	DEFAULT
15	Completer AbortMask	RW	When set, the Completer Abort event is not logged in the Header Log register and not issued as an Error Message to RC either.	Yes	0
16	Unexpected Completion Mask	RW	When set, the Unexpected Completion event is not logged in the Header Log register and not issued as an Error Message to RC either.	Yes	0
17	Receiver Overflow Mask	RW	When set, the Receiver Overflow event is not logged in the Header Log register and not issued as an Error Message to RC either.	Yes	0
18	Malformed TLP Mask	RW	When set, an event of Malformed TLP has been received is not logged in the Header Log register and not issued as an Error Message to RC either.	Yes	0
19	ECRC Error Mask	RW	When set, an event of ECRC Error has been detected is not logged in the Header Log register and not issued as an Error Message to RC either.	Yes	0
20	Unsupported Request Error Mask	RW	When set, the Unsupported Request event is not logged in the Header Log register and not issued as an Error Message to RC either.	Yes	0
21	ACS Violation Mask	RW	When set, the ACS Violation event is not logged in the Header Log register and not issued as an Error Message to RC either. Valid for Downstream ports only.	Yes	0
22	Internal Error Mask	RW	When set, the Internal Error has been detected is not logged in the Header Log register and not issued as an Error Message to RC either.	Yes	1
23	MC Blocked TLP Mask	RW	When set, the MC Blocked TLP event is not logged in the Header Log register and not issued as an Error Message to RC either.	Yes	0
24	AtomicOp Egress Blocked Mask	RW	When set, the AtomicOp Egress Blocked event is not logged in the Header Log register and not issued as an Error Message to RC either.	Yes	0
31:25	Reserved	RsvdP	Not support.	No	0000_000b

9.3.71 UNCORRECTABLE ERROR SEVERITY REGISTER – OFFSET 10Ch

BIT	FUNCTION	TYPE	DESCRIPTION	EEPROM/ I2C-SMBUS	DEFAULT
0	Training Error Severity	RW	0b: Non-Fatal 1b: Fatal	Yes	1
3:1	Reserved	RsvdP	Not support.	No	000b
4	Data Link Protocol Error Severity	RW	0b: Non-Fatal 1b: Fatal	Yes	1
5	Surprise Down Error Severity	RW	0b: Non-Fatal 1b: Fatal Valid for Downstream ports only.	Yes	0 for Up 1 for Down
11:6	Reserved	RsvdP	Not support.	No	0-0b
12	Poisoned TLP Severity	RW	0b: Non-Fatal 1b: Fatal	Yes	0
13	Flow Control Protocol Error Severity	RW	0b: Non-Fatal 1b: Fatal	Yes	1
14	Completion Timeout Error Severity	RW	0b: Non-Fatal 1b: Fatal	Yes	0
15	Completer AbortSeverity	RW	0b: Non-Fatal 1b: Fatal	Yes	0
16	Unexpected Completion Severity	RW	0b: Non-Fatal 1b: Fatal	Yes	0
17	Receiver Overflow Severity	RW	0b: Non-Fatal 1b: Fatal	Yes	1
18	Malformed TLP Severity	RW	0b: Non-Fatal 1b: Fatal	Yes	1
19	ECRC Error Severity	RW	0b: Non-Fatal 1b: Fatal	Yes	0
20	Unsupported Request Error Severity	RW	0b: Non-Fatal 1b: Fatal	Yes	0

BIT	FUNCTION	TYPE	DESCRIPTION	EEPROM/ I2C-SMBUS	DEFAULT
21	ACS Violation Severity	RW	0b: Non-Fatal 1b: Fatal Valid for Downstream ports only.	Yes	0
22	Internal Error Severity	RW	0b: Non-Fatal 1b: Fatal	Yes	1
23	MC Blocked TLP Severity	RW	0b: Non-Fatal 1b: Fatal	Yes	0
24	AtomicOp Egress Blocked Severity	RW	0b: Non-Fatal 1b: Fatal	Yes	0
31:25	Reserved	RsvdP	Not support.	No	0000_000b

9.3.72 CORRECTABLE ERROR STATUS REGISTER – OFFSET 110h

BIT	FUNCTION	TYPE	DESCRIPTION	EEPROM/ I2C-SMBUS	DEFAULT
0	Receiver Error Status	RW1C	When set, the Receiver Error event is detected.	Yes	0
5:1	Reserved	RsvdP	Not support.	No	0_000b
6	Bad TLP Status	RW1C	When set, the event of Bad TLP has been received is detected.	Yes	0
7	Bad DLLP Status	RW1C	When set, the event of Bad DLLP has been received is detected.	Yes	0
8	REPLAY_NUM Rollover Status	RW1C	When set, the REPLAY_NUM Rollover event is detected.	Yes	0
11:9	Reserved	RsvdP	Not support.	No	000b
12	Replay Timer Timeout Status	RW1C	When set, the Replay Timer Timeout event is detected.	Yes	0
13	Advisory Non-Fatal Error Status	RW1C	When set, the Advisory Non-Fatal Error event is detected.	Yes	0
14	Corrected Internal Error Status	RW1C	When set, the Corrected Internal Error event is detected.	Yes	0
31:15	Reserved	RsvdP	Not support.	No	0-0h

9.3.73 CORRECTABLE ERROR MASK REGISTER – OFFSET 114h

BIT	FUNCTION	TYPE	DESCRIPTION	EEPROM/ I2C-SMBUS	DEFAULT
0	Receiver Error Mask	RW	When set, the Receiver Error event is not logged in the Header Log register and not issued as an Error Message to RC either.	Yes	0
5:1	Reserved	RsvdP	Not support.	No	0_000b
6	Bad TLPMask	RW	When set, the event of Bad TLP has been received is not logged in the Header Log register and not issued as an Error Message to RC either.	Yes	0
7	Bad DLLP Mask	RW	When set, the event of Bad DLLP has been received is not logged in the Header Log register and not issued as an Error Message to RC either.	Yes	0
8	REPLAY_NUM Rollover Mask	RW	When set, the REPLAY_NUM Rollover event is not logged in the Header Log register and not issued as an Error Message to RC either.	Yes	0
11:9	Reserved	RsvdP	Not support.	No	000b
12	Replay Timer Timeout Mask	RW	When set, the Replay Timer Timeout event is not logged in the Header Log register and not issued as an Error Message to RC either.	Yes	0
13	Advisory Non-Fatal Error Mask	RW	When set, the Advisory Non-Fatal Error event is not logged in the Header Long register and not issued as an Error Message to RC either.	Yes	1
14	Corrected Internal Error Mask	RW	When set, the corrected internal error event is not logged in the Header Log register and not issued as an Error Message to RC either.	Yes	1
31:15	Reserved	RsvdP	Not support.	No	0-0h

9.3.74 ADVANCE ERROR CAPABILITIES AND CONTROL REGISTER – OFFSET 118h

BIT	FUNCTION	TYPE	DESCRIPTION	EEPROM/ I2C-SMBUS	DEFAULT
4:0	First Error Pointer	RO	It indicates the bit position of the first error reported in the Uncorrectable Error Status register.	No	0_0000b
5	ECRC Generation Capable	RO	When set, it indicates the Switch has the capability to generate ECRC.	Yes	1
6	ECRC Generation Enable	RW	When set, it enables the generation of ECRC when needed.	Yes	0
7	ECRC Check Capable	RO	When set, it indicates the Switch has the capability to check ECRC.	Yes	1
8	ECRC Check Enable	RW	When set, the function of checking ECRC is enabled..	Yes	0
31:9	Reserved	RsvdP	Not support.	No	0-0h

9.3.75 HEADER LOG REGISTER – OFFSET From 11Ch to 128h

BIT	FUNCTION	TYPE	DESCRIPTION	EEPROM/ I2C-SMBUS	DEFAULT
31:0	1 st DWORD	RO	Hold the 1st DWORD of TLP Header. The Head byte is in big endian.	No	0000_0000h
63:32	2 nd DWORD	RO	Hold the 2nd DWORD of TLP Header. The Head byte is in big endian.	No	0000_0000h
95:64	3 rd DWORD	RO	Hold the 3rd DWORD of TLP Header. The Head byte is in big endian.	No	0000_0000h
127:96	4 th DWORD	RO	Hold the 4th DWORD of TLP Header. The Head byte is in big endian.	No	0000_0000h

9.3.76 PCI EXPRESS VIRTUAL CHANNEL ENHANCED CAPABILITYHEADER REGISTER – OFFSET 130h

BIT	FUNCTION	TYPE	DESCRIPTION	EEPROM/ I2C-SMBUS	DEFAULT
15:0	Extended Capabilities ID	RO	Read as 02h to indicate that this is PCI express extended capability register for virtual channel.	No	02h
19:16	Capability Version	RO	Read as 1h.	No	01h
31:20	Next Capability Offset	RO	Point to next PCI extended capability structure.	Yes	1A0h

9.3.77 PORT VC CAPABILITY REGISTER 1 – OFFSET 134h

BIT	FUNCTION	TYPE	DESCRIPTION	EEPROM/ I2C-SMBUS	DEFAULT
2:0	Extended VC Count	RO	It indicates the number of extended Virtual Channels in addition to the default VC supported by the Switch.	No	000b
3	Reserved	RO	Not support.	No	0
6:4	Low Priority Extended VC Count	RO	It indicates the number of extended Virtual Channels in addition to the default VC belonging to the low-priority VC (LPVC) group.	No	000b
7	Reserved	RO	Not support.	No	0
9:8	Reference Clock	RO	It indicates the reference clock for Virtual Channels that support time-based WRR Port Arbitration. Defined encoding is 00b for 100ns reference clock.	No	00b
11:10	Port Arbitration Table Entry Size	RO	Read as 10b to indicate the size of Port Arbitration table entry in the device is 4 bits.	No	10b
31:12	Reserved	RsvdP	Not support.	No	0000_0h

9.3.78 PORT VC CAPABILITY REGISTER 2 – OFFSET 138h

BIT	FUNCTION	TYPE	DESCRIPTION	EEPROM/ I2C-SMBUS	DEFAULT
7:0	VC Arbitration Capability	RO	It indicates the types of VC Arbitration supported by the device for the LPVC group. This field is valid when LPVC is greater than 0. The Switch supports Hardware fixed arbitration scheme, e.g., Round Robin and Weight Round Robin arbitration with 32 phases in LPVC.	No	00h
23:8	Reserved	RsvdP	Not support.	No	0000h
31:24	VC Arbitration Table Offset	RO	It indicates the location of the VC Arbitration Table as an offset from the base address of the Virtual Channel Capability register in the unit of DQWD (16 bytes).	No	00h

9.3.79 PORT VC CONTROL REGISTER – OFFSET 13Ch

BIT	FUNCTION	TYPE	DESCRIPTION	EEPROM/ I2C-SMBUS	DEFAULT
0	Load VC Arbitration Table	WO	When set, the programmed VC Arbitration Table is applied to the hardware. This bit always returns 0b when read.	Yes	0
3:1	VC Arbitration Select	RW	This field is used to configure the VC Arbitration by selecting one of the supported VC Arbitration schemes. The valid values for the schemes supported by Switch are 0b and 1b. Other value than these written into this register will be treated as default.	Yes	000b
15:4	Reserved	RsvdP	Not support.	No	000h

9.3.80 PORT VC STATUS REGISTER – OFFSET 13Ch

BIT	FUNCTION	TYPE	DESCRIPTION	EEPROM/ I2C-SMBUS	DEFAULT
16	VC Arbitration Table Status	RO	When set, it indicates that any entry of the VC Arbitration Table is written by software. This bit is cleared when hardware finishes loading values stored in the VC Arbitration Table after the bit of “Load VC Arbitration Table” is set.	No	0
31:17	Reserved	RsvdP	Not support.	No	0-0h

9.3.81 VC RESOURCE CAPABILITY REGISTER (0) – OFFSET 140h

BIT	FUNCTION	TYPE	DESCRIPTION	EEPROM/ I2C-SMBUS	DEFAULT
7:0	Port Arbitration Capability	RO	It indicates the types of Port Arbitration supported by the VC resource. The Switch supports Round Robin Hardware fixed arbitration scheme.	No	01h
13:8	Reserved	RsvdP	Not support.	No	00_0000h
14	Advanced Packet Switching	RO	When set, it indicates the VC resource only supports transaction optimized for Advanced Packet Switching (AS).	No	0
15	Reject Snoop Transactions	RsvdP	Not support.	No	0
22:16	Maximum Time Slots	RO	It indicates the maximum numbers of time slots (minus one) are allocated for Isochronous traffic.	No	3Fh
23	Reserved	RsvdP	Not support.	No	0
31:24	Port Arbitration Table Offset	RO	It indicates the location of the Port Arbitration Table (n) as an offset from the base address of the Virtual Channel Capability register in the unit of DQWD (16 bytes).	No	05h

9.3.82 VC RESOURCE CONTROL REGISTER (0) – OFFSET 144h

BIT	FUNCTION	TYPE	DESCRIPTION	EEPROM/ I2C-SMBUS	DEFAULT
7:0	TC/VC Map	RW	This field indicates the TCs that are mapped to the VC resource. Bit locations within this field correspond to TC values. When the bits in this field are set, it means that the corresponding TCs are mapped to the VC resource. Bit 0 of this field is read-only and must be set to “1” for the VC0.	Yes	FFh
15:8	Reserved	RsvdP	Not support.	No	00h
16	Load Port Arbitration Table	RW	When set, the programmed Port Arbitration Table is applied to the hardware. This bit always returns 0b when read.	Yes	0
19:17	Port Arbitration Select	RW	This field is used to configure the Port Arbitration by selecting one of the supported Port Arbitration schemes. The permissible values for the schemes supported by Switch are 000b and 011b at VC0, other value than these written into this register will be treated as default.	Yes	000b
23:20	Reserved	RsvdP	Not support.	No	0h
26:24	VC ID	RO	This field assigns a VC ID to the VC resource.	No	000b
30:27	Reserved	RsvdP	Not support.	No	0h
31	VC Enable	RW	0b: it disables this Virtual Channel 1b: it enables this Virtual Channel	Yes	1

9.3.83 VC RESOURCE STATUS REGISTER (0) – OFFSET 148h

BIT	FUNCTION	TYPE	DESCRIPTION	EEPROM/ I2C-SMBUS	DEFAULT
15:0	Reserved	RsvdP	Not support.	No	0000h
16	Port Arbitration Table Status	RO	When set, it indicates that any entry of the Port Arbitration Table is written by software. This bit is cleared when hardware finishes loading values stored in the Port Arbitration Table after the bit of “Load Port Arbitration Table” is set.	No	0
17	VC Negotiation Pending	RO	When set, it indicates that the VC resource is still in the process of negotiation. This bit is cleared after the VC negotiation is complete.	No	1
31:18	Reserved	RsvdP	Not support.	No	0-0h

9.3.84 DEVICE SERIAL NUMBER ENHANCED CAPABILITY HEADER REGISTER – OFFSET 1A0h

BIT	FUNCTION	TYPE	DESCRIPTION	EEPROM/ I2C-SMBUS	DEFAULT
15:0	Extended Capabilities ID	RO	Read as 0003h to indicate that this is PCI express extended capability register for device serial number.	No	0003h
19:16	Capability Version	RO	Must be 1h for this version.	No	1h
31:20	Next Capability Offset	RO	Point to next PCI extended capability structure.	Yes	1B0h for Up 1C0h for Down

9.3.85 DEVICE SERIAL NUMBER LOWER DW REGISTER – OFFSET 1A4h

BIT	FUNCTION	TYPE	DESCRIPTION	EEPROM/ I2C-SMBUS	DEFAULT
31:0	Device serial number 1 st DW	RO	First dword for device serial number.	Yes	0000_12D8h

9.3.86 DEVICE SERIAL NUMBER HIGHER DW REGISTER – OFFSET 1A8h

BIT	FUNCTION	TYPE	DESCRIPTION	EEPROM/ I2C-SMBUS	DEFAULT
31:0	Device serial number 2 nd DW	RO	2 nd dword for device serial number.	Yes	0816_4896h

9.3.87 PCI EXPRESS POWER BUDGETING ENHANCED CAPABILITY HEADER REGISTER – OFFSET 1B0h (Upstream Port Only)

BIT	FUNCTION	TYPE	DESCRIPTION	EEPROM/ I2C-SMBUS	DEFAULT
15:0	Extended Capabilities ID	RO	Read as 0004h to indicate that this is PCI express extended capability register for power budgeting.	No	0004h
19:16	Capability Version	RO	Must be 1h for this version.	No	01h
31:20	Next Capability Offset	RO	Point to next PCI extended capability structure.	Yes	1D0h

9.3.88 DATA SELECT REGISTER – OFFSET 1B4h (Upstream Port Only)

BIT	FUNCTION	TYPE	DESCRIPTION	EEPROM/ I2C-SMBUS	DEFAULT
7:0	Data Selection	RW	It indexes the power budgeting data reported through the data register. When 00h, it selects D0 Max power budget When 01h, it selects D0 Sustained power budget Other values would return zero power budgets, which means Not supported.	Yes	00h
31:8	Reserved	RsvdP	Not support.	No	0-0h

9.3.89 POWER BUDGETING DATA REGISTER – OFFSET 1B8h (Upstream Port Only)

BIT	FUNCTION	TYPE	DESCRIPTION	EEPROM/ I2C-SMBUS	DEFAULT
7:0	Base Power	RO	It specifies the base power value in watts. This value represents the required power budget in the given operation condition.	Yes	04h if 13Ch.bit[0]=0 03h if 13Ch.bit[0]=1
9:8	Data Scale	RO	It specifies the scale to apply to the base power value.	Yes	00b
12:10	PM Sub State	RO	It specifies the power management sub state of the given operation condition. It is initialized to the default sub state.	Yes	000b
14:13	PM State	RO	It specifies the power management state of the given operation condition. It defaults to the D0 power state.	Yes	00b
17:15	Type	RO	It specifies the type of the given operation condition which is controlled by offset 13Ch[7:0] . It defaults to the Maximum power state.	Yes	7h if 13Ch.bit[0]=0 3h if 13Ch.bit[0]=1
20:18	Power Rail	RO	It specifies the power rail of the given operation condition.	Yes	010b
31:21	Reserved	RsvdP	Not support.	No	0-0h

9.3.90 POWER BUDGET CAPABILITY REGISTER – OFFSET 1BCh (Upstream Port Only)

BIT	FUNCTION	TYPE	DESCRIPTION	EEPROM/ I2C-SMBUS	DEFAULT
0	System Allocated	RO	When set, it indicates that the power budget for the device is included within the system power budget.	Yes	1
31:1	Reserved	RsvdP	Not support.	No	0-0h

9.3.91 ACS ENHANCED CAPABILITY HEADER REGISTER – OFFSET 1C0h (Downstream Port Only)

BIT	FUNCTION	TYPE	DESCRIPTION	EEPROM/ I2C-SMBUS	DEFAULT
15:0	PCI Express Extended Capability ID	RO	Read as 000Dh to indicate that this is PCI Express Extended Capability register for ACS.	No	000Dh

BIT	FUNCTION	TYPE	DESCRIPTION	EEPROM/ I2C-SMBUS	DEFAULT
19:16	Capability Version	RO	Must be 1h for this version.	No	1h
31:20	Next Capability ID	RO	Point to next PCI extended capability structure.	Yes	1D0h

9.3.92 ACS CAPABILITY REGISTER – OFFSET 1C4h (Downstream Port Only)

BIT	FUNCTION	TYPE	DESCRIPTION	EEPROM/ I2C-SMBUS	DEFAULT
0	ACS Source Validation	RO	Indicated the implements of ACS Source Validation.	Yes	1
1	ACS Translation Blocking	RO	Indicated the implements of ACS Translation Blocking.	Yes	1
2	ACS P2P Request Redirect	RO	Indicated the implements of ACS P2P Request Redirect.	Yes	1
3	ACS P2P Completion Redirect	RO	Indicated the implements of ACS P2P Completion Redirect	Yes	1
4	ACS Upstream Forwarding	RO	Indicated the implements of ACS Upstream Forwarding.	Yes	1
5	ACS P2P Egress control	RO	Indicated the implements of ACS P2P Egress control.	Yes	1
6	ACS Direct Translated P2P	RO	Indicated the implements of ACS Direct Translated P2P.	Yes	1
7	Reserved	RsvdP	Not support.	No	0
15:8	Egress Control Vector Size	RO	Encodings 01h – FFh directly indicate the number of applicable bits in theEgress Control Vector.	Yes	10h
16	ACS Source Validation Enable	RW	Enable the source validation.	Yes	0
17	ACS Translation Blocking Enable	RW	Enable ACS Translation Blocking.	Yes	0
18	ACS P2P Request Redirect	RW	Enable ACS P2P Request Redirect.	Yes	0
19	ACS P2P Completion Redirect Enable	RW	Enable ACS P2P Completion Redirect.	Yes	0
20	ACS Upstream Forwarding Enable	RW	Enable ACS Upstream Forwarding.	Yes	0
21	ACS P2P Egress control Enable	RW	Enable ACS P2P Egress control.	Yes	0
22	ACS Direct Translated P2P Enable	RW	Enable ACS Direct Translated P2P.	Yes	0
31:23	Reserved	RsvdP	Not support.	No	00h

9.3.93 EGRESS CONTROL VECTOR REGISTER – OFFSET 1C8h (Downstream Port Only)

BIT	FUNCTION	TYPE	DESCRIPTION	EEPROM/ I2C-SMBUS	DEFAULT
15:0	Egress Control Vector	RW	When a given bit is set, peer-to-peer requests targeting the associated Port are blocked or redirected.	Yes	0000h
31:16	Reserved	RsvdP	Not support.	No	0000h

9.3.94 MULTI-CAST ENHANCED CAPABILITY HEADER REGISTER – OFFSET 1D0h

BIT	FUNCTION	TYPE	DESCRIPTION	EEPROM/ I2C-SMBUS	DEFAULT
15:0	Extended Capabilities ID	RO	Read as 0012h to indicate that this is PCI express extended capability register for multi-cast.	No	0012h
19:16	Capability Version	RO	Read as 1h.	No	1h
31:20	Next Capability Offset	RO	Point to next PCI extended capability structure.	Yes	210h if 8Ch.bit[11] =0 200h if 8Ch.bit[11] =1

9.3.95 MULTI-CAST CAPABILITY REGISTER – OFFSET 1D4h

BIT	FUNCTION	TYPE	DESCRIPTION	EEPROM/ I2C-SMBUS	DEFAULT
5:0	MC_Max_Group	RO	Value indicates the max. number of Multicast Groups that the component supports.	No	11_1111b
14:6	Reserved	RO	Not support.	No	0
15	MC_ECRC_Regeneration_Supported	RO	If set, indicates that ECRC regeneration is supported.	No	0

9.3.96 MULTI-CAST CONTROL REGISTER – OFFSET 1D4h

BIT	FUNCTION	TYPE	DESCRIPTION	EEPROM/ I2C-SMBUS	DEFAULT
21:16	MC_Num_Group	RW	Value indicates the number of Multicast Groups configured for use.	Yes	00_0000b
30:22	Reserved	RsvdP	Not support.	No	0-0h
31	MC_Enable	RW	When set, the Multicast mechanism is enabled for the component.	Yes	0

9.3.97 MULTI-CAST BASE ADDRESS 0 REGISTER – OFFSET 1D8h

BIT	FUNCTION	TYPE	DESCRIPTION	EEPROM/ I2C-SMBUS	DEFAULT
5:0	MC_Index_Position	RW	The location of the LSB of the Multicast Group number within the address.	Yes	00h
11:6	Reserved	RsvdP	Not support.	No	00h
31:12	MC_Base_Address [31:12]	RW	The base address of the Multicast address range.	Yes	0-0h

9.3.98 MULTI-CAST BASE ADDRESS 1 REGISTER – OFFSET 1DCh

BIT	FUNCTION	TYPE	DESCRIPTION	EEPROM/ I2C-SMBUS	DEFAULT
31:0	MC_Base_Address [63:32]	RW	The base address of the Multicast address range.	Yes	0000-0000h

9.3.99 MULTI-CAST RECEIVER REGISTER – OFFSET 1E0h

BIT	FUNCTION	TYPE	DESCRIPTION	EEPROM/ I2C-SMBUS	DEFAULT
31:0	MC_Receive[31:0]	RW	For each bit that's set, this Function gets a copy of any Multicast TLPs for the associated Multicast Group.	Yes	0000_0000h

9.3.100 MULTI-CAST RECEIVER UPPER 32-BITS REGISTER – OFFSET 1E4h

BIT	FUNCTION	TYPE	DESCRIPTION	EEPROM/ I2C-SMBUS	DEFAULT
31:0	MC_Receive[63:32]	RW	For each bit that's set, this Function gets a copy of any Multicast TLPs for the associated Multicast Group.	Yes	0000_0000h

9.3.101 MULTI-CAST BLOCK ALL REGISTER – OFFSET 1E8h

BIT	FUNCTION	TYPE	DESCRIPTION	EEPROM/ I2C-SMBUS	DEFAULT
31:0	MC_Block_All[31:0]	RW	For each bit that is set, this Function is blocked from sending TLPs to the associated Multicast Group.	Yes	0000_0000h

9.3.102 MULTI-CAST BLOCK ALL UPPER 32-BITS REGISTER – OFFSET 1ECh

BIT	FUNCTION	TYPE	DESCRIPTION	EEPROM/ I2C-SMBUS	DEFAULT
31:0	MC_Block_All[63:32]	RW	For each bit that is set, this Function is blocked from sending TLPs to the associated Multicast Group.	Yes	0000_0000h

9.3.103 MULTI-CAST BLOCK UNTRANSLATED REGISTER – OFFSET 1F0h

BIT	FUNCTION	TYPE	DESCRIPTION	EEPROM/ I2C-SMBUS	DEFAULT
31:0	MC_Block_Untranslated[31:0]	RW	For each bit that is set, this Function is blocked from sending TLPs containing Untranslated Addresses to the associated MCG.	Yes	0000_0000h

9.3.104 MULTI-CAST BLOCK UNTRANSLATED UPPER 32-BITS REGISTER – OFFSET 1F4h

BIT	FUNCTION	TYPE	DESCRIPTION	EEPROM/ I2C-SMBUS	DEFAULT
31:0	MC_Block_Untranslated[63:32]	RW	For each bit that is set, this Function is blocked from sending TLPs containing Untranslated Addresses to the associated MCG.	Yes	0000_0000h

9.3.105 LTR EXTENDED CAPABILITY HEADER – OFFSET 200h (Upstream Port Only)

BIT	FUNCTION	TYPE	DESCRIPTION	EEPROM/ I2C-SMBUS	DEFAULT
15:0	PCI Express Extended Capability ID	RO	Read as 0018h to indicate that this is PCI Express Extended Capability register for LTR.	No	0018h if 8Ch.bit[11] =1 0000h if 8Ch.bit[11] =0
19:16	Capability Version	RO	Must be 1h for this version.	No	1h if 8Ch.bit[11] =1 0h if 8Ch.bit[11] =0
31:20	Next Capability ID	RO	Point to next PCI extended capability structure.	Yes	210h if 8Ch.bit[11] =1 000h if 8Ch.bit[11] =0

9.3.106 MAX SNOOP LATENCY REGISTER – OFFSET 204h (Upstream Port Only)

BIT	FUNCTION	TYPE	DESCRIPTION	EEPROM/ I2C-SMBUS	DEFAULT
9:0	Max Snoop Latency Value	RW	Specifies the maximumsnoop latency that a device is permitted to request	Yes	0D0h if 8Ch.bit[11] =1 000h if 8Ch.bit[11] =0
12:10	Max Snoop Latency Scale	RW	This register provides a scalefor the value contained within the Maximum SnoopLatencyValue field	Yes	000b
15:13	Reserved	RsvdP	Not support.	No	000b

9.3.107 MAX NO-SNOOP LATENCY REGISTER – OFFSET 204h (Upstream Port Only)

BIT	FUNCTION	TYPE	DESCRIPTION	EEPROM/ I2C-SMBUS	DEFAULT
25:16	Max No-Snoop Latency Value	RW	Specifies the maximum no-snoop latency that a device is permitted to request	Yes	0D0h if 8Ch.bit[11] =1 000h if 8Ch.bit[11] =0
28:26	Max No-Snoop Latency Scale	RW	This register provides a scalefor the value contained within the Maximum No-SnoopLatencyValue field	Yes	000b
31:29	Reserved	RsvdP	Not support.	No	000b

9.3.108 SECONDARY PCI EXPRESS EXTENDED CAPABILITY HEADER – OFFSET 210h

BIT	FUNCTION	TYPE	DESCRIPTION	EEPROM/ I2C-SMBUS	DEFAULT
15:0	PCI Express Extended Capability ID	RO	Read as 0019h to indicate that this is PCI Express Extended Capability register for Secondary PCI Express.	No	0019h
19:16	Capability Version	RO	Must be 1h for this version.	No	1h
31:20	Next Capability ID	RO	Point to next PCI extended capability structure.	Yes	2B0h for Up 2A0h for Down

9.3.109 LINK CONTROL 3 REGISTER – OFFSET 214h

BIT	FUNCTION	TYPE	DESCRIPTION	EEPROM/ I2C-SMBUS	DEFAULT
0	Perform Equalization	RW	When this bit is 1b and a 1b is written to the Retrain Link bit with the Target Link Speed field set to 8.0 GT/s, the downstream port must perform Link Equalization.	Yes	0
1	Link Equalization Request Interrupt Enable	RW	When set, this bit enables the generation of an interrupt to indicate that the Link Equalization bit has been set.	Yes	0
31:2	Reserved	RsvdP	Not support.	No	0000h

9.3.110 LANE ERROR STATUS REGISTER – OFFSET 218h

BIT	FUNCTION	TYPE	DESCRIPTION	EEPROM/ I2C-SMBUS	DEFAULT
31:0	Lane Error Status	RW1C	Each bit indicates if the corresponding Lane detected a Lane-base error.	Yes	0000_0000h

9.3.111 LANE EQUALIZATION CONTROL REGISTER – OFFSET 21Ch – 230h

Table 9-2 Lane Equalization Control Register Locations

CFG_OFFSET	Lane Number	CFG_OFFSET	Lane Number
21Ch	0	22Ch	8
21Eh	1	22Eh	9
220h	2	230h	10
222h	3	232h	11
224h	4	234h	12
226h	5	236h	13
228h	6	238h	14
22Ah	7	23Ah	15

Table 9-3 Lane Equalization Control Register Definitions

BIT	FUNCTION	TYPE	DESCRIPTION	EEPROM/ I2C-SMBUS	DEFAULT
3:0	Downstream Port Transmitter Preset	RW	Transmitter Preset used for equalization by this Port when the Port is operating as a Downstream Port. This field is ignored when the Port is operating as an Upstream Port.	Yes	0h for Up 8h for Down
7:4	Downstream Port Receiver Preset Hint	RW	Receiver Preset Hint may be used as a hint for receiver equalization by this Port when the Port is operating as a Downstream Port. This field is ignored when the Port is operating as an Upstream Port.	Yes	0h for Up 2h for Down
11:8	Upstream Port Transmitter Preset	RO	For downstream ports, Field contains the Transmit Preset value sent or received during Link Equalization. For upstream port, it is debugged used only.	Yes	0h for Up 8h for Down
14:12	Upstream Port Receiver Preset Hint	RO	For downstream ports, Field contains the Receiver Preset Hint value sent or received during Link Equalization. For upstream port, it is debugged used only.	Yes	0h for Up 2h for Down

BIT	FUNCTION	TYPE	DESCRIPTION	EEPROM/ I2C-SMBUS	DEFAULT
15	Reserved	RsvdP	Not support.	No	0

9.3.112 DPC EXTENDED CAPABILITY HEADER – OFFSET 2A0h (Downstream Port Only)

BIT	FUNCTION	TYPE	DESCRIPTION	EEPROM/ I2C-SMBUS	DEFAULT
15:0	PCI Express Extended Capability ID	RO	Read as 001Dh to indicate that this is PCI Express Extended Capability register for DPC.	No	001Dh
19:16	Capability Version	RO	Must be 1h for this version.	No	1h
31:20	Next Capability ID	RO	Point to next PCI extended capability structure.	Yes	2B0h

9.3.113 DPC CAPABILITY REGISTER – OFFSET 2A4h (Downstream Port Only)

BIT	FUNCTION	TYPE	DESCRIPTION	EEPROM/ I2C-SMBUS	DEFAULT
4:0	DPC Interrupt Message Number	RO	This field indicates which MSI/MSI-X vector is used for the interrupt message generated in association with the DPC Capability structure.	No	01h
15:5	Reserved	RsvdP	Not support.	No	0-0h

9.3.114 DPC CONTROL REGISTER – OFFSET 2A4h (Downstream Port Only)

BIT	FUNCTION	TYPE	DESCRIPTION	EEPROM/ I2C-SMBUS	DEFAULT
17:16	DPC Trigger Enable	RW	This field enables DPC and controls the conditions that cause DPC to be triggered. 00b... DPC is disabled 01b... DPC is enabled and is triggered when the Downstream port detects and unmasked uncorrectable error or when the Downstream port receives an ERR_FATAL message. 10b... DPC is enabled and is triggered when the Downstream port detects an unmasked uncorrectable error or when the Downstream port receives an ERR_NONFATAL or ERR_FATAL message 11b... Reserved	Yes	00b
18	DPC Completion Control	RW	This bit controls the Completion Status for Completions formed during DPC. 0b: Completer Abort (CA) Completion Status 1b: Unsupported Request (UR) Completion Status	Yes	0
19	DPC Interrupt Enable	RW	When set, this bit enables the generation of an interrupt to indicate that DPC has been triggered.	Yes	0
20	DPC ERR_COR Enable	RW	When set, this bit enables the sending of an ERR_COR message to indicate that DPC has been triggered.	Yes	0
31:21	Reserved	RsvdP	Not support.	No	0-0h

9.3.115 DPC STATUS REGISTER – OFFSET 2A8h (Downstream Port Only)

BIT	FUNCTION	TYPE	DESCRIPTION	EEPROM/ I2C-SMBUS	DEFAULT
0	DPC Trigger Status	RW1C	When set, this bit indicates that DPC has been triggered.	Yes	0
2:1	DPC Trigger Reason	RW1C	This field indicates why DPC has been triggered. 00b... DPC was triggered due to an unmasked uncorrectable error 01b... DPC was triggered due to receiving an ERR_NONFATAL 10b... DPC was triggered due to receiving an ERR_FATAL 11b... Reserved	Yes	00b

BIT	FUNCTION	TYPE	DESCRIPTION	EEPROM/ I2C-SMBUS	DEFAULT
3	DPC Interrupt Status	RW1C	This bit is set if DPC is triggered while the DPC interrupt Enable bit is set.	Yes	0
15:4	Reserved	RsvdP	Not support.	No	0-0h

9.3.116 DPC ERROR SOURCE ID REGISTER – OFFSET 2A8h (Downstream Port Only)

BIT	FUNCTION	TYPE	DESCRIPTION	EEPROM/ I2C-SMBUS	DEFAULT
31:16	DPC Error Source ID	RO	When the DPC Trigger Reason field indicates that DPC was triggered due to the reception of an ERR_NONFATAL or ERR_FATAL, this register contains the Requester ID of the received message. Otherwise, the value of this register is undefined.	No	0000h

9.3.117 LI PM SUBSTATES ENHANCED CAPABILITY HEADER – OFFSET 2B0h

BIT	FUNCTION	TYPE	DESCRIPTION	EEPROM/ I2C-SMBUS	DEFAULT
15:0	PCI Express Extended Capability ID	RO	Read as 001Eh to indicate that this is PCI Express Extended Capability register for L1 PM Substates.	No	001Eh
19:16	Capability Version	RO	Must be 1h for this version.	No	1h
31:20	Next Capability ID	RO	Point to next PCI extended capability structure.	Yes	300h

9.3.118 L1 PM SUBSTATES CAPABILITY REGISTER – OFFSET 2B4h

BIT	FUNCTION	TYPE	DESCRIPTION	EEPROM/ I2C-SMBUS	DEFAULT
0	PCI-PM L1.2 Supported	RO	When set this bit indicates that PCI-PM L1.2 is supported.	Yes	0
1	PCI-PM L1.1 Supported	RO	When set this bit indicates that PCI-PM L1.1 is supported and must be set by all ports implementing L1 PM Substates.	Yes	0
2	ASPM L1.2 Supported	RO	When set this bit indicates that ASPM L1.2 is supported.	Yes	0
3	ASPM L1.1 Supported	RO	When set this bit indicates that ASPM L1.1 is supported.	Yes	0
4	L1 PM Substates Supported	RO	When set this bit indicates that this port supports L1 PM Substates.	Yes	1
31:5	Reserved	RsvdP	Not support.	No	0-0h

9.3.119 L1 PM SUBSTATES CONTROL 1 REGISTER – OFFSET 2B8h

BIT	FUNCTION	TYPE	DESCRIPTION	EEPROM/ I2C-SMBUS	DEFAULT
0	PCI-PM L1.2 Enable	RW	When set this bit enables PCI-PM L1.2. Required for both upstream and downstream ports.	Yes	0
1	PCI-PM L1.1 Enable	RW	When set this bit enables PCI-PM L1.1. Required for both upstream and downstream ports.	Yes	0
2	ASPM L1.2 Enable	RW	When set this bit enables ASPM L1.2. Required for both upstream and downstream ports.	Yes	0
3	ASPM L1.1 Enable	RW	When set this bit enables ASPM L1.1. Required for both upstream and downstream ports.	Yes	0
31:4	Reserved	RsvdP	Not support.	No	0-0h

9.3.120 L1 PM SUBSTATES CONTROL 2 REGISTER – OFFSET 2BCh

BIT	FUNCTION	TYPE	DESCRIPTION	EEPROM/ I2C-SMBUS	DEFAULT
31:0	Reserved	RsvdP	Not support.	No	0000_0000h

9.3.121 VENDOR-SPECIFIC ENHANCED CAPABILITY HEADER – OFFSET 300h

BIT	FUNCTION	TYPE	DESCRIPTION	EEPROM/ I2C-SMBUS	DEFAULT
15:0	PCI Express Extended Capability ID	RO	Read as 000Bh to indicate that this is PCI Express Extended Capability register for Vendor-Specific.	No	000Bh
19:16	Capability Version	RO	Must be 1h for this version.	No	1h
31:20	Next Capability ID	RO	Points to 000h.	No	000h

9.3.122 VENDOR-SPECIFIC HEADER – OFFSET 304h

BIT	FUNCTION	TYPE	DESCRIPTION	EEPROM/ I2C-SMBUS	DEFAULT
15:0	VSEC ID	RO	This field is a vendor-defined ID number that indicates the nature and format of the VSEC structure.	Yes	0000h
19:16	VSEC Rev	RO	This field is a vendor-defined version number that indicates the version of the VSEC structure.	No	0h
31:20	VSEC Length	RO	This field indicates the number of bytes in the entire VSEC structure.	Yes	560h

9.3.123 EEPROM CONTROL REGISTER – OFFSET 308h (Upstream Port Only)

BIT	FUNCTION	TYPE	DESCRIPTION	EEPROM/ I2C-SMBUS	DEFAULT
0	EEPROM Start	RW	Starts the EEPROM read or write cycle. This bit will auto Clear to 0 when access is completed. 1b: start read or write cycle	Yes	0
3:1	Reserved	RsvdP	Not support.	No	000b
4	EEPROM Autoload Status	RO	0b: EEPROM autoload is unsuccessful or is disabled 1b: EEPROM autoload is successful after PERST_L.	No	0
5	EEPROM is in programming mode	RO	0b: EEPROM is in auto-load mode 1b: EEPROM is in programming mode	Yes	1
7:6	EEPROM Clock Rate	RW	Determines the frequency of the EEPROM clock which is derived from the primary clock. 00b: 500MHz/128 01b: 500MHz/(128*2) 10b: 500MHz/(128*4) 11b: 500MHz/(128*8)	Yes	00b
15:8	EEPROM Status	RO	Indicates the EEPROM status reflected by EEPROM read command.	No	00h
23:16	EEPROM Command	RW	01h: write STATUS register 02h: EEPROM write 03h: EEPROM read 04h: disable write operation 05h: read STATUS register 06h: enable write operation C7h: erase entire EEPROM	Yes	00h
30:24	Reserved	RsvdP	Not support.	No	00h
31	Size 64K Mode	RW	0b: EEPROM size is less or equal to 64K 1b: EEPROM size is larger 64K	Yes	0

9.3.124 EEPROM ADDRESS AND DATA REGISTER – OFFSET 30Ch (Upstream Port Only)

BIT	FUNCTION	TYPE	DESCRIPTION	EEPROM/ I2C-SMBUS	DEFAULT
15:0	EEPROM Address	RW	Contains the EEPROM address.	Yes	0000h
31:16	EEPROM Data	RW	Contains the EEPROM data.	Yes	0000h

9.3.125 DEBUGOUT CONTROL REGISTER – OFFSET 310h (Port 0 Only)

BIT	FUNCTION	TYPE	DESCRIPTION	EEPROM/ I2C-SMBUS	DEFAULT
4:0	Debug Mode Select	RW	Debug mode select. Selects a signal group for probing the current internal status. For example, “0” represents LTSSM signal group. As to other values, please inquire internal team for further information.	Yes	0_0000b
7:5	Debug Port_Select_S1	RW	Debug port select s1. Selects a port number for monitoring at a given signal group.	Yes	000b
8	DebugPort_Select_S2	RW	Debugport select s2.	Yes	0
9	Debug Output Start	RW	Start to capture debug output data.	Yes	0
31:10	Reserved	RsvdP	Not support.	No	0-0h

9.3.126 DEBUGOUT DATA REGISTER – OFFSET 314h (Port 0 Only)

BIT	FUNCTION	TYPE	DESCRIPTION	EEPROM/ I2C-SMBUS	DEFAULT
9:0	Debug Output Data	RO	Content of the debug output data. For example, if LTSSM signal group is selected, the meaning of debug output data is as follows. 001h: detect 002h: polling 004h: configuration 008h: L0 010h: L1 020h: L2 040h: disable 080h: hot-reset 100h: loopback 200h: recovery Others: Reserved	No	000h
31:10	Reserved	RsvdP	Not support	No	0000_0h

9.3.127 SMBUS CONTROL AND STATUS REGISTER – OFFSET 318h (Port 0 Only)

BIT	FUNCTION	TYPE	DESCRIPTION	EEPROM/ I2C-SMBUS	DEFAULT
0	SMBus Enabled	RW	0b: SMBus is disabled while I2C is enabled 1b: SMBus is enabled while I2C is disabled	Yes	Set by SMBUS_EN_L
3:1	I2C/SMBUS Address [2:0]	RW	Used to set I2C/SMBUS Address[2:0].	Yes	Set by I2C_ADDRESS [2:0]
7:4	I2C/SMBUS Address [6:3]	RW	Used to set I2C/SMBUS Address[6:3].	Yes	1101b
8	ARP_Disable	RW	Test used only.	Yes	1
9	PEC Check Disable	RW	0b: enable PEC check 1b: disable PEC check	Yes	1
10	AV Flag	RW	Test used only.	Yes	0
11	AR Flag	RW	Test used only.	Yes	0
13:12	UDID Addr Type	RW	Test used only.	Yes	00b
14	UDID PEC Support	RW	Test used only.	Yes	1
15	Cross Strapping Done	RO	Test used only.	No	0
23:16	UDID Vendor ID	RW	Test used only.	Yes	B0h
26:24	UDID Revision ID	RW	Test used only.	Yes	001b
27	Fty Test 0	RW	Test used only.	Yes	0
28	SMBUS In Progress	RO	0b: SMBUS interface is idle 1b: SMBUS interface is busy	No	0
29	PEC Check Fail	RO	0b: PEC check successfully 1b: PEC check failed	No	0

BIT	FUNCTION	TYPE	DESCRIPTION	EEPROM/ I2C-SMBUS	DEFAULT
30	Unsupported SMBUS Command	RO	0b: supported command 1b: unsupported command	No	0
31	Reserved	RO	Not support.	No	1

9.3.128 GPIO 0-15 DIRECTION CONTROL REGISTER – OFFSET 31Ch (Port 0 Only)

BIT	FUNCTION	TYPE	DESCRIPTION	EEPROM/ I2C-SMBUS	DEFAULT
0	GPIO[0] Source/Destination	RW	As Input: 0b: Input Data Register (offset 328h[0]) 1b: General Interrupt (INTx, or MSI) As Output: 0b: From GPIO[0] Output Data register (offset 330h[0]) 1b: Reserved	Yes	0
1	GPIO[0] Direction Control	RW	0b: Input 1b: Output	Yes	0
2	GPIO[1] Source/Destination	RW	As Input: 0b: Input Data Register (offset 328h[1]) 1b: General Interrupt (INTx, or MSI) As Output: 0b: From GPIO[1] Output Data register (offset 330h[1]) 1b: Reserved	Yes	0
3	GPIO[1] Direction Control	RW	0b: Input 1b: Output	Yes	0
4	GPIO[2] Source/Destination	RW	As Input: 0b: Input Data Register (offset 328h[2]) 1b: General Interrupt (INTx, or MSI) As Output: 0b: From GPIO[2] Output Data register (offset 330h[2]) 1b: Reserved	Yes	0
5	GPIO[2] Direction Control	RW	0b: Input 1b: Output	Yes	0
6	GPIO[3] Source/Destination	RW	As Input: 0b: Input Data Register (offset 328h[3]) 1b: General Interrupt (INTx, or MSI) As Output: 0b: From GPIO[3] Output Data register (offset 330h[3]) 1b: Reserved	Yes	0
7	GPIO[3] Direction Control	RW	0b: Input 1b: Output	Yes	0
8	GPIO[4] Source/Destination	RW	As Input: 0b: Input Data Register (offset 328h[4]) 1b: General Interrupt (INTx, or MSI) As Output: 0b: From GPIO[4] Output Data register (offset 330h[4]) 1b: Reserved	Yes	0
9	GPIO[4] Direction Control	RW	0b: Input 1b: Output	Yes	0
10	GPIO[5] Source/Destination	RW	As Input: 0b: Input Data Register (offset 328h[5]) 1b: General Interrupt (INTx, or MSI) As Output: 0b: From GPIO[5] Output Data register (offset 330h[5]) 1b: Reserved	Yes	0
11	GPIO[5] Direction Control	RW	0b: Input 1b: Output	Yes	0
12	GPIO[6] Source/Destination	RW	As Input: 0b: Input Data Register (offset 328h[6]) 1b: General Interrupt (INTx, or MSI) As Output: 0b: From GPIO[6] Output Data register (offset 330h[6]) 1b: Reserved	Yes	0
13	GPIO[6] Direction Control	RW	0b: Input 1b: Output	Yes	0

BIT	FUNCTION	TYPE	DESCRIPTION	EEPROM/ I2C-SMBUS	DEFAULT
14	GPIO[7] Source/Destination	RW	As Input: 0b: Input Data Register (offset 328h[7]) 1b: General Interrupt (INTx, or MSI) As Output: 0b: From GPIO[7] Output Data register (offset 330h[7]) 1b: Reserved	Yes	0
15	GPIO[7] Direction Control	RW	0b: Input 1b: Output	Yes	0
16	GPIO[8] Source/Destination	RW	As Input: 0b: Input Data Register (offset 328h[8]) 1b: General Interrupt (INTx, or MSI) As Output: 0b: From GPIO[8] Output Data register (offset 330h[8]) 1b: Reserved	Yes	0
17	GPIO[8] Direction Control	RW	0b: Input 1b: Output	Yes	0
18	GPIO[9] Source/Destination	RW	As Input: 0b: Input Data Register (offset 328h[9]) 1b: General Interrupt (INTx, or MSI) As Output: 0b: From GPIO[9] Output Data register (offset 330h[9]) 1b: Reserved	Yes	0
19	GPIO[9] Direction Control	RW	0b: Input 1b: Output	Yes	0
20	GPIO[10] Source/Destination	RW	As Input: 0b: Input Data Register (offset 328h[10]) 1b: General Interrupt (INTx, or MSI) As Output: 0b: From GPIO[10] Output Data register (offset 330h[10]) 1b: Reserved	Yes	0
21	GPIO[10] Direction Control	RW	0b: Input 1b: Output	Yes	0
22	GPIO[11] Source/Destination	RW	As Input: 0b: Input Data Register (offset 328h[11]) 1b: General Interrupt (INTx, or MSI) As Output: 0b: From GPIO[11] Output Data register (offset 330h[11]) 1b: Reserved	Yes	0
23	GPIO[11] Direction Control	RW	0b: Input 1b: Output	Yes	0
24	GPIO[12] Source/Destination	RW	As Input: 0b: Input Data Register (offset 328h[12]) 1b: General Interrupt (INTx, or MSI) As Output: 0b: From GPIO[12] Output Data register (offset 330h[12]) 1b: Reserved	Yes	0
25	GPIO[12] Direction Control	RW	0b: Input 1b: Output	Yes	0
26	GPIO[13] Source/Destination	RW	As Input: 0b: Input Data Register (offset 328h[13]) 1b: General Interrupt (INTx, or MSI) As Output: 0b: From GPIO[13] Output Data register (offset 330h[13]) 1b: Reserved	Yes	0
27	GPIO[13] Direction Control	RW	0b: Input 1b: Output	Yes	0
28	GPIO[14] Source/Destination	RW	As Input: 0b: Input Data Register (offset 328h[14]) 1b: General Interrupt (INTx, or MSI) As Output: 0b: From GPIO[14] Output Data register (offset 330h[14]) 1b: Reserved	Yes	0
29	GPIO[14] Direction Control	RW	0b: Input 1b: Output	Yes	0

BIT	FUNCTION	TYPE	DESCRIPTION	EEPROM/ I2C-SMBUS	DEFAULT
30	GPIO[15] Source/Destination	RW	As Input: 0b: Input Data Register (offset 328h[15]) 1b: General Interrupt (INTx, or MSI) As Output: 0b: From GPIO[15] Output Data register (offset 330h[15]) 1b: Reserved	Yes	0
31	GPIO[15] Direction Control	RW	0b: Input 1b: Output	Yes	0

9.3.129 GPIO 16-31 DIRECTION CONTROL REGISTER – OFFSET 320h (Port 0 Only)

BIT	FUNCTION	TYPE	DESCRIPTION	EEPROM/ I2C-SMBUS	DEFAULT
0	GPIO[16] Source/Destination	RW	As Input: 0b: Input Data Register (offset 32Ch[0]) 1b: General Interrupt (INTx, or MSI) As Output: 0b: From GPIO[16] Output Data register (offset 334h[0]) 1b: Reserved	Yes	0
1	GPIO[16] Direction Control	RW	0b: Input 1b: Output	Yes	0
2	GPIO[17] Source/Destination	RW	As Input: 0b: Input Data Register (offset 32Ch[1]) 1b: General Interrupt (INTx, or MSI) As Output: 0b: From GPIO[17] Output Data register (offset 334h[1]) 1b: Reserved	Yes	0
3	GPIO[17] Direction Control	RW	0b: Input 1b: Output	Yes	0
4	GPIO[18] Source/Destination	RW	As Input: 0b: Input Data Register (offset 32Ch[2]) 1b: General Interrupt (INTx, or MSI) As Output: 0b: From GPIO[18] Output Data register (offset 334h[2]) 1b: Reserved	Yes	0
5	GPIO[18] Direction Control	RW	0b: Input 1b: Output	Yes	0
6	GPIO[19] Source/Destination	RW	As Input: 0b: Input Data Register (offset 32Ch[3]) 1b: General Interrupt (INTx, or MSI) As Output: 0b: From GPIO[19] Output Data register (offset 334h[3]) 1b: Reserved	Yes	0
7	GPIO[19] Direction Control	RW	0b: Input 1b: Output	Yes	0
8	GPIO[20] Source/Destination	RW	As Input: 0b: Input Data Register (offset 32Ch[4]) 1b: General Interrupt (INTx, or MSI) As Output: 0b: From GPIO[20] Output Data register (offset 334h[4]) 1b: Reserved	Yes	0
9	GPIO[20] Direction Control	RW	0b: Input 1b: Output	Yes	0
10	GPIO[21] Source/Destination	RW	As Input: 0b: Input Data Register (offset 32Ch[5]) 1b: General Interrupt (INTx, or MSI) As Output: 0b: From GPIO[21] Output Data register (offset 334h[5]) 1b: Reserved	Yes	0
11	GPIO[21] Direction Control	RW	0b: Input 1b: Output	Yes	0

BIT	FUNCTION	TYPE	DESCRIPTION	EEPROM/ I2C-SMBUS	DEFAULT
12	GPIO[22] Source/Destination	RW	As Input: 0b: Input Data Register (offset 32Ch[6]) 1b: General Interrupt (INTx, or MSI) As Output: 0b: From GPIO[22] Output Data register (offset 334h[6]) 1b: Reserved	Yes	0
13	GPIO[22] Direction Control	RW	0b: Input 1b: Output	Yes	0
14	GPIO[23] Source/Destination	RW	As Input: 0b: Input Data Register (offset 32Ch[7]) 1b: General Interrupt (INTx, or MSI) As Output: 0b: From GPIO[23] Output Data register (offset 334h[7]) 1b: Reserved	Yes	0
15	GPIO[23] Direction Control	RW	0b: Input 1b: Output	Yes	0
16	GPIO[24] Source/Destination	RW	As Input: 0b: Input Data Register (offset 32Ch[8]) 1b: General Interrupt (INTx, or MSI) As Output: 0b: From GPIO[24] Output Data register (offset 334h[8]) 1b: Reserved	Yes	0
17	GPIO[24] Direction Control	RW	0b: Input 1b: Output	Yes	0
18	GPIO[25] Source/Destination	RW	As Input: 0b: Input Data Register (offset 32Ch[9]) 1b: General Interrupt (INTx, or MSI) As Output: 0b: From GPIO[25] Output Data register (offset 334h[9]) 1b: Reserved	Yes	0
19	GPIO[25] Direction Control	RW	0b: Input 1b: Output	Yes	0
20	GPIO[26] Source/Destination	RW	As Input: 0b: Input Data Register (offset 32Ch[10]) 1b: General Interrupt (INTx, or MSI) As Output: 0b: From GPIO[26] Output Data register (offset 334h[10]) 1b: Reserved	Yes	0
21	GPIO[26] Direction Control	RW	0b: Input 1b: Output	Yes	0
22	GPIO[27] Source/Destination	RW	As Input: 0b: Input Data Register (offset 32Ch[11]) 1b: General Interrupt (INTx, or MSI) As Output: 0b: From GPIO[27] Output Data register (offset 334h[11]) 1b: Reserved	Yes	0
23	GPIO[27] Direction Control	RW	0b: Input 1b: Output	Yes	0
24	GPIO[28] Source/Destination	RW	As Input: 0b: Input Data Register (offset 32Ch[12]) 1b: General Interrupt (INTx, or MSI) As Output: 0b: From GPIO[28] Output Data register (offset 334h[12]) 1b: Reserved	Yes	0
25	GPIO[28] Direction Control	RW	0b: Input 1b: Output	Yes	0
26	GPIO[29] Source/Destination	RW	As Input: 0b: Input Data Register (offset 32Ch[13]) 1b: General Interrupt (INTx, or MSI) As Output: 0b: From GPIO[29] Output Data register (offset 334h[13]) 1b: Reserved	Yes	0
27	GPIO[29] Direction Control	RW	0b: Input 1b: Output	Yes	0

BIT	FUNCTION	TYPE	DESCRIPTION	EEPROM/ I2C-SMBUS	DEFAULT
28	GPIO[30] Source/Destination	RW	As Input: 0b: Input Data Register (offset 32Ch[14]) 1b: General Interrupt (INTx, or MSI) As Output: 0b: From GPIO[30] Output Data register (offset 334h[14]) 1b: Reserved	Yes	0
29	GPIO[30] Direction Control	RW	0b: Input 1b: Output	Yes	0
30	GPIO[31] Source/Destination	RW	As Input: 0b: Input Data Register (offset 32Ch[15]) 1b: General Interrupt (INTx, or MSI) As Output: 0b: From GPIO[31] Output Data register (offset 334h[15]) 1b: Reserved	Yes	0
31	GPIO[31] Direction Control	RW	0b: Input 1b: Output	Yes	0

9.3.130 GPIO INPUT DE-BOUNCE REGISTER – OFFSET 324h (Port 0 Only)

BIT	FUNCTION	TYPE	DESCRIPTION	EEPROM/ I2C-SMBUS	DEFAULT
31:0	GPIOx Input De- Bounce Control	RW	Controls de-bounce when the corresponding GPIOx signal is configured as an input. Bit[31:0] correspond to GPIO[31:0], respectively. 0b: GPIOx input is not de-bounced 1b: GPIOx input is de-bounced	Yes	0000_0000h

9.3.131 GPIO 0-15 INPUT DATA REGISTER – OFFSET 328h (Port 0 Only)

BIT	FUNCTION	TYPE	DESCRIPTION	EEPROM/ I2C-SMBUS	DEFAULT
0	GPIO[0] Input Data	RO	GPIO[0] Input Data Return 0 if GPIO[0] is configured as an output (offset 31Ch[1]=1) Return the state of GPIO[0] pin if GPIO[0] is configured as an input (offset 31Ch[1]=0)	No	Set by GPIO[0]
1	GPIO[1] Input Data	RO	GPIO[1] Input Data Return 0 if GPIO[1] is configured as an output (offset 31Ch[3]=1) Return the state of GPIO[1] pin if GPIO[1] is configured as an input (offset 31Ch[3]=0)	No	Set by GPIO[1]
2	GPIO[2] Input Data	RO	GPIO[2] Input Data Return 0 if GPIO[2] is configured as an output (offset 31Ch[5]=1) Return the state of GPIO[2] pin if GPIO[2] is configured as an input (offset 31Ch[5]=0)	No	Set by GPIO[2]
3	GPIO[3] Input Data	RO	GPIO[3] Input Data Return 0 if GPIO[3] is configured as an output (offset 31Ch[7]=1) Return the state of GPIO[3] pin if GPIO[3] is configured as an input (offset 31Ch[7]=0)	No	Set by GPIO[3]
4	GPIO[4] Input Data	RO	GPIO[4] Input Data Return 0 if GPIO[4] is configured as an output (offset 31Ch[9]=1) Return the state of GPIO[4] pin if GPIO[4] is configured as an input (offset 31Ch[9]=0)	No	Set by GPIO[4]
5	GPIO[5] Input Data	RO	GPIO[5] Input Data Return 0 if GPIO[5] is configured as an output (offset 31Ch[11]=1) Return the state of GPIO[5] pin if GPIO[5] is configured as an input (offset 31Ch[11]=0)	No	Set by GPIO[5]
6	GPIO[6] Input Data	RO	GPIO[6] Input Data Return 0 if GPIO[6] is configured as an output (offset 31Ch[13]=1) Return the state of GPIO[6] pin if GPIO[6] is configured as an input (offset 31Ch[13]=0)	No	Set by GPIO[6]
7	GPIO[7] Input Data	RO	GPIO[7] Input Data Return 0 if GPIO[7] is configured as an output (offset 31Ch[15]=1) Return the state of GPIO[7] pin if GPIO[7] is configured as an input (offset 31Ch[15]=0)	No	Set by GPIO[7]

BIT	FUNCTION	TYPE	DESCRIPTION	EEPROM/ I2C-SMBUS	DEFAULT
8	GPIO[8] Input Data	RO	GPIO[8] Input Data Return 0 if GPIO[8] is configured as an output (offset 31Ch[17]=1) Return the state of GPIO[8] pin if GPIO[8] is configured as an input (offset 31Ch[17]=0)	No	Set by GPIO[8]
9	GPIO[9] Input Data	RO	GPIO[9] Input Data Return 0 if GPIO[9] is configured as an output (offset 31Ch[19]=1) Return the state of GPIO[9] pin if GPIO[9] is configured as an input (offset 31Ch[19]=0)	No	Set by GPIO[9]
10	GPIO[10] Input Data	RO	GPIO[10] Input Data Return 0 if GPIO[10] is configured as an output (offset 31Ch[21]=1) Return the state of GPIO[10] pin if GPIO[10] is configured as an input (offset 31Ch[21]=0)	No	Set by GPIO[10]
11	GPIO[11] Input Data	RO	GPIO[11] Input Data Return 0 if GPIO[11] is configured as an output (offset 31Ch[23]=1) Return the state of GPIO[11] pin if GPIO[11] is configured as an input (offset 31Ch[23]=0)	No	Set by GPIO[11]
12	GPIO[12] Input Data	RO	GPIO[12] Input Data Return 0 if GPIO[12] is configured as an output (offset 31Ch[25]=1) Return the state of GPIO[12] pin if GPIO[12] is configured as an input (offset 31Ch[25]=0)	No	Set by GPIO[12]
13	GPIO[13] Input Data	RO	GPIO[13] Input Data Return 0 if GPIO[13] is configured as an output (offset 31Ch[27]=1) Return the state of GPIO[13] pin if GPIO[13] is configured as an input (offset 31Ch[27]=0)	No	Set by GPIO[13]
14	GPIO[14] Input Data	RO	GPIO[14] Input Data Return 0 if GPIO[14] is configured as an output (offset 31Ch[29]=1) Return the state of GPIO[14] pin if GPIO[14] is configured as an input (offset 31Ch[29]=0)	No	Set by GPIO[14]
15	GPIO[15] Input Data	RO	GPIO[15] Input Data Return 0 if GPIO[15] is configured as an output (offset 31Ch[31]=1) Return the state of GPIO[15] pin if GPIO[15] is configured as an input (offset 31Ch[31]=0)	No	Set by GPIO[15]
31:16	Reserved	RsvdP	Not support.	No	0000h

9.3.132 GPIO 16-31 INPUT DATA REGISTER – OFFSET 32Ch (Port 0 Only)

BIT	FUNCTION	TYPE	DESCRIPTION	EEPROM/ I2C-SMBUS	DEFAULT
0	GPIO[16] Input Data	RO	GPIO[16] Input Data Return 0 if GPIO[16] is configured as an output (offset 320h[1]=1) Return the state of GPIO[16] pin if GPIO[16] is configured as an input (offset 320h[1]=0)	Yes	Set by GPIO[16]
1	GPIO[17] Input Data	RO	GPIO[17] Input Data Return 0 if GPIO[17] is configured as an output (offset 320h[3]=1) Return the state of GPIO[17] pin if GPIO[17] is configured as an input (offset 320h[3]=0)	Yes	Set by GPIO[17]
2	GPIO[18] Input Data	RO	GPIO[18] Input Data Return 0 if GPIO[18] is configured as an output (offset 320h[5]=1) Return the state of GPIO[18] pin if GPIO[18] is configured as an input (offset 320h[5]=0)	Yes	Set by GPIO[18]
3	GPIO[19] Input Data	RO	GPIO[19] Input Data Return 0 if GPIO[19] is configured as an output (offset 320h[7]=1) Return the state of GPIO[19] pin if GPIO[19] is configured as an input (offset 320h[7]=0)	Yes	Set by GPIO[19]
4	GPIO[20] Input Data	RO	GPIO[20] Input Data Return 0 if GPIO[20] is configured as an output (offset 320h[9]=1) Return the state of GPIO[20] pin if GPIO[20] is configured as an input (offset 320h[9]=0)	Yes	Set by GPIO[20]

BIT	FUNCTION	TYPE	DESCRIPTION	EEPROM/ I2C-SMBUS	DEFAULT
5	GPIO[21] Input Data	RO	GPIO[21] Input Data Return 0 if GPIO[21] is configured as an output (offset 320h[11]=1) Return the state of GPIO[21] pin if GPIO[21] is configured as an input (offset 320h[11]=0)	Yes	Set by GPIO[21]
6	GPIO[22] Input Data	RO	GPIO[22] Input Data Return 0 if GPIO[22] is configured as an output (offset 320h[13]=1) Return the state of GPIO[22] pin if GPIO[22] is configured as an input (offset 320h[13]=0)	Yes	Set by GPIO[22]
7	GPIO[23] Input Data	RO	GPIO[23] Input Data Return 0 if GPIO[23] is configured as an output (offset 320h[15]=1) Return the state of GPIO[23] pin if GPIO[23] is configured as an input (offset 320h[15]=0)	Yes	Set by GPIO[23]
8	GPIO[24] Input Data	RO	GPIO[24] Input Data Return 0 if GPIO[24] is configured as an output (offset 320h[17]=1) Return the state of GPIO[24] pin if GPIO[24] is configured as an input (offset 320h[17]=0)	Yes	Set by GPIO[24]
9	GPIO[25] Input Data	RO	GPIO[25] Input Data Return 0 if GPIO[25] is configured as an output (offset 320h[19]=1) Return the state of GPIO[25] pin if GPIO[25] is configured as an input (offset 320h[19]=0)	Yes	Set by GPIO[25]
10	GPIO[26] Input Data	RO	GPIO[26] Input Data Return 0 if GPIO[26] is configured as an output (offset 320h[21]=1) Return the state of GPIO[26] pin if GPIO[26] is configured as an input (offset 320h[21]=0)	Yes	Set by GPIO[26]
11	GPIO[27] Input Data	RO	GPIO[27] Input Data Return 0 if GPIO[27] is configured as an output (offset 320h[23]=1) Return the state of GPIO[27] pin if GPIO[27] is configured as an input (offset 320h[23]=0)	Yes	Set by GPIO[27]
12	GPIO[28] Input Data	RO	GPIO[28] Input Data Return 0 if GPIO[28] is configured as an output (offset 320h[25]=1) Return the state of GPIO[28] pin if GPIO[28] is configured as an input (offset 320h[25]=0)	Yes	Set by GPIO[28]
13	GPIO[29] Input Data	RO	GPIO[29] Input Data Return 0 if GPIO[29] is configured as an output (offset 320h[27]=1) Return the state of GPIO[29] pin if GPIO[29] is configured as an input (offset 320h[27]=0)	Yes	Set by GPIO[29]
14	GPIO[30] Input Data	RO	GPIO[30] Input Data Return 0 if GPIO[30] is configured as an output (offset 320h[29]=1) Return the state of GPIO[30] pin if GPIO[30] is configured as an input (offset 320h[29]=0)	Yes	Set by GPIO[30]
15	GPIO[31] Input Data	RO	GPIO[31] Input Data Return 0 if GPIO[31] is configured as an output (offset 320h[31]=1) Return the state of GPIO[31] pin if GPIO[31] is configured as an input (offset 320h[31]=0)	Yes	Set by GPIO[31]
31:16	Reserved	RsvdP	Not support.	Yes	0000h

9.3.133 GPIO 0-15 OUTPUT DATA REGISTER – OFFSET 330h (Port 0 Only)

BIT	FUNCTION	TYPE	DESCRIPTION	EEPROM/ I2C-SMBUS	DEFAULT
0	GPIO[0] Output Data	RW	GPIO[0] Output Data The value written to this bit is driven to GPIO[0] output if GPIO[0] is configured as an output (offset 31Ch[1]=1)	Yes	0
1	GPIO[1] Output Data	RW	GPIO[1] Output Data The value written to this bit is driven to GPIO[1] output if GPIO[1] is configured as an output (offset 31Ch[3]=1)	Yes	0
2	GPIO[2] Output Data	RW	GPIO[2] Output Data The value written to this bit is driven to GPIO[2] output if GPIO[2] is configured as an output (offset 31Ch[5]=1)	Yes	0
3	GPIO[3] Output Data	RW	GPIO[3] Output Data The value written to this bit is driven to GPIO[3] output if GPIO[3] is configured as an output (offset 31Ch[7]=1)	Yes	0
4	GPIO[4] Output Data	RW	GPIO[4] Output Data The value written to this bit is driven to GPIO[4] output if GPIO[4] is configured as an output (offset 31Ch[9]=1)	Yes	0

BIT	FUNCTION	TYPE	DESCRIPTION	EEPROM/ I2C-SMBUS	DEFAULT
5	GPIO[5] Output Data	RW	GPIO[5] Output Data The value written to this bit is driven to GPIO[5] output if GPIO[5] is configured as an output (offset 31Ch[11]=1)	Yes	0
6	GPIO[6] Output Data	RW	GPIO[6] Output Data The value written to this bit is driven to GPIO[6] output if GPIO[6] is configured as an output (offset 31Ch[13]=1)	Yes	0
7	GPIO[7] Output Data	RW	GPIO[7] Output Data The value written to this bit is driven to GPIO[7] output if GPIO[7] is configured as an output (offset 31Ch[15]=1)	Yes	0
8	GPIO[8] Output Data	RW	GPIO[8] Output Data The value written to this bit is driven to GPIO[8] output if GPIO[8] is configured as an output (offset 31Ch[17]=1)	Yes	0
9	GPIO[9] Output Data	RW	GPIO[9] Output Data The value written to this bit is driven to GPIO[9] output if GPIO[9] is configured as an output (offset 31Ch[19]=1)	Yes	0
10	GPIO[10] Output Data	RW	GPIO[10] Output Data The value written to this bit is driven to GPIO[10] output if GPIO[10] is configured as an output (offset 31Ch[21]=1)	Yes	0
11	GPIO[11] Output Data	RW	GPIO[11] Output Data The value written to this bit is driven to GPIO[11] output if GPIO[11] is configured as an output (offset 31Ch[23]=1)	Yes	0
12	GPIO[12] Output Data	RW	GPIO[12] Output Data The value written to this bit is driven to GPIO[12] output if GPIO[12] is configured as an output (offset 31Ch[25]=1)	Yes	0
13	GPIO[13] Output Data	RW	GPIO[13] Output Data The value written to this bit is driven to GPIO[13] output if GPIO[13] is configured as an output (offset 31Ch[27]=1)	Yes	0
14	GPIO[14] Output Data	RW	GPIO[14] Output Data The value written to this bit is driven to GPIO[14] output if GPIO[14] is configured as an output (offset 31Ch[29]=1)	Yes	0
15	GPIO[15] Output Data	RW	GPIO[15] Output Data The value written to this bit is driven to GPIO[15] output if GPIO[15] is configured as an output (offset 31Ch[31]=1)	Yes	0
31:16	Reserved	RsvdP	Not support.	No	0000h

9.3.134 GPIO 16-31 OUTPUT DATA REGISTER – OFFSET 334h (Port 0 Only)

BIT	FUNCTION	TYPE	DESCRIPTION	EEPROM/ I2C-SMBUS	DEFAULT
0	GPIO[16] Output Data	RW	GPIO[16] Output Data The value written to this bit is driven to GPIO[16] output if GPIO[16] is configured as an output (offset 320h[1]=1)	Yes	0
1	GPIO[17] Output Data	RW	GPIO[17] Output Data The value written to this bit is driven to GPIO[17] output if GPIO[17] is configured as an output (offset 320h[3]=1)	Yes	0
2	GPIO[18] Output Data	RW	GPIO[18] Output Data The value written to this bit is driven to GPIO[18] output if GPIO[18] is configured as an output (offset 320h[5]=1)	Yes	0
3	GPIO[19] Output Data	RW	GPIO[19] Output Data The value written to this bit is driven to GPIO[19] output if GPIO[19] is configured as an output (offset 320h[7]=1)	Yes	0
4	GPIO[20] Output Data	RW	GPIO[20] Output Data The value written to this bit is driven to GPIO[20] output if GPIO[20] is configured as an output (offset 320h[9]=1)	Yes	0
5	GPIO[21] Output Data	RW	GPIO[21] Output Data The value written to this bit is driven to GPIO[21] output if GPIO[21] is configured as an output (offset 320h[11]=1)	Yes	0
6	GPIO[22] Output Data	RW	GPIO[22] Output Data The value written to this bit is driven to GPIO[22] output if GPIO[22] is configured as an output (offset 320h[13]=1)	Yes	0
7	GPIO[23] Output Data	RW	GPIO[23] Output Data The value written to this bit is driven to GPIO[23] output if GPIO[23] is configured as an output (offset 320h[15]=1)	Yes	0

BIT	FUNCTION	TYPE	DESCRIPTION	EEPROM/ I2C-SMBUS	DEFAULT
8	GPIO[24] Output Data	RW	GPIO[24] Output Data The value written to this bit is driven to GPIO[24] output if GPIO[24] is configured as an output (offset 320h[17]=1)	Yes	0
9	GPIO[25] Output Data	RW	GPIO[25] Output Data The value written to this bit is driven to GPIO[25] output if GPIO[25] is configured as an output (offset 320h[19]=1)	Yes	0
10	GPIO[26] Output Data	RW	GPIO[26] Output Data The value written to this bit is driven to GPIO[26] output if GPIO[26] is configured as an output (offset 320h[21]=1)	Yes	0
11	GPIO[27] Output Data	RW	GPIO[27] Output Data The value written to this bit is driven to GPIO[27] output if GPIO[27] is configured as an output (offset 320h[23]=1)	Yes	0
12	GPIO[28] Output Data	RW	GPIO[28] Output Data The value written to this bit is driven to GPIO[28] output if GPIO[28] is configured as an output (offset 320h[25]=1)	Yes	0
13	GPIO[29] Output Data	RW	GPIO[29] Output Data The value written to this bit is driven to GPIO[29] output if GPIO[29] is configured as an output (offset 320h[27]=1)	Yes	0
14	GPIO[30] Output Data	RW	GPIO[30] Output Data The value written to this bit is driven to GPIO[30] output if GPIO[30] is configured as an output (offset 320h[29]=1)	Yes	0
15	GPIO[31] Output Data	RW	GPIO[31] Output Data The value written to this bit is driven to GPIO[31] output if GPIO[31] is configured as an output (offset 320h[31]=1)	Yes	0
31:16	Reserved	RsvdP	Not support.	No	0000h

9.3.135 GPIO 0-31 INTERRUPT POLARITY REGISTER – OFFSET 338h (Port 0 Only)

BIT	FUNCTION	TYPE	DESCRIPTION	EEPROM/ I2C-SMBUS	DEFAULT
31:0	GPIO Interrupt Polarity	RW	Controls whether GPIO Interrupt input is Active-Low or Active-High for the corresponding GPIOx signal. Bit[31:0] correspond to GPIO[31:0], respectively. 0b: GPIOx Interrupt input is Active-Low 1b: GPIOx Interrupt input is Active-High	Yes	0000_0000h

9.3.136 GPIO 0-31 INTERRUPT STATUS REGISTER – OFFSET 33Ch (Port 0 Only)

BIT	FUNCTION	TYPE	DESCRIPTION	EEPROM/ I2C-SMBUS	DEFAULT
31:0	GPIO Interrupt Status	RO	Indicates whether GPIO interrupt are inactive or active for the corresponding GPIOx signal. Bit[31:0] correspond to GPIO[31:0] respectively. 0b: GPIOx interrupt is inactive 1b: GPIOx interrupt is active	No	0000_0000h

9.3.137 GPIO 0-31 INTERRUPT MASK REGISTER – OFFSET 340h (Port 0 Only)

BIT	FUNCTION	TYPE	DESCRIPTION	EEPROM/ I2C-SMBUS	DEFAULT
31:0	GPIO Interrupt Mask	RW	Indicates whether GPIO interrupts are masked or not masked for the corresponding GPIOx signal. Bit[31:0] correspond to GPIO[31:0], respectively. 0b: GPIOx interrupt is unmasked 1b: GPIOx interrupt is masked	Yes	0000_0000h

9.3.138 OPERATION MODE REGISTER – OFFSET 348h (Port 0 Only)

BIT	FUNCTION	TYPE	DESCRIPTION	EEPROM/ I2C-SMBUS	DEFAULT
2:0	Reserved	RsvdP	Not support.	No	000b
5:3	pkgssel	RO	Package Bonding option, tie high/low in substrate.	No	001b
8:6	portcfg	RO	Port/lane configuration settings. 001b: 2 x4 ports 010b: 1 x4, 2 x2 ports 011b: 4 x2 ports 100b: 1 x4, 4 x1 ports 101b: 8 x1 ports Others: Reserved	No	Set by PORTCFG [2:0]
10:9	chipmode	RO	Chip operation mode selection. 00b: Normal mode 01b: iddq/mbist mode 10b: AC JTAG mode 11b: phy_mode	No	Set by CHIPMODE [1:0]
12:11	Reserved	RsvdP	Not support.	No	00b
13	ckmode	RO	Reference clock modes. 0b: base mode 1b: CDEP separate reference mode	No	Set by CKMODE
14	dma_mode	RO	0b: disable DMA 1b: enable DMA	No	0
20:15	upport_sel	RO	Upstream port selection.	No	0000_00b
21	CDEP_mode	RO	0b: disable CDEP 1b: enable CDEP	No	0
22	scan_tm	RO	0b: normal mode 1b: scan mode	No	0
23	hotplug_pin_en	RO	0b: GPIO[31:0] are GPIO pins 1b: GPIO[31:0] are used as hot plug pins	No	Set by HOT_PLUG EN_L
24	surprise_hp_en	RO	0b: disable surprise hot-plug 1b: enable surprise hot-plug	No	Set by SURPRISE_HP
25	ioe_40bit_en	RO	0b: support 16 bit IOE 1b: support 40 bit IOE	No	0
26	clkbuf_pd	RO	0b: clock buffer is in normal mode 1b: clock buffer is in power down mode	No	Set by CLKBUF_PD_L
27	pm_l1_1_en	RO	0b: GPIO[15:8] are GPIO pins 1b: GPIO[15:8] are used as CLKREQ_L[7:0]	No	Set by PM_L1_1_EN_L
30:28	I2c/smaddr_out	RO	Indicate I2C/SMBUS address[2:0]. They are decided by the status of I2C_ADDRESS[2:0] strap pins.	No	Set by I2C_ADDRESS [2:0]
31	Reserved	RO	Not Support.	No	0

9.3.139 CLOCK BUFFER CONTROL REGISTER – OFFSET 34Ch (Port 0 Only)

BIT	FUNCTION	TYPE	DESCRIPTION	EEPROM/ I2C-SMBUS	DEFAULT
7:0	Clock OE Control	RW	0b... disable clock output 1b... enable clock output	Yes	FFh
8	Clock Power Down	RW	0b... power on 1b... power down	Yes	Set by CLKBUF_PD_L
9	Control Enable	RW	0b... disable to use this register control clock buffer output 1b... enable to use this register control clock buffer output	Yes	0
10	Clock Source Sel	RW	0b... input clock buffer source is from differential clock pad 1b... input clock buffer source is from CMOS single end clock source	Yes	Set by CLKBUF_CMOS_EN_L
23:11	Reserved	RsvdP	Not support.	No	0_0h
31:24	Revision ID	RO	Revision id.	No	00h

9.3.140 LTSSM CSR 0 REGISTER – OFFSET 380h

BIT	FUNCTION	TYPE	DESCRIPTION	EEPROM/ I2C-SMBUS	DEFAULT
3:0	eq_preset_uplimited_0	RW	Define EQ evaluate upper limiter range of preset for Lane 0.	Yes	Ah
7:4	eq_preset_dnlimited_0	RW	Define EQ evaluate down limiter range of preset for Lane 0.	Yes	5h
11:8	eq_preset_uplimited_1	RW	Define EQ evaluate upper limiter range of preset for Lane 1.	Yes	Ah
15:12	eq_preset_dnlimited_1	RW	Define EQ evaluate down limiter range of preset for Lane 1.	Yes	5h
19:16	eq_preset_uplimited_2	RW	Define EQ evaluate upper limiter range of preset for Lane 2. If Lane 2 does not exist on this port, the register is reserved with a default value of 0h.	Yes	Ah
23:20	eq_preset_dnlimited_2	RW	Define EQ evaluate down limiter range of preset for Lane 2. If Lane 2 does not exist on this port, the register is reserved with a default value of 0h.	Yes	5h
27:24	eq_preset_uplimited_3	RW	Define EQ evaluate upper limiter range of preset for Lane 3. If Lane 3 does not exist on this port, the register is reserved with a default value of 0h.	Yes	Ah
31:28	eq_preset_dnlimited_3	RW	Define EQ evaluate down limiter range of preset for Lane 3. If Lane 3 does not exist on this port, the register is reserved with a default value of 0h.	Yes	5h

9.3.141 LTSSM CSR 1 REGISTER – OFFSET 384h

BIT	FUNCTION	TYPE	DESCRIPTION	EEPROM/ I2C-SMBUS	DEFAULT
3:0	eq_preset_uplimited_4	RW	Define EQ evaluate upper limiter range of preset for Lane 4. If Lane 4 does not exist on this port, the register is reserved with a default value of 0h.	Yes	Ah
7:4	eq_preset_dnlimited_4	RW	Define EQ evaluate down limiter range of preset for Lane 4. If Lane 4 does not exist on this port, the register is reserved with a default value of 0h.	Yes	5h
11:8	eq_preset_uplimited_5	RW	Define EQ evaluate upper limiter range of preset for Lane 5. If Lane 5 does not exist on this port, the register is reserved with a default value of 0h.	Yes	Ah
15:12	eq_preset_dnlimited_5	RW	Define EQ evaluate down limiter range of preset for Lane 5. If Lane 5 does not exist on this port, the register is reserved with a default value of 0h.	Yes	5h
19:16	eq_preset_uplimited_6	RW	Define EQ evaluate upper limiter range of preset for Lane 6. If Lane 6 does not exist on this port, the register is reserved with a default value of 0h.	Yes	Ah
23:20	eq_preset_dnlimited_6	RW	Define EQ evaluate down limiter range of preset for Lane 6. If Lane 6 does not exist on this port, the register is reserved with a default value of 0h.	Yes	5h
27:24	eq_preset_uplimited_7	RW	Define EQ evaluate upper limiter range of preset for Lane 7. If Lane 7 does not exist on this port, the register is reserved with a default value of 0h.	Yes	Ah
31:28	eq_preset_dnlimited_7	RW	Define EQ evaluate down limiter range of preset for Lane 7. If Lane 7 does not exist on this port, the register is reserved with a default value of 0h.	Yes	5h

9.3.142 LTSSM CSR 2 REGISTER – OFFSET 388h

BIT	FUNCTION	TYPE	DESCRIPTION	EEPROM/ I2C-SMBUS	DEFAULT
3:0	eq_preset_uplimited_8	RW	Define EQ evaluate upper limiter range of preset for Lane 8. If Lane 8 does not exist on this port, the register is reserved with a default value of 0h.	Yes	Ah
7:4	eq_preset_dnlimited_8	RW	Define EQ evaluate down limiter range of preset for Lane 8. If Lane 8 does not exist on this port, the register is reserved with a default value of 0h.	Yes	5h

BIT	FUNCTION	TYPE	DESCRIPTION	EEPROM/ I2C-SMBUS	DEFAULT
11:8	eq_preset_uplimited_9	RW	Define EQ evaluate upper limiter range of preset for Lane 9. If Lane 9 does not exist on this port, the register is reserved with a default value of 0h.	Yes	Ah
15:12	eq_preset_dnlimited_9	RW	Define EQ evaluate down limiter range of preset for Lane 9. If Lane 9 does not exist on this port, the register is reserved with a default value of 0h.	Yes	5h
19:16	eq_preset_uplimited_10	RW	Define EQ evaluate upper limiter range of preset for Lane 10. If Lane 10 does not exist on this port, the register is reserved with a default value of 0h.	Yes	Ah
23:20	eq_preset_dnlimited_10	RW	Define EQ evaluate down limiter range of preset for Lane 10. If Lane 10 does not exist on this port, the register is reserved with a default value of 0h.	Yes	5h
27:24	eq_preset_uplimited_11	RW	Define EQ evaluate upper limiter range of preset for Lane 11. If Lane 11 does not exist on this port, the register is reserved with a default value of 0h.	Yes	Ah
31:28	eq_preset_dnlimited_11	RW	Define EQ evaluate down limiter range of preset for Lane 11. If Lane 11 does not exist on this port, the register is reserved with a default value of 0h.	Yes	5h

9.3.143 LTSSM CSR 3 REGISTER – OFFSET38Ch

BIT	FUNCTION	TYPE	DESCRIPTION	EEPROM/ I2C-SMBUS	DEFAULT
3:0	eq_preset_uplimited_12	RW	Define EQ evaluate upper limiter range of preset for Lane 12. If Lane 12 does not exist on this port, the register is reserved with a default value of 0h.	Yes	Ah
7:4	eq_preset_dnlimited_12	RW	Define EQ evaluate down limiter range of preset for Lane 12. If Lane 12 does not exist on this port, the register is reserved with a default value of 0h.	Yes	5h
11:8	eq_preset_uplimited_13	RW	Define EQ evaluate upper limiter range of preset for Lane 13. If Lane 13 does not exist on this port, the register is reserved with a default value of 0h.	Yes	Ah
15:12	eq_preset_dnlimited_13	RW	Define EQ evaluate down limiter range of preset for Lane 13. If Lane 13 does not exist on this port, the register is reserved with a default value of 0h.	Yes	5h
19:16	eq_preset_uplimited_14	RW	Define EQ evaluate upper limiter range of preset for Lane 14. If Lane 14 does not exist on this port, the register is reserved with a default value of 0h.	Yes	Ah
23:20	eq_preset_dnlimited_14	RW	Define EQ evaluate down limiter range of preset for Lane 14. If Lane 14 does not exist on this port, the register is reserved with a default value of 0h.	Yes	5h
27:24	eq_preset_uplimited_15	RW	Define EQ evaluate upper limiter range of preset for Lane 15. If Lane 15 does not exist on this port, the register is reserved with a default value of 0h.	Yes	Ah
31:28	eq_preset_dnlimited_15	RW	Define EQ evaluate down limiter range of preset for Lane 15. If Lane 15 does not exist on this port, the register is reserved with a default value of 0h.	Yes	5h

9.3.144 LTSSM 0 REGISTER – OFFSET 390h

BIT	FUNCTION	TYPE	DESCRIPTION	EEPROM/ I2C-SMBUS	DEFAULT
1:0	det_times	RW	Used to set how many detect times will LTSSM execute. Max times =3 and Mini times is 1.	Yes	11b
2	force2detect	RW	Force LTSSM state stay in detect state.	Yes	0
3	force2compliance	RW	Force LTSSM send compliance pattern.	Yes	0
5:4	force_comp_rate	RW	Force LTSSM compliance in forced compliance mode.	Yes	00b
9:6	force_comp_deep_preset	RW	Force LTSSM GEN3 compliance mode's preset value.	Yes	0h
10	comp_parity_en	RW	Force GEN 1/GEN2 compliance parity. Debug only.	Yes	0
11	force2loop	RW	Force LTSSM to loopback mode	Yes	0
12	upconfig_capable	RW	Enable upconfig capability	Yes	0
13	lane_disable	RW	1: lane will be disable when it is a unused lane.	Yes	0

BIT	FUNCTION	TYPE	DESCRIPTION	EEPROM/ I2C-SMBUS	DEFAULT
17:14	sh_reset_time_sel	RW	Assert reset period on hot plug power on/power off sequence. 00b: 100 ms 01b: 300 ms 10b: 500 ms 11b: 600 ms	Yes	3h
19:18	Reserved	RsvdP	Not support.	No	00b
27:20	tx_nfts_num	RW	NFTS NUMBER.	Yes	F0h
28	Reserved	RsvdP	Not support.	No	0
29	chg_ln_width	RW	Enable change link width	Yes	0
30	up_speed_ctrl_chx	RW	Enable upstream port speed change when DL_UP in GEN 3 speed.	Yes	0
31	ltssm_debug_sel	RW	0b: the output of offset 734h is for embedded LA 1b: the output of offset 734h is for LTSSM flow	Yes	1

9.3.145 LTSSM 1 REGISTER – OFFSET 394h

BIT	FUNCTION	TYPE	DESCRIPTION	EEPROM/ I2C-SMBUS	DEFAULT
1:0	recv_eq_process_sel	RW	EQ evaluated mode. Debug only.	Yes	01b
2	comp_recv_bit_set	RW	Send compliance receive bit in loopback mode.	Yes	0
3	mrlpdc_ctrl_in	RW	Enable D3 dilink function	Yes	0
8:4	eq_eval_time	RW	Evaluate process timer selection. Debug only.	Yes	0_0000b
10:9	mrlpdc_tmr_sel	RW	When D3 dlink function is enable. This timer set PDC enable time.	Yes	00b
11	enter_loop_back	RW	LOOPBACK master enable.	Yes	0
12	infer_eidle_en	RW	Enable infer eidle function.	Yes	1
13	aspm_nack_en	RW	Enable response NACK Message when ASPM L1 DLLP request.	Yes	0
14	Hp_hot_ctr_en_reg	RW	Force mrlpdc =0. Debug only	Yes	0
15	Hp_hot_clk_en_reg	RW	Enable clock buffer. Colock do not control by SHP control.	Yes	0
19:16	Reserved	RsvdP	Not support.	No	0h
23:20	Any_phy_sts	RW	Control physys align time. Internal used only.	Yes	0h
31:24	ltssm_debug_sel	RW	Internal used only.	Yes	00h

9.3.146 LTSSM 2 REGISTER – OFFSET 398h

BIT	FUNCTION	TYPE	DESCRIPTION	EEPROM/ I2C-SMBUS	DEFAULT
15:0	detect_timer_sel	RW	Define two ltssmtdetect space. Debug only	Yes	0000h
23:16	sel_linkevalfigure	RW	Set good FOM value threshold	Yes	F0h
26:24	lane_good_sel	RW	Selection lane good condition. 00b: coefficient do not need change 01b: FOM!=00b and coefficient did not need change 10b: FOM=threshold or coefficient did not need change 11b: FOM=threshold and coefficient did not need change	Yes	000b
28:27	Eidle_sel_reg	RW	1b: Use PHY generate electrical 0b: Use internal electrical	Yes	0
29	sh_extra_reset	RW	Internal used only.	Yes	0
30	ioe_addr_sel	RW	Use register setting register to match outside IOE address. 0b: internal 1b: register setting value	Yes	0
31	ioe_40	RW	1b: Use 40 pin IOE 0b: Use 16 pin IOE	Yes	0

9.3.147 LTSSM 3 REGISTER – OFFSET 39Ch

BIT	FUNCTION	TYPE	DESCRIPTION	EEPROM/ I2C-SMBUS	DEFAULT
6:0	cfg_address_in	RW	IOE address defined by register.	Yes	00h

BIT	FUNCTION	TYPE	DESCRIPTION	EEPROM/ I2C-SMBUS	DEFAULT
7	hp_scl_clk_sel_in	RW	I2C clock rate. 0b: 62Khz 1b: 31Khz	Yes	0
15:8	aspm_l1_cnt_num	RW	Accumulated I0s number to enter ASPM L1 condition.	Yes	08h
31:16	aspm_l1	RW	ASPM L1 idle timer.	Yes	0FFh

9.3.148 LTSSM 4 REGISTER – OFFSET 3A0h

BIT	FUNCTION	TYPE	DESCRIPTION	EEPROM/ I2C-SMBUS	DEFAULT
15:0	tx_swing	RW	TX swing setting by register value.	Yes	0000h
17:16	Eios_cnt	RW	Polling compliance exit condition.	Yes	1
18	Bypass_detect	RW	Ignore LTSSM detect result and use max lane width.	Yes	0
19	Detection_option	RW	1b: use detection result 0b: use modify detection result	Yes	0
20	Stand_by	RW	Used to control whether the PHY rx is active when PHY is in P0 or P0s. 1b: Active 0b: Standby	Yes	0
21	In_progress	RW	Set rxeqprocess behavior. Internal used only.	Yes	0
22	Deskew_rxeqval	RW	Set deskew behavior in EQ period. Internal used only.	Yes	0
23	Ltssm_cfg2loop_sel	RW	Cfg go to loopback condition. 0b : see any loopback bit 1b: see all loopback bit. Internal used only.	Yes	0
27:24	Recv_eq_optionl	RW	Eq_option. bit[0]... set eq_valid =1	Yes	0001b
31:28	Ltssm_cfg_reversal	RW	Select reversal condition. Internal used only.	Yes	0

9.3.149 LTSSM 5 REGISTER – OFFSET 3A4h

BIT	FUNCTION	TYPE	DESCRIPTION	EEPROM/ I2C-SMBUS	DEFAULT
15:0	tskp_gen1_n0_reg	RW	When sris support, use this skip value.	Yes	004Bh
31:16	skp_gen1_reg	RW	When sris disable, use the skip value.	Yes	0258h

9.3.150 LTSSM 6 REGISTER – OFFSET 3A8h

BIT	FUNCTION	TYPE	DESCRIPTION	EEPROM/ I2C-SMBUS	DEFAULT
15:0	tskp_gen3_n0_reg	RW	When sris support, use this skip value.	Yes	011Ch
31:16	tskp_gen3_reg	RW	When sris disable, use the skip value.	Yes	0BBEh

9.3.151 LTSSM 7 REGISTER – OFFSET 3ACh

BIT	FUNCTION	TYPE	DESCRIPTION	EEPROM/ I2C-SMBUS	DEFAULT
4:0	ltssm_rx_mask_reg	RW	bit[0]... mask hot reset bit bit[1]... mask disable bit bit[2]... mask loopback bit bit[3]... mask disable scrambling bit bit[4]... mask compliance bit	Yes	0_0000b
5	ltssm_port_split_ctr_reg	RW	0b: enable port split 1b: disable port split	Yes	0
9:6	ltssm_lg_idle_cnt_reg	RW	Used to set idle data receive date number.	Yes	6h
10	ltssm_chg_rate_ms_reg	RW	Used to control down port change rate as a master.	Yes	0

BIT	FUNCTION	TYPE	DESCRIPTION	EEPROM/ I2C-SMBUS	DEFAULT
11	gpio_in_reg_tmp	RW	In external I2C IOE bit[6], it is GPIO bit.	Yes	0
15:12	ltssm_config_rev_num_reg	RW	bit[1:0]... cfg.linkaccept to cfg.linkwait counter selection. bit[3:2]... cfg.lanenum to cfg.cpl counter selection	Yes	0000b
16	ltssm_config_delay_cnt_reg	RW	cfg.start delay time to cfg.linkaccept. Use this delay time to decide partial lane detection.	Yes	0
17	disable_cfg_lane_chg_reg	RW	disable cfg.linkaccept state change lane.	Yes	0
18	disable_cfg_lane_time_reg	RW	disable cfg.lanenum to detect state.	Yes	0
22:19	partial_lane_sel_reg	RW	bit[1:0]... decide partial lane reverse bit[2]... Reserved bit[3]... delay cfg.start to cfg.linaccept sate for cross link	Yes	0001b
23	enable_bacon_l2_reg	RW	Used to enable L2 send bacon signal.	Yes	0
24	Reserved	RsvdP	Not support.	No	0
26:25	lane_change_ctr_reg	RW	Used to control lane number change in cfg state.	Yes	00b
28:27	poll_exit_comp_cnt_reg	RW	Used to set poll.compliance exit counter.	Yes	11b
29	led_mode_prsnt_sel_reg	RW	Used to select present detect pin come from IOE or IO pin in surprise mode.	Yes	1
30	shp_rest_ctr_reg	RW	Used to control ip_core reset pin come from reset_top or shp generation. 0b: come from shp generation 1b: come from reset_top	Yes	0
31	always_wait_linkup_reg	RW	In shp control, shp try to link up device always.	Yes	0

9.3.152 LTSSM 8 REGISTER – OFFSET 3B0h

BIT	FUNCTION	TYPE	DESCRIPTION	EEPROM/ I2C-SMBUS	DEFAULT
0	dpc_error_latch	RW	When dpc error occurs, ltssm will entry to disable state. 0b: dpc error signal will be latched until ltssm go to disable state. 1b: dpc error signal will not be latched.	Yes	1
1	any_phy_sts_tmp_sel_reg	RW	0b: come from all phy_sts 1b: combine with lane detection.	Yes	0
5:2	cfg_stat_ctr_reg	RW	cfg_start option selection.	Yes	0000b
19:6	rate_chg_ctr_reg	RW	Used to control rate change behavior.	Yes	0-0b
23:20	loop_test_ctr_reg	RW	loop test behavior control.	Yes	0h
25:24	l0_power_dn_wait_reg	RW	When receive/transmitter eos, pm control wait 50 cycle time to L1/l0s/L2. 00b: 50 01b: 1Fh 10b: FFh 11b: FFFFh	Yes	00b
26	gen3_phy_pm_idle_control_reg	RW	0b: use rxidle in PM 1b: ignore rxidle in PM	Yes	0
27	eq1to0_eval_reg	RW	0b: disable skip eq23 1b: skip eq23	Yes	0
30:28	debounce_sel_reg	RW	bit[1:0]... attention button/present detection de-bounce timer. 00b: C00h 01b: FFFh 10b: 600h 11b: 0FFh bit[2]... de-bounce enable	Yes	100b
31	Reserved	RsvdP	Not support	No	0

9.3.153 LTSSM 9 REGISTER – OFFSET 3B4h

BIT	FUNCTION	TYPE	DESCRIPTION	EEPROM/ I2C-SMBUS	DEFAULT
0	clear_rx_sts_err_counter	WO	Reading returns 0 always. Writing 1 will clear rx status error counter.	Yes	0
1	redo_eq_ctrl	RW	1b: redo eq when rx error > static_counter set by bit[15:8] in GEN3	Yes	0
2	static_enable_reg	RW	1b: enable perform downstream port eq when error	Yes	0
3	perform_eq_err_reg	RW	1b: when rx error occurred enable to perform redo eq 0b: disable	Yes	0
4	static_enable_up_reg	RW	1b: enable up port execute eq when rx error count > static_counter set by bit[15:8]	Yes	0
7:5	Reserved	RsvdP	Not support.	No	000b
15:8	static_ctrl_sel_num	RW	Used to set static_counter.	Yes	01h
31:16	rx_sts_err_counter	RO	Reading returns rx status error counter value. Writing this register will result in undefined behavior.	No	0000h

9.3.154 LTSSM 10 REGISTER – OFFSET 3B8h

BIT	FUNCTION	TYPE	DESCRIPTION	EEPROM/ I2C-SMBUS	DEFAULT
19:0	CLKREQ_L Wait Time	RW	<p>Once entering L1.1 power state, the port will deassert CLKREQ_L immediately. However, CLKREQ_L signal is an open-drain wire-or signal with the link partner. If the link partner does not deassert CLKREQ_L for a certain period of time, which is defined by CLKREQ_L Wait Time, the port will assert CLKREQ_L again to resume back to L1 state.</p> <p>The CLKREQ_L wait time decides how long the switch will wait for CLKREQ_L being deasserted by the link partner. The unit is “10 ns”.</p> <p>Reset to F_FF00h. It is about 10 ms.</p>	Yes	F_FF00h
20	up_entry_l1.1	RW	0b: enable up port can entry to L1.1	Yes	0
21	dn_entry_l1.1	RW	0b: enable down port can entry to L1.1	Yes	0
31:22	Reserved	RsvdP	Not support.	No	000h

9.3.155 LTSSM 11 REGISTER – OFFSET 3BCh

BIT	FUNCTION	TYPE	DESCRIPTION	EEPROM/ I2C-SMBUS	DEFAULT
0	hp_scl_clk_sel_in_dly_tmp	RW	Used to set hp_i2c delay counter.	Yes	0
2:1	recv_for_ts12_num_reg	RW	Used to set receive change bit number that fire rec.cfg change to rec.speed.	Yes	10b
3	poll_exit_comp_cnt_sel_reg	RW	Used to control poll.compliance exit.	Yes	0
6:4	loop_test_ctr_eios_reg	RW	Used to set receiveeios number in loop.exit state.	Yes	010b
7	shp_command_dis_em_reg	RW	Used to check electromechanical control combine with set slot command.	Yes	0
15:8	pm_phy_rxeidle_cnt_sel_reg	RW	Used to control Pm phy rxeidle counter.	Yes	01h
31:16	cfg_cnt_ctr_reg	RW	Used to control ltssm cfg state.	Yes	9C49h

9.3.156 LTSSM 12 REGISTER – OFFSET 3C0h

BIT	FUNCTION	TYPE	DESCRIPTION	EEPROM/ I2C-SMBUS	DEFAULT
0	dis_ini_hw_dis	RW	0b: disable hardware autonomous speed bit in link control 2 register 1b: enable	Yes	0

BIT	FUNCTION	TYPE	DESCRIPTION	EEPROM/ I2C-SMBUS	DEFAULT
1	up_hot_reset	RW	0b: upstream port does not send hot reset go through recovery 1b: upstream port send hot reset go through recovery	Yes	0
2	rev_ext	RW	When enable it, pm will check recovery state and pm state is 0 then exit to I0.	Yes	0
3	rev_ext1	RW	When enable it, ltssm check rxidle in ltssm I1 state. If rxidle is low, ltssm I1 will jump to I0.	Yes	0
7:4	par_idle_sel	RW	bit[0]: when set, ignore fts packet to generate gen3 rxidle. bit[1]: when set, ignore ts1 packet to generate gen3 rxidle. bit[2]: when set, ignore ts2 packet to generate gen3 rxidle. bit[3]: when set, ignore eos packet to generate gen3 rxidle.	Yes	1000b
15:8	I1_rev_ext1_cnt	RW	When wire I1_rev_ext1_reg is enabled, the counter use to evaluate high for rxidle.	Yes	1Fh
23:16	pm_phy_rxidle_cnt_sel1_reg	RW	Stay in I1 counter; I1 to I0 counter. It make sure all conditions are meet. It is used for test mode only.	Yes	06h
24	ack_nak_empty_o_reg	RW	0b: check ack or nack is empty when I0 to I1. 1b: do not check ack or nack is empty when I0 to I1.	Yes	0
25	eq_start_ctrl_reg	RW	0b: get coefficient do not check whether state in eq state. 1b: get coefficient check whether state in eq state.	Yes	0
26	dis_change_rate_coef_reg	RW	0b: enable change lane width change function. 1b: disable lane width change function.	Yes	0
28:27	eios_ctrl_reg_0	RW	Used to check receive eios counter in change rate stage.	Yes	00b
31:29	eios_ctrl_reg_1	RW	Used to send eios number in change rate.	Yes	100b

9.3.157 LTSSM 13 REGISTER – OFFSET 3C4h

BIT	FUNCTION	TYPE	DESCRIPTION	EEPROM/ I2C-SMBUS	DEFAULT
7:0	transmit idle data number[7:0]	RW	Used to set transmit idle data number.	Yes	08h
11:8	receive idle data[3:0]	RW	Used to set receive idle data.	Yes	8h
12	disable_pol2loop_reg	RW	1b: enable pol2loop 0b: disable pol2loop	Yes	0
14:13	Reserved	RsvdP	Not support.	No	10b
15	Forced to Gen 3	RW	Forced the downstream port trying to link at Gen 3 speed if the link partner reporting Gen 3 link capability. 0b: No trying (i.e. linked at whatever speed per standard flow) 1b: Keep trying to change rate to Gen 3 until success	Yes	0
23:16	cfg_ctrl_sub_reg [7:0]	RW	Used to set cfg_ctrl_sub register.	Yes	06h
25:24	rate_eq_ctr2_reg [1:0]	RW	Used to set rate_eq_ctr2 register.	Yes	00b
29:26	eq_done_8g_ctr_reg[3:0]	RW	Used to set eq_done_8g_ctrl register.	Yes	0110b
31:30	up_have_rcv_eq1_reg[1:0]	RW	Used to set up_have_rcv_eq1 register.	Yes	00b

9.3.158 LTSSM 14 REGISTER – OFFSET 3C8h

BIT	FUNCTION	TYPE	DESCRIPTION	EEPROM/ I2C-SMBUS	DEFAULT
3:0	lane_sel_cnt	RW	Select lane preset which eq negotiate result.	Yes	0h
7:4	sphp_ctrl_reg	RW	Serial hot plug controller for power control option 0.	Yes	0h
9:8	pme_to_ack_timer_reg	RW	Pme to ack response timer selection.	Yes	00b
10	send_pack_on_time_reg	RW	Send link up/all port enter idle message to main tie at fixed time.	Yes	0
19:11	disable_eios_reg	RW	Pm idle option.	Yes	0-0b
20	diabile_hot_reset_reg	RW	0b: hotreset state send ts1 after sds send at recovery state 1b: hotreset state send ts1 directly	Yes	0
23:21	recovery_idle_count	RW	Used to configure recovery idle send amount of additional idle symbol number.	Yes	000b
27:24	eq_number_ask	RO	EQ number that DUT ask number to link partner.	No	0h

BIT	FUNCTION	TYPE	DESCRIPTION	EEPROM/ I2C-SMBUS	DEFAULT
31:28	eq_number_applied	RO	EQ number that come from link partner.	No	0h

9.3.159 LTSSM 15 REGISTER – OFFSET 3CCh

BIT	FUNCTION	TYPE	DESCRIPTION	EEPROM/ I2C-SMBUS	DEFAULT
0	pwr_det_ctrl	RW	Used to enable power saing function at empty port. 0b: disable power saving function at empty port 1b: enable power saving function at empty port	Yes	0
1	recovery_ctrl	RW	When set 1, entry to recovery will ignore rx is in I0s.	Yes	0
2	fake_oder_set_done	RW	When set 1, ltssm will auto generate order set done sinal when ltssm set pipe_tx_os signal large than ff cycle time.	Yes	0
3	disable_skip_at_10	RW	When set 1, send skip signal will extend until send skip packet done.	Yes	0
7:4	disable_reject	RW	Used to control reject bit behavior on ts order set at eq process.	Yes	0h
23:8	comp_ctrl_gen1/2	WO	Used to control compliance pattern behavior on gen1/gen2.	Yes	0000h
31:24	Reserved	RsvdP	Not support.	No	00h

9.3.160 DLL CSR 0 REGISTER – OFFSET 420h

BIT	FUNCTION	TYPE	DESCRIPTION	EEPROM/ I2C-SMBUS	DEFAULT
11:0	GEN1_ACK_LATENCY_CTRL	RW	bit[11]: user enable bit[10:0]: user define ACK latency value	Yes	800h for Up 000h for Down
15:12	Reserved	RsvdP	Not support.	No	0h
16	BLOCK_BUMP_DET	RO	Block list has been overrun.	No	0
27:17	Reserved	RsvdP	Not support.	No	0_0b
28	TLP_NO_EOF_ERR_DFT	RO	Detecting TLP has no end of frame.	No	0
29	TLP_HEADER_ERR_DET	RO	Detecting header of TLP is wrong.	No	0
30	FIFO_LTH_ERR_A BORT_DET	RO	Detecting total length of TLP is abort.	No	0
31	FIFO_LTH_ERR_DET	RO	Detecting total length of TLP is wrong.	No	0

9.3.161 DLL CSR 1 REGISTER – OFFSET 424h

BIT	FUNCTION	TYPE	DESCRIPTION	EEPROM/ I2C-SMBUS	DEFAULT
11:0	GEN2_ACK_LATENCY_CTRL	RW	Bit[11]: user enable Bit[10:0]: user define ACK latency value	Yes	800h for Up 000h for Down
15:12	Reserved	RsvdP	Not support.	No	0h
16	BLOCK_BUMP_DET	RO	Block list has been overrun.	No	0
27:17	Reserved	RsvdP	Not support.	No	0_0b
28	TLP_NO_EOF_ERR_DFT	RO	Detecting TLP has no end of frame.	No	0
29	TLP_HEADER_ERR_DET	RO	Detecting header of TLP is wrong.	No	0
30	FIFO_LTH_ERR_A BORT_DET	RO	Detecting total length of TLP is abort.	No	0
31	FIFO_LTH_ERR_DET	RO	Detecting total length of TLP is wrong.	No	0

9.3.162 DLL CSR 2 REGISTER – OFFSET 428h

BIT	FUNCTION	TYPE	DESCRIPTION	EEPROM/ I2C-SMBUS	DEFAULT
11:0	GEN3_ACK_LATENCY_CTRL	RW	bit[11]: user enable bit[10:0]: user define ACK latency value	Yes	800h for Up 000h for Down
15:12	Reserved	RsvdP	Not support.	No	0h
16	BLOCK_BUMP_DET	RO	Block list has been overrun.	No	0
27:17	Reserved	RsvdP	Not support.	No	0_0b
28	TLP_NO_EOF_ERR_DFT	RO	Detecting TLP has no end of frame.	No	0
29	TLP_HEADER_ERR_DET	RO	Detecting header of TLP is wrong.	No	0
30	FIFO_LTH_ERR_ABORT_DET	RO	Detecting total length of TLP is abort.	No	0
31	FIFO_LTH_ERR_DET	RO	Detecting total length of TLP is wrong.	No	0

9.3.163 DLL CSR 3 REGISTER – OFFSET 42Ch

BIT	FUNCTION	TYPE	DESCRIPTION	EEPROM/ I2C-SMBUS	DEFAULT
11:0	GEN1_REPLAY_TIMER_CTRL	RW	User defined replay timeout value for GEN1.	Yes	000h
12	User_define_GEN1_REPLAY_TIMER	RW	0b: disable user defined replay timer for GEN1 1b: enable user defined replay timer for GEN1	Yes	0b
21:13	retry buffer threshold for 128	RW	Used to set retry buffer threshold for 128 payload.	Yes	1F1h
30:22	retry buffer threshold for 256	RW	Used to set retry buffer threshold for 256 payload.	Yes	1F0h
31	tx ready non valid error by transaction layer	RW1C	For internal used.	Yes	0

9.3.164 DLL CSR 4 REGISTER – OFFSET 430h

BIT	FUNCTION	TYPE	DESCRIPTION	EEPROM/ I2C-SMBUS	DEFAULT
11:0	GEN2_REPLAY_TIMER_CTRL	RW	User defined replay timeout value for GEN2.	Yes	000h
12	User_define_GEN2_REPLAY_TIMER	RW	0b: disable user defined replay timer for GEN2 1b: enable user defined replay timer for GEN2	Yes	0b
21:13	retry buffer threshold for 512	RW	Used to set retry buffer threshold for 512 payload.	Yes	1E0h
23:22	External dlp_tx_block_ctrl	RW	Internal used only.	Yes	11b
31:24	Internal dlp_tx_block_ctrl	RW	Internal used only	Yes	FBh

9.3.165 DLL CSR 5 REGISTER – OFFSET 434h

BIT	FUNCTION	TYPE	DESCRIPTION	EEPROM/ I2C-SMBUS	DEFAULT
11:0	GEN3_REPLAY_TIMER_CTRL	RW	User defined replay timeout value for GEN2	Yes	000h
12	User_define_GEN3_REPLAY_TIMER	RW	0b: disable user defined replay timer for GEN3 1b: enable user defined replay timer for GEN3	Yes	0b
13	reserved	RO	Not support	No	0b
15:14	Loopback synchronous signal	RO	Internal used only.	No	0h
27:16	Loopback error count	RW1C	Only bit 16 write one to clear count.	No	0h

BIT	FUNCTION	TYPE	DESCRIPTION	EEPROM/ I2C-SMBUS	DEFAULT
29:28	DLP TX control	RW	Internal used only.	Yes	01b
30	Loopback insert error	RW	User insert error to loopback	Yes	0b
31	Loopback packet start	RW	Start loopback packet.	Yes	0b

9.3.166 DLL CSR 6 REGISTER – OFFSET 438h

BIT	FUNCTION	TYPE	DESCRIPTION	EEPROM/ I2C-SMBUS	DEFAULT
6:0	INI_FLOW_CTRL	RW	bit[2:0]: The value of firing initial flow control after getting flow control from frond end bit[3]: user enable bit[4]: enable to make initial flow control 1 transfer to initial flow control 2 early by getting any TLP or initial flow control 2 bit[5]: enable to make initial flow control 2 transfer to initial done by getting any TLP bit[6]: enable to make initial flow control to initial done by getting any good TLP or update flow control	Yes	70h
7	INI_FLOW2_EN	RW	Don't need initial flow control 2.	Yes	0
8	Dis_replaytimer_rx	RW	Used to disable Replay timer enable in RX L0s.	Yes	1
9	Dis_replaytimer_tx	RW	Used to disable Replay timer enable in TX L0s.	Yes	0
10	En_duplicate_seq_nak	RW	Used to enable duplicate sequence number for NAK.	Yes	0
11	En_bypass_flowctrl	RW	Used to bypass initial flow control 1 to TL.	Yes	1
12	Rx_polarity_force_en	RW	Used to enable RX polarity force.	Yes	0
15:13	Reserved	RsvdP	Not support.	No	000b
31:16	Rx_polarity_value	RW	Used to set rx polarity value for 16 lanes.	Yes	0000h

9.3.167 DLL CSR 7 REGISTER – OFFSET 43Ch

BIT	FUNCTION	TYPE	DESCRIPTION	EEPROM/ I2C-SMBUS	DEFAULT
8:0	DLL_DEBUG_SEL	RW	Data link layer debug select.	Yes	0_0b
9	DLL Error Enable	RW	Used to enable or disable DLL Error report to AER. 0b: disable 1b: enable	Yes	1
10	TLP Error Enable	RW	Used to enable or disable TLP Error report to AER.	Yes	1
11	DLL Protocol Error Enable_Disable	RW	Used to enable or disable DLL Protocol Error report to AER. 0b: disable for P1~P7 and enable for P0 and P4 1b: enable for P1~P7 and disable for P0 and P4	Yes	1
12	Receive Error Enable	RW	Used to enable or disable Receive Error to AER. 0b: disable 1b: enable	Yes	1
16:13	MAC ERR extend control	RW	Internal used only.	Yes	7h
18:17	EIOS amount control	RW	Internal used only.	Yes	00b
24:19	DLL rx control	RW	Internal used only.	Yes	7h
29:25	Reserved	RsvdP	Not support.	No	0_0h
31:30	Loopback mode status	RO	Indicate loopback mode status.	No	00b

9.3.168 DLL CSR 8 REGISTER – OFFSET 440h

BIT	FUNCTION	TYPE	DESCRIPTION	EEPROM/ I2C-SMBUS	DEFAULT
12:0	ERR_CTRL_500M	RW	bit[0]: EIEOS error status enable bit[1]: SKIP on data stream error status enable bit[2]: NFTS error status enable bit[3]: SKIP framing error status enable bit[4]: GEN3 logical idle error status enable bit[5]: EDS token to get FTS error status enable bit[6]: GEN3 FCRC error status enable bit[7]: GEN3 EDB token error status enable bit[8]: GEN3 TLP framing error status enable bit[9]: TLP Framing check enable bit[10]: GEN1/2 TLP framing error status error enable bit[11]: GEN1/2 PAD framing error status enable bit[12]: GEN1/2 SDP framing error status enable	Yes	000h
13	GEN1/2_framing_err_en	RW	GEN1/2 framing error enable.	Yes	0
14	Recovery_enable_for_err_detect	RW	Recovery enable for error detect.	Yes	1
15	Recovery_for_replay_rollover	RW	Replay rollover to recovery enable.	Yes	1
16	GEN3_sync_header_err_detect	RW	GEN3 synchronous header error detect.	Yes	1
17	PHY_err_detect_en	RW	PHY status error detect enable.	Yes	1
18	GEN3_skip_back2_back_err_detect	RW	GEN3 SKIP back 2 back error detect.	Yes	0
19	Elastic_buf_overrun_detect	RW	Elastic buffer overrun detect.	Yes	0
20	Elastic_buf_underrun_detect	RW	Elastic buffer underrun detect.	Yes	0
21	GEN3_decode_error_detect	RW	GEN3 decode error detect.	Yes	0
22	Recovery_lane_detect_error_en	RW	Enable Lane detect error to recovery.	Yes	1
23	Recovery_ordered_set_error_en	RW	Enable ordered set error to recovery.	Yes	0
31:24	Recovery_rx_error_amount	RW	RX status error amount to recovery.	Yes	03h

9.3.169 DLL CSR 9 REGISTER – OFFSET 444h

BIT	FUNCTION	TYPE	DESCRIPTION	EEPROM/ I2C-SMBUS	DEFAULT
15:0	GEN3_FC_LIFE_CTRL_POST	RW	bit[15]: user define update flow control life cycle enable for post bit[14]: reserved bit[13:2]: user define update flow control life cycle value for post bit[1:0]: reserved	Yes	0000h
31:16	GEN2_FC_LIFE_CTRL_POST	RW	bit[15]: user define update flow control life cycle enable for post bit[14]: reserved bit[13:2]: user define update flow control life cycle value for post bit[1:0]: reserved	Yes	0000h

9.3.170 DLL CSR 10 REGISTER – OFFSET 448h

BIT	FUNCTION	TYPE	DESCRIPTION	EEPROM/ I2C-SMBUS	DEFAULT
15:0	GEN3_FC_LIFE_CTRL_NP	RW	bit[15]: user define update flow control life cycle enable for non-post bit[14]: reserved bit[13:2]: user define update flow control life cycle value for non-post bit[1:0]: reserved	Yes	0000h

BIT	FUNCTION	TYPE	DESCRIPTION	EEPROM/ I2C-SMBUS	DEFAULT
31:16	GEN2_FC_LIFE_CTRL_NP	RW	bit[15]: user define update flow control life cycle enable for non-post bit[14]: reserved bit[13:2]: user define update flow control life cycle value for non-post bit[1:0]: reserved	Yes	0000h

9.3.171 DLL CSR 11 REGISTER – OFFSET 44Ch

BIT	FUNCTION	TYPE	DESCRIPTION	EEPROM/ I2C-SMBUS	DEFAULT
15:0	GEN3_FC_LIFE_CTRL_CPL	RW	bit[15]: user define update flow control life cycle enable for completion bit[14]: reserved bit[13:2]: user define update flow control life cycle vaule for completion bit[1:0]: reserved	Yes	0000h
31:16	GEN2_FC_LIFE_CTRL_CPL	RW	bit[15]: user define update flow control life cycle enable for completion bit[14]: reserved bit[13:2]: user define update flow control life cycle value for completion bit[1:0]: reserved	Yes	0000h

9.3.172 DLL CSR 12 REGISTER – OFFSET 450h

BIT	FUNCTION	TYPE	DESCRIPTION	EEPROM/ I2C-SMBUS	DEFAULT
0	SKIP_LFSR_CTRL_500M	RW	GEN3 LFSR value correct enable by SKIP.	Yes	1
1	tlp_payload_ignore_detect	RW	TLP payload ignore detect.	Yes	0
2	x16_tlp_back2back_cal_en	RW	For x16 TLP back 2 back calculate enable for receiver.	Yes	0
3	Force_disable_tlp_send	RW	Force to disable TLP sent when TLP empty.	Yes	1
6:4	GEN3_de-skew_reset_count	RW	GEN3 de-skew reset count.	Yes	111b
7	GEN3_rx_idle_en	RW	GEN3 RX electric idle enable for data valid or not.	Yes	1
10:8	GEN1/2_de-skew_reset_count	RW	GEN1/2 de-skew reset count.	Yes	111b
27:11	Reserved	RsvdP	Not support.	No	0050h
31:28	x16_tlp_back2back_count	RO	x16 TLP back 2 back count. Use bit 2 to clear.	Yes	0h

9.3.173 DLL CSR 13 REGISTER – OFFSET 454h

BIT	FUNCTION	TYPE	DESCRIPTION	EEPROM/ I2C-SMBUS	DEFAULT
0	NULLIFIED_FLAG_500M	RO	Nullified TLP detect.	No	0
1	ENDING_FLAG_500M	RO	Ending of TLP is not consistent to total length.	No	0
2	SEQ_NUM_ERR_DET	RO	Sequel number wrong.	No	0
3	BUFFER_FULL_DET	RO	Retry buffer is full.	No	0
4	ECC_Correct	RO	ECC correctable detect error.	No	0
5	ECC_Uncorrect	RO	ECC uncorrectable detect error.	No	0
6	REPLAY__DET	RO	Replay timeout detect.	No	0
7	CRC16_DET	RO	SDP of data link layer of CRC error detect.	No	0
8	CRC32_DET	RO	TLP of data link layer of CRC error detect.	No	0

BIT	FUNCTION	TYPE	DESCRIPTION	EEPROM/ I2C-SMBUS	DEFAULT
9	CRC32_NULL_DET	RO	TLP of data link layer of nullified CRC detect.	No	0
11:10	Reserved	RsvdP	Not support.	No	00b
14:12	RX PM ACK Number	RW	Used to set rx PM ACK number. The range is from 0 to 6.	Yes	011b
15	Reserved	RsvdP	Not support.	No	1
18:16	TX PM ACK Number	RW	Used to send tx PM ACK number. The range is from 0 to 6.	Yes	000b
31:19	Reserved	RsvdP	Not support. If the link is x16, the default value is 11E3h. Otherwise, the default value is 01E3h	No	03E3h or 01E3h

9.3.174 DLL CSR 14 REGISTER – OFFSET 458h

BIT	FUNCTION	TYPE	DESCRIPTION	EEPROM/ I2C-SMBUS	DEFAULT
11:0	RX_NAK_SEQ_NUM	RO	NAK sequence number record for receiver.	Yes	000h
14:12	Reserved	RsvdP	Not support.	No	000b
15	RX_NAK_FLAG	RO	NAK flag asserted of receiver.	No	0
27:16	TX_NAK_SEQ_NUM	RO	NAK sequence number record for transmitter.	Yes	000h
30:28	Reserved	RsvdP	Not support.	No	000b
31	TX_NAK_FLAG	RO	NAK flag asserted of transmitter.	No	0

9.3.175 DLL CSR 15 REGISTER – OFFSET 45Ch

BIT	FUNCTION	TYPE	DESCRIPTION	EEPROM/ I2C-SMBUS	DEFAULT
0	Nullified Enable	RW	When set, enable to generated nullified packet.	Yes	1
1	Data Link Layer Reset	RW1C	Reset of data link layer.	Yes	0
2	TLP Ending Choice	RW	TLP of Ending choice by length or write to buffer.	Yes	0
3	Block List Full Select	RW	TLP Block list full select enable.	Yes	0
7:4	RxReceive Threshold Value	RW	Rx receive threshold value.	Yes	8h
8	x16 Low Latency Enable	RW	x16 low latency enable when common mode.	Yes	0
9	x16 Synchronous Mode	RW	x16 Tx synchronous enable when common mode.	Yes	0
12:10	GEN1_FTS_skew_Range_value	RW	GEN1 FTS skew range value.	Yes	011b
15:13	GEN2_FTS_skew_Range_value	RW	GEN2 FTS skew range value.	Yes	001b
19:16	GEN1_de-skew_range_value	RW	GEN1 de-skew range value.	Yes	Ch
23:20	GEN2_de-skew_range_value	RW	GEN2 de-skew range value.	Yes	Ch
27:24	GEN3_de-skew_Rnage_value	RW	GEN3 de-skew range value.	Yes	Ch
28	LO State and Non valid for Surprise Disconnect	RW	Internal used only.	Yes	0
29	Port Bifurcating Enable	RW	When set, enable port bifurcating function.	Yes	0
30	Skip_mask_select_en	RW	SKIP mask select enable for DLP.	Yes	0
31	Reserved	RsvdP	Not support.	No	0

9.3.176 DLL CSR 16 REGISTER – OFFSET 460h

BIT	FUNCTION	TYPE	DESCRIPTION	EEPROM/ I2C-SMBUS	DEFAULT
31:0	DLL_TX_DEBUG_i	RO	Internal used only.	No	0000_0070h

9.3.177 DLL CSR 17 REGISTER – OFFSET 464h

BIT	FUNCTION	TYPE	DESCRIPTION	EEPROM/ I2C-SMBUS	DEFAULT
31:0	DLL_RX_DEBUG_i	RO	Internal used only.	No	0000_0000h

9.3.178 DLL CSR 18 REGISTER – OFFSET 468h

BIT	FUNCTION	TYPE	DESCRIPTION	EEPROM/ I2C-SMBUS	DEFAULT
31:0	MAC_TX_DEBUG_i	RO	Internal used only.	No	0098_0029h

9.3.179 DLL CSR 19 REGISTER – OFFSET 46Ch

BIT	FUNCTION	TYPE	DESCRIPTION	EEPROM/ I2C-SMBUS	DEFAULT
31:0	MAC_RX_DEBUG_i	RO	Internal used only.	No	0000_0000h

9.3.180 LA DEBUG REGISTER – OFFSET 470h

BIT	FUNCTION	TYPE	DESCRIPTION	EEPROM/ I2C-SMBUS	DEFAULT
3:0	initial flow control 2	RW	Internal used only.	Yes	1011b
4	flow control life cycle synchronous	RW	Internal used only.	Yes	0
5	initial flow control 2 expire enable	RW	Internal used only.	Yes	0
6	GEN3 auto change lane width	RW	Internal used only.	Yes	1
7	de-skew delay time disable	RW	Internal used only.	Yes	1
31:8	msic	RW	Internal used only.	Yes	7000_00h

9.3.181 TL CSR 0 REGISTER – OFFSET 4C0h

BIT	FUNCTION	TYPE	DESCRIPTION	EEPROM/ I2C-SMBUS	DEFAULT
0	decode_vga	RW	0b: disable VGA decode 1b: enable VGA decode	Yes	1
1	msi_cap_dis	RO	0b: enable MSI capability 1b: disable MSI capability	Yes	0
2	pwr_cap_dis	RO	0b: enable power capability 1b: disable power capability	Yes	0
3	mf_credit_update_dis	RO	Internal used only.	Yes	0
4	mc_cap_dis	RO	Internal used only.	Yes	0
5	mem_sharing_dis	RO	0b: enable memory sharing 1b: disable memory sharing It is set by Port 0 only. When set, it will affect the entire switch.	Yes	0
7:6	Reserved	RsvdP	Not support.	No	00b
8	p_inta_slot	RW	Internal used only.	Yes	0
9	p_inta_gpio	RW	Internal used only.	Yes	0

BIT	FUNCTION	TYPE	DESCRIPTION	EEPROM/ I2C-SMBUS	DEFAULT
10	p_inta_ntl	RW	Internal used only.	Yes	0
11	Reserved	RsvdP	Not support.	No	0
13:12	initial credit threshold	RO	Internal used only.	Yes	00b
31:14	Reserved	RsvdP	Not support.	No	0-0h

9.3.182 TL CSR 1 REGISTER – OFFSET 4C4h

BIT	FUNCTION	TYPE	DESCRIPTION	EEPROM/ I2C-SMBUS	DEFAULT
0	store_en	RW	When set, a store-forward mode is used. Otherwise, the chip is working under cut-through mode. It is valid for upstream port only.	Yes	0
3:1	cut-through threshold	RW	Cut-through Threshold. 00b: the threshold is set at the middle of forwarding packet 01b: the threshold is set ahead 1-cycle of middle point 10b: the threshold is set ahead 2-cycle of middle point 11b: the threshold is set ahead 3-cycle of middle point It is valid for upstream port only.	Yes	100b
4	port_arb_mode	RW	When set, the round-robin arbitration will stay in the arbitrated port even if the credit is not enough but request is pending. When clear, the round-robin arbitration will always go to the requesting port, which the outgoing credit is enough for the packet queued in the port. It is valid for upstream port only	Yes	0
5	port_order	RW	When set, there is forced ordering rule on packets for different egress port. It is valid for upstream port only.	Yes	0
6	cpl_order	RW	When set, there is forced ordering rule between completion packet with different tag. It is valid for upstream port only.	Yes	0
7	np_store_en	RW	When set, for Non-post TLP store-forward mode is used. Otherwise, Non-post TLP is working under cut-through mode. It is valid for upstream port only.	Yes	0
8	Reserved	RW	Internal used only.	Yes	0
9	datasel_rw_en	RO	When set, PM data register's DATA SEL is R/W.	Yes	0
10	Reserved	RW	Internal used only.	Yes	0
11	4k_boundary_check_en	RW	0b: disable 1b: enable 4KB boundary check	Yes	0
12	Reserved	RsvdP	Not support.	No	0
13	order_rule5_en	RW	When set, Post packet cannot pass Non-post Packet.	Yes	0
14	ordering_forzen_p_dis	RW	For Post packets.	Yes	0
15	ordering_forzen_np_dis	RW	For Non-Post packets.	Yes	1
16	RX Poison TLP mode	RW	Internal used only.	Yes	0
17	RX ECRC TLP mode	RW	Internal used only.	Yes	0
18	RX MC overlay TLP ECRC mode	RW	Internal used only.	Yes	0
31:19	Reserved	RsvdP	Not support.	No	0-0h

9.3.183 TL CSR 2 REGISTER – OFFSET 4C8h

BIT	FUNCTION	TYPE	DESCRIPTION	EEPROM/ I2C-SMBUS	DEFAULT
0	dma_cap	RO	When Set, DMA is enabled.	Yes	0
1	non_trans_	RO	When Set, non transparent mode is enabled.	Yes	0
2	Power_saving_en	RO	When set power saving mode is enabled. It is set by Port 0 only. When set, it will affect the entire switch.	Yes	1
3	Reserved	RsvdP	Not support.	No	0
4	overlay_tlp_fc_ update_mode	RW	When set, overlay tlp fc update mode is set. It is set by Port 0 only. When set, it will affect the entire switch.	Yes	1
5	egress_tlp_request_ mode	RW	When set, egress tlp request mode is set.	Yes	0
6	emulate RD TRACKING TX_READY	RW	Internal used only.	Yes	0
7	broadcast CFGWRI mode	RW	Internal used only.	Yes	0
31:8	Reserved	RsvdP	Not support.	No	0-0b

9.3.184 TL CSR 3 REGISTER – OFFSET 4CCh (Port 0 Only)

BIT	FUNCTION	TYPE	DESCRIPTION	EEPROM/ I2C-SMBUS	DEFAULT
3:0	vp port ring_csr	RO	Internal used only.	Yes	1010b
4	vp port cut through ctrl	RO	Internal used only.	Yes	0
5	Reserved	RsvdP	Internal used only.	No	0
31:6	Reserved	RsvdP	Not support.	No	0_0h

9.3.185 TL CSR 4 REGISTER – OFFSET 4D0h

BIT	FUNCTION	TYPE	DESCRIPTION	EEPROM/ I2C-SMBUS	DEFAULT
23:0	Reserved	RsvdP	Not support.	No	00_0000h
31:24	specific TL debug mode_sel	RW	Internal used only.	Yes	00h

9.3.186 DEVICE CONFIGURATION 0 REGISTER – OFFSET 504h (Port 0 Only)

BIT	FUNCTION	TYPE	DESCRIPTION	EEPROM/ I2C- SMBUS	DEFAULT
2:0	Up Port Selection	RO	Used to do up port selection. It is valid for transparent mode only.	Yes	000b
5:3	Reserved	RsvdP	Not support.	No	000b
6	Chip CD Mode	RO	Used to enable CD mode for the whole chip. 1b: enable Chip CD mode (i.e. switch operates in cross-domain mode) 0b: disable Chip CD mode (i.e. switch operates in transparent mode)	Yes	0
7	Smbus Enable	RO	Used to set SMBUS_EN_L strap pin. 0b: I2C 1b: SMBUS	Yes	Set by SMBUS_EN_L
10:8	I2C/Smbus Address	RO	Used to set I2C_ADDRESS[2:0] strap pins.	Yes	Set by I2C_ADDRESS [2:0]
11	Debug_Mode	RO	0b: disable debug mode 1b: enable debug mode	Yes	0
31:12	Reserved	RsvdP	Not support.	No	0000_0h

9.3.187 DEVICE CONFIGURATION 1 REGISTER – OFFSET 508h (Port 0 Only)

BIT	FUNCTION	TYPE	DESCRIPTION	EEPROM/ I2C-SMBUS	DEFAULT
1:0	Reserved	RsvdP	Not support.	No	00b
4:2	PORTCFG	RO	Used to set PORTCFG[2:0] strap pins.	Yes	Set by PORTCFG [2:0]
6:5	Chip Mode	RO	Used to set CHIPMODE[1:0] strap pins.	Yes	Set by CHIPMODE [1:0]
7	Fast Mode	RO	0b: disable fast mode 1b: enable fast mode, for internal used only	Yes	0
8	Ckmode	RO	Used to set CKMODE strap pin.	Yes	Set by CKMODE
31:9	Reserved	RsvdP	Not support.	No	0-0b

9.3.188 DEVICE CONFIGURATION 2 REGISTER – OFFSET 50Ch (Port 0 Only)

BIT	FUNCTION	TYPE	DESCRIPTION	EEPROM/ I2C-SMBUS	DEFAULT
0	Reserved	RsvdP	Not support.	No	0
1	HotPlug_Enable	RO	Used to enable/disable hot plug function. 0b: disable 1b: enable	Yes	Set by HOT PLUG _EN_L
2	Surprise_Hot_Plug_Disable	RO	Used to select surprise or managed hot plug function. 0b: surprise hot plug 1b: managed hot plug	Yes	Set by SURPRISE _HP
3	IOE_40Bit_Disable	RO	Used to set IOE is 16 bit or 40 bit. 0b: 40 bit IOE 1b: 16 bit IOE	Yes	0
4	Pm_L1_1_Enable	RO	Used to enable/disable PM L1.1 function. 0b: disable 1b: enable	Yes	Set by PM_L11_EN _L
7:5	Reserved	RsvdP	Not support.	No	111b
8	CLKBUF_PD	RO	Used to power down or off internal clock buffer. 0b: power on 1b: power down	Yes	Set by CLKBUFPD _L
14:9	Reserved	RsvdP	Not support.	No	000000b
15	P4_RID_Auto_Set	RO	Used to set RID table being automatically built and maintained by the switch hardware in CDLEP Port 4.	Yes	1b
17:16	Switch CD Mode	RO	Used to configure CDEP Port for this switch. 0xb: no CDEP ports configured in this switch 10b: not support 11b: one CDVEP port and one CDLEP port The setting in Switch CD Mode can be ignored if Chip CD Mode is disabled.	Yes	00b
19:18	DMA Mode	RO	Used to configure DMA Mode for this switch. 0xb: DMA functions are disabled in this switch 10b: DMA function s enabled under its own main or local hosts Switch CD Mode = 0x: DMA functions are at P0 only Switch CD Mode = 11: DMA functions are at P0 and P4 respectively 11b: DMA function only enabled under the main host domain and DMA functions are enabled at P0 only	Yes	00b
20	CLKBUF_CTL_EN	RO	Used to enable internal clock buffer outputs control.	Yes	0
21	Reserved	RsvdP	Not support.	No	0

BIT	FUNCTION	TYPE	DESCRIPTION	EEPROM/ I2C-SMBUS	DEFAULT
22	Reserved	RsvdP	Not support.	No	0
23	Reserved	RsvdP	Not support.	No	0
31:24	CLKBUF_Output_En	RO	Used to enable/disable internal clock buffer outputs REFCLKOP/N[7:0] 0b: disable 1b: enable These bits are valid when bit[20]=1.	Yes	FFh

9.3.189 DEVICE CLOCK EXTERNAL CONTROL REGISTER – OFFSET 510h (Port 0 Only)

BIT	FUNCTION	TYPE	DESCRIPTION	EEPROM/ I2C-SMBUS	DEFAULT
15:0	EE_Ext_Pclk_Req	RO	Device Ext_Pclk_Req Control from EEPROM.	Yes/No	0000h
19:16	EE_Mplla_Force_En	RO	Device Mplla_Force_En able Control from EEPROM.	Yes/No	0h
23:20	EE_Ref_Use_Pad	RO	Device Ref_Use_Pad_Enable Control from EEPROM.	Yes/No	0h
27:24	EE_Ref_Repeat_Clk_En	RO	Device Ref_Repeat_Clk_Enable Control from EEPROM.	Yes/No	0h
28	EE_Phy_Control_En	RO	Device Phy Clock External Control Enable from EEPROM.	Yes/No	0
29	Valid for bit[19:16]	RO	1b: bit[19:16] are valid.	Yes/No	0
30	Valid for bit[23:20]	RO	1b: bit[23:20] are valid.	Yes/No	0
31	Reserved	RsvdP	Not support.	No	0

9.3.190 DEVICE SRIS MODE EXTERNAL CONTROL REGISTER – OFFSET 514h (Port 0 Only)

BIT	FUNCTION	TYPE	DESCRIPTION	EEPROM/ I2C-SMBUS	DEFAULT
0	lane 0_Sris_Mode	RO	Lane 0_Sris_ModeExternal Control from EEPROM.	Yes/No	0
1	lane 1_Sris_Mode	RO	Lane 1_Sris_ModeExternal Control from EEPROM.	Yes/No	0
2	lane 2_Sris_Mode	RO	Lane 2_Sris_ModeExternal Control from EEPROM.	Yes/No	0
3	lane 3_Sris_Mode	RO	Lane 3_Sris_ModeExternal Control from EEPROM.	Yes/No	0
4	lane 4_Sris_Mode	RO	Lane 4_Sris_ModeExternal Control from EEPROM.	Yes/No	0
5	lane 5_Sris_Mode	RO	Lane 5_Sris_ModeExternal Control from EEPROM.	Yes/No	0
6	lane 6_Sris_Mode	RO	Lane 6_Sris_ModeExternal Control from EEPROM.	Yes/No	0
7	lane 7_Sris_Mode	RO	Lane 7_Sris_ModeExternal Control from EEPROM.	Yes/No	0
8	lane 8_Sris_Mode	RO	Lane 8_Sris_ModeExternal Control from EEPROM.	Yes/No	0
9	lane 9_Sris_Mode	RO	Lane 9_Sris_ModeExternal Control from EEPROM.	Yes/No	0
10	lane 10_Sris_Mode	RO	Lane 10_Sris_ModeExternal Control from EEPROM.	Yes/No	0
11	lane 11_Sris_Mode	RO	Lane 11_Sris_ModeExternal Control from EEPROM.	Yes/No	0
12	lane 12_Sris_Mode	RO	Lane 12_Sris_ModeExternal Control from EEPROM.	Yes/No	0
13	lane 13_Sris_Mode	RO	Lane 13_Sris_ModeExternal Control from EEPROM.	Yes/No	0
14	lane 14_Sris_Mode	RO	Lane 14_Sris_ModeExternal Control from EEPROM.	Yes/No	0
15	lane 15_Sris_Mode	RO	Lane 15_Sris_ModeExternal Control from EEPROM.	Yes/No	0
30:16	Reserved	RsvdP	Not support.	No	0-0b
31	Sris External Control En	RO	Device Sris External Control Enble.	Yes/No	0

9.3.191 DEVICE COMM REFCLK MODE EXTERNAL CONTROL REGISTER – OFFSET 518h (Port 0 Only)

BIT	FUNCTION	TYPE	DESCRIPTION	EEPROM/ I2C-SMBUS	DEFAULT
0	lane 0_Cmn_Refclk_Mode	RO	Lane 0_Cmm Refclk ModeExternal Control from EEPROM.	Yes/No	0
1	lane 1_Cmn_Refclk_Mode	RO	Lane 1_Cmm Refclk ModeExternal Control from EEPROM.	Yes/No	0

BIT	FUNCTION	TYPE	DESCRIPTION	EEPROM/ I2C-SMBUS	DEFAULT
2	lane 2_Cmn_Refclk_Mode	RO	Lane 2_Cmm Refclk ModeExternal Control from EEPROM.	Yes/No	0
3	lane 3_Cmn_Refclk_Mode	RO	Lane 3_Cmm Refclk ModeExternal Control from EEPROM.	Yes/No	0
4	lane 4_Cmn_Refclk_Mode	RO	Lane 4_Cmm Refclk ModeExternal Control from EEPROM.	Yes/No	0
5	lane 5_Cmn_Refclk_Mode	RO	Lane 5_Cmm Refclk ModeExternal Control from EEPROM.	Yes/No	0
6	lane 6_Cmn_Refclk_Mode	RO	Lane 6_Cmm Refclk ModeExternal Control from EEPROM.	Yes/No	0
7	lane 7_Cmn_Refclk_Mode	RO	Lane 7_Cmm Refclk ModeExternal Control from EEPROM.	Yes/No	0
8	lane 8_Cmn_Refclk_Mode	RO	Lane 8_Cmm Refclk ModeExternal Control from EEPROM.	Yes/No	0
9	lane 9_Cmn_Refclk_Mode	RO	Lane 9_Cmm Refclk ModeExternal Control from EEPROM.	Yes/No	0
10	lane 10_Cmn_Refclk_Mode	RO	Lane 10_Cmm Refclk ModeExternal Control from EEPROM.	Yes/No	0
11	lane 11_Cmn_Refclk_Mode	RO	Lane 11_Cmm Refclk ModeExternal Control from EEPROM.	Yes/No	0
12	lane 12_Cmn_Refclk_Mode	RO	Lane 12_Cmm Refclk ModeExternal Control from EEPROM.	Yes/No	0
13	lane 13_Cmn_Refclk_Mode	RO	Lane 13_Cmm Refclk ModeExternal Control from EEPROM.	Yes/No	0
14	lane 14_Cmn_Refclk_Mode	RO	Lane 14_Cmm Refclk ModeExternal Control from EEPROM.	Yes/No	0
15	lane 15_Cmn_Refclk_Mode	RO	Lane 15_Cmm Refclk ModeExternal Control from EEPROM.	Yes/No	0
30:16	Rsvd	RsvdP	Not support.	No	0-0b
31	Cmn_Refclk_Mode External Control En	RO	Device Cmm Refclk Mode External Control Enble.	Yes/No	0

9.3.192 MBIST CFG CONTROL REGISTER – OFFSET 51Ch (Port 0 Only)

BIT	FUNCTION	TYPE	DESCRIPTION	EEPROM/ I2C-SMBUS	DEFAULT
0	Cfg_Mbist_En	RW	Used to set Mbist Enable from CFG Control.	Yes	0000h
1	Cfg_Mbist_mode	RW	Used to set Mbist En from Pin or CFG.	Yes	0h
31:2	Cfg_Mbist_done	RO	Used to indicate Mbist test Done.	No	0-0h

9.3.193 MBIST CFG STATUS REGISTER – OFFSET 520h (Port 0 Only)

BIT	FUNCTION	TYPE	DESCRIPTION	EEPROM/ I2C-SMBUS	DEFAULT
29:0	Cfg_Mbist_Error	RO	Used to indicate Mbist error. It can be read from I2C/SMBUS only.	No	0-0h
31:30	Reserved	RsvdP	Not support.	No	00b

9.3.194 NOC BIST CONTROL REGISTER – OFFSET 524h (Port 0 Only)

BIT	FUNCTION	TYPE	DESCRIPTION	EEPROM/ I2C-SMBUS	DEFAULT
0	Noc Bist Enable	RO	Used to enable Noc Bist Test.	Yes/No	0
1	Noc_Bist_Enable_sel	RO	Used to select the NOC Bist Enable Source. 1: Noc Bist Control Register bit[0] 0: Jtag	Yes/No	0
23:2	Reserved	RsvdP	Not support.	No	0-0b
31:24	Noc Bist Status	RO	Noc Bist Status. It can be read from I2C/SMBUS only.	No	00h

9.3.195 EXTERNAL LOOPBACK PRBS CONTROL REGISTER – OFFSET 528h (Port 0 Only)

BIT	FUNCTION	TYPE	DESCRIPTION	EEPROM/ I2C-SMBUS	DEFAULT
1:0	Lane 3-0 PRBS Rate	RW	Choose Lane 3-0 PRBS Rate. 00b: GEN1 01b: GEN2 10b: GEN3 11b: Reserved	Yes	00b
3:2	Lane 7-4 PRBS Rate	RW	Choose Lane 7-4 PRBS Rate. 00b: GEN1 01b: GEN2 10b: GEN3 11b: Reserved	Yes	00b
5:4	Lane 11-8 PRBS Rate	RW	Choose Lane 11-8 PRBS Rate. 00b: GEN1 01b: GEN2 10b: GEN3 11b: Reserved	Yes	00b
7:6	Lane 15-12 PRBS Rate	RW	Choose Lane 15-12 PRBS Rate. 00b: GEN1 01b: GEN2 10b: GEN3 11b: Reserved	Yes	00b
8	Lane 3-0 PRBS Rate Enable	RW	When enabled, Lane 3-0 is set to PRBS rate as indicated in bit[1:0] to run loopback test. Please note an external test fixture must be provided to loopback TX to RX. Also, please follow PRBS Appnote to set TXEQ PRESET value at GEN3 speed through CR interface.	Yes	0
9	Lane 7-4 PRBS Rate Enable	RW	When enabled, Lane 7-4 is set to PRBS rate as indicated in bit[3:2] to run loopback test. Please note an external test fixture must be provided to loopback TX to RX. Also, please follow PRBS Appnote to set TXEQ PRESET value at GEN3 speed through CR interface.	Yes	0
10	Lane 11-8 PRBS Rate Enable	RW	When enabled, Lane 11-8 is set to PRBS rate as indicated in bit[5:4] to run loopback test. Please note an external test fixture must be provided to loopback TX to RX. Also, please follow PRBS Appnote to set TXEQ PRESET value at GEN3 speed through CR interface.	Yes	0
11	Lane 15-12 PRBS Rate Enable	RW	When enabled, Lane 15-12 is set to PRBS rate as indicated in bit[7:6] to run loopback test. Please note an external test fixture must be provided to loopback TX to RX. Also, please follow PRBS Appnote to set TXEQ PRESET value at GEN3 speed through CR interface.	Yes	0
31:12	Reserved	RsvdP	Not support.	No	0000_0h

9.3.196 PHY SRAM PROGRAM 0 REGISTER – OFFSET 52Ch (Port 0 Only)

BIT	FUNCTION	TYPE	DESCRIPTION	EEPROM/ I2C-SMBUS	DEFAULT
15:0	PHY SRAM DATA	RO	PHY SRAM DATA.	Yes/No	0000h
31:16	PHY SRAM OFFSET	RO	PHY SRAM OFFSET.	Yes/No	0000h

9.3.197 PHY SRAM PROGRAM 1 REGISTER – OFFSET 530h (Port 0 Only)

BIT	FUNCTION	TYPE	DESCRIPTION	EEPROM/ I2C-SMBUS	DEFAULT
0	PHY SRAM Program Enable	RO	Start PHY SRAM Program.	Yes/No	0
1	PHY SRAM Program Done	RO	Finish PHY SRAM Program.	Yes/No	0
31:2	Reserved	RsvdP	Not support.	No	0-0b

9.3.198 FAILOVER CONTROL REGISTER – OFFSET 534h (Port 0 Only)

BIT	FUNCTION	TYPE	DESCRIPTION	EEPROM/ I2C-SMBUS	DEFAULT
0	Reserved	RsvdP	Not support.	No	0
1	dis_dn_hotreset	RW	Used to disable up link down, fire down port hot-reset event. 0b: enable 1b: disable	Yes	0
2	En_up_keep_enum	RW	Used to enable up link down, keep up port enum data. 0b: disable 1b: enable	Yes	0
31:3	Reserved	ResvP	Not support.	No	0-0b

9.3.199 THERMAL SENSOR INT MASK AND STATUS REGISTER – OFFSET 538h (Port 0 Only)

BIT	FUNCTION	TYPE	DESCRIPTION	EEPROM/ I2C-SMBUS	DEFAULT
2:0	thermal sensor 2~0 status	RW1C	Thermal sensor 2~0 status.	Yes	000b
15:3	Reserved	RsvdP	Not support.	No	0-0b
18:16	thermal sensor 2~0 interrupt mask	RW	Thermal sensor 2~0 interrupt mask.	Yes	111b
31:19	Reserved	RsvdP	Not support.	No	0-0b
31:7	Reserved	RsvdP	Not support.	No	0-0h

9.3.200 THERMAL SENSOR CONTROL REGISTER – OFFSET 53Ch (Port 0 Only)

BIT	FUNCTION	TYPE	DESCRIPTION	EEPROM/ I2C-SMBUS	DEFAULT
0	Thermal Sensor 0 Status	RO	Used to indicate the temp over the Threshold	No	0b
1	Thermal Sensor 1 Status	RO	Used to indicate the temp over the Threshold	No	0b
2	Thermal Sensor 2 Status	RO	Used to indicate the temp over the Threshold	No	0b
23:3	Reserved	RsvdP	Not support.	No	0_0h
25:24	Thermal Sensor 0 Threshold	RW	Used to set the threshold of chip temperature. 00b:110 01b:120 10b: 130 11b: 140	Yes	0
27:26	Thermal Sensor 1 Threshold	RW	Used to set the threshold of chip temperature. 00b:110 01b:120 10b: 130 11b: 140	Yes	0

BIT	FUNCTION	TYPE	DESCRIPTION	EEPROM/ I2C-SMBUS	DEFAULT
29:28	Thermal Sensor 2 Threshold	RW	Used to set the threshold of chip temperature. 00b: 110 01b: 120 10b: 130 11b: 140	Yes	0
30	Reserved	RsvdP	Not support.	No	0
31	Auto Test Temp.	RW	Used to set Thermal Sensor burst test Enable	Yes	0

9.3.201 DEVICE ELASTIC BUFFER EMPTY MODE EXTERNAL CONTROL REGISTER – OFFSET 540h (Port 0 Only)

BIT	FUNCTION	TYPE	DESCRIPTION	EEPROM/ I2C-SMBUS	DEFAULT
0	lane 0_Eb_Empty_Mode	RO	Lane 0_Eb_Empty_Mode External Control from EEPROM.	Yes/No	0
1	lane 1_Eb_Empty_Mode	RO	Lane 1_Eb_Empty_Mode External Control from EEPROM.	Yes/No	0
2	lane 2_Eb_Empty_Mode	RO	Lane 2_Eb_Empty_Mode External Control from EEPROM.	Yes/No	0
3	lane 3_Eb_Empty_Mode	RO	Lane 3_Eb_Empty_Mode External Control from EEPROM.	Yes/No	0
4	lane 4_Eb_Empty_Mode	RO	Lane 4_Eb_Empty_Mode External Control from EEPROM.	Yes/No	0
5	lane 5_Eb_Empty_Mode	RO	Lane 5_Eb_Empty_Mode External Control from EEPROM.	Yes/No	0
6	lane 6_Eb_Empty_Mode	RO	Lane 6_Eb_Empty_Mode External Control from EEPROM.	Yes/No	0
7	lane 7_Eb_Empty_Mode	RO	Lane 7_Eb_Empty_Mode External Control from EEPROM.	Yes/No	0
8	lane 8_Eb_Empty_Mode	RO	Lane 8_Eb_Empty_Mode External Control from EEPROM.	Yes/No	0
9	lane 9_Eb_Empty_Mode	RO	Lane 9_Eb_Empty_Mode External Control from EEPROM.	Yes/No	0
10	lane 10_Eb_Empty_Mode	RO	Lane 10_Eb_Empty_Mode External Control from EEPROM.	Yes/No	0
11	lane 11_Eb_Empty_Mode	RO	Lane 11_Eb_Empty_Mode External Control from EEPROM.	Yes/No	0
12	lane 12_Eb_Empty_Mode	RO	Lane 12_Eb_Empty_Mode External Control from EEPROM.	Yes/No	0
13	lane 13_Eb_Empty_Mode	RO	Lane 13_Eb_Empty_Mode External Control from EEPROM.	Yes/No	0
14	lane 14_Eb_Empty_Mode	RO	Lane 14_Eb_Empty_Mode External Control from EEPROM.	Yes/No	0
15	lane 15_Eb_Empty_Mode	RO	Lane 15_Eb_Empty_Mode External Control from EEPROM..	Yes/No	0
30:16	Rerved	RsvdP	Not support.	No	0-0b
31	Eb_Empty_Mode External Control En	RO	Device Cmm Refelk Mode External Control Enble.	Yes/No	0

9.3.202 DEVICE MISC REGISTER – OFFSET 544h (Port 0 Only)

BIT	FUNCTION	TYPE	DESCRIPTION	EEPROM/ I2C-SMBUS	DEFAULT
0	HW_Init_Load	RO	When set, it means eeprom preloading is done.	Yes/No	0
31:1	Rerved	RsvdP	Not support.	No	0-0b

9.3.203 SWITCH DOMAIN MODE CONTROL REGISTER – OFFSET 558h (Port 0 Only)

BIT	FUNCTION	TYPE	DESCRIPTION	EEPROM/ I2C-SMBUS	DEFAULT
7:0	Reserved	RsvdP	Not support.	No	04h

BIT	FUNCTION	TYPE	DESCRIPTION	EEPROM/ I2C-SMBUS	DEFAULT
13:8	Broadcast_idx	RW	Used to enable destination switch for broadcast message.	Yes	00_0011b
31:14	Reserved	RsvdP	Not support.	No	0-0h

9.3.204 PORT CLOCK CONTROL REGISTER – OFFSET 55Ch (Port 0 Only)

BIT	FUNCTION	TYPE	DESCRIPTION	EEPROM/ I2C-SMBUS	DEFAULT
0	Reserved	RsvdP	Not support.	No	0b
1	Fix_Bifurcation	RO	Used to fix the bifurcation result according to bit[7:4] or bit[11:8]. For manual bifurcation, both of bit0 and bit1 must be set to “1”.	Yes	0b
7:2	Reserved	RsvdP	Not support.	No	0-0b
11:8	Fix_416_result	RO	port_cfg set to 4444 mode. 0000b: set bifurcation result to 416(4444) 0001b: set bifurcation result to 516A(44422) 0010b: set bifurcation result to 516B(44224) 0011b: set bifurcation result to 516C(42244) 0100b: set bifurcation result to 516D(22444) 0101b: set bifurcation result to 616A(442222) 0110b: set bifurcation result to 616B(422422) 0111b: set bifurcation result to 616C(224422) 1000b: set bifurcation result to 616D(422224) 1001b: set bifurcation result to 616E(224224) 1010b: set bifurcation result to 616F(222244) 1011b: set bifurcation result to 716A(4222222) 1100b: set bifurcation result to 716B(2242222) 1101b: set bifurcation result to 716C(2224222) 1110b: set bifurcation result to 716D(2222224) 1111b: set bifurcation result to 816(2222222)	Yes	0
12	Port0_auto_bifu_En	RO	0b: auto bifurcation for port 0 is disabled 1b: auto bifurcation for port 0 is enabled	Yes	0
13	Port2_auto_bifu_En	RO	0b: auto bifurcation for port 2 is disabled 1b: auto bifurcation for port 2 is enabled	Yes	0
14	Port4_auto_bifu_En	RO	0b: auto bifurcation for port 4 is disabled 1b: auto bifurcation for port 4 is enabled	Yes	0
15	Port6_auto_bifu_En	RO	0b: auto bifurcation for port 6 is disabled 1b: auto bifurcation for port 6 is enabled	Yes	0
16	Port Clock control Enable	RW	Used to enable Port Clock control function.	Yes	0
23:17	Reserved	RsvdP	Not support.	No	0-0h
31:24	Port Clock Enable	RW	Used to set Port0~Port7 Port Clock Enable. These bits are valid when bit[16]=1.	Yes	FFh

9.3.205 PERFORMANCE COUNTER CONTROL REGISTER – OFFSET 56Ch

BIT	FUNCTION	TYPE	DESCRIPTION	EEPROM/ I2C-SMBUS	DEFAULT
0	counter_start_stop	RW	1b: Performance counter start counting 0b: Performance counter stop counting	Yes	0
1	counter_clear	WO	1b: clear performance counter. It is valid when bit[4]=1 and is always read as 0b.	Yes	0
3:2	Reserved	RsvdP	Not support.	No	00b
4	counter_enable	RW	1b: Performance counter is controlled by s/w (bit[0]) 0b: Performance counter is controlled by h/w (autorun)	No	0
31:5	Reserved	RsvdP	Not support.	No	0-0h

9.3.206 PHY SOURCE SELECT REGISTER – OFFSET 570h

BIT	FUNCTION	TYPE	DESCRIPTION	EEPROM/ I2C-SMBUS	DEFAULT
7:0	Lanexx phy_source select	RW	Internal used only.	Yes	00h
8	Valid for bit[7:1]	RW	1b: bit[7:0] are valid	Yes	0
31:9	Reserved	RsvdP	Not support.	No	0-0h

9.3.207 NIC CTRL 0 REGISTER – OFFSET 5A0h (Port 0 Only)

BIT	FUNCTION	TYPE	DESCRIPTION	EEPROM/ I2C-SMBUS	DEFAULT
7:0	Debug Select	RW	Select Debug Nic Signal.	Yes	00h
9:8	Cmd Arbiter Delay	RW	Delay cycles for next cmd arbiter start.	Yes	00b
15:10	Reserved	RW	Internal used only.	Yes	0000_00b
16	Destination Credit Wait	RW	Wait until destination credit is enough to transmit packet. 0b: OFF 1b: ON	Yes	0
17	Reserved	RsvdP	Not support.	No	0
20:18	Time Based RR Time Period	RW	Time Period Selection for Time based Round Robin.	Yes	000b
23:21	Reserved	RW	Internal used only.	No	000b
31:24	Reserved	RsvdP	Not support.	No	00h

9.3.208 NIC CTRL 1 REGISTER – OFFSET 5A4h (Port 0 Only)

BIT	FUNCTION	TYPE	DESCRIPTION	EEPROM/ I2C-SMBUS	DEFAULT
31:0	Reserved	RsvdP	Not support.	No	0000_0000h

9.3.209 NIC CTRL 2 REGISTER – OFFSET 5A8h (Port 0 Only)

BIT	FUNCTION	TYPE	DESCRIPTION	EEPROM/ I2C-SMBUS	DEFAULT
1:0	NIC Router Arbiter Delay	RW	Delay cycles for next arbiter start.	Yes	00b
2	NIC Out Router Arbiter Delay	RW	Delay cycles for next arbiter start.	Yes	1
3	msic	RW	Internal used only.	Yes	0
6:4	noc_buffer_empty for speed up	RW	Internal used only.	Yes	010b
7	nic_speed_up_en	RW	Internal used only.	Yes	0
15:8	Reserved	RsvdP	Not support.	No	00h
18:16	Adaptive Weight RR Period	RW	Time Period Selection for Adaptive Weight Round Robin.	Yes	000b
21:19	Adaptive Weight Ignore Period	RW	Time Period Selection for Reduce Weights of Round Robin.	Yes	000b
22	phase_tag_arbiter_en	RW	Internal used only.	Yes	0
23	Reserved	RsvdP	Not support.	No	0
28:24	phase_tag_timer	RW	Internal used only.	Yes	0_0010b
31:29	Reserved	RsvdP	Not support	No	000b

9.3.210 NIC CTRL 3 REGISTER – OFFSET 5ACh (Port 0 Only)

BIT	FUNCTION	TYPE	DESCRIPTION	EEPROM/ I2C-SMBUS	DEFAULT
31:0	Reserved	RsvdP	Not support.	No	0000_0000h

9.3.211 NIC CTRL 4 REGISTER – OFFSET 5B0h (Port 0 Only)

BIT	FUNCTION	TYPE	DESCRIPTION	EEPROM/ I2C-SMBUS	DEFAULT
31:0	Reserved	RsvdP	Not support.	No	0000_0000h

9.3.212 CR RW CTRL AND STATUS REGISTER – OFFSET 5C0h (Port 0 Only)

BIT	FUNCTION	TYPE	DESCRIPTION	EEPROM/ I2C-SMBUS	DEFAULT
0	Write Enable for Lane 3-0	RW	Write enable bit for Lane 3-0.	No/Yes	0
1	Write Enable for Lane 7-4	RW	Write enable bit for Lane 7-4.	No/Yes	0
2	Write Enable for Lane 11-8	RW	Write enable bit for Lane 11-8.	No/Yes	0
3	Write Enable for Lane 15-12	RW	Write enable bit for Lane 15-12.	No/Yes	0
7:4	Reserved	RsvdP	Not support.	No	0h
8	Read Enable for Lane 3-0	RW	Read enable bit for Lane 3-0.	No/Yes	0
9	Read Enable for Lane 7-4	RW	Read enable bit for Lane 7-4.	No/Yes	0
10	Read Enable for Lane 11-8	RW	Read enable bit for Lane 11-8.	No/Yes	0
11	Read Enable for Lane 15-12	RW	Read enable bit for Lane 15-12.	No/Yes	0
15:12	Reserved	RsvdP	Not support.	No	0h
19:16	RW Ready Status	RO	Indicates whether Lane 3-0, Lane 7-4, Lane 11-8 or Lane 15-12 is ready for the Read or Write cycle.	No	1111h
31:20	Reserved	RsvdP	Not support.	No	000h

9.3.213 CR CTRL 0 REGISTER – OFFSET 5C4h (Port 0 Only)

BIT	FUNCTION	TYPE	DESCRIPTION	EEPROM/ I2C-SMBUS	DEFAULT
15:0	Lane 3-0 Data	RW	Contains the Lane 3-0 register data.	Yes	0000h
31:16	Lane 3-0 Register	RW	Contains the Lane 3-0 register address.	Yes	0000h

9.3.214 CR CTRL 1 REGISTER – OFFSET 5C8h (Port 0 Only)

BIT	FUNCTION	TYPE	DESCRIPTION	EEPROM/ I2C-SMBUS	DEFAULT
15:0	Lane 7-4 Data	RW	Contains the Lane 7-4 register data.	Yes	0000h
31:16	Lane 7-4 Register	RW	Contains the Lane 7-4 register address.	Yes	0000h

9.3.215 CR CTRL 2 REGISTER – OFFSET 5CCh (Port 0 Only)

BIT	FUNCTION	TYPE	DESCRIPTION	EEPROM/ I2C-SMBUS	DEFAULT
15:0	Lane 11-8 Data	RW	Contains the Lane 11-8 register data.	Yes	0000h
31:16	Lane 11-8 Register	RW	Contains the Lane 11-8 register address.	Yes	0000h

9.3.216 CR CTRL 3 REGISTER – OFFSET 5D0h (Port 0 Only)

BIT	FUNCTION	TYPE	DESCRIPTION	EEPROM/ I2C-SMBUS	DEFAULT
15:0	Lane 15-12 Data	RW	Contains the Lane 15-12 register data.	Yes	0000h
31:16	Lane 15-12 Register	RW	Contains the Lane 15-12 register address.	Yes	0000h

9.3.217 THERMAL SENSOR TEST REGISTER – OFFSET 5D4h (Port 0 Only)

BIT	FUNCTION	TYPE	DESCRIPTION	EEPROM/ I2C-SMBUS	DEFAULT
3:0	Thermal Sensor Test Access Control	RW	Select Thermal Sensor Test Items.	Yes	0h
5:4	Thermal Sensor Chip Select	RW	Chip Select for Thermal Sensor Test. 00b: Thermal Sensor 0 01b: Thermal Sensor 1 10b: Thermal Sensor 2 11b: Reserved	Yes	00b
6	Software Digital Test Mode	RW	Digital Test Enable. 0b: Disable 1b: Enable	Yes	0
7	Reserved	RsvdP	Not support.	No	0
8	Digital Test Status	RO	Indicate Success or Fail Status of Digital Test. 0b: Fail 1b: Success	No	0
9	Digital Test Mode 8 Status	RO	Indicate Success or Fail Status of Digital Test Mode 8. 0b: Fail 1b: Success	No	0
10	Digital Test Mode 9 Status	RO	Indicate Success or Fail Status of Digital Test Mode 9. 0b: Fail 1b: Success	No	0
14:11	Reserved	RsvdP	Not support.	No	0h
15	Digital Test Done	RO	Thermal Sensor Digital Test Done Status. 0b: Test no complete 1b: Test complete	No	0
16	EEPROM Single Read	RW	Internal used only.	No	0
31:17	Reserved	RsvdP	Not support.	No	0000h

9.3.218 THERMAL SENSOR CTRL 0 REGISTER – OFFSET 5D8h (Port 0 Only)

BIT	FUNCTION	TYPE	DESCRIPTION	EEPROM/ I2C-SMBUS	DEFAULT
0	Thermal Sensor Burst Run	RW	Get Thermal Result periodically. 0b: OFF 1b: ON	Yes	0
1	Thermal Sensor Single Run	RW	Get Thermal Result Once. 0b: OFF 1b: ON	Yes	0
2	Thermal Sensor Power Down	RW	Trun off Thermal Sensor. 0b: disable power down 1b: enable power down	Yes	0
7:3	Reserved	RsvdP	Not support.	No	0_0b
19:8	Thermal Sensor Conversion Data Output	RO	Thermal Sensor Results.	No	000h
22:20	Reserved	RsvdP	Not support.	No	000b
23	Thermal Sensor Conversion Done	RO	Get Thermal Sensor Result Done. 0b: Conversion not complete 1b: Conversion complete	No	0
31:24	Reserved	RsvdP	Not support.	No	00h

9.3.219 THERMAL SENSOR CTRL 1 REGISTER – OFFSET 5DCh (Port 0 Only)

BIT	FUNCTION	TYPE	DESCRIPTION	EEPROM/ I2C-SMBUS	DEFAULT
0	Thermal Sensor Burst Run	RW	Get Thermal Result periodically. 0b: OFF 1b: ON	Yes	0
1	Thermal Sensor Single Run	RW	Get Thermal Result Once. 0b: OFF 1b: ON	Yes	0
2	Thermal Sensor Power Down	RW	Trun off Thermal Sensor. 0b: disable power down 1b: enable power down	Yes	0
7:3	Reserved	RsvdP	Not support.	No	0_0b
19:8	Thermal Sensor Conversion Data Output	RO	Thermal Sensor Result.	No	000h
22:20	Reserved	RsvdP	Not support.	No	000b
23	Thermal Sensor Conversion Done	RO	Get Thermal Sensor Result Done. 0b: Conversion not complete 1b: Conversion complete	No	0
31:24	Reserved	RsvdP	Not support.	No	00h

9.3.220 THERMAL SENSOR CTRL 2 REGISTER – OFFSET 5E0h (Port 0 Only)

BIT	FUNCTION	TYPE	DESCRIPTION	EEPROM/ I2C-SMBUS	DEFAULT
0	Thermal Sensor Burst Run	RW	Get Thermal Result periodically. 0b: OFF 1b: ON	Yes	0
1	Thermal Sensor Single Run	RW	Get Thermal Result Once. 0b: OFF 1b: ON	Yes	0
2	Thermal Sensor Power Down	RW	Trun off Thermal Sensor. 0b: disable power down 1b: enable power down	Yes	0
7:3	Reserved	RsvdP	Not support.	No	0_0b
19:8	Thermal Sensor Conversion Data Output	RO	Thermal Sensor Result.	No	000h
22:20	Reserved	RsvdP	Not support.	No	000b
23	Thermal Sensor Conversion Done	RO	Get Thermal Sensor Result Done. 0b: Conversion not complete 1b: Conversion complete	No	0
31:24	Reserved	RsvdP	Not support.	No	00h

9.3.221 INGRESS COMPLETION TLP PACKET COUNT[31:0] REGISTER – OFFSET 600h

BIT	FUNCTION	TYPE	DESCRIPTION	EEPROM/ I2C-SMBUS	DEFAULT
31:0	Ingress Completion TLP Packet Count [31:0]	RC	Records received completion TLP packet count[31:0].	No	0000_0000h

9.3.222 INGRESS COMPLETION TLP PACKET COUNT[47:32] REGISTER – OFFSET 604h

BIT	FUNCTION	TYPE	DESCRIPTION	EEPROM/ I2C-SMBUS	DEFAULT
15:0	Ingress Completion TLP Packet Count [47:32]	RC	Records received completion TLP packet count[47:32].	No	0000h
31:16	Reserved	RsvdP	Not support.	No	0000h

9.3.223 INGRESS COMPLETION TLP PAYLOAD BYTE COUNT[31:0] REGISTER – OFFSET 608h

BIT	FUNCTION	TYPE	DESCRIPTION	EEPROM/ I2C-SMBUS	DEFAULT
31:0	Ingress Completion TLP Payload Byte Count Count[31:0]	RC	Records received completion TLP payload byte count[31:0].	No	0000_0000h

9.3.224 INGRESS COMPLETION TLP PAYLOAD BYTE COUNT[47:32] REGISTER – OFFSET 60Ch

BIT	FUNCTION	TYPE	DESCRIPTION	EEPROM/ I2C-SMBUS	DEFAULT
15:0	Ingress Completion TLP Payload Byte Count[47:32]	RC	Records received completion TLP payload byte count[47:32].	No	0000h
31:16	Reserved	RsvdP	Not support.	No	0000h

9.3.225 INGRESS POST TLP PACKET COUNT[31:0] REGISTER – OFFSET 610h

BIT	FUNCTION	TYPE	DESCRIPTION	EEPROM/ I2C-SMBUS	DEFAULT
31:0	Ingress Post TLP Packet Count[31:0]	RC	Records received post TLP packet count[31:0].	No	0000_0000h

9.3.226 INGRESS POST TLP PACKET COUNT[47:32] REGISTER – OFFSET 614h

BIT	FUNCTION	TYPE	DESCRIPTION	EEPROM/ I2C-SMBUS	DEFAULT
15:0	Ingress Post TLP Packet Count[47:32]	RC	Records received post TLP packet count[47:32].	No	0000h
31:16	Reserved	RsvdP	Not support.	No	0000h

9.3.227 INGRESS POST TLP PAYLOAD BYTE COUNT[31:0] REGISTER – OFFSET 618h

BIT	FUNCTION	TYPE	DESCRIPTION	EEPROM/ I2C-SMBUS	DEFAULT
31:0	Ingress Post TLP Payload Byte Count [31:0]	RC	Records received post TLP payload byte count[31:0].	No	0000_0000h

9.3.228 INGRESS POST TLP PAYLOAD BYTE COUNT[47:32] REGISTER – OFFSET 61Ch

BIT	FUNCTION	TYPE	DESCRIPTION	EEPROM/ I2C-SMBUS	DEFAULT
15:0	Ingress Post TLP Payload Byte Count [47:32]	RC	Records received post TLP payload byte count[47:32].	No	0000h
31:16	Reserved	RsvdP	Not support.	No	0000h

9.3.229 INGRESS BAD TLP PACKET COUNT[31:0] REGISTER – OFFSET 620h

BIT	FUNCTION	TYPE	DESCRIPTION	EEPROM/ I2C-SMBUS	DEFAULT
31:0	Ingress Error TLP Payload Byte Count [31:0]	RC	Records received error TLP packet count bit[31:0]. The counter is increased by one as receiving a TLP contaminated with errors that are enabled in Ingress error counter enable register at offset 67Ch	No	0000_0000h

9.3.230 INGRESS NON-POST TLP PACKET COUNT[31:0] REGISTER – OFFSET 628h

BIT	FUNCTION	TYPE	DESCRIPTION	EEPROM/ I2C-SMBUS	DEFAULT
31:0	Ingress Non-Post TLP Packet Count [31:0]	RC	Records received non-post TLP packet count[31:0].	No	0000_0000h

9.3.231 INGRESS NON-POST TLP PACKET COUNT[47:32] REGISTER – OFFSET 62Ch

BIT	FUNCTION	TYPE	DESCRIPTION	EEPROM/ I2C-SMBUS	DEFAULT
15:0	Ingress Non-Post TLP Packet Count [47:32]	RC	Records received non-post TLP packet count[47:32].	No	0000h
31:16	Reserved	RsvdP	Not support.	No	0000h

9.3.232 EGRESS COMPLETION TLP PACKET COUNT[31:0] REGISTER - OFFSET 630h

BIT	FUNCTION	TYPE	DESCRIPTION	EEPROM/ I2C-SMBUS	DEFAULT
31:0	Egress Completion TLP Packet Count [31:0]	RC	Records transmit completion TLP packet count[31:0].	No	0000_0000h

9.3.233 EGRESS COMPLETION TLP PACKET COUNT[47:32] REGISTER – OFFSET 634h

BIT	FUNCTION	TYPE	DESCRIPTION	EEPROM/ I2C-SMBUS	DEFAULT
15:0	Egress Completion TLP Packet Count [47:32]	RC	Records transmit completion TLP packet count[47:32].	No	0000h
31:16	Reserved	RsvdP	Not support.	No	0000h

9.3.234 EGRESS COMPLETION TLP PAYLOAD BYTE COUNT[31:0] REGISTER – OFFSET 638h

BIT	FUNCTION	TYPE	DESCRIPTION	EEPROM/ I2C-SMBUS	DEFAULT
31:0	Egress Completion TLP Payload Byte Count[31:0]	RC	Records transmit completion TLP payload byte count[31:0].	No	0000_0000h

9.3.235 EGRESS COMPLETION TLP PAYLOAD BYTE COUNT[47:32] REGISTER – OFFSET 63Ch

BIT	FUNCTION	TYPE	DESCRIPTION	EEPROM/ I2C-SMBUS	DEFAULT
15:0	Egress Completion TLP Payload Byte Count[47:32]	RC	Records transmit completion TLP payload byte count[47:32].	No	0000h
31:16	Reserved	RsvdP	Not support.	No	0000h

9.3.236 EGRESS POST TLP PACKET COUNT[31:0] REGISTER – OFFSET 640h

BIT	FUNCTION	TYPE	DESCRIPTION	EEPROM/ I2C-SMBUS	DEFAULT
31:0	Egress Post TLP Packet Count[31:0]	RC	Records transmit post TLP packet count[31:0]	No	0000_0000h

9.3.237 EGRESS POST TLP PACKET BYTE COUNT[47:32] REGISTER – OFFSET 644h

BIT	FUNCTION	TYPE	DESCRIPTION	EEPROM/ I2C-SMBUS	DEFAULT
15:0	Egress Post TLP Packet Count[47:32]	RC	Records transmit post TLP packet count[47:32].	No	0000h
31:16	Reserved	RsvdP	Not support.	No	0000h

9.3.238 EGRESS POST TLP PAYLOAD BYTE COUNT[31:0] REGISTER – OFFSET 648h

BIT	FUNCTION	TYPE	DESCRIPTION	EEPROM/ I2C-SMBUS	DEFAULT
31:0	Egress Post TLP Payload Byte Count [31:0]	RC	Records transmit post TLP payload byte count[31:0].	No	0000_0000h

9.3.239 EGRESS POST TLP PAYLOAD BYTE COUNT[47:32] REGISTER – OFFSET 64Ch

BIT	FUNCTION	TYPE	DESCRIPTION	EEPROM/ I2C-SMBUS	DEFAULT
8:0	Egress Post TLP Payload Byte Count [47:32]	RC	Records transmit post TLP payload byte count[47:32].	No	0000h
31:15	Reserved	RsvdP	Not support.	No	0000h

9.3.240 EGRESS ERROR TLP PACKET COUNT[15:0] REGISTER – OFFSET 650h

BIT	FUNCTION	TYPE	DESCRIPTION	EEPROM/ I2C-SMBUS	DEFAULT
15:0	Egress Error TLP Payload Byte Count [15:0]	RC	Records transmit error TLP packet count[15:0]. A switch internal error such as ECC non-correctable error is detected when the packet reaches an egress port.	No	0000h

9.3.241 EGRESS ERROR TLP PAYLOAD BYTE COUNT[47:32] REGISTER – OFFSET 654h

BIT	FUNCTION	TYPE	DESCRIPTION	EEPROM/ I2C-SMBUS	DEFAULT
8:0	Egress Error TLP Payload Byte Count [47:32]	RC	Records transmit error TLP payload byte count[47:32].	No	0000h
31:15	Reserved	RsvdP	Not support.	No	0000h

9.3.242 EGRESS NON-POST TLP PACKET COUNT[31:0] REGISTER – OFFSET 658h

BIT	FUNCTION	TYPE	DESCRIPTION	EEPROM/ I2C-SMBUS	DEFAULT
31:0	Egress Non-Post TLP Packet Count [31:0]	RC	Records transmit non-post TLP packet count[31:0].	No	0000_0000h

9.3.243 EGRESS NON-POST TLP PACKET COUNT[47:32] REGISTER – OFFSET 65Ch

BIT	FUNCTION	TYPE	DESCRIPTION	EEPROM/ I2C-SMBUS	DEFAULT
15:0	Egress Non-Post TLP Packet Count[47:32]	RC	Records transmit non-post TLP packet count bit[47:32].	No	0000h
31:16	Reserved	RsvdP	Not support.	No	0000h

9.3.244 TL/DLL/MAC/PHY ERROR TYPE SEL REGISTER – OFFSET 660h

BIT	FUNCTION	TYPE	DESCRIPTION	EEPROM/ I2C-SMBUS	DEFAULT
7:0	Reg_664h_Sel	RW	bit[1:0]: Reg_664h_Sel_Type 00b... Reg_664h_Sel[7:2] are used as dll_mac_err_sel_0[5:0] 01b... Reg_664h_Sel[7:2] are used as tl_err_sel_0[5:0] 10b... Reg_664h_Sel[7:2] are used as noc_err_sel_0[5:0] 11b...Reserved dll_mac_err_sel_x[5:0] (x=0, 1 or 2): 00h... seq_err 01h... fcfail_retrain 02h... retry_buffer_full 03h... retry_buffer_ecc_one_bit_error 04h... retry_buffer_ecc_two_bit_error 05h... tx_nullify 06h... replay_timer_expired 07h... replay_no_roll_over 08h... retrain_link 09h... nack_seq_err 0Ah... tlp_tx_fifo_length_error (tlp tx protocol error (redundant sof/eof, length error...)) 0Bh... tlp_tx_fifo_abort 0Ch... tlp_tx_header_error	Yes	FEh

BIT	FUNCTION	TYPE	DESCRIPTION	EEPROM/ I2C-SMBUS	DEFAULT
7:0	Reg_664h_Sel	RW	<p>dll_mac_err_sel_x[5:0] (x=0, 1 or 2): 0Dh... tlp tx no EOF error 0Eh... crc16 error 0Fh... crc32 error 10h... nullify crc detect 11h... receive packet abort(tlp_rx_abort = 1) 12h... receive nack 13h... framing error 14h... retrain link 15h... recv_ts_speed_change 16h... recv_hot_reset_bit 17h... recv_disable_link 18h... recv_loopback 19h... recv_dis_screamb 1Ah... recv_comp 1Bh... goto retrain by MAC 1Ch... goto retrain by DUT LTSSM 1Dh... goto retrain by root 1Eh... PHY status error 1Fh~3Eh... reserved 3Fh... wire or errors that corresponding mask bit set to 0 in TL/DLL/MAC/PHY ERROR MASK 0 Register.</p> <p>tl_err_sel_x[5:0] (x=0, 1 or 2): 00h...TL_ERR_STA[0] 01h...TRAIN_ERR_SET 02h...DLLP_ERR_SET 03h...RX_ERR_SET 04h...BAD_TLP_SET 05h...BAD_DLLP_SET 06h...REPLAY_ROLLOVER_SET 07h...REPLAY_TIMEOUT_SET 08h...UR_ERR_SET_all 09h...ECRC_ERR_SET_all 0Ah...MF_TLP_ERR_SET_all 0Bh...RX_OVERFLOW_SET 0Ch...UC_STS_SET_all 0Dh...FC_ERR_SET_all 0Eh...POISON_TLP_SET_all 0Fh... TL_ECC[0] (P/NP/CPLD buffer 1 bit ecc error OR) 10h... TL_ECC[1] (P/NP/CPLD buffer 1 bit ecc error OR) 11h~12h... Reserved 13h...TL_ERR_STA[1] 14h...TL_ERR_STA[2] 15h...TL_ERR_STA[3] 16h~3Eh... Reserved 3Fh...wire or errors that corresponding mask bit set to 0 in TL/DLL/MAC/PHY ERROR MASK 0 Register.</p> <p>noc_err_sel_x[5:0] (x=0, 1 or 2): 00h~01h... r_buffer one/two bit ecc error 02h~03h... v_buffer one/two bit ecc error 04h~05h... l_buffer one/two bit ecc error 06h~07h... d_buffer one/two bit ecc error 08h~09h... dma noc r_buffer one/two bit ecc error 0Ah~0Bh... dma noc v_buffer one/two bit ecc error 0Ch~0Dh... dma noc l_buffer one/two bit ecc error 0Eh~0Fh... dma noc d_buffer one/two bit ecc error 10h~1Dh... reserved 1Eh... eeprom_done 1Fh... strapin_transfer_time_out 20h~3Eh... reserved 3Fh... wire or errors that corresponding mask bit set to 0 in TL/DLL/MAC/PHY ERROR MASK 0 Register.</p>	Yes	FEh

BIT	FUNCTION	TYPE	DESCRIPTION	EEPROM/ I2C-SMBUS	DEFAULT
15:8	Reg_668h_Sel	RW	bit[1:0]: Reg_668h_Sel_Type. 00b... Reg_668h_Sel[15:10] are used as dll_mac_err_sel_1[5:0] 01b... Reg_668h_Sel[15:10] are used as tl_err_sel_1[5:0] 10b... Reg_668h_Sel[15:10] are used as noc_err_sel_1[5:0] 11b...Reserved If Reg_668h_Sel[15:10] = 3Fh, wire or errors that corresponding mask bit set to 0 in TL/DLL/MAC/PHY ERROR MASK 1 Register .	Yes	FDh
23:16	Reg_66Ch_Sel	RW	bit[1:0]: Reg_66Ch_Sel_Type. 00b... Reg_66Ch_Sel[23:18] are used as dll_mac_err_sel_2[5:0] 01b... Reg_66Ch_Sel[23:18] are used as tl_err_sel_2[5:0] 10b... Reg_66Ch_Sel[23:18] are used as noc_err_sel_2[5:0] 11b...Reserved If Reg_66Ch_Sel[23:18] = 3Fh, wire or errors that corresponding mask bit set to 0 in TL/DLL/MAC/PHY ERROR MASK 2 Register .	Yes	FCh
31:24	Reserved	RsvdP	Not support.	No	00h

9.3.245 TL/DLL/MAC/PHY ERROR COUNT 0 REGISTER – OFFSET 664h

BIT	FUNCTION	TYPE	DESCRIPTION	EEPROM/ I2C-SMBUS	DEFAULT
15:0	TL/DLL/MAC/PHY Error Count 0	RW1C	TL/DLL/MAC/PHY Error count 0.	Yes	0000h

9.3.246 TL/DLL/MAC/PHY ERROR COUNT 1 REGISTER – OFFSET 668h

BIT	FUNCTION	TYPE	DESCRIPTION	EEPROM/ I2C-SMBUS	DEFAULT
15:0	TL/DLL/MAC/PHY Error Count 1	RW1C	TL/DLL/MAC/PHY Error count 1.	Yes	0000h

9.3.247 TL/DLL/MAC/PHY ERROR COUNT 2 REGISTER – OFFSET 66Ch

BIT	FUNCTION	TYPE	DESCRIPTION	EEPROM/ I2C-SMBUS	DEFAULT
15:0	TL/DLL/MAC/PHY Error Count 2	RW1C	TL/DLL/MAC/PHY Error count 2.	Yes	0000h

9.3.248 TL/DLL/MAC/PHY ERROR MASK 0 REGISTER – OFFSET 670h

BIT	FUNCTION	TYPE	DESCRIPTION	EEPROM/ I2C-SMBUS	DEFAULT
31:0	Reg_664 Error Mask	RW	For reg_664_sel[7:2]==6'h3f error mask purpose.	Yes	FFF0_0000h

9.3.249 TL/DLL/MAC/PHY ERROR MASK 1 REGISTER – OFFSET 674h

BIT	FUNCTION	TYPE	DESCRIPTION	EEPROM/ I2C-SMBUS	DEFAULT
31:0	Reg_668 Error Mask	RW	For reg_668_sel[7:2]==6'h3f error mask purpose.	Yes	FB3F_C1FF h

9.3.250 TL/DLL/MAC/PHY ERROR MASK 2 REGISTER – OFFSET 678h

BIT	FUNCTION	TYPE	DESCRIPTION	EEPROM/ I2C-SMBUS	DEFAULT
31:0	Reg_66C Error Mask	RW	For reg_66C_sel[7:2]==6'h3f error mask purpose.	Yes	BFFB_389F h

9.3.251 INGRESS ERROR COUNTER ENABLE REGISTER – OFFSET 67Ch

BIT	FUNCTION	TYPE	DESCRIPTION	EEPROM/ I2C-SMBUS	DEFAULT
0	Training Error Enable	RW	When set, the Training Error event is counted in ingress bad TLP packet counter at offset 620H .	Yes	0
1	Reserved	RsvdP	Not support.	No	0
2	MWR Error Enable	RW	When set, the Memory write error event is counted in ingress bad TLP packet counter at offset 620H .	Yes	1
3	MRD Error Enable	RW	When set, the Memory read clpd error event is counted in ingress bad TLP packet counter at offset 620H .	Yes	1
4	Data Link Protocol Error Enable	RW	When set, the Data Link Protocol Error event is counted in ingress bad TLP packet counter at offset 620H .	Yes	0
5	Surprise Down Error Enable	RW	When set, Surprise Down Error event is counted in ingress bad TLP packet counter at offset 620H .	Yes	0
11:6	Reserved	RsvdP	Not support.	Yes	0
12	Poisoned TLP Enable	RW	When set, an event of Poisoned TLP is counted in ingress bad TLP packet counter at offset 620H .	Yes	0
13	Flow Control Protocol Error Enable	RW	When set, the Flow Control Protocol Error event is counted in ingress bad TLP packet counter at offset 620H .	Yes	0
14	Completion Timeout Enable	RW	When set, the Completion Timeout event is counted in ingress bad TLP packet counter at offset 620H .	Yes	0
15	Completer Abort Enable	RW	When set, the Completer Abort event is counted in ingress bad TLP packet counter at offset 620H .	Yes	0
16	Unexpected Completion Enable	RW	When set, the Unexpected Completion event is counted in ingress bad TLP packet counter at offset 620H .	Yes	0
17	Receiver Overflow Enable	RW	When set, the Receiver Overflow event is counted in ingress bad TLP packet counter at offset 620H .	Yes	0
18	Malformed TLP Enable	RW	When set, an event of Malformed TLP is counted in ingress bad TLP packet counter at offset 620H .	Yes	0
19	ECRC Error Enable	RW	When set, an event of ECRC Error is counted in ingress bad TLP packet counter at offset 620H .	Yes	0
20	Unsupported Request Error Enable	RW	When set, the Unsupported Request event is counted in ingress bad TLP packet counter at offset 620H .	Yes	0
21	ACS Violation Enable	RW	When set, the ACS Violation event is counted in ingress bad TLP packet counter at offset 620H .	Yes	0
22	Reserved	RsvdP	Not support.	Yes	0
23	MC Blocked TLP Enable	RW	When set, the MC Blocked TLP event is counted in ingress bad TLP packet counter at offset 620H .	Yes	0
24	AtomicOp Egress Blocked Enable	RW	When set, the AtomicOp Egress Blocked event is counted in ingress bad TLP packet counter at offset 620H .	Yes	0
25	Bad TLP Enable	RW	When set, the event of Bad TLP has been received is counted in ingress bad TLP packet counter at offset 620H .	Yes	0
26	Bad DLLP Enable	RW	When set, the event of Bad DLLP has been received is counted in ingress bad TLP packet counter at offset 620H .	Yes	0
27	REPLAY_NUM Rollover Enable	RW	When set, the REPLAY_NUM Rollover event is counted in ingress bad TLP packet counter at offset 620H .	Yes	0
28	Replay Timer Timeout Enable	RW	When set, the Replay Timer Timeout event is counted in ingress bad TLP packet counter at offset 620H .	Yes	0
29	Advisory Non-Fatal Error Enable	RW	When set, the Advisory Non-Fatal Error event is counted in ingress bad TLP packet counter at offset 620H .	Yes	0
30	One bit ECC Error Enable	RW	When set, the One-bit ECC Error event is counted in ingress bad TLP packet counter at offset 620H .	Yes	0
31	Two bit ECC Error Enable	RW	When set, the Two-bit ECC Error event is counted in ingress bad TLP packet counter at offset 620H .	Yes	1

9.3.252 TRIGGER 1 MASK REGISTER – OFFSET 700h (Port 0 Only)

BIT	FUNCTION	TYPE	DESCRIPTION	EEPROM/ I2C-SMBUS	DEFAULT
31:0	Trigger 1 Mask	RW	1b: enable corresponding offset 708h bits	Yes	0000_0000h

9.3.253 TRIGGER 2 MASK REGISTER – OFFSET 704h (Port 0 Only)

BIT	FUNCTION	TYPE	DESCRIPTION	EEPROM/ I2C-SMBUS	DEFAULT
31:0	Trigger 2 Mask	RW	1b: enable corresponding offset 70Ch bits	Yes	0000_0000h

9.3.254 PATTERN 1 SETTING REGISTER – OFFSET 708h (Port 0 Only)

BIT	FUNCTION	TYPE	DESCRIPTION	EEPROM/ I2C-SMBUS	DEFAULT
31:0	Pattern 1 Setting	RW	Set bit[31:0] pattern to match internal selected debug_out[31:0] by offset 710h .	Yes	0000_0000h

9.3.255 PATTERN 2 SETING REGISTER – OFFSET 70Ch (Port 0 Only)

BIT	FUNCTION	TYPE	DESCRIPTION	EEPROM/ I2C-SMBUS	DEFAULT
31:0	Pattern 2 Setting	RW	Set bit[31:0] pattern to match internal selected debug_out[31:0] by offset 714h .	Yes	0000_0000h

9.3.256 TRIGGER 1 DEBUG_OUT MODE SELECTION REGISTER – OFFSET 710h (Port 0 Only)

BIT	FUNCTION	TYPE	DESCRIPTION	EEPROM/ I2C-SMBUS	DEFAULT
4:0	Mode 1 Setting	RW	Used as debug_out mode_sel[4:0]. When offset 390h .bit[31]=0 (embedded LA) bit[4]=0, used for MAC debug out signals bit[4]=1 and bit[3:0]=0~14 are used for TLP debug out signals bit[4]=1 and bit[3:0]=15 are used for power saving debug signals When offset 390h .bit[31]=1 (LTSSM flow) bit[4] is used to reset read/write counter	Yes	0_0000b
7:5	Reserved	RsvdP	Not support.	No	000b
13:8	Trigger 1 port Selection	RW	Used to set trigger 1 port.	Yes	00_0000b
31:14	Reserved	RsvdP	Not support.	No	0_0h

9.3.257 TRIGGER 2 DEBUG_OUT MODE SELECTION REGISTER – OFFSET 714h (Port 0 Only)

BIT	FUNCTION	TYPE	DESCRIPTION	EEPROM/ I2C-SMBUS	DEFAULT
4:0	Mode 2 Setting	RW	Used as debug_out mode_sel[4:0].	Yes	0_0000b
7:5	Reserved	RsvdP	Not support.	No	000b
13:8	Trigger 2 port selection	RW	Used to set trigger 2 port.	Yes	00_0000b
31:14	Reserved	RsvdP	Not support.	No	0_0h

9.3.258 TRIGGER 1 AND/OR CONDITION SELECTION REGISTER – OFFSET 718h (Port 0 Only)

BIT	FUNCTION	TYPE	DESCRIPTION	EEPROM/ I2C-SMBUS	DEFAULT
0	And/Or Select 1	RW	0b: OR logical for trigger 1 1b: AND logical for trigger 1	Yes	1
31:1	Reserved	RsvdP	Not support.	No	0_0h

9.3.259 TRIGGER 2 AND/OR CONDITION SELECTION REGISTER – OFFSET 71Ch (Port 0 Only)

BIT	FUNCTION	TYPE	DESCRIPTION	EEPROM/ I2C-SMBUS	DEFAULT
0	And/Or Select 2	RW	0b: OR logical for trigger 1 1b: AND logical for trigger 1	Yes	1
31:1	Reserved	RsvdP	Not support.	No	0_0h

9.3.260 TRIGGER SELECT REGISTER – OFFSET 720h (Port 0 Only)

BIT	FUNCTION	TYPE	DESCRIPTION	EEPROM/ I2C-SMBUS	DEFAULT
2:0	Trigger Select	RW	000b: select offset 708h trigger pattern as trigger 001b: select offset 70Ch trigger pattern as trigger 010b: select offset 708h and 70Ch trigger patterns as trigger 011b: select offset 708h or 70Ch trigger pattern as trigger 100b: if offset 708h match then go to offset 70Ch trigger pattern Others: Reserved	Yes	000b
7:3	Reserved	RsvdP	Not support.	No	0000_0b
10:8	External port trigger	RW	Internal used only.	Yes	000b
31:11	Reserved	RsvdP	Not support.	No	0_0h

9.3.261 TRIGGER POSITION SELECT REGISTER – OFFSET 724h (Port 0 Only)

BIT	FUNCTION	TYPE	DESCRIPTION	EEPROM/ I2C-SMBUS	DEFAULT
6:0	Trigger Position Select	RW	Used to select the trigger address, where 00h is from header (0%) and 7Fh is ending (100%).	Yes	20h
31:7	Reserved	RsvdP	Not support.	No	0_0h

9.3.262 TRIGGER COUNTER SETTING REGISTER – OFFSET 72Ch (Port 0 Only)

BIT	FUNCTION	TYPE	DESCRIPTION	EEPROM/ I2C-SMBUS	DEFAULT
3:0	Counter	RW	Used to set trigger amount when trigger achieves the trigger count.	Yes	0h
31:4	Reserved	RsvdP	Not support.	No	0000_000h

9.3.263 TRIGGER START REGISTER – OFFSET 730h (Port 0 Only)

BIT	FUNCTION	TYPE	DESCRIPTION	EEPROM/ I2C-SMBUS	DEFAULT
0	Trigger Start	RW	When set, start the trigger.	Yes	0
1	Debug_to_use_LA_en	RW	When set, enable debug to use LA.	Yes	0
15:2	Reserved	RsvdP	Not support.	No	0-0b
29:16	Cycle Left	RO	Show how many cycles left.	No	3FFFh
31:30	Reserved	RsvdP	Not support.	No	00b

9.3.264 READ WAVEFORM DATA REGISTER – OFFSET 734h (Port 0 Only)

BIT	FUNCTION	TYPE	DESCRIPTION	EEPROM/ I2C-SMBUS	DEFAULT
31:0	Read Waveform Data	RO	Used to output embedded debug memory data. Total 4096 cycles can be read and read out is in sequence from cycle 0. Each offset 734h read command will advance 1 cycle automatically.	No	0000_0000h

9.3.265 SAMPLE RATE SETTING REGISTER – OFFSET 738h (Port 0 Only)

BIT	FUNCTION	TYPE	DESCRIPTION	EEPROM/ I2C-SMBUS	DEFAULT
3:0	Sample Rate Setting	RW	Used to set the embedded LA sampling rate. 0h: 500MHz sampling rate 1h: 250MHz sampling rate 2h: 125MHz sampling rate ...	Yes	0000_0000h
31:4	Reserved	RsvdP	Not support.	No	0-0h

9.3.266 WAVEFORM OUTPUT PORT SELECT REGISTER – OFFSET 73Ch (Port 0 Only)

BIT	FUNCTION	TYPE	DESCRIPTION	EEPROM/ I2C-SMBUS	DEFAULT
5:0	Waveform Output Port Select	RW	Used to select which port's debug_out[31:0] can be dumped into embedded debug memory.	Yes	00_0000b
7:6	Reserved	RsvdP	Not support.	No	00b
12:8	Waveform Output Model_Sel Select	RW	Used to select which model_sel[4:0] debug_out can be dumped into embedded debug memory.	Yes	0-0b
15:13	Reserved	RsvdP	Not support.	No	000b
16	Switch Output Singal Source	RW	When set, it will switch debug_mode GPIO[31:0] output signal source from internal debug_out to debug memory stored debug_out data.	Yes	0
17	Enable User-Defined Mode	RW	When set, it will select internal debug_out port_sel/mode_sel to bit[5:0]/bit[12:8] port_sel/mode_sel value.	Yes	0
18	PORT_GOOD Setting	RW	When set, it will switch PORT_GOOD_L[7:0] output from original link status to internal error status.	Yes	0
31:19	Reserved	RsvdP	Not support.	No	0-0h

9.3.267 WAVEFORM READ EVENT RESET REGISTER – OFFSET 748h (Port 0 Only)

BIT	FUNCTION	TYPE	DESCRIPTION	EEPROM/ I2C-SMBUS	DEFAULT
0	Back to waveform by CFG/I2C/SMBUS	WO	When set, the read point will back to the header of the waveform. Reading returns 0 always.	Yes	0
31:1	Reserved	RsvdP	Not support.	No	0-0h

9.3.268 DUMP MEMORY TO GPIO RATE CONTROL REGISTER – OFFSET 74Ch (Port 0 Only)

BIT	FUNCTION	TYPE	DESCRIPTION	EEPROM/ I2C-SMBUS	DEFAULT
3:0	Dump Waveform to LA Sample Rate Setting	RW	Used to set the debug memory 32 bits data output to GPIO[31:0] rate. 0h: output to GPIO[31:0] as 500MHz clock rate 1h: output to GPIO[31:0] as 250MHz clock rate 2h: output to GPIO[31:0] as 125MHz clock rate ...	Yes	0h
31:4	Reserved	RsvdP	Not support.	No	0-0h

9.3.269 DUMP WAVEFORM START REGISTER – OFFSET 750h (Port 0 Only)

BIT	FUNCTION	TYPE	DESCRIPTION	EEPROM/ I2C-SMBUS	DEFAULT
0	Dump Waveform Start	RW	When set, start to dump waveform to LA.	Yes	0
31:1	Reserved	RsvdP	Not support.	No	0-0h

9.3.270 FREE RUN BUTTON REGISTER – OFFSET 754h (Port 0 Only)

BIT	FUNCTION	TYPE	DESCRIPTION	EEPROM/ I2C-SMBUS	DEFAULT
0	Free Run Button	RW	When set, debug memory will store pre-defined internal debug_out[31:0] data, and output to GPIO[31:0] automatically.	Yes	0
31:1	Reserved	RsvdP	Not support.	No	0-0h

9.4 CDLEP CONFIGURATION REGISTERS

When the port of the Switch is set to operate at the cross-domain end point mode, it is represented by an Other Bridge that implementstype 0 configuration space header. The following table details the allocation of the register fields of the PCI 2.3 compatible type 0 configuration space header.

Please be aware of those registers marked as port 0 only, which are defined for management purpose.

31 – 24	23 – 16	15 – 8	7 – 0	BYTE OFFSET
Device ID		Vendor ID		00h
Primary Status		Command		04h
Class Code		Revision ID		08h
Reserved	Header Type	Primary Latency Timer	Cache Line Size	0Ch
BAR 0				10h
BAR 1				14h
BAR 2				18h
BAR 3				1Ch
BAR 4				20h
BAR 5				24h
Reserved				28h
SSID		SSVID		2Ch
Reserved				30h
Reserved		Capability Pointer to 40h		34h
Reserved				38h
Reserved		Interrupt Pin	Interrupt Line	3Ch
Power Management Capabilities		Next Item Pointer=48h	Capability ID=01h	40h
PM Data	PPB Support Extensions	Power Management Data		44h
Message Control		Next Item Pointer=68h	Capability ID=05h	48h
Message Address				4Ch
Message Upper Address				50h
Reserved		Message Data		54h
MSI Mask				58h
MSI Pending				5Ch
Reserved				60h – 64h
PCI Express Capabilities Register		Next Item Pointer=A4h	Capability ID=10h	68h
Device Capabilities				6Ch
Device Status		Device Control		70h
Link Capabilities				74h
Link Status		Link Control		78h
Slot Capabilities				7Ch
Slot Status		Slot Control		80h
Reserved				84h – 88h
Device Capabilities 2				8Ch
Device Status 2		Device Control 2		90h
Link Capabilities 2				94h
Link Status 2		Link Control 2		98h
Slot Capabilities 2				9Ch
Slot Status 2		Slot Control 2		A0h
Reserved		Next Item Pointer=B0h	SSID/SSVID Capability ID=0Dh	A4h
SSID		SSVID		A8h
Reserved				ACh
MSI-X Control		Next Item Pointer=C8h	MSI-X Capability ID=11h	B0h
MSI-X Table Offset / Table BIR				B4h
MSI-X PBA Offset / PBA BIR				B8h
Reserved				BCh – C4h
Length		Next Item Pointer=00h	Vendor Specific Capability ID=09h	C8h
Reserved				CCh - DCh
BAR 0 Configuration				E0h
BAR 0-1 Configuration				E4h

31 – 24	23 – 16	15 – 8	7 – 0	BYTE OFFSET
	BAR 2 Configuration			E8h
	BAR 2-3 Configuration			ECh
	BAR 4 Configuration			F0h
	BAR 4-5 Configuration			F4h
	Reserved			F8h - FCh

Other than the PCI 2.3 compatible configuration space header, the Switch also implements PCI express extended configuration space header, which includes advanced error reporting, virtual channel, and power budgeting capability registers. The following table details the allocation of the register fields of PCI express extended capability space header. The first extended capability always begins at offset 100h with a PCI Express Enhanced Capability header and the rest of capabilities are located at an offset greater than 0FFh relative to the beginning of PCI compatible configuration space.

31 – 24	23 – 16	15 – 8	7 – 0	BYTE OFFSET
Next Capability Offset=130h	Cap. Version	PCI Express Extended Capability ID=0001h		100h
	Uncorrectable Error Status			104h
	Uncorrectable Error Mask			108h
	Uncorrectable Error Severity			10Ch
	Correctable Error Status			110h
	Correctable Error Mask			114h
	Advanced Error Capabilities and Control			118h
	Header Log Register 0			11Ch
	Header Log Register 1			120h
	Header Log Register 2			124h
	Header Log Register 3			128h
	Reserved			12Ch
Next Capability Offset=1A0h	Cap. Version	PCI Express Extended Capability ID=0002h		130h
	Port VC Capability 1			134h
VC Arbitration Table Offset=4h		Port VC Capability 2		138h
	Port VC Status	Port VC Control		13Ch
Port Arbitration Table Offset=5h		VC Resource Capability Register (0)		140h
	VC Resource Control Register (0)			144h
	VC Resource Status Register (0)	Reserved		148h
	Reserved			14Ch – 19Ch
Next Capability Offset=1B0h	Cap. Version	PCI Express Extended Capability ID=0003h		1A0h
	Serial Number Lower DW			1A4h
	Serial Number Upper DW			1A8h
	Reserved			1ACh
Next Capability Offset=210h	Cap. Version	PCI Express Extended Capability ID=0004h		1B0h
	Reserved		Data Select	1B4h
	Power Budgeting Data			1B8h
	Reserved		Power Budget Capability	1BCh
	Reserved			1C0h - 20Ch
Next Capability Offset=2B0h	Cap. Version	PCI Express Extended Capability ID=0019h		210h
	Link Control 3			214h
	Lane Error Status			218h
	Lane 1 Equalization Control	Lane 0 Equalization Control		21Ch
	Lane 3 Equalization Control	Lane 2 Equalization Control		220h
	Reserved		Reserved	224h
	Reserved		Reserved	228h
	Lane 5 Equalization Control	Lane 4 Equalization Control		22Ch
	Lane 7 Equalization Control	Lane 6 Equalization Control		230h
	Reserved		Reserved	234h
	Reserved		Reserved	238h
	Reserved			23Ch ~ 2ACh

31 – 24	23 – 16	15 – 8	7 – 0	BYTE OFFSET
Next Capability Offset=300h	Cap. Version	PCI Express Extended Capability ID=001Eh		2B0h
L1 PM Substates Capability				2B4h
L1 PM Substates Control 1				2B8h
L1 PM Substates Control 2				2BCh
Reserved				2C0h ~ 2DCh
CDEP Data 2				2E0h
Reserved				2E4h ~ 2FCh
Next Capability Offset=900h	Cap. Version	PCI Express Extended Capability ID=000Bh		300h
Vendor-Specific Length	Revision	Vendor-Specific ID		304h
Reserved				308h
Reserved				30Ch
Debug Control (Port 0 Only)				310h
Debug Data (Port 0 Only)				314h
SMBUS Control and Status (Port 0 Only)				318h
GPIO 0-15 Direction Control (Port 0 Only)				31Ch
GPIO 16-31 Direction Control (Port 0 Only)				320h
GPIO Input De-bounce (Port 0 Only)				324h
GPIO 0-15 Input Data (Port 0 Only)				328h
GPIO 16-31 Input Data (Port 0 Only)				32Ch
GPIO 0-15 Output Data (Port 0 Only)				330h
GPIO 16-31 Output Data (Port 0 Only)				334h
GPIO 0-31 Interrupt Polarity (Port 0 Only)				338h
GPIO 0-31 Interrupt Status (Port 0 Only)				33Ch
GPIO 0-31 Interrupt Mask (Port 0 Only)				340h
Reserved				344h
Operation Mode (Port 0 Only)				348h
Clock Buffer Control (Port 0 Only)				34Ch
Reserved				350h ~ 37Ch
LTSSM CSR 0				380h
LTSSM CSR 1				384h
LTSSM CSR 2				388h
LTSSM CSR 3				38Ch
LTSSM 0				390h
LTSSM 1				394h
LTSSM 2				398h
LTSSM 3				39Ch
LTSSM 4				3A0h
LTSSM 5				3A4h
LTSSM 6				3A8h
LTSSM 7				3ACh
LTSSM 8				3B0h
LTSSM 9				3B4h
LTSSM 10				3B8h
LTSSM 11				3BCh
LTSSM 12				3C0h
LTSSM 13				3C4h
LTSSM 14				3C8h
LTSSM 15				3CCh
Reserved				3D0h ~ 41Ch
DLL CSR 0				420h
DLL CSR 1				424h
DLL CSR 2				428h
DLL CSR 3				42Ch
DLL CSR 4				430h
DLL CSR 5				434h
DLL CSR 6				438h
DLL CSR 7				43Ch
DLL CSR 8				440h
DLL CSR 9				444h
DLL CSR 10				448h
DLL CSR 11				44Ch
DLL CSR 12				450h

31 - 24	23 - 16	15 - 8	7 - 0	BYTE OFFSET
		DLL CSR 13		454h
		DLL CSR 14		458h
		DLL CSR 15		45Ch
		DLL CSR 16		460h
		DLL CSR 17		464h
		DLL CSR 18		468h
		DLL CSR 19		46Ch
		LA Debug		470h
		Reserved		474h ~ 4BCCh
		TL CSR 0		4C0h
		TL CSR 1		4C4h
		TL CSR 2		4C8h
		TL CSR 3 (Port 0 Only)		4CCCh
		TL CSR 4		4D0h
		Reserved		4D4h ~ 500h
		Device Configuration 0 (Port 0 Only)		504h
		Device Configuration 1 (Port 0 Only)		508h
		Device Configuration 2 (Port 0 Only)		50Ch
		Device Clock External Control (Port 0 Only)		510h
		Device SRIS Mode External Control (Port 0 Only)		514h
		Device COMM Refclk Mode External Control (Port 0 Only)		518h
		MBIST CFG Control (Port 0 Only)		51Ch
		MBIST CFG Status (Port 0 Only)		520h
		NOC BIST Control and Status (Port 0 Only)		524h
		External Loopback PRBS Control (Port 0 Only)		528h
		PHY SRAM Program 0 (Port 0 Only)		52Ch
		PHY SRAM Program 1 (Port 0 Only)		530h
		Failover Control Register (Port 0 Only)		534h
		Thermal Sensor INT Mask and Status (Port 0 Only)		538h
		Thermal Sensor Control (Port 0 Only)		53Ch
		Device Elastic Buffer Empty Mode External Control (Port 0 Only)		540h
		Device Misc (Port 0 Only)		544h
		Reserved		548h ~ 554h
		Switch Domain Mode Control (Port 0 Only)		558h
		Clock Buffer Control (Port 0 Only)		55Ch
		Reserved		560h ~ 568h
		Performance Counter Control		56Ch
		PHY Source Select		570h
		Reserved		574h ~ 59Ch
		NIC_CTLR0 (Port 0 Only)		5A0h
		NIC_CTLR1 (Port 0 Only)		5A4h
		NIC_CTLR2 (Port 0 Only)		5A8h
		NIC_CTLR3 (Port 0 Only)		5ACh
		NIC_CTLR4 (Port 0 Only)		5B0h
		Reserved		5B4h ~ 5BCCh
		CR RW Ctrl and Status (Port 0 Only)		5C0h
		CR_CTRL0 (port 0 Only)		5C4h
		CR_CTRL1 (Port 0 Only)		5C8h
		CR_CTRL2 (Port 0 Only)		5CCh
		CR_CTRL3 (port 0 Only)		5D0h
		Thermal Sensor Test (Port 0 Only)		5D4h
		Thermal Sensor Ctrl 0 (Port 0 Only)		5D8h
		Thermal Sensor Ctrl 1 (Port 0 Only)		5DCh
		Thermal Sensor Ctrl 2 (Port 0 Only)		5E0h
		Reserved		5E4h ~ 5FCh
		INGRESS Completion TLP Packet Count[31:0]		600h
Reserved		INGRESS Completion TLP Packet Count[47:32]		604h
		INGRESS Completion TLP Payload Byte Count[31:0]		608h
Reserved		INGRESS Completion TLP Payload Byte Count[47:32]		60Ch
		INGRESS Post TLP Packet Count[31:0]		610h
Reserved		INGRESS Post TLP Packet Count[47:32]		614h
		INGRESS Post TLP Payload Byte Count[31:0]		618h
Reserved		INGRESS Post TLP Payload Byte Count[47:32]		61Ch
		INGRESS Bad TLP Packet Count[31:0]		620h

31 -24	23 - 16	15 - 8	7 -0	BYTE OFFSET
Reserved				624h
INGRESS Non-Post TLP Packet Count[31:0]				628h
Reserved	INGRESS Non-Post TLP Packet Count[47:32]			62Ch
EGRESS Completion TLP Packet Count[31:0]				630h
Reserved	EGRESS Completion TLP Packet Count[47:32]			634h
EGRESS Completion TLP Payload Byte Count[31:0]				638h
Reserved	EGRESS Completion TLP Payload Byte Count[47:32]			63Ch
EGRESS Post TLP Packet Count[31:0]				640h
Reserved	EGRESS Post TLP Packet Count[47:32]			644h
EGRESS Post TLP Payload Byte Count[31:0]				648h
Reserved	EGRESS Post TLP Payload Byte Count[47:32]			64Ch
Reserved	EGRESS Error TLP Packet Count[15:0]			650h
Reserved				654h
EGRESSNon-Post TLP Packet Count[31:0]				658h
Reserved	EGRESS Non-Post TLP Packet Count[47:32]			65Ch
TL/DLL/MAC/PHY Error Type Sel				660h
TL/DLL/MAC/PHY Error Count 0				664h
TL/DLL/MAC/PHY Error Count 1				668h
TL/DLL/MAC/PHY Error Count 2				66Ch
TL/DLL/MAC/PHY Error Mask 0				670h
TL/DLL/MAC/PHY Error Mask1				674h
TL/DLL/MAC/PHY Error Mask 2				678h
Ingress Error Counter Enable				67Ch
Reserved				680h ~ 6FCh
Trigger 1 Mask (Port 0 Only)				700h
Trigger 2 Mask (port 0 Only)				704h
Pattern 1 Setting (Port 0 Only)				708h
Pattern 2 Setting (Port 0 Only)				70Ch
Trigger 1 Mode Setting (Port 0 Only)				710h
Trigger 2 Mode Setting (port 0 Only)				714h
Trigger 1 and/or Condition Selection (Port 0 Only)				718h
Trigger 2 and/or Condition Selection (Port 0 Only)				71Ch
Trigger Select (Port 0 Only)				720h
Trigger Position Select (Port 0 Only)				724h
Reserved				728h
Trigger Counter Setting (Port 0 Only)				72Ch
Trigger Start (Port 0 Only)				730h
Read Waveform Data (Port 0 Only)				734h
Sample Rate Setting (Port 0 Only)				738h
Waveform Output Port Select (Port 0 Only)				73Ch
Reserved				740h
Reserved				744h
Waveform Read Event Reset (Port 0 Only)				748h
Dump Memory to GPIO Rate Control (Port 0 Only)				74Ch
Dump Waveform Start (Port 0 Only)				750h
Free Run Button (Port 0 Only)				754h
Reserved				758h ~ 8FCh
Next Capability Offset=000h	Cap. Version	PCI Express Extended Capability ID=000Bh		900h
Vendor-Specific Length	Revision	Vendor-Specific ID		904h
BTR 0				908h
BTR 1				90Ch
BTR 4				910h
BTR 5				914h
Address LUT Access Address				918h
Address LUT Access Data 0				91Ch
Address LUT Address Data 1				920h
ID/Domain LUT 0 ~ 15				924h ~ 960h
Reserved				964h ~ 990h
Captured Bus ID for Domain 0 to 1				994h
Reserved				998h ~ 9C0h
Door Bell IRQ Set				9C4h
Door Bell IRQ Clear				9C8h
Door Bell IRQ Mask Set				9CCh

31 – 24	23 – 16	15 - 8	7 – 0	BYTE OFFSET
Door Bell IRQ Mask Clear				9D0h
Reserved				9D4h ~ 9E0h
Scratchpad 0 ~ 7				9E4h ~ A00h
CDEP Data 0				A04h
CDEP Data 1				A08h
SQ/CQ Pointer Control and Status				A0Ch
SQ Tail Base Pointer[31:0]				A10h
SQ Tail Base Pointer[63:32]				A14h
CQ Header Location[31:0]				A18h
CQ Header Location[63:32]				A1Ch
Reserved				A20h
Reserved				A24h
Uncorrectable Fatal Error Link Reset				A28h
SYNC. CDVEP Uncorrectable Error Status				A2Ch
Reserved				A30h – A78h
Source ID Look-Up Table				A80h – A9Ch
Reserved				AA0h – FFCh

9.4.1 VENDOR ID REGISTER – OFFSET 00h

BIT	FUNCTION	TYPE	DESCRIPTION	EEPROM/ I2C-SMBUS	DEFAULT
15:0	Vendor ID	RO	Identifies Diodes as the vendor of this device.	Yes	12D8h

9.4.2 DEVICE ID REGISTER – OFFSET 00h

BIT	FUNCTION	TYPE	DESCRIPTION	EEPROM/ I2C-SMBUS	DEFAULT
31:16	Device ID	RO	Identifies this device as the PI7C9X3G816.	Yes	C016h

9.4.3 COMMAND REGISTER – OFFSET 04H

BIT	FUNCTION	TYPE	DESCRIPTION	EEPROM/ I2C-SMBUS	DEFAULT
0	I/O Space Enable	RW	0b: Ignores I/O transactions on the primary interface 1b: Enables responses to I/O transactions on the primary interface	Yes	0
1	Memory Space Enable	RW	0b: Ignores memory transactions on the primary interface 1b: Enables responses to memory transactions on the primary interface	Yes	0
2	Bus Master Enable	RW	0b: Does not initiate memory or I/O transactions on the upstream port and handles asan Unsupported Request (UR) to memory and I/O transactions on the downstream port. For Non-Posted Requests, a completion with UR completion status must be returned 1b: Enables the Switch Port to forward memory and I/O Read/Write transactions in the upstream direction	Yes	0
3	Special Cycle Enable	RsvdP	Not support.	No	0
4	Memory Write And Invalidate Enable	RsvdP	Not support.	No	0
5	VGA Palette Snoop Enable	RsvdP	Not support.	No	0
6	Parity Error Response Enable	RW	0b: Switch may ignore any parity errors that it detects and continue normal operation 1b: Switch must take its normal action when a parity error is detected	Yes	0
7	Wait Cycle Control	RsvdP	Not support.	No	0
8	SERR# enable	RW	0b: Disables the reporting of Non-fatal and Fatal errors detected by the Switch to the Root Complex 1b: Enables the Non-fatal and Fatal error reporting to Root Complex	Yes	0
9	Fast Back-to-Back Enable	RsvdP	Not support.	No	0
10	Interrupt Disable	RW	Controls the ability of a PCI Express device to generate INTx	Yes	0

BIT	FUNCTION	TYPE	DESCRIPTION	EEPROM/ I2C-SMBUS	DEFAULT
			Interrupt Messages. In the Switch, this bit does not affect the forwarding of INTx messages from the downstream ports.		
15:11	Reserved	RsvdP	Not support.	No	0000_0b

9.4.4 PRIMARY STATUS REGISTER – OFFSET 04H

BIT	FUNCTION	TYPE	DESCRIPTION	EEPROM/ I2C-SMBUS	DEFAULT
18:16	Reserved	RsvdP	Not support.	No	000b
19	Interrupt Status	RO	Indicates that an INTx Interrupt Message is pending internally to the device. In the Switch, the forwarding of INTx messages from the downstream device of the Switch port is not reflected in this bit. Must be hardwired to 0.	No	0
20	Capabilities List	RO	Set to 1b to enable support for the capability list (offset 34h is the pointer to the data structure).	Yes/No	1
21	66MHz Capable	RO	Does not apply to PCI Express. Must be hardwired to 0.	No	0
22	Reserved	RsvdP	Not support.	No	0
23	Fast Back-to-Back Capable	RsvdP	Not support.	No	0
24	Master Data Parity Error	RW1C	Set to 1b (by a requester) whenever a Parity error is detected or forwarded on the primary side of the port in a Switch. If the Parity Error Response Enable bit is cleared, this bit is never set.	No/Yes	0
26:25	DEVSEL# timing	RsvdP	Not support.	No	00b
27	Signaled Target Abort	RW1C	This bit is Set when the Secondary Side for Type 1 Configuration Space header Function (for Requests completed by the Type 1 header Function itself) completes a Posted or Non-Posted Request as a Completer Abort error.	No/Yes	0
28	Received Target Abort	RsvdP	Not support.	No	0
29	Received Master Abort	RsvdP	Not support.	No	0
30	Signaled System Error	RW1C	Set to 1b when the Switch sends an ERR_FATAL or ERR_NONFATAL Message, and the SERR Enable bit in the Command register is 1b.	No/Yes	0
31	Detected Parity Error	RW1C	Set to 1b whenever the primary side of the port in a Switch receives a Poisoned TLP.	No/Yes	0

9.4.5 REVISION REGISTER – OFFSET 08H

BIT	FUNCTION	TYPE	DESCRIPTION	EEPROM/ I2C-SMBUS	DEFAULT
7:0	Revision	RO	Indicates revision number of device.	Yes	07h for Port 0 06h for Port 4

9.4.6 CLASS REGISTER – OFFSET 08H

BIT	FUNCTION	TYPE	DESCRIPTION	EEPROM/ I2C-SMBUS	DEFAULT
15:8	Programming Interface	RO	Read as 00h to indicate no programming interfaces have been defined for PCI-to-PCI Bridges.	No	00h
23:16	Sub-Class Code	RO	Read as 80h to indicate device is an Other Bridge.	No	80h
31:24	Base Class Code	RO	Read as 06h to indicate device is a Bridge device.	No	06h

9.4.7 CACHE LINE REGISTER – OFFSET 0Ch

BIT	FUNCTION	TYPE	DESCRIPTION	EEPROM/ I2C-SMBUS	DEFAULT
7:0	Cache Line Size	RW	The cache line size register is set by the system firmware and the	Yes	00h

BIT	FUNCTION	TYPE	DESCRIPTION	EEPROM/ I2C-SMBUS	DEFAULT
			operating system cache line size. This field is implemented by PCI Express devices as a RW field for legacy compatibility, but it has no impact on any PCI Express device functionality.		

9.4.8 PRIMARY LATENCY TIMER REGISTER – OFFSET 0Ch

BIT	FUNCTION	TYPE	DESCRIPTION	EEPROM/ I2C-SMBUS	DEFAULT
15:8	Primary Latency Timer	RsvdP	Not support.	No	00h

9.4.9 HEADER TYPE REGISTER – OFFSET 0Ch

BIT	FUNCTION	TYPE	DESCRIPTION	EEPROM/ I2C-SMBUS	DEFAULT
23:16	Header Type	RO	Read as 00h to indicate that the register layout conforms to Type 0 Configuration header for CDLEP port.	No	00h

9.4.10 BAR 0 REGISTER – OFFSET 10h

BIT	FUNCTION	TYPE	DESCRIPTION	EEPROM/ I2C-SMBUS	DEFAULT
0	Memory Space Indicator	RO	Reset to 0b to indicate Memory Base address.	No	0
2:1	64-bit Addressing	RO	00b: 32-bit addressing 10b: 64-bit addressing Others: Reserved	No	00b
3	Prefetchable	RO	0b: Non-prefetchable 1b: Prefetchable	No	0
18:4	Reserved	RsvdP	Not support.	No	0h
31:19	Base Address 0 [31:19]	RW	Use this Memory base address to map the packet switch registers.	Yes	0-0h

9.4.11 BAR 1 REGISTER – OFFSET 14h

BIT	FUNCTION	TYPE	DESCRIPTION	EEPROM/ I2C-SMBUS	DEFAULT
31:0	Reserved	RO	When the Base Address 0 register is not 64-bit addressing (offset 10h[2:1] is not 10b).	No	0000_0000h
	Base Address 0 [63:32]	RW	When the Base Address 0 register is 64-bit addressing. Base Address 1 is used to provide the upper 32 Address bits when offset 10h[2:1] is set to 10b.	Yes	

9.4.12 BAR 2 REGISTER – OFFSET 18h

BIT	FUNCTION	TYPE	DESCRIPTION	EEPROM/ I2C-SMBUS	DEFAULT
0	Memory Space Indicator	RO	Reset to 0b to indicate it is a Memory BAR.	No	0
2:1	Memory Map Type	RO	00b: support 32-bit Memory Space 10b: support 64-bit Memory Space When 64-bit memory space is supported, the assigned memory address has to be larger than 4GB.	No	00b
3	Prefetchable	RO	0b: Non-prefetchable 1b: Prefetchable	No	0
19:4	Reserved	RsvdP	Not support.	No	0-0h
31:20	Base Address 2 [31:20]	RW	Base Address 2.	Yes	000h

9.4.13 BAR 3 REGISTER – OFFSET 1Ch

BIT	FUNCTION	TYPE	DESCRIPTION	EEPROM/ I2C-SMBUS	DEFAULT
0	Memory Space Indicator	RO	When offset 18h[2:1]=00b , BAR 3 is used as an independent 32-bit BAR. Reset to 0b to indicate it is a Memory BAR.	No	0
	Base Address 2 [32]	RW	When 18h[2:1]=10b , BAR 3 is used as the upper 32 bits of 64-bit BAR 2/3.	Yes	0
2:1	Memory Map Type	RO	When offset 18h[2:1]=00b , BAR 3 is used as an independent 32-bit BAR. 00b: support 32-bit Memory Space 10b: support 64-bit Memory Space	No	00b
	Base Address 2 [34:33]	RW	When offset 18h[2:1]=10b , BAR 3 is used as the upper 32 bits of 64-bit BAR 2/3.	Yes	00b
3	Prefetchable	RO	When offset 18h[2:1]=00b , BAR 3 is used as an independent 32-bit BAR. 0b: Non-prefetchable 1b: Prefetchable	No	0
	Base Address 2 [35]	RW	When offset 18h[2:1]=10b , BAR 3 is used as the upper 32 bits of 64-bit BAR 2/3.	Yes	0
19:4	Reserved	RsvdP	When offset 18h[2:1]=00b , bit[19:4] are reserved.	No	0000_000h
	Base Address 2 [51:36]	RW	When offset 18h[2:1]=10b , BAR 3 is used as the upper 32 bits of 64-bit BAR 2/3.	Yes	0000_000h
31:20	Base Address 3 [31:20]	RW	When offset 18h[2:1]=00b , BAR 3 is used as an independent 32-bit BAR.	No	0000_000h
	Base Address 2 [63:52]	RW	When offset 18h[2:1]=10b , BAR 3 is used as the upper 32 bits of 64-bit BAR 2/3.	Yes	0000_000h

9.4.14 BAR 4 REGISTER – OFFSET 20h

BIT	FUNCTION	TYPE	DESCRIPTION	EEPROM/ I2C-SMBUS	DEFAULT
0	Memory Space Indicator	RO	Reset to 0b to indicate it is a Memory BAR.	No	0
2:1	Memory Map Type	RO	00b: support 32-bit Memory Space 10b: support 64-bit Memory Space When 64-bit memory space is supported, the assigned memory address has to be larger than 4GB.	No	00b
3	Prefetchable	RO	0b: Non-prefetchable 1b: Prefetchable	No	0
19:4	Reserved	RsvdP	Not support.	No	0-0h
31:20	Base Address 4 [31:20]	RW	Base Address 4.	Yes	000h

9.4.15 BAR 5 REGISTER – OFFSET 24h

BIT	FUNCTION	TYPE	DESCRIPTION	EEPROM/ I2C-SMBUS	DEFAULT
0	Memory Space Indicator	RO	When offset 20h[2:1] =00b, BAR 5 is used as an independent 32-bit BAR.	No	0
	Base Address 4 [33]	RW	When offset 20h[2:1] =10b, BAR 5 is used as the upper 32 bits of 64-bit BAR 4/5.	Yes	0
2:1	Memory Map Type	RO	When offset 20h[2:1] =00b, BAR 5 is used as an independent 32-bit BAR. 00b: support 32-bit Memory Space 10b: support 64-bit Memory Space	No	00b
	Base Address 4 [34:33]	RW	When offset 20h[2:1] =10b, BAR 5 is used as the upper 32 bits of 64-bit BAR 4/5.	Yes	00b
3	Prefetchable	RO	When offset 20h[2:1] =00b, BAR 5 is used as an independent 32-bit BAR. 0b: Non-prefetchable 1b: Prefetchable	No	0
	Base Address 4 [35]	RW	When offset 20h[2:1] =10b, BAR 5 is used as the upper 32 bits of 64-bit BAR 4/5.	Yes	0
19:4	Reserved	RsvdP	When offset 20h[2:1] =00b, reserved	No	0000_000h
	Base Address 4 [51:36]	RW	When offset 20h[2:1] =10b, BAR 5 is used as the upper 32 bits of 64-bit BAR 4/5.	Yes	0000_000h
31:20	Base Address 5 [31:20]	RsvdP	When offset 20h[2:1] =00b, BAR 5 is used as an independent 32-bit BAR 4/5	No	0000_000h
	Base Address 4 [63:52]	RW	When offset 20h[2:1] =10b, BAR 5 is used as the upper 32 bits of 64-bit BAR 4/5.	Yes	0000_000h

9.4.16 SSVID REGISTER – OFFSET 2Ch

BIT	FUNCTION	TYPE	DESCRIPTION	EEPROM/ I2C-SMBUS	DEFAULT
15:0	SSVID	RO	Identifies the sub-system vendor id.	Yes	12D8h

9.4.17 SSID REGISTER – OFFSET 2Ch

BIT	FUNCTION	TYPE	DESCRIPTION	EEPROM/ I2C-SMBUS	DEFAULT
31:16	SSID	RO	Identifies the sub-system device id.	Yes	C016h

9.4.18 CAPABILITY POINTER REGISTER – OFFSET 34h

BIT	FUNCTION	TYPE	DESCRIPTION	EEPROM/ I2C-SMBUS	DEFAULT
7:0	Capability Pointer	RO	Point to first PCI capability structure.	Yes	40h

9.4.19 INTERRUPT LINE REGISTER – OFFSET 3Ch

BIT	FUNCTION	TYPE	DESCRIPTION	EEPROM/ I2C-SMBUS	DEFAULT
7:0	Interrupt Line	RW	The interrupt line register communicates interrupt line routing information.	Yes	00h

9.4.20 INTERRUPT PIN REGISTER – OFFSET 3Ch

BIT	FUNCTION	TYPE	DESCRIPTION	EEPROM/ I2C-SMBUS	DEFAULT
15:8	Interrupt Pin	RO	The Switch implements INTA virtual wire interrupt signal.	Yes/No	01h

9.4.21 POWER MANAGEMENT CAPABILITIES REGISTER – OFFSET 40h

BIT	FUNCTION	TYPE	DESCRIPTION	EEPROM/ I2C-SMBUS	DEFAULT
7:0	Enhanced Capabilities ID	RO	Read as 01h to indicate that this is power management capability register.	Yes	01h
15:8	Next Item Pointer	RO	Point to next PCI capability structure.	Yes	48h
18:16	Power Management Revision	RO	Read as 011b to indicate the device is compliant to Revision 1.2 of <i>PCI Power Management Interface Specifications</i> .	No	011b
19	PME# Clock	RO	Does not apply to PCI Express. Must be hardwired to 0.	No	0
20	Reserved	RsvdP	Not support.	No	0
21	Device specific Initialization	RO	Read as 0b to indicate Switch does not have device specific initialization requirements.	Yes	0
24:22	AUX Current	RO	Reset to 000b.	Yes	000b
25	D1 Power State Support	RO	Read as 0b to indicate Switch does Not support the D1 power management state.	Yes	0
26	D2 Power State Support	RO	Read as 0b to indicate Switch does Not support the D2 power management state.	Yes	0
31:27	PME# Support	RO	Read as 19h to indicate Switch supports the forwarding of PME# message in D0, D3 and D4 states.	Yes	C8h

9.4.22 POWER MANAGEMENT DATA REGISTER – OFFSET 44h

BIT	FUNCTION	TYPE	DESCRIPTION	EEPROM/ I2C-SMBUS	DEFAULT
1:0	Power State	RW	Indicates the current power state of the Switch. Writing a value of D0 when the previous state was D3 cause a hot reset without asserting DWRST_L. 00b: D0 state 01b: D1 state 10b: D2 state 11b: D3 hot state	Yes	00b
2	Reserved	RsvdP	Not support.	No	0
3	No_Soft_Reset	RO	When set, this bit indicates that device transitioning from D3hot to D0 does not perform an internal reset. When clear, an internal reset is performed when power state transits from D3hot to D0.	Yes	1
7:4	Reserved	RsvdP	Not support.	No	0h
8	PME# Enable	RW	When asserted, the Switch will generate the PME# message.	Yes	0
12:9	Data Select	RW	Select data registers. RW if offset 4C4h[9]=1 and RO if offset 4C4h[9]=0.	Yes	0h
14:13	Data Scale	RO	Reset to 00b.	No/Yes	00b
15	PME Status	RW1C	Read as 0b as the PME# message is not implemented.	Yes	0

9.4.23 PPB SUPPORT EXTENSIONS REGISTER – OFFSET 44h

BIT	FUNCTION	TYPE	DESCRIPTION	EEPROM/ I2C-SMBUS	DEFAULT
21:16	Reserved	RsvdP	Not support.	No	00h
22	B2_B3 Support for D3 _{HOT}	RsvdP	Not support.	No	0
23	Bus Power / Clock Control Enable	RsvdP	Not support.	No	0

9.4.24 DATA REGISTER– OFFSET 44h

BIT	FUNCTION	TYPE	DESCRIPTION	EEPROM/ I2C-SMBUS	DEFAULT
31:24	Data Register	RO	Data Register.	Yes	00h

9.4.25 MSI CAPABILITIES REGISTER – OFFSET 48h

BIT	FUNCTION	TYPE	DESCRIPTION	EEPROM/ I2C-SMBUS	DEFAULT
7:0	Enhanced Capabilities ID	RO	Read as 05h to indicate that this is message signal interrupt capability register.	No	05h
15:8	Next Item Pointer	RO	Point to next PCI capability structure.	Yes	68h
16	MSI Enable	RW	0b: The function is prohibited from using MSI to request service 1b: The function is permitted to use MSI to request service and is prohibited from using its INTx # pin	Yes	0
19:17	Multiple Message Capable	RO	Indicate the number of requested vectors.	Yes	011b
22:20	Multiple Message Enable	RW	Software writes to this field to indicate the number of allocated vectors (equal to or less than the number of requested vectors.)	Yes	000b
23	64-bit address capable	RO	0b: The function is not capable of generating a 64-bit message address 1b: The function is capable of generating a 64-bit message address	Yes	1b
24	Pre-vector Masking Capable	RO	1b: the function supports MSI pre-vector masking. 0b: the function does Not support MSI pre-vector masking.	Yes	1b
31:25	Reserved	RO	Not support.	No	00h

9.4.26 MESSAGE ADDRESS REGISTER – OFFSET 4Ch

BIT	FUNCTION	TYPE	DESCRIPTION	EEPROM/ I2C-SMBUS	DEFAULT
1:0	Reserved	RsvdP	Not support.	No	00b
31:2	Message Address	RW	If the message enable bit is set, the contents of this register specify the DWORD aligned address for MSI memory write transaction.	Yes	0-0h

9.4.27 MESSAGE UPPER ADDRESS REGISTER – OFFSET 50h

BIT	FUNCTION	TYPE	DESCRIPTION	EEPROM/ I2C-SMBUS	DEFAULT
31:0	Message Upper Address	RW	This register is only effective if the device supports a 64-bit message address is set.	Yes	0000_0000h

9.4.28 MESSAGE DATA REGISTER – OFFSET 54h

BIT	FUNCTION	TYPE	DESCRIPTION	EEPROM/ I2C-SMBUS	DEFAULT
15:0	Message Data	RW	Message data.	Yes	0000h

9.4.29 MESSAGE MASK REGISTER – OFFSET 58h

BIT	FUNCTION	TYPE	DESCRIPTION	EEPROM/ I2C-SMBUS	DEFAULT
0	MSI Mask for Hot Plug	RW	MSI mask for Hot Plug interrupts.	Yes	0
1	MSI Mask for DPC	RW	MSI mask for DPC interrupts.	Yes	0
2	MSI Mask for DMA and GPIO	RW	MSI mask for DMAGPIO interrupts.	Yes	0
3	MSI Mask for CDEP	RW	MSI mask for CDEP interrupts.	Yes	0
4	Reserved	RsvdP	Not support.	No	0
5	MSI Mask for thermal sensor	RW	MSI mask for thermal sensor interrupts.	Yes	0
7:6	Reserved	RW	Not support.	No	00
31:8	Reserved	RsvdP	Not support.	No	0000_000h

9.4.30 MESSAGE PENDING REGISTER – OFFSET 5Ch

BIT	FUNCTION	TYPE	DESCRIPTION	EEPROM/ I2C-SMBUS	DEFAULT
0	MSI Pending for Hot Plug Interrupts	RO	MSI pending status for Hot Plug interrupts.	No	0
1	MSI Pending for DPC Interrupts	RO	MSI pending status for DPC interrupts.	No	0
2	MSI Pending for GPIO Interrupts	RO	MSI pending status for GPIO interrupts.	No	0
3	MSI Pending for CDEP Interrupts	RO	MSI pending status for CDEP interrupts.	No	0
4	Reserved	RsvdP	Not support.	No	0
5	MSI Pending for thermal sensor Interrupts	RO	MSI pending status for thermal sensor interrupts.	No	0
31:6	Reserved	RsvdP	Not support.	No	0000_000h

9.4.31 PCI EXPRESS CAPABILITIES REGISTER – OFFSET 68h

BIT	FUNCTION	TYPE	DESCRIPTION	EEPROM/ I2C-SMBUS	DEFAULT
7:0	Enhanced Capabilities ID	RO	Read as 10h to indicate that this is PCI express enhanced capability register.	No	10h
15:8	Next Item Pointer	RO	Point to next PCI capability structure.	Yes	A4h
19:16	Capability Version	RO	Read as 2h to indicate the device is compliant to Revision .2.0 of <i>PCI Express Base Specifications</i> .	Yes	2h
23:20	Device/Port Type	RO	Indicates the type of PCI Express logical device.	Yes	00h
24	Slot Implemented	RsvdP	Not support.	No	0
29:25	Interrupt Message Number	RO	No MSI messages are generated in the transparent mode.	No	00_000b
31:30	Reserved	RsvdP	Not support.	No	00b

9.4.32 DEVICE CAPABILITIES REGISTER – OFFSET 6Ch

BIT	FUNCTION	TYPE	DESCRIPTION	EEPROM/ I2C-SMBUS	DEFAULT
2:0	Max_Payload_Size Supported	RO	Indicates the maximum payload size that the device can support for TLPs. Each port of the Switch supports 512 bytes max payload size.	Yes/No	010b
4:3	Phantom Functions Supported	RO	Indicates the support for use of unclaimed function numbers as Phantom functions. Read as 00b, since the Switch does not act as a requester.	No	00b
5	Extended Tag Field Supported	RO	Indicates the maximum supported size of Tag field as a Requester. Read as 0, since the Switch does not act as a requester.	No	0
8:6	Endpoint L0s Acceptable Latency	RO	Acceptable total latency that an Endpoint can withstand due to the transition from L0s state to the L0 state. For Switch, the ASPM software would not check this value.	No	111b

BIT	FUNCTION	TYPE	DESCRIPTION	EEPROM/ I2C-SMBUS	DEFAULT
11:9	Endpoint L1 Acceptable Latency	RO	Acceptable total latency that an Endpoint can withstand due to the transition from L1 state to the L0 state. For Switch, the ASPM software would not check this value.	No	111b
14:12	Reserved	RsvdP	Not support.	No	000b
15	Role_Based Error Reporting	RO	When set, indicates that the device implements the functionality originally defined in the Error Reporting ECN.	Yes	1
17:16	Reserved	RsvdP	Not support.	No	00b
25:18	Captured Slot Power Limit Value	RO	In combination with the Slot Power Limit Scale value, specifies the upper limit on power supplied by slot. This value is set by the Set_Slot_Power_Limit message or hardwired to 00h.	No	00h
27:26	Captured Slot Power Limit Scale	RO	Specifies the scale used for the Slot Power Limit Value. This value is set by the Set_Slot_Power_Limit message or hardwired to 00b.	No	00b
31:28	Reserved	RsvdP	Not support.	No	0h

9.4.33 DEVICE CONTROL REGISTER – OFFSET 70h

BIT	FUNCTION	TYPE	DESCRIPTION	EEPROM/ I2C-SMBUS	DEFAULT
0	Correctable Error Reporting Enable	RW	0b: Disable Correctable Error Reporting 1b: Enable Correctable Error Reporting	Yes	0
1	Non-Fatal Error Reporting Enable	RW	0b: Disable Non-Fatal Error Reporting 1b: Enable Non-Fatal Error Reporting	Yes	0
2	Fatal Error Reporting Enable	RW	0b: Disable Fatal Error Reporting 1b: Enable Fatal Error Reporting	Yes	0
3	Unsupported Request Reporting Enable	RW	0b: Disable Unsupported Request Reporting 1b: Enable Unsupported Request Reporting	Yes	0
4	Enable Relaxed Ordering	RsvdP	When set, it permits the device to set the Relaxed Ordering bit in the attribute field of transaction. Since the Switch can not either act as a requester or alter the content of packet it forwards, this bit always returns '0' when read.	No	0
7:5	Max_Payload_Size	RW	This field sets maximum TLP payload size for the device. Permissible values that can be programmed are indicated by the Max_Payload_Size Supported in the Device Capabilities register. Any value exceeding the Max_Payload_Size Supported written to this register results into clamping to the Max_Payload_Size Supported value.	Yes	000b
8	Extended Tag Field Enable	RW	0b: Disable Extended Tag Field 1b: Enable Extended Tag Field	Yes	0
9	Phantom Function Enable	RsvdP	Does not apply to PCI Express Switch. Returns '0' when read.	No	0
10	Auxiliary (AUX) Power PM Enable	RO	When set, indicates that a device is enabled to draw AUX power independent of PME AUX power.	No	0
11	Enable No Snoop	RsvdP	When set, it permits to set the No Snoop bit in the attribute field of transaction. Since the Switch can not either act as a requester or alter the content of packet it forwards, this bit always returns '0' when read.	No	0
14:12	Max_Read_Request_Size	RsvdP	This field sets the maximum Read Request size for the device as a Requester. Since the Switch does not generate read request by itself, these bits are hardwired to 000b.	No	000b
15	Reserved	RsvdP	Not support.	No	0

9.4.34 DEVICE STATUS REGISTER – OFFSET 70h

BIT	FUNCTION	TYPE	DESCRIPTION	EEPROM/ I2C-SMBUS	DEFAULT
16	Correctable Error Detected	RW1C	Asserted when correctable error is detected. Errors are logged in this register regardless of whether error reporting is enabled or not in the Device Control register.	Yes	0

BIT	FUNCTION	TYPE	DESCRIPTION	EEPROM/ I2C-SMBUS	DEFAULT
17	Non-Fatal Error Detected	RW1C	Asserted when non-fatal error is detected. Errors are logged in this register regardless of whether error reporting is enabled or not in the Device Control register.	Yes	0
18	Fatal Error Detected	RW1C	Asserted when fatal error is detected. Errors are logged in this register regardless of whether error reporting is enabled or not in the Device Control register.	Yes	0
19	Unsupported Request Detected	RW1C	Asserted when unsupported request is detected. Errors are logged in this register regardless of whether error reporting is enabled or not in the Device Control register.	Yes	0
20	AUX Power Detected	RO	Asserted when the AUX power is detected by the Switch	No	0
21	Transactions Pending	RO	Each port of Switch does not issue Non-posted Requests on its own behalf, so this bit is hardwired to 0b.	No	0
31:22	Reserved	RsvdP	Not support.	No	0-0h

9.4.35 LINK CAPABILITIES REGISTER – OFFSET 74h

BIT	FUNCTION	TYPE	DESCRIPTION	EEPROM/ I2C-SMBUS	DEFAULT
3:0	Maximum Link Speed	RO	Indicates the maximum speed of the Express link is 8Gb/s, 5Gb/s and 2.5 Gb/s. 0001b: 2.5 Gb/s 0001b: 5.0 Gb/s 0011b: 8.0 Gb/s Others: Reserved	Yes	3h
9:4	Maximum Link Width	RO	Indicates the maximum width of the given PCIe Link. Valid widths are x1, x2 or x4 which are set by PORTCFG[2:0] strap pins. Please refer to Table 5-1 00_0001b: x1 lane width 00_0010b: x2 lane width 00_0100b: x4 lane width	Yes	Set by PORTCFG [2:0]
11:10	Active State Power Management (ASPM) Support	RO	Indicates the level of ASPM supported on the given PCIe Link. Each port of Switch supports L0s and L1 entry.	Yes	10b
14:12	L0s Exit Latency	RO	Indicates the L0s exit latency for the given PCIe Link. The length of time this port requires to complete transition from L0s to L0 is in the range of 256ns to less than 512ns.	Yes	011b
17:15	L1 Exit Latency	RO	Indicates the L1 exit latency for the given PCIe Link. The length of time this port requires to complete transition from L1 to L0 is less than 1us.	Yes	000b
18	Clock Power Management	RO	Indicates that component tolerates the removal of any reference clock via CLKREQ#.	Yes	1
19	Surprise Down Capability Enable	RsvdP	Not support.	No	0
20	Data Link Layer Active Reporting Capable	RO	This bit must be set to 1b if the component supports the optional capability of reporting the DL_Active state of the Data Link Control and Management State Machine.	Yes	0
21	Link BW Notify Cap.	RsvdP	Not support	No	0
22	ASPM Optionality Compliance	RO	Software is permitted to use the value of this bit to help determine whether to enable ASPM or whether to run ASPM compliance tests.	Yes	1
23	Reserved	RsvdP	Not support.	No	0
31:24	Port Number	RO	Indicates the PCIe Port Number for the given PCIe Link.	Yes	90h

9.4.36 LINK CONTROL REGISTER – OFFSET 78h

BIT	FUNCTION	TYPE	DESCRIPTION	EEPROM/ I2C-SMBUS	DEFAULT
1:0	Active State Power Management (ASPM) Control	RW	00b: ASPM is Disabled 01b: L0s Entry Enabled 10b: L1 Entry Enabled 11b: L0s and L1 Entry Enabled Note that the receiver must be capable of entering L0s even when the field is disabled	Yes	00b
2	Reserved	RsvdP	Not support.	No	0
3	Read Completion Boundary (RCB)	RsvdP	Not support.	No	0
4	Link Disable	RW	It disables the link when this bit is set.	Yes	0
5	Retrain Link	RW	It initiates Link Retraining when this bit is set. This bit always returns 0b when read.	Yes	0
6	Common Clock Configuration	RW	0b: The components at both ends of a link are operating with synchronous reference clock 1b: The components at both ends of a link are operating with a distributed common reference clock	Yes	0
7	Extended Synch	RW	When set, it transmits 4096 FTS ordered sets in the L0s state for entering L0 state and transmits 1024 TS1 ordered sets in the L1 state for entering L0 state.	Yes	0
8	Enable Clock Power Management	RW	0b: clock power management is disabled and must hold CLKREQ# low 1b: device is permitted to use CLKREQ# to power manage Link clock	Yes	0
9	HW Autonomous Width Disable	RW	Reset to 0b.	Yes	0
10	Link Bandwidth Management Interrupt Enable	RsvdP	Not support.	No	0
11	Link Autonomous Bandwidth Interrupt Enable	RsvdP	Not support	No	0
15:12	Reserved	RsvdP	Not support.	No	0h

9.4.37 LINK STATUS REGISTER – OFFSET 78h

BIT	FUNCTION	TYPE	DESCRIPTION	EEPROM/ I2C-SMBUS	DEFAULT
19:16	Link Speed	RO	Indicate the negotiated speed of the Express link. 0001b: 2.5 Gb/s 0010b: 5.0 Gb/s 0011b: 8.0 Gb/s Others: Reserved	No	0h
25:20	Negotiated Link Width	RO	Indicates the negotiated width of the given PCIe link. 00_0001b: x1 lane width 00_0010b: x2 lane width 00_0100b: x4 lane width	No	Set by PORTCFG [2:0]
26	Training Error	RO	When set, indicates a Link training error occurred. This bit is cleared by hardware upon successful training of the link to the L0 link state.	No	0
27	Link Training	RO	When set, indicates the link training is in progress. Hardware clears this bit once link training is complete.	No	0
28	Slot Clock Configuration	RO	0b: the Switch uses an independent clock irrespective of the presence of a reference on the connector 1b: the Switch uses the same reference clock that the platform provides on the connector	No	1

BIT	FUNCTION	TYPE	DESCRIPTION	EEPROM/ I2C-SMBUS	DEFAULT
29	Data Link Layer Link Active	RO	Indicates the status of the Data Link Control and Management State Machine. 1b: indicate the DL_Active state 0b: otherwise	No	0
30	Link Bandwidth Management Status	RsvdP	Not support.	No	0
31	Link Autonomous Bandwidth Status	RsvdP	Not support.	No	0

9.4.38 SLOT CAPABILITIES REGISTER – OFFSET 7Ch

BIT	FUNCTION	TYPE	DESCRIPTION	EEPROM/ I2C-SMBUS	DEFAULT
31:0	Reserved	RsvdP	Not support.	No	0000_0000h

9.4.39 SLOT CONTROL REGISTER – OFFSET 80h

BIT	FUNCTION	TYPE	DESCRIPTION	EEPROM/ I2C-SMBUS	DEFAULT
15:0	Reserved	RsvdP	Not support.	No	0000h

9.4.40 SLOT STATUS REGISTER – OFFSET 80h

BIT	FUNCTION	TYPE	DESCRIPTION	EEPROM/ I2C-SMBUS	DEFAULT
31:16	Reserved	RsvdP	Not support.	No	0000h

9.4.41 DEVICE CAPABILITIES REGISTER 2 – OFFSET 8Ch

BIT	FUNCTION	TYPE	DESCRIPTION	EEPROM/ I2C-SMBUS	DEFAULT
4:0	Reserved	RsvdP	Not support.	No	0_0000b
5	ARI Forwarding Supported	RO	0b: ARI forwarding is Not supported 1b: ARI forwarding is supported	Yes/No	0
6	Reserved	RsvdP	Not support.	No	0
10:7	Reserved	RsvdP	Not support.	No	0-0b
11	Reserved	RsvdP	Not support.	No	0
17:12	Reserved	RsvdP	Not support.	No	0-0b
19:18	Reserved	RsvdP	Not support.	No	00b
31:20	Reserved	RsvdP	Not support.	No	000h

9.4.42 DEVICE CONTROL REGISTER 2 – OFFSET 90h

BIT	FUNCTION	TYPE	DESCRIPTION	EEPROM/ I2C-SMBUS	DEFAULT
4:0	Reserved	RsvdP	Not support.	No	0_0000b
5	ARI Forwarding Enable	RW	0b: disable 1b: enable	Yes/No	0
6	Reserved	RsvdP	Not support.	No	0
7	Reserved	RsvdP	Not support.	No	0
9:8	Reserved	RsvdP	Not support.	No	00b
10	Reserved	RsvdP	Not support.	No	0
12:11	Reserved	RsvdP	Not support.	No	00b
14:13	Reserved	RsvdP	Not support.	No	00b
15	Reserved	RsvdP	Not support.	No	0

9.4.43 DEVICE STATUS REGISTER 2 – OFFSET 90h

BIT	FUNCTION	TYPE	DESCRIPTION	EEPROM/ I2C-SMBUS	DEFAULT
31:16	Reserved	RsvdP	Not support.	No	0000h

9.4.44 LINK CAPABILITIES REGISTER 2 – OFFSET 94h

BIT	FUNCTION	TYPE	DESCRIPTION	EEPROM/ I2C-SMBUS	DEFAULT
0	Reserved	RsvdP	Not support.	No	0
7:1	Supported Link Speeds Vector	RO	This field indicates the supported Link speed of the associated Port. bit[0]... 2.5 GT/s bit[1]... 5.0 GT/s bit[2]... 8.0 GT/s bit[6:3]... RsvdP	Yes	0000_111b
8	Crosslink Supported	RO	0b: Crosslink is Not supported 1b: Crosslink is supported	Yes	0
31:9	Reserved	RsvdP	Not support.	No	0-0b

9.4.45 LINK CONTROL REGISTER 2 – OFFSET 98h

BIT	FUNCTION	TYPE	DESCRIPTION	EEPROM/ I2C-SMBUS	DEFAULT
3:0	Target Link Speed	RW	0001b: 2.5GT/s link speed is supported 0010b: 5.0GT/s link speed is supported 0011b: 8.0GT/s link speed is supported Others: reserved.	Yes	3h
4	Enter Compliance	RW	1b: enter compliance	Yes	0
5	HW_AutoSpeed_Dis	RW	When set, this bit disables hardware from changing the link speed for device-specific reasons other than attempting to correct unreliable link operation by reducing link speed.	Yes	0
6	Select_Deemp	RO	Valid for downstream ports only. 0b: Select -3.5db de-emphasis 1b: Select -6.0 db de-emphasis	Yes/No	0
9:7	Tran_Margin	RW	This field controls the value of the non-deemphasized voltage level at the transmitter pins. Valid for upstream port only.	Yes	000b
10	Enter Modify Compliance	RW	When set, the device transmits modified compliance pattern if the LTSSM enters Polling.Compliance substate. Valid for upstream port only.	Yes	0
11	Compliance SOS	RW	When set, the LTSSM is required to send SKP Ordered Sets between sequences when sending the Compliance Pattern or Modified Compliance Pattern.	Yes	0
15:12	Compliance Preset/De-emphasis	RW	This field is intended for debug and compliance testing purpose.	Yes	000b

9.4.46 LINK STATUS REGISTER 2 – OFFSET 98h

BIT	FUNCTION	TYPE	DESCRIPTION	EEPROM/ I2C-SMBUS	DEFAULT
16	Current De-emphasis level	RO	1b: -3.5dB 0b: -6 dB	No	1
17	Equalization Complete	RO	When set to 1b, this bit indicates that the Transmitter Equalization procedure has completed.	No	0
18	Equalization Phase 1 Successful	RO	When set to 1b, this bit indicates that Phase 1 of Transmitter Equalization procedure has successfully completed.	No	0
19	Equalization Phase 2 Successful	RO	When set to 1b, this bit indicates that Phase 2 of Transmitter Equalization procedure has successfully completed.	No	0

BIT	FUNCTION	TYPE	DESCRIPTION	EEPROM/ I2C-SMBUS	DEFAULT
20	Equalization Phase 3 Successful	RO	When set to 1b, this bit indicates that Phase 3 of Transmitter Equalization procedure has successfully completed.	No	0
21	Link Equalization Request	RW1C	This bit is set by hardware to request the Link equalization process to be performed on the link.	Yes/No	0
27:22	Reserved	RsvdP	Not support.	No	0-0b
30:28	Downstream Component Presence	RO	This field indicates the presence and DRS status for the Downstream Component. 000b: Link Down – Presence Not Determined 001b: Link Down – Component Not Present 010b: Link Down – Component Present 011b: Reserved 100b: Link Up – Component Present 101b: Link Up – Component Present and DRS Received 110b: Reserved 111b: Reserved	No	000b
31	DRS Message Received	RW1C	This bit must be set whenever the Port receives a DRS message.	Yes/No	0

9.4.47 SLOT CAPABILITIES REGISTER 2 – OFFSET 9Ch

BIT	FUNCTION	TYPE	DESCRIPTION	EEPROM/ I2C-SMBUS	DEFAULT
31:0	Reserved	RsvdP	Not support.	No	0000_0000h

9.4.48 SLOT CONTROL REGISTER 2 – OFFSET A0h

BIT	FUNCTION	TYPE	DESCRIPTION	EEPROM/ I2C-SMBUS	DEFAULT
15:0	Reserved	RsvdP	Not support.	No	0000_0000h

9.4.49 SLOT STATUS REGISTER 2 – OFFSET A0h

BIT	FUNCTION	TYPE	DESCRIPTION	EEPROM/ I2C-SMBUS	DEFAULT
31:16	Reserved	RsvdP	Not support.	No	0000_0000h

9.4.50 SSID/SSVID CAPATILITIES REGISTER – OFFSET A4h

BIT	FUNCTION	TYPE	DESCRIPTION	EEPROM/ I2C-SMBUS	DEFAULT
7:0	SSID/SSVID Capabilities ID	RO	Read as 0Dh to indicate that this is SSID/SSVID capability register.	Yes	0Dh
15:8	Next Item Pointer	RO	Point to next PCI capability structure.	Yes	B0h
31:16	Reserved	RsvdP	Not support.	No	0000h

9.4.51 SUBSYSTEM VENDOR ID REGISTER – OFFSET A8h

BIT	FUNCTION	TYPE	DESCRIPTION	EEPROM/ I2C-SMBUS	DEFAULT
15:0	SSVID	RO	It indicates the sub-system vendor id.	Yes	12D8h

9.4.52 SUBSYSTEM ID REGISTER – OFFSET A8h

BIT	FUNCTION	TYPE	DESCRIPTION	EEPROM/ I2C-SMBUS	DEFAULT
31:16	SSID	RO	It indicates the sub-system device id.	Yes	C016h

9.4.53 MSI-X CAPABILITIES REGISTER – OFFSET B0h

BIT	FUNCTION	TYPE	DESCRIPTION	EEPROM/ I2C-SMBUS	DEFAULT
7:0	MSI-X Capabilities ID	RO	Read as 11h to indicate that this is MSI-X capability register.	No	11h
15:8	Next Item Pointer	RO	Indicates next capability pointer.	Yes	C8h
26:16	Table Size	RO	System software reads this field to determine the MSI-X Table Size N, which is encoded as N-1.	No	005h
29:27	Reserved	RsvdP	Not support.	No	000b
30	Function Mask	RW	If set, all of the vectors associated with the function are masked, regardless of their per-vector mask bit values. If clear, each vector's mask bit determines whether the vector is masked or not.	Yes	0
31	MSI-X Enable	RW	If set and the MSI Enable bit in the MSI Message Control register is clear, the function is permitted to use MSI-X to request service and is prohibited from using INTx interrupts (if implemented). If clear, the function is prohibited from using MSI-X to request service.	Yes	0

9.4.54 MSI-X TABLE OFFSET / TABLE BIR REGISTER – OFFSET B4h

BIT	FUNCTION	TYPE	DESCRIPTION	EEPROM/ I2C-SMBUS	DEFAULT
2:0	Table BIR	RO	Read as 000b to indicate Base Address 0 register (offset 10h in Configuration Space) is used to map the function MSI-X Table into Memory space.	Yes	000b
31:3	Table Offset	RO	Used as an offset from the address contained by one of the function's Base Address registers to point to the base of the MSI-X Table.	Yes	0000_FE00h

9.4.55 MSI-X PBA OFFSET / PBA BIR REGISTER – OFFSET B8h

BIT	FUNCTION	TYPE	DESCRIPTION	EEPROM/ I2C-SMBUS	DEFAULT
2:0	PBA BIR	RO	Read as 000b to indicate Base Address 0 register (offset 10h in Configuration Space) is used to map the function MSI-X PBA into Memory space.	Yes	000b
31:3	PBA Offset	RO	Used as an offset from the address contained by one of the function's Base Address registers to point to the base of the MSI-X PBA.	Yes	0000_FE10h

9.4.56 VENDOR SPECIFIC CAPABILITIES REGISTER – OFFSET C8h

BIT	FUNCTION	TYPE	DESCRIPTION	EEPROM/ I2C-SMBUS	DEFAULT
7:0	Enhanced Capabilities ID	RO	Read as 09h to indicate that these are vendor specific capability registers.	No	09h
15:8	Next Item Pointer	RO	Read as 00h. No other ECP registers.	No	00h
31:16	Length Information	RO	The length field provides the information for number of bytes in the capability structure.	No	0038h

9.4.57 BAR 0 CONFIGURATION REGISTER – OFFSET E0h

BIT	FUNCTION	TYPE	DESCRIPTION	EEPROM/ I2C-SMBUS	DEFAULT
0	Type Selector	RsvdP	Not supported.	No	0
2:1	BAR 0 Type	RW	00b: BAR0 is implemented as a 32 bit Memory BAR 10b: BAR0/1 is implemented as a 64-bit Memory BAR	Yes	00b
3	Prefetchable	RW	0b: Non Prefetchable 1b: Prefetchable	Yes	0
18:4	Reserved	RsvdP	Not supported.	No	0-0b

BIT	FUNCTION	TYPE	DESCRIPTION	EEPROM/ I2C-SMBUS	DEFAULT
30:19	BAR 0 Size	RW	To specify BAR0 size. 0b: Corresponding BAR0 bits are RO bits that always return 0 1b: Corresponding BAR0 bits are RW bits	Yes	FFFh
31	BAR 0 Enable	RW	bit[2:1]=00b 0b: Disable BAR0 1b: Enable BAR0	Yes	1
	BAR 0 Size	RW	bit[2:1]=10b Includes with bit[30:19] when this BAR is used as a 64-bit BAR (bit[2:1]=10b).		

9.4.58 BAR 0-1 CONFIGURATION REGISTER – OFFSET E4h

BIT	FUNCTION	TYPE	DESCRIPTION	EEPROM/ I2C-SMBUS	DEFAULT
0	Type Selector	RsvdP	E0h[2:1]=00b Not support.	No	0
		RW	E0h[2:1]=10b BAR0/1 are used as a 64-bit BAR, bit[31:0] are used as the upper 32-bits.	Yes	0
2:1	BAR 1 Type	RO	E0h[2:1]=00b 00b: BAR1 is implemented as 32 bit Memory BAR.	Yes	00b
		RW	E0h[2:1]=10b BAR0/1 are used as a 64-bit BAR, bit[31:0] are used as the upper 32-bits.	Yes	00b
3	Prefetchable	RW	E0h[2:1]=00b 0b: Non Prefetchable 1b: Prefetchable	Yes	0
		RW	E0h[2:1]=10b BAR0/1 are used as a 64-bit BAR, bit[31:0] are used as the upper 32-bits.		
4	Reserved	RsvdP	E0h[2:1]=00b Not support.	No	0
		RW	E0h[2:1]=10b BAR0/1 are used as a 64-bit BAR, bit[31:0] are used as the upper 32-bits.	Yes	0
8:5	Switch ID	RW	E0h[2:1]=00b The valid number is from 0 to 5.	Yes	0000b
		RW	E0h[2:1]=10b BAR0/1 are used as a 64-bit BAR, bit[31:0] are used as the upper 32-bits.		
19:9	Reserved	RsvdP	E0h[2:1]=00b Not support.	No	0-0b
		RW	E0h[2:1]=10b BAR0/1 are used as a 64-bit BAR, bit[31:0] are used as the upper 32-bits.	Yes	0-0b
30:20	BAR 1 Size	RW	To specify BAR1 size. 0b: Corresponding BAR1 bits are RO bits that always return 0 1b: Corresponding BAR1 bits are RW bits	Yes	000h
31	BAR 1 Enable	RW	E0h[2:1]=00b 0b: Disable BAR1 1b: Enable BAR1	Yes	0
	64-Bit BAR	RW	E0h[2:1]=10b 0b: BAR0/1 is disabled; all BAR0/1 bits read 0. 1b: BAR0/1 is enabled as a 64-bit BAR.		

9.4.59 BAR 2 CONFIGURATION REGISTER – OFFSET E8h

BIT	FUNCTION	TYPE	DESCRIPTION	EEPROM/ I2C-SMBUS	DEFAULT
0	Type Selector	RsvdP	Not supported.	No	0
2:1	BAR2 Type	RW	00b: BAR2 is implemented as a 32 bit Memory BAR 10b: BAR2/3 is implemented as a 64-bit Memory BAR	Yes	00b
3	Prefetchable	RW	0b: Non Prefetchable 1b: Prefetchable	Yes	0
4	LUT/DAT Selection	RW	0b: BAR2/3 is used for Address Look-up Translation. 1b: BAR2/3 is used for Direct Address Translation.	Yes	0
8:5	Domain ID	RW	The valid number is from 0 to 11.	Yes	0000b
19:9	Reserved	RsvdP	Not supported.	No	0-0b

BIT	FUNCTION	TYPE	DESCRIPTION	EEPROM/ I2C-SMBUS	DEFAULT
30:20	BAR2 Size	RW	To specify BAR2 size. 0b: Corresponding BAR2 bits are RO bits that always return 0 1b: Corresponding BAR2 bits are RW bits It implies the minimum window size is 1MB and minimum page size is 8KB, which is windows size divided by 128 (number of LUT entries).	Yes	7FFh
31	BAR 2 Enable	RW	bit[2:1]=00b	Yes	1
	BAR 2 Size	RW	bit[2:1]=10b		
			0b: Disable BAR2 1b: Enable BAR2		
			Includes with bit[30:20] when this BAR is used as a 64-bit BAR (bit[2:1]=10b).		

9.4.60 BAR 2-3 CONFIGURATION REGISTER – OFFSET ECh

BIT	FUNCTION	TYPE	DESCRIPTION	EEPROM/ I2C-SMBUS	DEFAULT	
0	Type Selector	RsvdP	E8h[2:1]=00b	Not support.	No	0
		RW	E8h[2:1]=10b	BAR2/3 are used as a 64-bit BAR, bit[31:0] are used as the upper 32-bits.	Yes	0
2:1	BAR3 Type	RO	E8h[2:1]=00b	00b: BAR3 is implemented as 32 bit Memory BAR.	No	00b
		RW	E8h[2:1]=10b	BAR2/3 are used as a 64-bit BAR, bit[31:0] are used as the upper 32-bits.	Yes/No	00b
3	Prefetchable	RW	E8h[2:1]=00b	0b: Non Prefetchable 1b: Prefetchable	Yes	0
		RW	E8h[2:1]=10b	BAR2/3 are used as a 64-bit BAR, bit[31:0] are used as the upper 32-bits.		
4	Reserved	RsvdP	E8h[2:1]=00b	Not support.	No	0
		RW	E8h[2:1]=10b	BAR2/3 are used as a 64-bit BAR, bit[31:0] are used as the upper 32-bits.	Yes	0
8:5	Domain ID	RW	E8h[2:1]=00b	The valid number is from 0 to 11.	Yes	0000b
		RW	E8h[2:1]=10b	BAR2/3 are used as a 64-bit BAR, bit[31:0] are used as the upper 32-bits.		
19:9	Reserved	RsvdP	E8h[2:1]=00b	Not support.	No	0-0b
		RW	E8h[2:1]=10b	BAR2/3 are used as a 64-bit BAR, bit[31:0] are used as the upper 32-bits.	Yes	0-0b
30:20	BAR3 Size	RW	To specify BAR3 size. 0b: Corresponding BAR3 bits are RO bits that always return 0 1b: Corresponding BAR3 bits are RW bits	Yes	000h	
31	BAR 3 Enable	RW	E8h[2:1]=00b	Yes	0	
	64-Bit BAR	RW	E8h[2:1]=10b			
			0b: Disable BAR3 1b: Enable BAR3			
			0b: BAR2/3 is disabled; all BAR2/3 bits read 0. 1b: BAR2/3 is enabled as a 64-bit BAR.			

9.4.61 BAR 4 CONFIGURATION REGISTER – OFFSET F0h

BIT	FUNCTION	TYPE	DESCRIPTION	EEPROM/ I2C-SMBUS	DEFAULT
0	Type Selector	RsvdP	Not supported.	No	0
2:1	BAR4 Type	RW	00b: BAR4 is implemented as a 32 bit Memory BAR 10b: BAR4/5 is implemented as a 64-bit Memory BAR	Yes	00b
3	Prefetchable	RW	0b: Non Prefetchable 1b: Prefetchable	Yes	0
4	Reserved	RsvdP	Not support.	No	0
8:5	Partition ID	RW	The valid number is from 0 to 11.	Yes	0000b
19:9	Reserved	RsvdP	Not supported.	No	0-0b

BIT	FUNCTION	TYPE	DESCRIPTION	EEPROM/ I2C-SMBUS	DEFAULT
30:20	BAR 4 Size	RW	To specify BAR4 size. 0b: Corresponding BAR4 bits are RO bits that always return 0 1b: Corresponding BAR4 bits are RW bits It implies the minimum window size is 1MB and minimum page size is 8KB, which is windows size divided by 128 (number of LUT entries).	Yes	7FFh
31	BAR 4 Enable	RW	bit[2:1]=00b	Yes	1
	BAR 4 Size	RW	bit[2:1]=10b		
			0b: Disable BAR4 1b: Enable BAR4		
			Includes with bit[30:20] when this BAR is used as a 64-bit BAR (bit[2:1]=10b).		

9.4.62 BAR 4-5 CONFIGURATION REGISTER – OFFSET F4h

BIT	FUNCTION	TYPE	DESCRIPTION	EEPROM/ I2C-SMBUS	DEFAULT	
0	Type Selector	RsvdP	F0h[2:1]=00b	Not support.	No	0
		RW	F0h[2:1]=10b	BAR4/5 are used as a 64-bit BAR, bit[31:0]are used as the upper 32-bits.	Yes	0
2:1	BAR 5 Type	RO	F0h[2:1]=00b	00b: BAR5 is implemented as 32 bit Memory BAR.	Yes	00b
		RW	F0h[2:1]=10b	BAR4/5 are used as a 64-bit BAR, bit[31:0]are used as the upper 32-bits.	Yes	00b
3	Prefetchable	RW	F0h[2:1]=00b	0b: Non Prefetchable 1b: Prefetchable	Yes	0
		RW	F0h[2:1]=10b	BAR4/5 are used as a 64-bit BAR, bit[31:0]are used as the upper 32-bits.		
4	Reserved	RsvdP	F0h[2:1]=00b	Not support.	No	0
		RW	F0h[2:1]=10b	BAR4/5 are used as a 64-bit BAR, bit[31:0] are used as the upper 32-bits.	Yes	0
8:5	Domain/Switch ID	RW	F0h[2:1]=00b	The valid domain number is from 0 to 3.	Yes	0000b
		RW	F0h[2:1]=10b	BAR4/5 are used as a 64-bit BAR, bit[31:0] are used as the upper 32-bits.		
19:9	Reserved	RsvdP	F0h[2:1]=00b	Not support.	No	0-0b
		RW	F0h[2:1]=10b	BAR4/5 are used as a 64-bit BAR, bit[31:0]are used as the upper 32-bits.	Yes	0-0b
30:20	BAR 5 Size	RW	To specify BAR5 size. 0b: Corresponding BA5 bits are RO bits that always return 0 1b: Corresponding BAR5 bits are RW bits	Yes	000h	
31	BAR 5 Enable	RW	F0h[2:1]=00b	Yes	0	
	64-Bit BAR	RW	F0h[2:1]=10b			
			0b: Disable BAR5 1b: Enable BAR5			
			0b: BAR4/5 is disabled; all BAR4/5 bits read 0. 1b: BAR4/5 is enabled as a 64-bit BAR.			

9.4.63 PCI EXPRESS ADVANCED ERROR REPORTING ENHANCED CAPABILITY HEADER REGISTER – OFFSET 100h

BIT	FUNCTION	TYPE	DESCRIPTION	EEPROM/ I2C-SMBUS	DEFAULT
15:0	Extended Capabilities ID	RO	Read as 0001h to indicate that this is PCI express extended capability register for advance error reporting.	No	0001h
19:16	Capability Version	RO	Read as 1h.	No	1h
31:20	Next Capability Offset	RO	Point to next PCI extended capability structure.	Yes	130h

9.4.64 UNCORRECTABLE ERROR STATUS REGISTER – OFFSET 104h

BIT	FUNCTION	TYPE	DESCRIPTION	EEPROM/ I2C-SMBUS	DEFAULT
0	Training Error Status	RW1C	When set, indicates that the Training Error event has occurred.	Yes	0
3:1	Reserved	RsvdP	Not support.	No	000
4	Data Link Protocol Error Status	RW1C	When set, indicates that the Data Link Protocol Error event has occurred.	Yes	0
5	Surprise Down Error Status	RW1C	When set, indicates that the Surprise Down Error event has occurred.	Yes	0
11:6	Reserved	RsvdP	Not support.	No	0-0b
12	Poisoned TLP Status	RW1C	When set, indicates that a Poisoned TLP has been received or generated.	Yes	0
13	Flow Control Protocol Error Status	RW1C	When set, indicates that the Flow Control Protocol Error event has occurred.	Yes	0
14	Completion Timeout Status	RW1C	When set, indicates that the Completion Timeout event has occurred.	Yes	0
15	Completer AbortStatus	RW1C	When set, indicates that the Completer Abort event has occurred.	Yes	0
16	Unexpected Completion Status	RW1C	When set, indicates that the Unexpected Completion event has occurred.	Yes	0
17	Receiver Overflow Status	RW1C	When set, indicates that the Receiver Overflow event has occurred.	Yes	0
18	Malformed TLP Status	RW1C	When set, indicates that a Malformed TLP has been received.	Yes	0
19	ECRC Error Status	RW1C	When set, indicates that an ECRC Error has been detected.	Yes	0
20	Unsupported Request Error Status	RW1C	When set, indicates that an Unsupported Request event has occurred.	Yes	0
21	ACS Violation Status	RW1C	When set, indicates that an ACS Violation event has occurred	Yes	0
22	Internal Error Status	RW1C	When set, indicates that an Internal Error has occurred.	Yes	0
23	MC Blocked TLP Status	RW1C	When set, indicates that an MC Blocked TLP event has occurred.	Yes	0
24	AtomicOp Egress Blocked Status	RW1C	When set, indicates that an AtomicOp Egress Blocked event has occurred.	Yes	0
31:25	Reserved	RsvdP	Not support.	No	0000_000b

9.4.65 UNCORRECTABLE ERROR MASK REGISTER – OFFSET 108h

BIT	FUNCTION	TYPE	DESCRIPTION	EEPROM/ I2C-SMBUS	DEFAULT
0	Training Error Mask	RW	When set, the Training Error event is not logged in the Header Log register and not issued as an Error Message to RC either.	Yes	0
3:1	Reserved	RsvdP	Not support.	No	000b
4	Data Link Protocol Error Mask	RW	When set, the Data Link Protocol Error event is not logged in the Header Log register and not issued as an Error Message to RC either.	Yes	0
5	Surprise Down Error Mask	RW	When set, Surprise Down Error event is not logged in the Header Log register and not issued as an Error Message to RC either.	Yes	0
11:6	Reserved	RsvdP	Not support.	No	0-0b
12	Poisoned TLP Mask	RW	When set, an event of Poisoned TLP has been received or generated is not logged in the Header Log register and not issued as an Error Message to RC either.	Yes	0
13	Flow Control Protocol Error Mask	RW	When set, the Flow Control Protocol Error event is not logged in the Header Log register and not issued as an Error Message to RC either.	Yes	0
14	Completion Timeout Mask	RW	When set, the Completion Timeout event is not logged in the Header Log register and not issued as an Error Message to RC either.	Yes	0
15	Completer AbortMask	RW	When set, the Completer Abort event is not logged in the Header Log register and not issued as an Error Message to RC either.	Yes	0
16	Unexpected Completion Mask	RW	When set, the Unexpected Completion event is not logged in the Header Log register and not issued as an Error Message to RC either.	Yes	0
17	Receiver Overflow Mask	RW	When set, the Receiver Overflow event is not logged in the Header Log register and not issued as an Error Message to RC either.	Yes	0

BIT	FUNCTION	TYPE	DESCRIPTION	EEPROM/ I2C-SMBUS	DEFAULT
18	Malformed TLP Mask	RW	When set, an event of Malformed TLP has been received is not logged in the Header Log register and not issued as an Error Message to RC either.	Yes	0
19	ECRC Error Mask	RW	When set, an event of ECRC Error has been detected is not logged in the Header Log register and not issued as an Error Message to RC either.	Yes	0
20	Unsupported Request Error Mask	RW	When set, the Unsupported Request event is not logged in the Header Log register and not issued as an Error Message to RC either.	Yes	0
21	ACS Violation Mask	RW	When set, the ACS Violation event is not logged in the Header Log register and not issued as an Error Message to RC either.	Yes	0
22	Internal Error Mask	RW	When set, the Internal Error event is not logged in the Header Log register and not issued as an Error Message to RC either.	Yes	1
23	MC Blocked TLP Mask	RW	When set, the MC Blocked TLP event is not logged in the Header Log register and not issued as an Error Message to RC either.	Yes	0
24	AtomicOp Egress Blocked Mask	RW	When set, the AtomicOp Egress Blocked event is not logged in the Header Log register and not issued as an Error Message to RC either.	Yes	0
31:25	Reserved	RsvdP	Not support.	No	0000_000b

9.4.66 UNCORRECTABLE ERROR SEVERITY REGISTER – OFFSET 10Ch

BIT	FUNCTION	TYPE	DESCRIPTION	EEPROM/ I2C-SMBUS	DEFAULT
0	Training Error Severity	RW	0b: Non-Fatal 1b: Fatal	Yes	1
3:1	Reserved	RsvdP	Not support.	No	000b
4	Data Link Protocol Error Severity	RW	0b: Non-Fatal 1b: Fatal	Yes	1
5	Surprise Down Error Severity	RW	0b: Non-Fatal 1b: Fatal	Yes	1
11:6	Reserved	RsvdP	Not support.	No	0-0b
12	Poisoned TLP Severity	RW	0b: Non-Fatal 1b: Fatal	Yes	0
13	Flow Control Protocol Error Severity	RW	0b: Non-Fatal 1b: Fatal	Yes	1
14	Completion Timeout Error Severity	RW	0b: Non-Fatal 1b: Fatal	Yes	0
15	Completer Abort Severity	RW	0b: Non-Fatal 1b: Fatal	Yes	0
16	Unexpected Completion Severity	RW	0b: Non-Fatal 1b: Fatal	Yes	0
17	Receiver Overflow Severity	RW	0b: Non-Fatal 1b: Fatal	Yes	1
18	Malformed TLP Severity	RW	0b: Non-Fatal 1b: Fatal	Yes	1
19	ECRC Error Severity	RW	0b: Non-Fatal 1b: Fatal	Yes	0
20	Unsupported Request Error Severity	RW	0b: Non-Fatal 1b: Fatal	Yes	0
21	ACS Violation Severity	RW	0b: Non-Fatal 1b: Fatal	Yes	0
22	Internal Error Severity	RW	0b: Non-Fatal 1b: Fatal	Yes	1
23	MC Blocked TLP Severity	RW	0b: Non-Fatal 1b: Fatal	Yes	0
24	AtomicOp Egress Blocked Severity	RW	0b: Non-Fatal 1b: Fatal	Yes	0
31:25	Reserved	RsvdP	Not support.	No	0000_000b

9.4.67 CORRECTABLE ERROR STATUS REGISTER – OFFSET 110h

BIT	FUNCTION	TYPE	DESCRIPTION	EEPROM/ I2C-SMBUS	DEFAULT
0	Receiver Error Status	RW1C	When set, the Receiver Error event is detected.	Yes	0
5:1	Reserved	RsvdP	Not support.	No	0_000b
6	Bad TLP Status	RW1C	When set, the event of Bad TLP has been received is detected.	Yes	0
7	Bad DLLP Status	RW1C	When set, the event of Bad DLLP has been received is detected.	Yes	0
8	REPLAY_NUM Rollover Status	RW1C	When set, the REPLAY_NUM Rollover event is detected.	Yes	0
11:9	Reserved	RsvdP	Not support.	No	000b
12	Replay Timer Timeout Status	RW1C	When set, the Replay Timer Timeout event is detected.	Yes	0
13	Advisory Non-Fatal Error Status	RW1C	When set, the Advisory Non-Fatal Error event is detected.	Yes	0
14	Corrected Internal Error Status	RW1C	When set, the Corrected Internal Error event is detected.	Yes	0
31:15	Reserved	RsvdP	Not support.	No	0-0h

9.4.68 CORRECTABLE ERROR MASK REGISTER – OFFSET 114h

BIT	FUNCTION	TYPE	DESCRIPTION	EEPROM/ I2C-SMBUS	DEFAULT
0	Receiver Error Mask	RW	When set, the Receiver Error event is not logged in the Header Log register and not issued as an Error Message to RC either.	Yes	0
5:1	Reserved	RsvdP	Not support.	No	0_000b
6	Bad TLP Mask	RW	When set, the event of Bad TLP has been received is not logged in the Header Log register and not issued as an Error Message to RC either.	Yes	0
7	Bad DLLP Mask	RW	When set, the event of Bad DLLP has been received is not logged in the Header Log register and not issued as an Error Message to RC either.	Yes	0
8	REPLAY_NUM Rollover Mask	RW	When set, the REPLAY_NUM Rollover event is not logged in the Header Log register and not issued as an Error Message to RC either.	Yes	0
11:9	Reserved	RsvdP	Not support.	No	000b
12	Replay Timer Timeout Mask	RW	When set, the Replay Timer Timeout event is not logged in the Header Log register and not issued as an Error Message to RC either.	Yes	0
13	Advisory Non-Fatal Error Mask	RW	When set, the Advisory Non-Fatal Error event is not logged in the Header Long register and not issued as an Error Message to RC either.	Yes	1
14	Corrected Internal Error Mask	RW	When set, the corrected internal error event is not logged in the Header Log register and not issued as an Error Message to RC either.	Yes	1
31:15	Reserved	RsvdP	Not support.	No	0-0h

9.4.69 ADVANCE ERROR CAPABILITIES AND CONTROL REGISTER – OFFSET 118h

BIT	FUNCTION	TYPE	DESCRIPTION	EEPROM/ I2C-SMBUS	DEFAULT
4:0	First Error Pointer	RO	It indicates the bit position of the first error reported in the Uncorrectable Error Status register.	No	0_0000b
5	ECRC Generation Capable	RO	When set, it indicates the Switch has the capability to generate ECRC.	Yes	1
6	ECRC Generation Enable	RW	When set, it enables the generation of ECRC when needed.	Yes	0
7	ECRC Check Capable	RO	When set, it indicates the Switch has the capability to check ECRC.	Yes	1
8	ECRC Check Enable	RW	When set, the function of checking ECRC is enabled.	Yes	0
31:9	Reserved	RsvdP	Not support.	No	0-0h

9.4.70 HEADER LOG REGISTER – OFFSET From 11Ch to 128h

BIT	FUNCTION	TYPE	DESCRIPTION	EEPROM/ I2C-SMBUS	DEFAULT
31:0	1 st DWORD	RO	Hold the 1st DWORD of TLP Header. The Head byte is in big endian.	No	0000_0000h
63:32	2 nd DWORD	RO	Hold the 2nd DWORD of TLP Header. The Head byte is in big endian.	No	0000_0000h
95:64	3 rd DWORD	RO	Hold the 3rd DWORD of TLP Header. The Head byte is in big endian.	No	0000_0000h
127:96	4 th DWORD	RO	Hold the 4th DWORD of TLP Header. The Head byte is in big endian.	No	0000_0000h

9.4.71 PCI EXPRESS VIRTUAL CHANNEL ENHANCED CAPABILITY REGISTER – OFFSET 130h

BIT	FUNCTION	TYPE	DESCRIPTION	EEPROM/ I2C-SMBUS	DEFAULT
15:0	Extended Capabilities ID	RO	Read as 0002h to indicate that this is PCI express extended capability register for virtual channel.	No	02h
19:16	Capability Version	RO	Read as 1h.	No	1h
31:20	Next Capability Offset	RO	Point to next PCI extended capability structure.	Yes	1A0h

9.4.72 PORT VC CAPABILITY REGISTER 1 – OFFSET 134h

BIT	FUNCTION	TYPE	DESCRIPTION	EEPROM/ I2C-SMBUS	DEFAULT
2:0	Extended VC Count	RO	It indicates the number of extended Virtual Channels in addition to the default VC supported by the Switch.	No	000b
3	Reserved	RO	Not support.	No	0
6:4	Low Priority Extended VC Count	RO	It indicates the number of extended Virtual Channels in addition to the default VC belonging to the low-priority VC (LPVC) group.	No	000b
7	Reserved	RO	Not support.	No	0
9:8	Reference Clock	RO	It indicates the reference clock for Virtual Channels that support time-based WRR Port Arbitration. Defined encoding is 00b for 100 ns reference clock.	No	00b
11:10	Port Arbitration Table Entry Size	RO	Read as 10b to indicate the size of Port Arbitration table entry in the device is 4 bits.	No	10b
31:12	Reserved	RsvdP	Not support.	No	0000_0h

9.4.73 PORT VC CAPABILITY REGISTER 2 – OFFSET 138h

BIT	FUNCTION	TYPE	DESCRIPTION	EEPROM/ I2C-SMBUS	DEFAULT
7:0	VC Arbitration Capability	RO	It indicates the types of VC Arbitration supported by the device for the LPVC group. This field is valid when LPVC is greater than 0. The Switch supports Hardware fixed arbitration scheme, e.g., Round Robin and Weight Round Robin arbitration with 32 phases in LPVC.	No	00h
23:8	Reserved	RsvdP	Not support.	No	0000h
31:24	VC Arbitration Table Offset	RO	It indicates the location of the VC Arbitration Table as an offset from the base address of the Virtual Channel Capability register in the unit of DQWD (16 bytes).	No	00h

9.4.74 PORT VC CONTROL REGISTER – OFFSET 13Ch

BIT	FUNCTION	TYPE	DESCRIPTION	EEPROM/ I2C-SMBUS	DEFAULT
0	Load VC Arbitration Table	WO	When set, the programmed VC Arbitration Table is applied to the hardware. This bit always returns 0b when read.	Yes/No	0

BIT	FUNCTION	TYPE	DESCRIPTION	EEPROM/ I2C-SMBUS	DEFAULT
3:1	VC Arbitration Select	RW	This field is used to configure the VC Arbitration by selecting one of the supported VC Arbitration schemes. The valid values for the schemes supported by Switch are 0b and 1b. Other value than these written into this register will be treated as default.	Yes/No	000b
15:4	Reserved	RsvdP	Not support.	No	000h

9.4.75 PORT VC STATUS REGISTER – OFFSET 13Ch

BIT	FUNCTION	TYPE	DESCRIPTION	EEPROM/ I2C-SMBUS	DEFAULT
16	VC Arbitration Table Status	RO	When set, it indicates that any entry of the VC Arbitration Table is written by software. This bit is cleared when hardware finishes loading values stored in the VC Arbitration Table after the bit of “Load VC Arbitration Table” is set.	No	0
31:17	Reserved	RsvdP	Not support.	No	0-0h

9.4.76 VC RESOURCE CAPABILITY REGISTER (0) – OFFSET 140h

BIT	FUNCTION	TYPE	DESCRIPTION	EEPROM/ I2C-SMBUS	DEFAULT
7:0	Port Arbitration Capability	RO	It indicates the types of Port Arbitration supported by the VC resource. The Switch supports Round Robin Hardware fixed arbitration scheme.	No	01h
13:8	Reserved	RsvdP	Not support.	No	00_0000h
14	Advanced Packet Switching	RO	When set, it indicates the VC resource only supports transaction optimized for Advanced Packet Switching (AS).	No	0
15	Reject Snoop Transactions	RsvdP	Not support.	No	0
22:16	Maximum Time Slots	RO	It indicates the maximum numbers of time slots (minus one) are allocated for Isochronous traffic.	No	3Fh
23	Reserved	RsvdP	Not support.	No	0
31:24	Port Arbitration Table Offset	RO	It indicates the location of the Port Arbitration Table (n) as an offset from the base address of the Virtual Channel Capability register in the unit of DQWD (16 bytes).	No	05h

9.4.77 VC RESOURCE CONTROL REGISTER (0)– OFFSET 144h

BIT	FUNCTION	TYPE	DESCRIPTION	EEPROM/ I2C-SMBUS	DEFAULT
7:0	TC/VC Map	RW	This field indicates the TCs that are mapped to the VC resource. Bit locations within this field correspond to TC values. When the bits in this field are set, it means that the corresponding TCs are mapped to the VC resource. Bit 0 of this field is read-only and must be set to “1” for the VC0.	Yes	FFh
15:8	Reserved	RsvdP	Not support.	No	00h
16	Load Port Arbitration Table	RW	When set, the programmed Port Arbitration Table is applied to the hardware. This bit always returns 0b when read.	Yes	0
19:17	Port Arbitration Select	RW	This field is used to configure the Port Arbitration by selecting one of the supported Port Arbitration schemes. The permissible values for the schemes supported by Switch are 000b and 011b at VC0, other value than these written into this register will be treated as default.	Yes	000b
23:20	Reserved	RsvdP	Not support.	No	0h
26:24	VC ID	RO	This field assigns a VC ID to the VC resource.	No	000b
30:27	Reserved	RsvdP	Not support.	No	0h
31	VC Enable	RW	0b: it disables this Virtual Channel 1b: it enables this Virtual Channel	Yes	1

9.4.78 VC RESOURCE STATUS REGISTER (0) – OFFSET 148h

BIT	FUNCTION	TYPE	DESCRIPTION	EEPROM/ I2C-SMBUS	DEFAULT
15:0	Reserved	RsvdP	Not support.	No	0000h
16	Port Arbitration Table Status	RO	When set, it indicates that any entry of the Port Arbitration Table is written by software. This bit is cleared when hardware finishes loading values stored in the Port Arbitration Table after the bit of “Load Port Arbitration Table” is set.	No	0
17	VC Negotiation Pending	RO	When set, it indicates that the VC resource is still in the process of negotiation. This bit is cleared after the VC negotiation is complete.	No	1
31:18	Reserved	RsvdP	Not support.	No	0-0h

9.4.79 DEVICE SERIAL NUMBER ENHANCED CAPABILITY HEADER REGISTER – OFFSET 1A0h

BIT	FUNCTION	TYPE	DESCRIPTION	EEPROM/ I2C-SMBUS	DEFAULT
15:0	Extended Capabilities ID	RO	Indicates that these are PCI express extended capability registers for device serial number extend capability register.	No	0003h
19:16	Capability Version	RO	Must be 1h for this version.	No	1h
31:20	Next Capability Offset	RO	Pointer points to the Power Budget Extended Capability structure.	Yes	1B0h

9.4.80 DEVICE SERIAL NUMBER LOWER DW REGISTER – OFFSET 1A4h

BIT	FUNCTION	TYPE	DESCRIPTION	EEPROM/ I2C-SMBUS	DEFAULT
31:0	Device serial number 1 st DW	RO	First dword for device serial number.	Yes	0000_12D8h

9.4.81 DEVICE SERIAL NUMBER HIGHER DW REGISTER – OFFSET 1A8h

BIT	FUNCTION	TYPE	DESCRIPTION	EEPROM/ I2C-SMBUS	DEFAULT
31:0	Device serial number 2 nd DW	RO	2 nd dword for device serial number.	Yes	0816_4896h

9.4.82 PCI EXPRESS POWER BUDGETING ENHANCED CAPABILITY HEADER REGISTER – OFFSET 1B0h

BIT	FUNCTION	TYPE	DESCRIPTION	EEPROM/ I2C-SMBUS	DEFAULT
15:0	Extended Capabilities ID	RO	Read as 0004h to indicate that this is PCI express extended capability register for power budgeting.	No	0004h
19:16	Capability Version	RO	Must be 1h for this version.	No	01h
31:20	Next Capability Offset	RO	Point to next PCI extended capability structure.	Yes	210h

9.4.83 DATA SELECT REGISTER – OFFSET 1B4h

BIT	FUNCTION	TYPE	DESCRIPTION	EEPROM/ I2C-SMBUS	DEFAULT
7:0	Data Selection	RW	It indexes the power budgeting data reported through the data register. When 00h, it selects D0 Max power budget When 01h, it selects D0 Sustained power budget Other values would return zero power budgets, which means Not supported.	Yes	00h
31:8	Reserved	RsvdP	Not support.	No	0-0h

9.4.84 POWER BUDGETING DATA REGISTER – OFFSET 1B8h

BIT	FUNCTION	TYPE	DESCRIPTION	EEPROM/ I2C-SMBUS	DEFAULT
7:0	Base Power	RO	It specifies the base power value in watts. This value represents the required power budget in the given operation condition.	Yes	04h if 13Ch.bit[0]=0 03h if 13Ch.bit[0]=1
9:8	Data Scale	RO	It specifies the scale to apply to the base power value.	Yes	00b
12:10	PM Sub State	RO	It specifies the power management sub state of the given operation condition. It is initialized to the default sub state.	No	000b
14:13	PM State	RO	It specifies the power management state of the given operation condition. It defaults to the D0 power state.	Yes	00b
17:15	Type	RO	It specifies the type of the given operation condition which is controlled by offset 13Ch[7:0] . It defaults to the Maximum power state.	Yes	7h if 13Ch.bit[0]=0 3h if 13Ch.bit[0]=1
20:18	Power Rail	RO	It specifies the power rail of the given operation condition..	Yes	010b
31:21	Reserved	RsvdP	Not support.	No	0-0h

9.4.85 POWER BUDGET CAPABILITY REGISTER – OFFSET 1BCh

BIT	FUNCTION	TYPE	DESCRIPTION	EEPROM/ I2C-SMBUS	DEFAULT
0	System Allocated	RO	When set, it indicates that the power budget for the device is included within the system power budget.	Yes	1
31:1	Reserved	RsvdP	Not support.	No	0-0h

9.4.86 SECONDARY PCI EXPRESS EXTENDED CAPABILITY HEADER – OFFSET 210h

BIT	FUNCTION	TYPE	DESCRIPTION	EEPROM/ I2C-SMBUS	DEFAULT
15:0	PCI Express Extended Capability ID	RO	Read as 0019h to indicate that this is PCI Express Extended Capability register for Secondary PCI Express.	No	0019h
19:16	Capability Version	RO	Must be 1h for this version.	No	1h
31:20	Next Capability ID	RO	Point to next PCI extended capability structure.	Yes	2B0h

9.4.87 LINK CONTROL 3 REGISTER – OFFSET 214h

BIT	FUNCTION	TYPE	DESCRIPTION	EEPROM/ I2C-SMBUS	DEFAULT
0	Perform Equalization	RW	When this bit is 1b and a 1b is written to the Retrain Link bit with the Target Link Speed field set to 8.0 GT/s, the downstream port must perform Link Equalization.	Yes	0
1	Link Equalization Request Interrupt Enable	RW	When set, this bit enables the generation of an interrupt to indicate that the Link Equalization bit has been set.	Yes	0
31:2	Reserved	RsvdP	Not support.	No	0-0h

9.4.88 LANE ERROR STATUS REGISTER – OFFSET 218h

BIT	FUNCTION	TYPE	DESCRIPTION	EEPROM/ I2C-SMBUS	DEFAULT
31:0	Lane Error Status	RW1C	Each bit indicates if the corresponding Lane detected a Lane-base error.	Yes	0000_0000h

9.4.89 LANE EQUALIZATION CONTROL REGISTER – OFFSET 21Ch – 230h

Table 9-4: Lane Equalization Control Register Locations

CFG_OFFSET	Lane Number	CFG_OFFSET	Lane Number
21Ch	0	22Ch	8
21Eh	1	22Eh	9
220h	2	230h	10
222h	3	232h	11
224h	4	234h	12
226h	5	236h	13
228h	6	238h	14
22Ah	7	23Ah	15

Table 9-5: Lane Equalization Control Register Definitions

BIT	FUNCTION	TYPE	DESCRIPTION	EEPROM/ I2C-SMBUS	DEFAULT
3:0	Downstream Port Transmitter Preset	RW	Transmitter Preset used for equalization by this Port.	No	0
7:4	Downstream Port Receiver Preset Hint	RW	Receiver Preset Hint may be used as a hint for receiver equalization by this Port.	No	0
11:8	Upstream Port Transmitter Preset	RO	Field contains the Transmit Preset value sent or received during Link Equalization.	No	8h
14:12	Upstream Port Receiver Preset Hint	RO	Field contains the Receiver Preset Hint value sent or received during Link Equalization.	No	2h
15	Reserved	RsvdP	Not support.	No	0

9.4.90 LI PM SUBSTATES ENHANCED CAPABILITY HEADER – OFFSET 2B0h

BIT	FUNCTION	TYPE	DESCRIPTION	EEPROM/ I2C-SMBUS	DEFAULT
15:0	PCI Express Extended Capability ID	RO	Read as 001Eh to indicate that this is PCI Express Extended Capability register for L1 PM Substates.	No	001Eh
19:16	Capability Version	RO	Must be 1h for this version.	No	1h
31:20	Next Capability ID	RO	Point to next PCI extended capability structure.	Yes	300h

9.4.91 L1 PM SUBSTATES CAPABILITY REGISTER – OFFSET 2B4h

BIT	FUNCTION	TYPE	DESCRIPTION	EEPROM/ I2C-SMBUS	DEFAULT
0	PCI-PM L1.2 Supported	RO	When set this bit indicates that PCI-PM L1.2 is supported.	Yes	0
1	PCI-PM L1.1 Supported	RO	When set this bit indicates that PCI-PM L1.1 is supported and must be set by all ports implementing L1 PM Substates.	Yes	0
2	ASPM L1.2 Supported	RO	When set this bit indicates that ASPM L1.2 is supported.	Yes	0
3	ASPM L1.1 Supported	RO	When set this bit indicates that ASPM L1.1 is supported.	Yes	0
4	L1 PM Substates Supported	RO	When set this bit indicates that this port supports L1 PM Substates.	Yes	1
31:5	Reserved	RsvdP	Not support.	No	0-0h

9.4.92 L1 PM SUBSTATES CONTROL 1 REGISTER – OFFSET 2B8h

BIT	FUNCTION	TYPE	DESCRIPTION	EEPROM/ I2C-SMBUS	DEFAULT
0	PCI-PM L1.2 Enable	RW	When set this bit enables PCI-PM L1.2. Required.	Yes	0
1	PCI-PM L1.1 Enable	RW	When set this bit enables PCI-PM L1.1. Required.	Yes	0
2	ASPM L1.2 Enable	RW	When set this bit enables ASPM L1.2. Required.	Yes	0
3	ASPM L1.1 Enable	RW	When set this bit enables ASPM L1.1. Required.	Yes	0
31:4	Reserved	RsvdP	Not support.	No	0-0h

9.4.93 L1 PM SUBSTATES CONTROL 2 REGISTER – OFFSET 2BCh

BIT	FUNCTION	TYPE	DESCRIPTION	EEPROM/ I2C-SMBUS	DEFAULT
31:0	Reserved	RsvdP	Not support.	No	0000_0000h

9.4.94 CDEP DATA 2 REGISTER – OFFSET 2E0h

BIT	FUNCTION	TYPE	DESCRIPTION	EEPROM/ I2C-SMBUS	DEFAULT
15:0	Reserved	RsvdP	Not support.	No	0000h
16	cfg_written_mode	RW	1b: can be written by MCPU only 0b: can be written by both MCPU/LH	Yes	0
31:17	Reserved	RsvdP	Not support.	No	0000h

9.4.95 VENDOR-SPECIFIC ENHANCED CAPABILITY HEADER – OFFSET 300h

BIT	FUNCTION	TYPE	DESCRIPTION	EEPROM/ I2C-SMBUS	DEFAULT
15:0	PCI Express Extended Capability ID	RO	Read as 000Bh to indicate that this is PCI Express Extended Capability register for Vendor-Specific.	No	000Bh
19:16	Capability Version	RO	Must be 1h for this version.	No	1h
31:20	Next Capability ID	RO	Point to next PCI extended capability structure.	No	900h

9.4.96 VENDOR-SPECIFIC HEADER – OFFSET 304h

BIT	FUNCTION	TYPE	DESCRIPTION	EEPROM/ I2C-SMBUS	DEFAULT
15:0	VSEC ID	RO	This field is a vendor-defined ID number that indicates the nature and format of the VSEC structure.	Yes	0000h
19:16	VSEC Rev	RO	This field is a vendor-defined version number that indicates the version of the VSEC structure.	No	0h
31:20	VSEC Length	RO	This field indicates the number of bytes in the entire VSEC structure.	Yes	560h

9.4.97 DEBUGOUT CONTROL REGISTER – OFFSET 310h (Port 0 Only)

BIT	FUNCTION	TYPE	DESCRIPTION	EEPROM/ I2C-SMBUS	DEFAULT
4:0	Debug Mode Select	RW	Debug mode select. Selects a signal group for probing the current internal status. For example, “0” represents LTSSM signal group. As to other values, please inquire internal team for further information.	Yes	0_0000b
7:5	Debug Port_Select_S1	RW	Debug port select s1. Selects a port number for monitoring at a given signal group.	Yes	000b
8	DebugPort_Select_S2	RW	Debugport select s2.	Yes	0
9	Debug Output Start	RW	Start to capture debug output data.	Yes	0
31:10	Reserved	RsvdP	Not support.	No	0-0h

9.4.98 DEBUGOUT DATA REGISTER – OFFSET 314h (Port 0 Only)

BIT	FUNCTION	TYPE	DESCRIPTION	EEPROM/ I2C-SMBUS	DEFAULT
31:0	Debug Output Data	RO	Content of the debug output data. For example, if LTSSM signal group is selected, the meaning of debug output data is as follows. 001h: detect 002h: polling	No	0000_0000h

BIT	FUNCTION	TYPE	DESCRIPTION	EEPROM/ I2C-SMBUS	DEFAULT
			004h: configuration 008h: L0 010h: L1 020h: L2 040h: disable 080h: hot-reset 100h: loopback 200h: recovery Others: Reserved		

9.4.99 SMBUS CONTROL AND STATUS REGISTER – OFFSET 318h (Port 0 Only)

BIT	FUNCTION	TYPE	DESCRIPTION	EEPROM/ I2C-SMBUS	DEFAULT
0	SMBus Enabled	RW	Used to set SMBUS_EN_L strap pin. 0b: SMBus is disabled while I2C is enabled 1b: SMBus is enabled while I2C is disabled	Yes	Set by SMBUS_EN_L
3:1	I2C/SMBUS Address [2:0]	RW	Used to set I2C/SMBUS Address[2:0].	Yes	Set by I2C_ADDRESS_S [2:0]
7:4	I2C/SMBUS Address [6:3]	RW	Used to set I2C/SMBUS Address[6:3].	Yes	1101b
10	AV Flag	RW	Test used only.	Yes	0
11	AR Flag	RW	Test used only.	Yes	0
13:12	UDID Addr Type	RW	Test used only.	Yes	00b
14	UDID PEC Support	RW	Test used only.	Yes	1
15	Cross Strapping Done	RO	Test used only.	No	0
23:16	UDID Vendor ID	RW	Test used only.	Yes	B0h
26:24	UDID Revision ID	RW	Test used only.	Yes	001b
27	Fty Test 0	RW	Test used only.	Yes	0
28	SMBUS In Progress	RO	0b: SMBUS interface is idle 1b: SMBUS interface is busy	No	0
29	PEC Check Fail	RO	0b: PEC check successfully 1b: PEC check failed	No	0
30	Unsupported SMBUS Command	RO	0b: supported command 1b: unsupported command	No	0
31	Reserved	RO	Not support.	No	1

9.4.100 GPIO 0-15 DIRECTION CONTROL REGISTER – OFFSET 31Ch (Port 0 Only)

BIT	FUNCTION	TYPE	DESCRIPTION	EEPROM/ I2C-SMBUS	DEFAULT
0	GPIO[0] Source/Destination	RW	As Input: 0b: Input Data Register (offset 328h[0]) 1b: Generic Interrupt (INTx or MSI) As Output: 0b: From GPIO[0] Output Data register (offset 330h[0]) 1b: Reserved	Yes	0
1	GPIO[0] Direction Control	RW	0b: Input 1b: Output	Yes	0
2	GPIO[1] Source/Destination	RW	As Input: 0b: Input Data Register (offset 328h[1]) 1b: Generic Interrupt (INTx or MSI) As Output: 0b: From GPIO[1] Output Data register (offset 330h[1]) 1b: Reserved	Yes	0
3	GPIO[1] Direction Control	RW	0b: Input 1b: Output	Yes	0

BIT	FUNCTION	TYPE	DESCRIPTION	EEPROM/ I2C-SMBUS	DEFAULT
4	GPIO[2] Source/Destination	RW	As Input: 0b: Input Data Register (offset 328h[2]) 1b: General Interrupt (INTx or MSI) As Output: 0b: From GPIO[2] Output Data register (offset 330h[2]) 1b: Reserved	Yes	0
5	GPIO[2] Direction Control	RW	0b: Input 1b: Output	Yes	0
6	GPIO[3] Source/Destination	RW	As Input: 0b: Input Data Register (offset 328h[3]) 1b: General Interrupt (INTx or MSI) As Output: 0b: From GPIO[3] Output Data register (offset 330h[3]) 1b: Reserved	Yes	0
7	GPIO[3] Direction Control	RW	0b: Input 1b: Output	Yes	0
8	GPIO[4] Source/Destination	RW	As Input: 0b: Input Data Register (offset 328h[4]) 1b: General Interrupt (INTx or MSI) As Output: 0b: From GPIO[4] Output Data register (offset 330h[4]) 1b: Reserved	Yes	0
9	GPIO[4] Direction Control	RW	0b: Input 1b: Output	Yes	0
10	GPIO[5] Source/Destination	RW	As Input: 0b: Input Data Register (offset 328h[5]) 1b: General Interrupt (INTx or MSI) As Output: 0b: From GPIO[5] Output Data register (offset 330h[5]) 1b: Reserved	Yes	0
11	GPIO[5] Direction Control	RW	0b: Input 1b: Output	Yes	0
12	GPIO[6] Source/Destination	RW	As Input: 0b: Input Data Register (offset 328h[6]) 1b: General Interrupt (INTx or MSI) As Output: 0b: From GPIO[6] Output Data register (offset 330h[6]) 1b: Reserved	Yes	0
13	GPIO[6] Direction Control	RW	0b: Input 1b: Output	Yes	0
14	GPIO[7] Source/Destination	RW	As Input: 0b: Input Data Register (offset 328h[7]) 1b: General Interrupt (INTx or MSI) As Output: 0b: From GPIO[7] Output Data register (offset 330h[7]) 1b: Reserved	Yes	0
15	GPIO[7] Direction Control	RW	0b: Input 1b: Output	Yes	0
16	GPIO[8] Source/Destination	RW	As Input: 0b: Input Data Register (offset 328h[8]) 1b: General Interrupt (INTx or MSI) As Output: 0b: From GPIO[8] Output Data register (offset 330h[8]) 1b: Reserved	Yes	0
17	GPIO[8] Direction Control	RW	0b: Input 1b: Output	Yes	0
18	GPIO[9] Source/Destination	RW	As Input: 0b: Input Data Register (offset 328h[9]) 1b: General Interrupt (INTx or MSI) As Output: 0b: From GPIO[9] Output Data register (offset 330h[9]) 1b: Reserved	Yes	0
19	GPIO[9] Direction Control	RW	0b: Input 1b: Output	Yes	0

BIT	FUNCTION	TYPE	DESCRIPTION	EEPROM/ I2C-SMBUS	DEFAULT
20	GPIO[10] Source/Destination	RW	As Input: 0b: Input Data Register (offset 328h[10]) 1b: General Interrupt (INTx or MSI) As Output: 0b: From GPIO[10] Output Data register (offset 330h[10]) 1b: Reserved	Yes	0
21	GPIO[10] Direction Control	RW	0b: Input 1b: Output	Yes	0
22	GPIO[11] Source/Destination	RW	As Input: 0b: Input Data Register (offset 328h[11]) 1b: General Interrupt (INTx or MSI) As Output: 0b: From GPIO[11] Output Data register (offset 330h[11]) 1b: Reserved	Yes	0
23	GPIO[11] Direction Control	RW	0b: Input 1b: Output	Yes	0
24	GPIO[12] Source/Destination	RW	As Input: 0b: Input Data Register (offset 328h[12]) 1b: General Interrupt (INTx or MSI) As Output: 0b: From GPIO[12] Output Data register (offset 330h[12]) 1b: Reserved	Yes	0
25	GPIO[12] Direction Control	RW	0b: Input 1b: Output	Yes	0
26	GPIO[13] Source/Destination	RW	As Input: 0b: Input Data Register (offset 328h[13]) 1b: General Interrupt (INTx or MSI) As Output: 0b: From GPIO[13] Output Data register (offset 330h[13]) 1b: Reserved	Yes	0
27	GPIO[13] Direction Control	RW	0b: Input 1b: Output	Yes	0
28	GPIO[14] Source/Destination	RW	As Input: 0b: Input Data Register (offset 328h[14]) 1b: General Interrupt (INTx or MSI) As Output: 0b: From GPIO[14] Output Data register (offset 330h[14]) 1b: Reserved	Yes	0
29	GPIO[14] Direction Control	RW	0b: Input 1b: Output	Yes	0
30	GPIO[15] Source/Destination	RW	As Input: 0b: Input Data Register (offset 328h[15]) 1b: General Interrupt (INTx or MSI) As Output: 0b: From GPIO[15] Output Data register (offset 330h[15]) 1b: Reserved	Yes	0
31	GPIO[15] Direction Control	RW	0b: Input 1b: Output	Yes	0

9.4.101 GPIO 16-31 DIRECTION CONTROL REGISTER – OFFSET 320h (Port 0 Only)

BIT	FUNCTION	TYPE	DESCRIPTION	EEPROM/ I2C-SMBUS	DEFAULT
0	GPIO[16] Source/Destination	RW	As Input: 0b: Input Data Register (offset 32Ch[0]) 1b: General Interrupt (INTx or MSI) As Output: 0b: From GPIO[16] Output Data register (offset 334h[0]) 1b: Reserved	Yes	0
1	GPIO[16] Direction Control	RW	0b: Input 1b: Output	Yes	0

BIT	FUNCTION	TYPE	DESCRIPTION	EEPROM/ I2C-SMBUS	DEFAULT
2	GPIO[17] Source/Destination	RW	As Input: 0b: Input Data Register (offset 330h[1]) 1b: General Interrupt (INTx or MSI) As Output: 0b: From GPIO[17] Output Data register (offset 334h[1]) 1b: Reserved	Yes	0
3	GPIO[17] Direction Control	RW	0b: Input 1b: Output	Yes	0
4	GPIO[18] Source/Destination	RW	As Input: 0b: Input Data Register (offset 330h[2]) 1b: General Interrupt (INTx or MSI) As Output: 0b: From GPIO[18] Output Data register (offset 334h[2]) 1b: Reserved	Yes	0
5	GPIO[18] Direction Control	RW	0b: Input 1b: Output	Yes	0
6	GPIO[19] Source/Destination	RW	As Input: 0b: Input Data Register (offset 330h[3]) 1b: General Interrupt (INTx or MSI) As Output: 0b: From GPIO[19] Output Data register (offset 334h[3]) 1b: Reserved	Yes	0
7	GPIO[19] Direction Control	RW	0b: Input 1b: Output	Yes	0
8	GPIO[20] Source/Destination	RW	As Input: 0b: Input Data Register (offset 330h[4]) 1b: General Interrupt (INTx or MSI) As Output: 0b: From GPIO[20] Output Data register (offset 334h[4]) 1b: Reserved	Yes	0
9	GPIO[20] Direction Control	RW	0b: Input 1b: Output	Yes	0
10	GPIO[21] Source/Destination	RW	As Input: 0b: Input Data Register (offset 330h[5]) 1b: General Interrupt (INTx or MSI) As Output: 0b: From GPIO[21] Output Data register (offset 334h[5]) 1b: Reserved	Yes	0
11	GPIO[21] Direction Control	RW	0b: Input 1b: Output	Yes	0
12	GPIO[22] Source/Destination	RW	As Input: 0b: Input Data Register (offset 330h[6]) 1b: General Interrupt (INTx or MSI) As Output: 0b: From GPIO[22] Output Data register (offset 334h[6]) 1b: Reserved	Yes	0
13	GPIO[22] Direction Control	RW	0b: Input 1b: Output	Yes	0
14	GPIO[23] Source/Destination	RW	As Input: 0b: Input Data Register (offset 330h[7]) 1b: General Interrupt (INTx or MSI) As Output: 0b: From GPIO[23] Output Data register (offset 334h[7]) 1b: Reserved	Yes	0
15	GPIO[23] Direction Control	RW	0b: Input 1b: Output	Yes	0
16	GPIO[24] Source/Destination	RW	As Input: 0b: Input Data Register (offset 330h[8]) 1b: General Interrupt (INTx or MSI) As Output: 0b: From GPIO[24] Output Data register (offset 334h[8]) 1b: Reserved	Yes	0
17	GPIO[24] Direction Control	RW	0b: Input 1b: Output	Yes	0

BIT	FUNCTION	TYPE	DESCRIPTION	EEPROM/ I2C-SMBUS	DEFAULT
18	GPIO[25] Source/Destination	RW	As Input: 0b: Input Data Register (offset 330h[9]) 1b: General Interrupt (INTx or MSI) As Output: 0b: From GPIO[25] Output Data register (offset 334h[9]) 1b: Reserved	Yes	0
19	GPIO[25] Direction Control	RW	0b: Input 1b: Output	Yes	0
20	GPIO[26] Source/Destination	RW	As Input: 0b: Input Data Register (offset 330h[10]) 1b: General Interrupt (INTx or MSI) As Output: 0b: From GPIO[26] Output Data register (offset 334h[10]) 1b: Reserved	Yes	0
21	GPIO[26] Direction Control	RW	0b: Input 1b: Output	Yes	0
22	GPIO[27] Source/Destination	RW	As Input: 0b: Input Data Register (offset 330h[11]) 1b: General Interrupt (INTx or MSI) As Output: 0b: From GPIO[27] Output Data register (offset 334h[11]) 1b: Reserved	Yes	0
23	GPIO[27] Direction Control	RW	0b: Input 1b: Output	Yes	0
24	GPIO[28] Source/Destination	RW	As Input: 0b: Input Data Register (offset 330h[12]) 1b: General Interrupt (INTx or MSI) As Output: 0b: From GPIO[28] Output Data register (offset 334h[12]) 1b: Reserved	Yes	0
25	GPIO[28] Direction Control	RW	0b: Input 1b: Output	Yes	0
26	GPIO[29] Source/Destination	RW	As Input: 0b: Input Data Register (offset 330h[13]) 1b: General Interrupt (INTx or MSI) As Output: 0b: From GPIO[29] Output Data register (offset 334h[13]) 1b: Reserved	Yes	0
27	GPIO[29] Direction Control	RW	0b: Input 1b: Output	Yes	0
28	GPIO[30] Source/Destination	RW	As Input: 0b: Input Data Register (offset 330h[14]) 1b: General Interrupt (INTx or MSI) As Output: 0b: From GPIO[30] Output Data register (offset 334h[14]) 1b: Reserved	Yes	0
29	GPIO[30] Direction Control	RW	0b: Input 1b: Output	Yes	0
30	GPIO[31] Source/Destination	RW	As Input: 0b: Input Data Register (offset 330h[15]) 1b: General Interrupt (INTx or MSI) As Output: 0b: From GPIO[31] Output Data register (offset 334h[15]) 1b: Reserved	Yes	0
31	GPIO[31] Direction Control	RW	0b: Input 1b: Output	Yes	0

9.4.102 GPIO INPUT DE-BOUNCE REGISTER – OFFSET 324h (Port 0 Only)

BIT	FUNCTION	TYPE	DESCRIPTION	EEPROM/ I2C-SMBUS	DEFAULT
31:0	GPIOx Input De- Bounce Control	RW	Controls de-bounce when the corresponding GPIOx signal is configured as an input. Bit[31:0] correspond to GPIO[31:0], respectively.	Yes	0000_0000h

BIT	FUNCTION	TYPE	DESCRIPTION	EEPROM/ I2C-SMBUS	DEFAULT
			0b: GPIOx input is not de-bounced 1b: GPIOx input is de-bounced		

9.4.103 GPIO 0-15 INPUT DATA REGISTER – OFFSET 328h (Port 0 Only)

BIT	FUNCTION	TYPE	DESCRIPTION	EEPROM/ I2C-SMBUS	DEFAULT
0	GPIO[0] Input Data	RW	GPIO[0] Input Data Return 0 if GPIO[0] is configured as an output (offset 31Ch[1]=1) Return the state of GPIO[0] pin if GPIO[0] is configured as an input (offset 31Ch[1]=0)	Yes	Set by GPIO[0]
1	GPIO[1] Input Data	RW	GPIO[1] Input Data Return 0 if GPIO[1] is configured as an output (offset 31Ch[3]=1) Return the state of GPIO[1] pin if GPIO[1] is configured as an input (offset 31Ch[3]=0)	Yes	Set by GPIO[1]
2	GPIO[2] Input Data	RW	GPIO[2] Input Data Return 0 if GPIO[2] is configured as an output (offset 31Ch[5]=1) Return the state of GPIO[2] pin if GPIO[2] is configured as an input (offset 31Ch[5]=0)	Yes	Set by GPIO[2]
3	GPIO[3] Input Data	RW	GPIO[3] Input Data Return 0 if GPIO[3] is configured as an output (offset 31Ch[7]=1) Return the state of GPIO[3] pin if GPIO[3] is configured as an input (offset 31Ch[7]=0)	Yes	Set by GPIO[3]
4	GPIO[4] Input Data	RW	GPIO[4] Input Data Return 0 if GPIO[4] is configured as an output (offset 31Ch[9]=1) Return the state of GPIO[4] pin if GPIO[4] is configured as an input (offset 31Ch[9]=0)	Yes	Set by GPIO[4]
5	GPIO[5] Input Data	RW	GPIO[5] Input Data Return 0 if GPIO[5] is configured as an output (offset 31Ch[11]=1) Return the state of GPIO[5] pin if GPIO[5] is configured as an input (offset 31Ch[11]=0)	Yes	Set by GPIO[5]
6	GPIO[6] Input Data	RW	GPIO[6] Input Data Return 0 if GPIO[6] is configured as an output (offset 31Ch[13]=1) Return the state of GPIO[6] pin if GPIO[6] is configured as an input (offset 31Ch[13]=0)	Yes	Set by GPIO[6]
7	GPIO[7] Input Data	RW	GPIO[7] Input Data Return 0 if GPIO[7] is configured as an output (offset 31Ch[15]=1) Return the state of GPIO[7] pin if GPIO[7] is configured as an input (offset 31Ch[15]=0)	Yes	Set by GPIO[7]
8	GPIO[8] Input Data	RW	GPIO[8] Input Data Return 0 if GPIO[8] is configured as an output (offset 31Ch[17]=1) Return the state of GPIO[8] pin if GPIO[8] is configured as an input (offset 31Ch[17]=0)	Yes	Set by GPIO[8]
9	GPIO[9] Input Data	RW	GPIO[9] Input Data Return 0 if GPIO[9] is configured as an output (offset 31Ch[19]=1) Return the state of GPIO[9] pin if GPIO[9] is configured as an input (offset 31Ch[19]=0)	Yes	Set by GPIO[9]
10	GPIO[10] Input Data	RW	GPIO[10] Input Data Return 0 if GPIO[10] is configured as an output (offset 31Ch[21]=1) Return the state of GPIO[10] pin if GPIO[10] is configured as an input (offset 31Ch[21]=0)	Yes	Set by GPIO[10]
11	GPIO[11] Input Data	RW	GPIO[11] Input Data Return 0 if GPIO[11] is configured as an output (offset 31Ch[23]=1) Return the state of GPIO[11] pin if GPIO[11] is configured as an input (offset 31Ch[23]=0)	Yes	Set by GPIO[11]
12	GPIO[12] Input Data	RW	GPIO[12] Input Data Return 0 if GPIO[12] is configured as an output (offset 31Ch[25]=1) Return the state of GPIO[12] pin if GPIO[12] is configured as an input (offset 31Ch[25]=0)	Yes	Set by GPIO[12]
13	GPIO[13] Input Data	RW	GPIO[13] Input Data Return 0 if GPIO[13] is configured as an output (offset 31Ch[27]=1) Return the state of GPIO[13] pin if GPIO[13] is configured as an input (offset 31Ch[27]=0)	Yes	Set by GPIO[13]

BIT	FUNCTION	TYPE	DESCRIPTION	EEPROM/ I2C-SMBUS	DEFAULT
14	GPIO[14] Input Data	RW	GPIO[14] Input Data Return 0 if GPIO[14] is configured as an output (offset 31Ch[29]=1) Return the state of GPIO[14] pin if GPIO[14] is configured as an input (offset 31Ch[29]=0)	Yes	Set by GPIO[14]
15	GPIO[15] Input Data	RW	GPIO[15] Input Data Return 0 if GPIO[15] is configured as an output (offset 31Ch[31]=1) Return the state of GPIO[15] pin if GPIO[15] is configured as an input (offset 31Ch[31]=0)	Yes	Set by GPIO[15]
31:16	Reserved	RsvdP	Not support.	No	0000h

9.4.104 GPIO 16-31 INPUT DATA REGISTER – OFFSET 32Ch (Port 0 Only)

BIT	FUNCTION	TYPE	DESCRIPTION	EEPROM/ I2C-SMBUS	DEFAULT
0	GPIO[16] Input Data	RO	GPIO[16] Input Data Return 0 if GPIO[16] is configured as an output (offset 320h[1]=1) Return the state of GPIO[16] pin if GPIO[16] is configured as an input (offset 320h[1]=0)	Yes	Set by GPIO[16]
1	GPIO[17] Input Data	RO	GPIO[17] Input Data Return 0 if GPIO[17] is configured as an output (offset 320h[3]=1) Return the state of GPIO[17] pin if GPIO[17] is configured as an input (offset 320h[3]=0)	Yes	Set by GPIO[17]
2	GPIO[18] Input Data	RO	GPIO[18] Input Data Return 0 if GPIO[18] is configured as an output (offset 320h[5]=1) Return the state of GPIO[18] pin if GPIO[18] is configured as an input (offset 320h[5]=0)	Yes	Set by GPIO[18]
3	GPIO[19] Input Data	RO	GPIO[19] Input Data Return 0 if GPIO[19] is configured as an output (offset 320h[7]=1) Return the state of GPIO[19] pin if GPIO[19] is configured as an input (offset 320h[7]=0)	Yes	Set by GPIO[19]
4	GPIO[20] Input Data	RO	GPIO[20] Input Data Return 0 if GPIO[20] is configured as an output (offset 320h[9]=1) Return the state of GPIO[20] pin if GPIO[20] is configured as an input (offset 320h[9]=0)	Yes	Set by GPIO[20]
5	GPIO[21] Input Data	RO	GPIO[21] Input Data Return 0 if GPIO[21] is configured as an output (offset 320h[11]=1) Return the state of GPIO[21] pin if GPIO[21] is configured as an input (offset 320h[11]=0)	Yes	Set by GPIO[21]
6	GPIO[22] Input Data	RO	GPIO[22] Input Data Return 0 if GPIO[22] is configured as an output (offset 320h[13]=1) Return the state of GPIO[22] pin if GPIO[22] is configured as an input (offset 320h[13]=0)	Yes	Set by GPIO[22]
7	GPIO[23] Input Data	RO	GPIO[23] Input Data Return 0 if GPIO[23] is configured as an output (offset 320h[15]=1) Return the state of GPIO[23] pin if GPIO[23] is configured as an input (offset 320h[15]=0)	Yes	Set by GPIO[23]
8	GPIO[24] Input Data	RO	GPIO[24] Input Data Return 0 if GPIO[24] is configured as an output (offset 320h[17]=1) Return the state of GPIO[24] pin if GPIO[24] is configured as an input (offset 320h[17]=0)	Yes	Set by GPIO[24]
9	GPIO[25] Input Data	RO	GPIO[25] Input Data Return 0 if GPIO[25] is configured as an output (offset 320h[19]=1) Return the state of GPIO[25] pin if GPIO[25] is configured as an input (offset 320h[19]=0)	Yes	Set by GPIO[25]
10	GPIO[26] Input Data	RO	GPIO[26] Input Data Return 0 if GPIO[26] is configured as an output (offset 320h[21]=1) Return the state of GPIO[26] pin if GPIO[26] is configured as an input (offset 320h[21]=0)	Yes	Set by GPIO[26]
11	GPIO[27] Input Data	RO	GPIO[27] Input Data Return 0 if GPIO[27] is configured as an output (offset 320h[23]=1) Return the state of GPIO[27] pin if GPIO[27] is configured as an input (offset 320h[23]=0)	Yes	Set by GPIO[27]

BIT	FUNCTION	TYPE	DESCRIPTION	EEPROM/ I2C-SMBUS	DEFAULT
12	GPIO[28] Input Data	RO	GPIO[28] Input Data Return 0 if GPIO[28] is configured as an output (offset 320h[25]=1) Return the state of GPIO[28] pin if GPIO[28] is configured as an input (offset 320h[25]=0)	Yes	Set by GPIO[28]
13	GPIO[29] Input Data	RO	GPIO[29] Input Data Return 0 if GPIO[29] is configured as an output (offset 320h[27]=1) Return the state of GPIO[29] pin if GPIO[29] is configured as an input (offset 320h[27]=0)	Yes	Set by GPIO[29]
14	GPIO[30] Input Data	RO	GPIO[30] Input Data Return 0 if GPIO[30] is configured as an output (offset 320h[29]=1) Return the state of GPIO[30] pin if GPIO[30] is configured as an input (offset 320h[29]=0)	Yes	Set by GPIO[30]
15	GPIO[31] Input Data	RO	GPIO[31] Input Data Return 0 if GPIO[31] is configured as an output (offset 320h[31]=1) Return the state of GPIO[31] pin if GPIO[31] is configured as an input (offset 320h[31]=0)	Yes	Set by GPIO[31]
31:16	Reserved	RsvdP	Not support.	No	0000h

9.4.105 GPIO 0-15 OUTPUT DATA REGISTER – OFFSET 330h (Port 0 Only)

BIT	FUNCTION	TYPE	DESCRIPTION	EEPROM/ I2C-SMBUS	DEFAULT
0	GPIO[0] Output Data	RW	GPIO[0] Output Data The value written to this bit is driven to GPIO[0] output if GPIO[0] is configured as an output (offset 31Ch[1]=1)	Yes	0
1	GPIO[1] Output Data	RW	GPIO[1] Output Data The value written to this bit is driven to GPIO[1] output if GPIO[1] is configured as an output (offset 31Ch[3]=1)	Yes	0
2	GPIO[2] Output Data	RW	GPIO[2] Output Data The value written to this bit is driven to GPIO[2] output if GPIO[2] is configured as an output (offset 31Ch[5]=1)	Yes	0
3	GPIO[3] Output Data	RW	GPIO[3] Output Data The value written to this bit is driven to GPIO[3] output if GPIO[3] is configured as an output (offset 31Ch[7]=1)	Yes	0
4	GPIO[4] Output Data	RW	GPIO[4] Output Data The value written to this bit is driven to GPIO[4] output if GPIO[4] is configured as an output (offset 31Ch[9]=1)	Yes	0
5	GPIO[5] Output Data	RW	GPIO[5] Output Data The value written to this bit is driven to GPIO[5] output if GPIO[5] is configured as an output (offset 31Ch[11]=1)	Yes	0
6	GPIO[6] Output Data	RW	GPIO[6] Output Data The value written to this bit is driven to GPIO[6] output if GPIO[6] is configured as an output (offset 31Ch[13]=1)	Yes	0
7	GPIO[7] Output Data	RW	GPIO[7] Output Data The value written to this bit is driven to GPIO[7] output if GPIO[7] is configured as an output (offset 31Ch[15]=1)	Yes	0
8	GPIO[8] Output Data	RW	GPIO[8] Output Data The value written to this bit is driven to GPIO[8] output if GPIO[8] is configured as an output (offset 31Ch[17]=1)	Yes	0
9	GPIO[9] Output Data	RW	GPIO[9] Output Data The value written to this bit is driven to GPIO[9] output if GPIO[9] is configured as an output (offset 31Ch[19]=1)	Yes	0
10	GPIO[10] Output Data	RW	GPIO[10] Output Data The value written to this bit is driven to GPIO[10] output if GPIO[10] is configured as an output (offset 31Ch[21]=1)	Yes	0
11	GPIO[11] Output Data	RW	GPIO[11] Output Data The value written to this bit is driven to GPIO[11] output if GPIO[11] is configured as an output (offset 31Ch[23]=1)	Yes	0
12	GPIO[12] Output Data	RW	GPIO[12] Output Data The value written to this bit is driven to GPIO[12] output if GPIO[12] is configured as an output (offset 31Ch[25]=1)	Yes	0
13	GPIO[13] Output Data	RW	GPIO[13] Output Data The value written to this bit is driven to GPIO[13] output if GPIO[13] is configured as an output (offset 31Ch[27]=1)	Yes	0

BIT	FUNCTION	TYPE	DESCRIPTION	EEPROM/ I2C-SMBUS	DEFAULT
14	GPIO[14] Output Data	RW	GPIO[14] Output Data The value written to this bit is driven to GPIO[14] output if GPIO[14] is configured as an output (offset 31Ch[29]=1)	Yes	0
15	GPIO[15] Output Data	RW	GPIO[15] Output Data The value written to this bit is driven to GPIO[15] output if GPIO[15] is configured as an output (offset 31Ch[31]=1)	Yes	0
31:16	Reserved	RsvdP	Not support.	No	0000h

9.4.106 GPIO 16-31 OUTPUT DATA REGISTER – OFFSET 334h (Port 0 Only)

BIT	FUNCTION	TYPE	DESCRIPTION	EEPROM/ I2C-SMBUS	DEFAULT
0	GPIO[16] Output Data	RW	GPIO[16] Output Data The value written to this bit is driven to GPIO[16] output if GPIO[16] is configured as an output (offset 320h[1]=1)	Yes	0
1	GPIO[17] Output Data	RW	GPIO[17] Output Data The value written to this bit is driven to GPIO[17] output if GPIO[17] is configured as an output (offset 320h[3]=1)	Yes	0
2	GPIO[18] Output Data	RW	GPIO[18] Output Data The value written to this bit is driven to GPIO[18] output if GPIO[18] is configured as an output (offset 320h[5]=1)	Yes	0
3	GPIO[19] Output Data	RW	GPIO[19] Output Data The value written to this bit is driven to GPIO[19] output if GPIO[19] is configured as an output (offset 320h[7]=1)	Yes	0
4	GPIO[20] Output Data	RW	GPIO[20] Output Data The value written to this bit is driven to GPIO[20] output if GPIO[20] is configured as an output (offset 320h[9]=1)	Yes	0
5	GPIO[21] Output Data	RW	GPIO[21] Output Data The value written to this bit is driven to GPIO[21] output if GPIO[21] is configured as an output (offset 320h[11]=1)	Yes	0
6	GPIO[22] Output Data	RW	GPIO[22] Output Data The value written to this bit is driven to GPIO[22] output if GPIO[22] is configured as an output (offset 320h[13]=1)	Yes	0
7	GPIO[23] Output Data	RW	GPIO[23] Output Data The value written to this bit is driven to GPIO[23] output if GPIO[23] is configured as an output (offset 320h[15]=1)	Yes	0
8	GPIO[24] Output Data	RW	GPIO[24] Output Data The value written to this bit is driven to GPIO[24] output if GPIO[24] is configured as an output (offset 320h[17]=1)	Yes	0
9	GPIO[25] Output Data	RW	GPIO[25] Output Data The value written to this bit is driven to GPIO[25] output if GPIO[25] is configured as an output (offset 320h[19]=1)	Yes	0
10	GPIO[26] Output Data	RW	GPIO[26] Output Data The value written to this bit is driven to GPIO[26] output if GPIO[26] is configured as an output (offset 320h[21]=1)	Yes	0
11	GPIO[27] Output Data	RW	GPIO[27] Output Data The value written to this bit is driven to GPIO[27] output if GPIO[27] is configured as an output (offset 320h[23]=1)	Yes	0
12	GPIO[28] Output Data	RW	GPIO[28] Output Data The value written to this bit is driven to GPIO[28] output if GPIO[28] is configured as an output (offset 320h[25]=1)	Yes	0
13	GPIO[29] Output Data	RW	GPIO[29] Output Data The value written to this bit is driven to GPIO[29] output if GPIO[29] is configured as an output (offset 320h[27]=1)	Yes	0
14	GPIO[30] Output Data	RW	GPIO[30] Output Data The value written to this bit is driven to GPIO[30] output if GPIO[30] is configured as an output (offset 320h[29]=1)	Yes	0
15	GPIO[31] Output Data	RW	GPIO[31] Output Data The value written to this bit is driven to GPIO[31] output if GPIO[31] is configured as an output (offset 320h[31]=1)	Yes	0
31:16	Reserved	RsvdP	Not support.	No	0000h

9.4.107 GPIO 0-31 INTERRUPT POLARITY REGISTER – OFFSET 338h (Port 0 Only)

BIT	FUNCTION	TYPE	DESCRIPTION	EEPROM/ I2C-SMBUS	DEFAULT
31:0	GPIO Interrupt Polarity	RW	Controls whether GPIO Interrupt input is Active-Low or Active-High for the corresponding GPIOx signal. Bit[31:0] correspond to GPIO[31:0], respectively. 0b: GPIO Interrupt input is Active-Low 1b: GPIO Interrupt input is Active-High	Yes	0000_0000h

9.4.108 GPIO 0-31 INTERRUPT STATUS REGISTER – OFFSET 33Ch (Port 0 Only)

BIT	FUNCTION	TYPE	DESCRIPTION	EEPROM/ I2C-SMBUS	DEFAULT
31:0	GPIO Interrupt Status	RO	Indicates whether GPIO interrupt are inactive or active for the corresponding GPIOx signal. Bit[31:0] correspond to GPIO[31:0] respectively. 0b: GPIO interrupt is inactive 1b: GPIO interrupt is active	No	0000_0000h

9.4.109 GPIO 0-31 INTERRUPT MASK REGISTER – OFFSET 340h (Port 0 Only)

BIT	FUNCTION	TYPE	DESCRIPTION	EEPROM/ I2C-SMBUS	DEFAULT
31:0	GPIO Interrupt Mask	RW	Indicates whether GPIO interrupts are masked or not masked for the corresponding GPIOx signal. Bit[31:0] correspond to GPIO[31:0], respectively. 0b: GPIO interrupt is unmasked 1b: GPIO interrupt is masked	Yes	0000_0000h

9.4.110 OPERATION MODE REGISTER – OFFSET 348h (Port 0 Only)

BIT	FUNCTION	TYPE	DESCRIPTION	EEPROM/ I2C-SMBUS	DEFAULT
2:0	Reserved	RsvdP	Not support.	No	000b
5:3	pkgssel	RO	Package Bonding option.	No	001b
8:6	portcfg	RO	Port/lane configuration settins. 001b: 2 x4 ports 010b: 1 x4, 2 x2 ports 011b: 4 x2 ports 100b: 1 x4, 4 x1 ports 101b: 8 x1 ports Others: Reserved	No	Set by PORTCFG [2:0]
10:9	chipmode	RO	Chip operation mode selection. 00b: Normal mode 01b: iddq/mbist mode 10b: AC JTAG mode 11b: phy_mode	No	Set by CHIPMODE [1:0]
12:11	Reserved	RsvdP	Not support.	No	00b
13	ckmode	RO	Reference clock modes. strap pin. 0b: base mode 1b: CDEP separate reference mode	No	Set by CKMODE
14	dma_mode	RO	0b: disable DMA 1b: enable DMA	No	0
20:15	upport_sel	RO	Upstream port selection.	No	0000_00b
21	CDEP_mode	RO	0b: disable CDEP 1b: enable CDEP	No	1
22	scan_tm	RO	0b: normal mode 1b: scan mode	No	0

BIT	FUNCTION	TYPE	DESCRIPTION	EEPROM/ I2C-SMBUS	DEFAULT
23	hotplug_pin_en	RO	0b: GPIO[31:0] are GPIO pins 1b: GPIO[31:0] are used as hot plug pins	No	Set by HOT_PLUG_EN_L
24	surprise_hp_en	RO	0b: disable surprise hot-plug 1b: enable surprise hot-plug	No	Set by SURPRISE_HP
25	ioe_40bit_en	RO	0b: support 16 bit IOE 1b: support 40 bit IOE	No	0
26	clkbuf_pd	RO	0b: clock buffer is in normal mode 1b: clock buffer is in power down mode	No	Set by CLKBUFPD_L
27	pm_l1_1_en	RO	0b: GPIO[15:8] are GPIO pins 1b: GPIO[15:8] are used as CLKREQ_L[7:0]	No	Set by PM_L11_EN_L
30:28	i2c/smaddr_out	RO	Indicate I2C/SMBUS address[2:0].	No	Set by I2C_ADDRESS[2:0]
31	Reserved	RsvdP	Not Support.	No	1

9.4.111 CLOCK BUFFER CONTROL REGISTER – OFFSET 34Ch (Port 0 Only)

BIT	FUNCTION	TYPE	DESCRIPTION	EEPROM/ I2C-SMBUS	DEFAULT
7:0	Clock OE Control	RW	0b... disable clock output 1b... enable clock output	Yes	FFh
8	Clock Power Down	RW	Used to set CLKBUFPD_L strap pin. 0b... power on 1b... power down	Yes	Set by CLKBUFPD_L
9	Control Enable	RW	0b... disable to use this register control clock buffer output 1b... enable to use this register control clock buffer output	Yes	0
10	Clock Source Sel	RW	0b... input clock buffer source is from differential clock pad 1b... input clock buffer source is from CMOS single end clock source	Yes	Set by CLKBUF_CMOS_EN_L
23:11	Reserved	RsvdP	Not support.	No	0_0h
31:24	Revision ID	RO	Revision id.	No	00h

9.4.112 LTSSM CSR 0 REGISTER – OFFSET 380h

BIT	FUNCTION	TYPE	DESCRIPTION	EEPROM/ I2C-SMBUS	DEFAULT
3:0	eq_preset_uplimited_0	RW	Define EQ evaluate upper limiter range of preset for Lane 0.	Yes	Ah
7:4	eq_preset_dnlimited_0	RW	Define EQ evaluate down limiter range of preset for Lane 0.	Yes	5h
11:8	eq_preset_uplimited_1	RW	Define EQ evaluate upper limiter range of preset for Lane 1.	Yes	Ah
15:12	eq_preset_dnlimited_1	RW	Define EQ evaluate down limiter range of preset for Lane 1.	Yes	5h
19:16	eq_preset_uplimited_2	RW	Define EQ evaluate upper limiter range of preset for Lane 2. If Lane 2 does not exist on this port, the register is reserved with a default value of 0h.	Yes	Ah
23:20	eq_preset_dnlimited_2	RW	Define EQ evaluate down limiter range of preset for Lane 2. If Lane 2 does not exist on this port, the register is reserved with a default value of 0h.	Yes	5h
27:24	eq_preset_uplimited_3	RW	Define EQ evaluate upper limiter range of preset for Lane 3. If Lane 3 does not exist on this port, the register is reserved with a default value of 0h.	Yes	Ah

BIT	FUNCTION	TYPE	DESCRIPTION	EEPROM/ I2C-SMBUS	DEFAULT
31:28	eq_preset_dnlmited_3	RW	Define EQ evaluate down limiter range of preset for Lane 3. If Lane 3 does not exist on this port, the register is reserved with a default value of 0h.	Yes	5h

9.4.113 LTSSM CSR 1 REGISTER – OFFSET 384h

BIT	FUNCTION	TYPE	DESCRIPTION	EEPROM/ I2C-SMBUS	DEFAULT
3:0	eq_preset_uplimited_4	RW	Define EQ evaluate upper limiter range of preset for Lane 4. If Lane 4 does not exist on this port, the register is reserved with a default value of 0h.	Yes	Ah
7:4	eq_preset_dnlmited_4	RW	Define EQ evaluate down limiter range of preset for Lane 4. If Lane 4 does not exist on this port, the register is reserved with a default value of 0h.	Yes	5h
11:8	eq_preset_uplimited_5	RW	Define EQ evaluate upper limiter range of preset for Lane 5. If Lane 5 does not exist on this port, the register is reserved with a default value of 0h.	Yes	Ah
15:12	eq_preset_dnlmited_5	RW	Define EQ evaluate down limiter range of preset for Lane 5. If Lane 5 does not exist on this port, the register is reserved with a default value of 0h.	Yes	5h
19:16	eq_preset_uplimited_6	RW	Define EQ evaluate upper limiter range of preset for Lane 6. If Lane 6 does not exist on this port, the register is reserved with a default value of 0h.	Yes	Ah
23:20	eq_preset_dnlmited_6	RW	Define EQ evaluate down limiter range of preset for Lane 6. If Lane 6 does not exist on this port, the register is reserved with a default value of 0h.	Yes	5h
27:24	eq_preset_uplimited_7	RW	Define EQ evaluate upper limiter range of preset for Lane 7. If Lane 7 does not exist on this port, the register is reserved with a default value of 0h.	Yes	Ah
31:28	eq_preset_dnlmited_7	RW	Define EQ evaluate down limiter range of preset for Lane 7. If Lane 7 does not exist on this port, the register is reserved with a default value of 0h.	Yes	5h

9.4.114 LTSSM CSR 2 REGISTER – OFFSET 388h

BIT	FUNCTION	TYPE	DESCRIPTION	EEPROM/ I2C-SMBUS	DEFAULT
3:0	eq_preset_uplimited_8	RW	Define EQ evaluate upper limiter range of preset for Lane 8. If Lane 8 does not exist on this port, the register is reserved with a default value of 0h.	Yes	Ah
7:4	eq_preset_dnlmited_8	RW	Define EQ evaluate down limiter range of preset for Lane 8. If Lane 8 does not exist on this port, the register is reserved with a default value of 0h.	Yes	5h
11:8	eq_preset_uplimited_9	RW	Define EQ evaluate upper limiter range of preset for Lane 9. If Lane 9 does not exist on this port, the register is reserved with a default value of 0h.	Yes	Ah
15:12	eq_preset_dnlmited_9	RW	Define EQ evaluate down limiter range of preset for Lane 9. If Lane 9 does not exist on this port, the register is reserved with a default value of 0h.	Yes	5h
19:16	eq_preset_uplimited_10	RW	Define EQ evaluate upper limiter range of preset for Lane 10. If Lane 10 does not exist on this port, the register is reserved with a default value of 0h.	Yes	Ah
23:20	eq_preset_dnlmited_10	RW	Define EQ evaluate down limiter range of preset for Lane 10. If Lane 10 does not exist on this port, the register is reserved with a default value of 0h.	Yes	5h
27:24	eq_preset_uplimited_11	RW	Define EQ evaluate upper limiter range of preset for Lane 11. If Lane 11 does not exist on this port, the register is reserved with a default value of 0h.	Yes	Ah
31:28	eq_preset_dnlmited_11	RW	Define EQ evaluate down limiter range of preset for Lane 11. If Lane 11 does not exist on this port, the register is reserved with a default value of 0h.	Yes	5h

9.4.115 LTSSM CSR 3 REGISTER – OFFSET38Ch

BIT	FUNCTION	TYPE	DESCRIPTION	EEPROM/ I2C-SMBUS	DEFAULT
3:0	eq_preset_uplimited_8	RW	Define EQ evaluate upper limiter range of preset. This value is defined per lane.	Yes	Ah
7:4	eq_preset_dnlimited_8	RW	Define EQ evaluate down limiter range of preset. This value is defined per lane.	Yes	5h
11:8	eq_preset_uplimited_9	RW	Define EQ evaluate upper limiter range of preset. This value is defined per lane.	Yes	Ah
15:12	eq_preset_dnlimited_9	RW	Define EQ evaluate down limiter range of preset. This value is defined per lane.	Yes	5h
19:16	eq_preset_uplimited_10	RW	Define EQ evaluate upper limiter range of preset. This value is defined per lane.	Yes	Ah
23:20	eq_preset_dnlimited_10	RW	Define EQ evaluate down limiter range of preset. This value is defined per lane.	Yes	5h
27:24	eq_preset_uplimited_11	RW	Define EQ evaluate upper limiter range of preset. This value is defined per lane.	Yes	Ah
31:28	eq_preset_dnlimited_11	RW	Define EQ evaluate down limiter range of preset. This value is defined per lane.	Yes	5h

9.4.116 LTSSM 0 REGISTER – OFFSET 390h

BIT	FUNCTION	TYPE	DESCRIPTION	EEPROM/ I2C-SMBUS	DEFAULT
1:0	det_times	RW	Used to set how many detect times will LTSSM execute. Max times =3 and Mini times is 1.	Yes	11b
2	force2detect	RW	Force LTSSM state stay in detect state.	Yes	0
3	force2compliance	RW	Force LTSSM send compliance pattern.	Yes	0
5:4	force_comp_rate	RW	Force LTSSM compliance in forced compliance mode.	Yes	00b
9:6	force_comp_deep_preset	RW	Force LTSSM GEN3 compliance mode's preset value.	Yes	0h
10	comp_parity_en	RW	Force GEN 1/GEN2 compliance parity. Debug only.	Yes	0
11	force2loop	RW	Force LTSSM to loopback mode	Yes	0
12	upconfig_capable	RW	Enable upconfig capability	Yes	0
13	lane_disable	RW	1: lane will be disable when it is a unused lane.	Yes	0
17:14	sh_reset_time_sel	RW	Assert reset period on hot plug power on/power off sequence. 00b: 100 ms 01b: 300 ms 10b: 500 ms 11b: 600 ms	Yes	3h
19:18	Reserved	RsvdP	Not support.	No	00b
27:20	tx_nfts_num	RW	NFTS NUMBER.	Yes	F0h
28	Reserved	RsvdP	Not support.	No	0
29	chg_ln_width	RW	Enable change link width	Yes	0
30	up_speed_ctrl_chx	RW	Enable upstream port speed change when DL_UP in GEN 3 speed.	Yes	0
31	ltssm_debug_sel	RW	0b: the output of offset 734h is for embedded LA 1b: the output of offset 734h is for LTSSM flow	Yes	1

9.4.117 LTSSM 1 REGISTER – OFFSET 394h

BIT	FUNCTION	TYPE	DESCRIPTION	EEPROM/ I2C-SMBUS	DEFAULT
1:0	recv_eq_process_sel	RW	EQ evaluated mode. Debug only.	Yes	01b
2	comp_recv_bit_set	RW	Send compliance receive bit in loopback mode.	Yes	0
3	mrlpdc_ctrl_in	RW	Enable D3 dilink function	Yes	0
8:4	eq_eval_time	RW	Evaluate process timer selection. Debug only.	Yes	0_0000b
10:9	mrlpdc_tmr_sel	RW	When D3 dlink function is enable. This timer set PDC enable time.	Yes	00b
11	enter_loop_back	RW	LOOPBACK master enable.	Yes	0
12	infer_eidle_en	RW	Enable infer eidle function.	Yes	1
13	aspm_nack_en	RW	Enable response NACK Message when ASPM L1 DLLP request.	Yes	0
14	Hp_hot_ctr_en_reg	RW	Force mrlpdc =0. Debug only	Yes	0
15	Hp_hot_clk_en_reg	RW	Enable clock buffer. Colock do not control by SHP control.	Yes	0

BIT	FUNCTION	TYPE	DESCRIPTION	EEPROM/ I2C-SMBUS	DEFAULT
19:16	Reserved	RsvdP	Not support.	No	0h
23:20	any_phy_sts	RW	Control physts align time. Internal used only.	Yes	0h
31:24	ltssm_debug_sel	RW	Internal used only.	Yes	00h

9.4.118 LTSSM 2 REGISTER – OFFSET 398h

BIT	FUNCTION	TYPE	DESCRIPTION	EEPROM/ I2C-SMBUS	DEFAULT
15:0	detect_timer_sel	RW	Define two ltssmtxdetect space. Debug only	Yes	0000h
23:16	sel_linkevalfigure	RW	Set good FOM value threshold	Yes	F0h
26:24	lane_good_sel	RW	Selection lane good condition. 00b: coefficient do not need change 01b: FOM!=00b and coefficient did not need change 10b: FOM=threshold or coefficient did not need change 11b: FOM=threshold and coefficient did not need change	Yes	000b
28:27	eidle_sel_reg	RW	1b: Use PHY generate electrical 0b: Use internal electrical	Yes	0
29	sh_extra_reset	RW	Internal used only.	Yes	0
30	ioe_addr_sel	RW	Use register setting register to match outside IOE address. 0b: internal 1b: register setting value	Yes	0
31	ioe_40	RW	1b: USE 40 pin IOE 0b: Use 16 pin IOE	Yes	0

9.4.119 LTSSM 3 REGISTER – OFFSET 39Ch

BIT	FUNCTION	TYPE	DESCRIPTION	EEPROM/ I2C-SMBUS	DEFAULT
6:0	cfg_address_in	RW	IOE address defined by register.	Yes	00h
7	hp_scl_clk_sel_in	RW	I2C clock rate. 0b: 62Khz 1b: 31Khz	Yes	0
15:8	aspm_l1_cnt_num	RW	Accumulated 10s number to enter ASPM l1 condition.	Yes	08h
31:16	aspm_l1	RW	ASPM L1 idle timer.	Yes	0FFh

9.4.120 LTSSM 4 REGISTER – OFFSET 3A0h

BIT	FUNCTION	TYPE	DESCRIPTION	EEPROM/ I2C-SMBUS	DEFAULT
15:0	tx_swing	RW	TX swing setting by register value.	Yes	0000h
17:16	eios_cnt	RW	Polling compliance exit condition.	Yes	1
18	bypass_detect	RW	Ignore LTSSM detect result and use max lane width.	Yes	0
19	detection_option	RW	1b: use detection result 0b: use modify detection result	Yes	0
20	stand_by	RW	Used to control whether the PHY rx is active when PHY is in P0 or P0s. 1b: Active 0b: Standby	Yes	0
21	in_progress	RW	Set rxqprocess behavior. Internal used only.	Yes	0
22	deskew_rxeqval	RW	Set deskew behavior in EQ period. Internal used only.	Yes	0
23	ltssm_cfg2loop_sel	RW	Cfg go to loopback condition. 0b : see any loopback bit 1b: see all loopback bit. Internal used only.	Yes	0
27:24	recv_eq_optionl	RW	Eq_option. bit[0]... set eq_valid =1	Yes	001b
31:28	ltssm_cfg_reversal	RW	Select reversal condition. Internal used only.	Yes	0

9.4.121 LTSSM 5 REGISTER – OFFSET 3A4h

BIT	FUNCTION	TYPE	DESCRIPTION	EEPROM/ I2C-SMBUS	DEFAULT
15:0	tskp_gen1_n0_reg	RW	When sris support, use this skip value.	Yes	004Bh
31:16	skp_gen1_reg	RW	When sris disable, use the skip value.	Yes	0258h

9.4.122 LTSSM 6 REGISTER – OFFSET 3A8h

BIT	FUNCTION	TYPE	DESCRIPTION	EEPROM/ I2C-SMBUS	DEFAULT
15:0	tskp_gen3_n0_reg	RW	When sris support, use this skip value.	Yes	011Ch
31:16	tskp_gen3_reg	RW	When sris disable, use the skip value.	Yes	0BBEh

9.4.123 LTSSM 7 REGISTER – OFFSET 3ACh

BIT	FUNCTION	TYPE	DESCRIPTION	EEPROM/ I2C-SMBUS	DEFAULT
4:0	ltssm_rx_mask_reg	RW	bit[0]... mask hot reset bit bit[1]... mask disable bit bit[2]... mask loopback bit bit[3]... mask disable scrambling bit bit[4]... mask compliance bit	Yes	0_0000b
5	ltssm_port_split_ctr_reg	RW	0b: enable port split 1b: disable port split	Yes	0
9:6	ltssm_lg_idle_cnt_reg	RW	Used to set idle data receive date number.	Yes	6h
10	ltssm_chg_rate_ms_reg	RW	Used to control down port change rate as a master.	Yes	0
11	gpio_in_reg_tmp	RW	In external I2C IOE bit[6],it is GPIO bit.	Yes	0
15:12	ltssm_config_rev_num_reg	RW	bit[1:0]... cfg.linkaccept to cfg.linkwait couter selection. bit[3:2]... cfg.lanenum to cfg.cpl counter selection	Yes	0000b
16	ltssm_config_delay_cnt_reg	RW	cfg.start delay time to cfg.linkaccept. Use this delay time to decide partial lane detection.	Yes	0
17	disable_cfg_lane_chg_reg	RW	disable cfg.linkaccept state change lane.	Yes	0
18	disable_cfg_lane_time_reg	RW	disable cfg.lanenum to detect state.	Yes	0
22:19	partial_lane_sel_reg	RW	bit[1:0]... decide partial lane reverse bit[2]... reserved bit[3]... delay cfg.start to cfg.linaccept sate for cross link	Yes	0001b
23	enable_bacon_l2_reg	RW	Used to enable L2 send beacon signal.	Yes	0
24	Reserved	RsvdP	Not support.	No	0
26:25	lane_change_ctr_reg	RW	Used to control lane number change in cfg state.	Yes	00b
28:27	poll_exit_comp_cnt_reg	RW	Used to set poll.compliance exit counter.	Yes	11b
29	led_mode_prsnt_sel_reg	RW	Used to select present detect pin come from IOE or IO pin in surprise mode.	Yes	1
30	shp_rest_ctr_reg	RW	Used to control ip_core reset pin come from reset_top or shp generation. 0b: come from shp generation 1b: come from reset_top	Yes	0
31	always_wait_linkup_reg	RW	In shp control,shp try to link up device always.	Yes	0

9.4.124 LTSSM 8 REGISTER – OFFSET 3B0h

BIT	FUNCTION	TYPE	DESCRIPTION	EEPROM/ I2C-SMBUS	DEFAULT
0	dpc_error_latch	RW	When dpc error occurs, ltssm will entry to disable state. 0b: dpc error signal will be latched until ltssm go to disable state. 1b: dpc error signal will not be latched.	Yes	1
1	any_phy_sts_tmp_sel_reg	RW	0b: come from all phy_sts 1b: combine with lane detetion.	Yes	0
5:2	cfg_stat_ctr_reg	RW	cfg_start option selection.	Yes	0000b
19:6	rate_chg_ctr_reg	RW	Used to control rate change behavior.	Yes	0-0b
23:20	loop_test_ctr_reg	RW	loop test behavior control.	Yes	0h
25:24	l0_power_dn_wait_t_reg	RW	When receive/transmitter eos, pm control wait 50 cycle time to L1/l0s/L2. 00b: 50 01b: 1Fh 10b: FFh 11b: FFFFh	Yes	00b
26	gen3_phy_pm_idle_control_reg	RW	0b: use rxidle in PM 1b: ignore rxidle in PM	Yes	0
27	eq1to0_eval_reg	RW	0b: disble skip eq23 1b: skip eq23	Yes	0
30:28	debunce_sel_reg	RW	bit[1:0]... attention button/present detection de-bounce timer. 00b: C00h 01b: FFFh 10b: 600h 11b: 0FFh Bit[2]... de-bounce enable	Yes	100b
31	Reserved	RsvdP	Not support	No	0

9.4.125 LTSSM 9 REGISTER – OFFSET 3B4h

BIT	FUNCTION	TYPE	DESCRIPTION	EEPROM/ I2C-SMBUS	DEFAULT
0	clear_rx_sts_err_counter	WO	Reading returns 0 always. Writing 1 will celar rx status error counter.	Yes	0
1	redo_eq_ctrl	RW	1b: redo eq when rx error > static_counter set by bit[15:8] in GEN3	Yes	0
2	static_enable_reg	RW	1b: enable perform downstream port eq when error	Yes	0
3	perform_eq_err_reg	RW	1b: when rx error occurred enable to perform redo eq 0b: disable	Yes	0
4	static_enable_up_reg	RW	1b: enable up port execute eq when rx error count > static_counter set by bit[15:8]	Yes	0
7:5	Reserved	RsvdP	Not support.	No	000b
15:8	static_ctrl_sel_num	RW	Used to set static_counter.	Yes	01h
31:16	rx_sts_err_counter	RO	Reading returns rx status error counter value. Writing this register will result in undefined behavior.	No	0000h

9.4.126 LTSSM 10 REGISTER – OFFSET 3B8h

BIT	FUNCTION	TYPE	DESCRIPTION	EEPROM/ I2C-SMBUS	DEFAULT
19:0	CLKREQ_L Wait Time	RW	Once entering L1.1 power state, the port will deassert CLKREQ_L immediately. However, CLKREQ_L signal is an open-drain wire-or signal with the link partner. If the link partner does not deassert CLKREQ_L for a certain period of time, which is defined by CLKREQ_L Wait Time, the port will assert CLKREQ_L again to resume back to L1 state. The CLKREQ_L wait time decides how long the switch will wait for CLKREQ_L being deasserted by the link partner. The unit is “10 ns”. Reset to F_FF00h. It is about 10 ms.	Yes	F_FF00h
20	up_entry_l1.1	RW	0b: enable up port can entry to L1.1	Yes	0
21	dn_entry_l1.1	RW	0b: enable down port can entry to L1.1	Yes	0
31:22	Reserved	RsvdP	Not support.	No	000h

9.4.127 LTSSM 11 REGISTER – OFFSET 3BCh

BIT	FUNCTION	TYPE	DESCRIPTION	EEPROM/ I2C-SMBUS	DEFAULT
0	hp_scl_clk_sel_in_dly_tmp	RW	Used to set hp_i2c delay counter.	Yes	0
2:1	recv_tor_ts12_num_reg	RW	Used to set receive change bit number that fire rec.cfg change to rec.speed.	Yes	10b
3	poll_exit_comp_cnt_sel_reg	RW	Used to control poll.compliance exit.	Yes	0
6:4	loop_test_ctr_eios_reg	RW	Used to set receive eios number in loop.exit state.	Yes	010b
7	shp_command_dis_em_reg	RW	Used to check electromechanical control combine with set slot command.	Yes	0
15:8	pm_phy_rxeidle_cnt_sel_reg	RW	Used to control Pm phy rxeidle counter.	Yes	01h
31:16	cfg_cnt_ctr_reg	RW	Used to control ltssm cfg state.	Yes	9C49h

9.4.128 LTSSM 12 REGISTER – OFFSET 3C0h

BIT	FUNCTION	TYPE	DESCRIPTION	EEPROM/ I2C-SMBUS	DEFAULT
0	dis_ini_hw_dis	RW	0b: disable hardware autonomous speed bit in link control 2 register 1b: enable	Yes	0
1	up_hot_reset	RW	0b: upstream port does not send hot reset go through recovery 1b: upstream port send hot reset go through recovery	Yes	0
2	rev_ext	RW	When enable it, pm will check recovery state and pm state is 0 then exit to L0.	Yes	0
3	rev_ext1	RW	When enable it, ltssm check rxeidle in ltssm L1 state. If rxeidle is low, ltssm L1 will jump to L0.	Yes	0
7:4	par_eidle_sel	RW	bit[0]: when set, ignore fts packet to generate gen3 rxeidle. bit[1]: when set, ignore ts1 packet to generate gen3 rxeidle. bit[2]: when set, ignore ts2 packet to generate gen3 rxeidle. bit[3]: when set, ignore eios packet to generate gen3 rxeidle.	Yes	1000b
15:8	l1_rev_ext1_cnt	RW	When wire l1_rev_ext1_reg is enabled, the counter use to evaluate high for rxeidle.	Yes	1Fh
23:16	pm_phy_rxeidle_cnt_sel1_reg	RW	Stay in L1 counter; L1 to L0 counter. It makes sure all conditions are meet. It is used for test mode only.	Yes	06h
24	ack_nak_empty_o_reg	RW	0b: check ack or nack is empty when L0 to L1. 1b: do not check ack or nack is empty when L0 to L1.	Yes	0
25	eq_start_ctrl_reg	RW	0b: get coefficient do not check whether state in eq state. 1b: get coefficient check whether state in eq state.	Yes	0

BIT	FUNCTION	TYPE	DESCRIPTION	EEPROM/ I2C-SMBUS	DEFAULT
26	dis_change_rate_coef_reg	RW	0b: enable change lane width change function. 1b: disable lane width change function.	Yes	0
28:27	eios_ctrl_reg_0	RW	Used to check receive eios counter in change rate stage.	Yes	00b
31:29	eios_ctrl_reg_1	RW	Used to send eios number in change rate.	Yes	100b

9.4.129 LTSSM 13 REGISTER – OFFSET 3C4h

BIT	FUNCTION	TYPE	DESCRIPTION	EEPROM/ I2C-SMBUS	DEFAULT
7:0	transmit idle data number[7:0]	RW	Used to set transmit idle data number.	Yes	08h
11:8	receive idle data[3:0]	RW	Used to set receive idle data.	Yes	8h
12	disable_pol2loop_reg	RW	0b: enable pol2loop 1b: disable pol2loop	Yes	0
14:13	Reserved	RsvdP	Not support.	No	10b
15	Forced to Gen 3	RW	Forced the downstream port trying to link at Gen 3 speed if the link partner reporting Gen 3 link capability. 0b: No trying (i.e. linked at whatever speed per standard flow) 1b: Keep trying to change rate to Gen 3 until success	Yes	0
23:16	cfg_ctrl_sub_reg [7:0]	RW	Used to set cfg_ctrl_sub register.	Yes	06h
25:24	rate_eq_ctr2_reg [1:0]	RW	Used to set rate_eq_ctr2 register.	Yes	00b
29:26	eq_done_8g_ctr_reg[3:0]	RW	Used to set eq_done_8g_ctrl register.	Yes	0110b
31:30	up_have_rcv_eq1_reg[1:0]	RW	Used to set up_have_rcv_eq1 register.	Yes	00b

9.4.130 LTSSM 14 REGISTER – OFFSET 3C8h

BIT	FUNCTION	TYPE	DESCRIPTION	EEPROM/ I2C-SMBUS	DEFAULT
3:0	lane_sel_cnt	RW	Select lane preset which eq negotiate result.	Yes	0h
7:4	sphp_ctrl_reg	RW	Serial hot plug controller for power control option 0.	Yes	0h
9:8	pme_to_ack_timer_reg	RW	Pme to ack response timer selection.	Yes	00b
10	send_pack_on_time_reg	RW	Send link up/all port enter idle message to main tie at fixed time.	Yes	0
19:11	disable_eios_reg	RW	Pm idle option.	Yes	0-0b
20	diable_hot_reset_reg	RW	0b: hotreset state send ts1 after sds send at recovery state 1b: hotreset state send ts1 directly	Yes	0
23:21	recovery_idle_count	RW	Used to configure recovery idle send amount of additional idle symbol number.	Yes	000b
27:24	eq_number_ask	RO	EQ number that DUT ask number to link partner.	No	0h
31:28	eq_number_applied	RO	EQ number that come from link partner.	No	0h

9.4.131 LTSSM 15 REGISTER – OFFSET 3CCh

BIT	FUNCTION	TYPE	DESCRIPTION	EEPROM/ I2C-SMBUS	DEFAULT
0	pwr_det_ctrl	RW	Used to enable power saing function at empty port. 0b: disable power saving function at empty port 1b: enable power saving function at empty port	Yes	0
1	recovery_ctrl	RW	When set 1, entry to recovery will ignore rx is in L0s.	Yes	0
2	fake_oder_set_done	RW	When set 1, ltssm will auto generate order set done sinal when ltssm set pipe_tx_os signal large than ff cycle time.	Yes	0
3	disable_skip_at_10	RW	When set 1, send skip signal will extend until send skip packet done.	Yes	0
7:4	disable_reject	RW	Used to control reject bit behavior on ts order set at eq process.	Yes	0h
23:8	comp_ctrl_gen1/2	WO	Used to control compliance pattern behavior on gen1/gen2.	Yes	0000h

BIT	FUNCTION	TYPE	DESCRIPTION	EEPROM/ I2C-SMBUS	DEFAULT
31:24	Reserved	RsvdP	Not support.	No	00h

9.4.132 DLL CSR 0 REGISTER – OFFSET 420h

BIT	FUNCTION	TYPE	DESCRIPTION	EEPROM/ I2C-SMBUS	DEFAULT
11:0	GEN1_ACK_LATENCY_CTRL	RW	bit[11]: user enable bit[10:0]: user define ACK latency value	Yes	800h
15:12	Reserved	RsvdP	Not support.	No	0h
16	BLOCK_BUMP_DET	RO	Block list has been overrun.	No	0
27:17	Reserved	RsvdP	Not support.	No	0_0b
28	TLP_NO_EOF_ERR_DFT	RO	Detecting TLP has no end of frame.	No	0
29	TLP_HEADER_ERR_DET	RO	Detecting header of TLP is wrong.	No	0
30	FIFO_LTH_ERR_ABORT_DET	RO	Detecting total length of TLP is abort.	No	0
31	FIFO_LTH_ERR_DET	RO	Detecting total length of TLP is wrong.	No	0

9.4.133 DLL CSR 1 REGISTER – OFFSET 424h

BIT	FUNCTION	TYPE	DESCRIPTION	EEPROM/ I2C-SMBUS	DEFAULT
11:0	GEN2_ACK_LATENCY_CTRL	RW	bit[11]: user enable bit[10:0]: user define ACK latency value	Yes	800h
15:12	Reserved	RsvdP	Not support.	No	0h
16	BLOCK_BUMP_DET	RO	Block list has been overrun.	No	0
27:17	Reserved	RsvdP	Not support.	No	0_0b
28	TLP_NO_EOF_ERR_DFT	RO	Detecting TLP has no end of frame.	No	0
29	TLP_HEADER_ERR_DET	RO	Detecting header of TLP is wrong.	No	0
30	FIFO_LTH_ERR_ABORT_DET	RO	Detecting total length of TLP is abort.	No	0
31	FIFO_LTH_ERR_DET	RO	Detecting total length of TLP is wrong.	No	0

9.4.134 DLL CSR 2 REGISTER – OFFSET 428h

BIT	FUNCTION	TYPE	DESCRIPTION	EEPROM/ I2C-SMBUS	DEFAULT
11:0	GEN3_ACK_LATENCY_CTRL	RW	bit[11]: user enable bit[10:0]: user define ACK latency value	Yes	800h
15:12	Reserved	RsvdP	Not support.	No	0h
16	BLOCK_BUMP_DET	RO	Block list has been overrun.	No	0
27:17	Reserved	RsvdP	Not support.	No	0_0b
28	TLP_NO_EOF_ERR_DFT	RO	Detecting TLP has no end of frame.	No	0
29	TLP_HEADER_ERR_DET	RO	Detecting header of TLP is wrong.	No	0
30	FIFO_LTH_ERR_ABORT_DET	RO	Detecting total length of TLP is abort.	No	0
31	FIFO_LTH_ERR_DET	RO	Detecting total length of TLP is wrong.	No	0

9.4.135 DLL CSR 3 REGISTER – OFFSET 42Ch

BIT	FUNCTION	TYPE	DESCRIPTION	EEPROM/ I2C-SMBUS	DEFAULT
11:0	GEN1_REPLAY_TIMER_CTRL	RW	User defined replay timeout value for GEN1.	Yes	000h
12	User_define_GEN1_REPLAY_TIMER	RW	0b: disable user defined replay timer for GEN1 1b: enable user defined replay timer for GEN1	Yes	0b
21:13	retry buffer threshold for 128	RW	Used to set retry buffer threshold for 128 payload.	Yes	1F1h
30:22	retry buffer threshold for 256	RW	Used to set retry buffer threshold for 256 payload.	Yes	1F0h
31	tx ready non valid error by transaction layer	RW1C	For internal used.	Yes	0

9.4.136 DLL CSR 4 REGISTER – OFFSET 430h

BIT	FUNCTION	TYPE	DESCRIPTION	EEPROM/ I2C-SMBUS	DEFAULT
11:0	GEN2_REPLAY_TIMER_CTRL	RW	User defined replay timeout value for GEN2.	Yes	000h
12	User_define_GEN2_REPLAY_TIMER	RW	0b: disable user defined replay timer for GEN2 1b: enable user defined replay timer for GEN2	Yes	0b
21:13	retry buffer threshold for 512	RW	Used to set retry buffer threshold for 512 payload.	Yes	1E0h
23:22	External dlp_tx_block_ctrl	RW	Internal used only.	Yes	11b
31:24	Internal dlp_tx_block_ctrl	RW	Internal used only	Yes	FBh

9.4.137 DLL CSR 5 REGISTER – OFFSET 434h

BIT	FUNCTION	TYPE	DESCRIPTION	EEPROM/ I2C-SMBUS	DEFAULT
11:0	GEN3_REPLAY_TIMER_CTRL	RW	User defined replay timeout value for GEN3.	Yes	000h
12	User_define_GEN3_REPLAY_TIMER	RW	0b: disable user defined replay timer for GEN3 1b: enable user defined replay timer for GEN3	Yes	0b
13	reserved	RO	Not support	No	0b
15:14	Loopback synchronous signal	RO	Internal used only.	No	0h
27:16	Loopback error count	RW1C	Only bit 16 write one to clear count.	No	0h
29:28	DLP TX control	RW	Internal used only.	Yes	01b
30	Loopback insert error	RW	User insert error to loopback.	Yes	0b
31	Loopback packet start	RW	Start loopback packet.	Yes	0b

9.4.138 DLL CSR 6 REGISTER – OFFSET 438h

BIT	FUNCTION	TYPE	DESCRIPTION	EEPROM/ I2C-SMBUS	DEFAULT
6:0	INI_FLOW_CTRL	RW	bit[2:0]: The value of firing initial flow control after getting flow control from frond end bit[3]: user enable bit[4]: enable to make initial flow control 1 transfer to initial flow control 2 early by getting any TLP or initial flow control 2 bit[5]: enable to make initial flow control 2 transfer to initial done by getting any TLP bit[6]: enable to make initial flow control to initial done by getting any good TLP or update flow control	Yes	70h
7	INI_FLOW2_EN	RW	Don't need initial flow control 2.	Yes	0
8	Dis_replaytimer_rx	RW	Used to disable Replay timer enable in RX L0s.	Yes	1
9	Dis_replaytimer_tx	RW	Used to disable Replay timer enable in TX L0s.	Yes	0

BIT	FUNCTION	TYPE	DESCRIPTION	EEPROM/ I2C-SMBUS	DEFAULT
10	En_duplicate_seq_nak	RW	Used to enable duplicate sequence number for NAK.	Yes	0
11	En_bypass_flowctrl	RW	Used to bypass initial flow control 1 to TL.	Yes	1
12	Rx_polarity_force_en	RW	Used to enable RX polarity force.	Yes	0
15:13	Reserved	RsvdP	Not support.	No	000b
31:16	Rx_polarity_value	RW	Used to set rx polarity value for 16 lanes.	Yes	0000h

9.4.139 DLL CSR 7 REGISTER – OFFSET 43Ch

BIT	FUNCTION	TYPE	DESCRIPTION	EEPROM/ I2C-SMBUS	DEFAULT
8:0	DLL_DEBUG_SEL	RW	Data link layer debug select.	Yes	0_0b
9	DLL Error Enable	RW	Used to enable or disable DLL Error report to AER. 0b: disable 1b: enable	Yes	1
10	TLP Error Enable	RW	Used to enable or disable TLP Error report to AER.	Yes	1
11	DLL Protocol Error Enable_Disable	RW	Used to enable or disable DLL Protocol Error report to AER. 0b: disable for P1~P7, enable for P0 and P4 1b: enable for P1~P7, disable for P0 and P4	Yes	1
12	Receive Error Enable	RW	Used to enable or disable Receive Error to AER. 0b: disable 1b: enable	Yes	1
16:13	MAC ERR extend control	RW	Internal used only.	Yes	7h
18:17	EIOS amount control	RW	Internal used only.	Yes	00b
24:19	DLL rx control	RW	Internal used only.	Yes	7h
29:25	Reserved	RsvdP	Not support.	No	0_0h
31:30	Loopback mode status	RO	Indicate loopback mode status.	No	00b

9.4.140 DLL CSR 8 REGISTER – OFFSET 440h

BIT	FUNCTION	TYPE	DESCRIPTION	EEPROM/ I2C-SMBUS	DEFAULT
12:0	ERR_CTRL_500M	RW	bit[0]: EIEOS error status enable bit[1]: SKIP on data stream error status enable bit[2]: NFTS error status enable bit[3]: SKIP framing error status enable bit[4]: GEN3 logical idle error status enable bit[5]: EDS token to get FTS error status enable bit[6]: GEN3 FCRC error status enable bit[7]: GEN3 EDB token error status enable bit[8]: GEN3 TLP framing error status enable bit[9]: TLP Framing check enable bit[10]: GEN1/2 TLP framing error status error enable bit[11]: GEN1/2 PAD framing error status enable bit[12]: GEN1/2 SDP framing error status enable	Yes	0000h
13	GEN1/2_framing_err_en	RW	GEN1/2 framing error enable.	Yes	0
14	Recovery_enable_for_err_detect	RW	Recovery enable for error detect.	Yes	1
15	Recovery_for_replay_rollover	RW	Replay rollover to recovery enable.	Yes	1
16	GEN3_sync_header_err_detect	RW	GEN3 synchronous header error detect.	Yes	1
17	PHY_err_detect_en	RW	PHY status error detect enable.	Yes	1
18	GEN3_skip_back2_back_err_detect	RW	GEN3 SKIP back 2 back error detect.	Yes	0

BIT	FUNCTION	TYPE	DESCRIPTION	EEPROM/ I2C-SMBUS	DEFAULT
19	Elastic_buf_overnun_detect	RW	Elastic buffer overrun detect.	Yes	0
20	Elastic_buf_underrun_detect	RW	Elastic buffer underrun detect.	Yes	0
21	GEN3_decode_error_detect	RW	GEN3 decode error detect ,	Yes	0
22	Recovery_lane_detect_error_en	RW	Enable Lane detect error to recovery.	Yes	1
23	Recovery_ordered_set_error_en	RW	Enable ordered set error to recovery.	Yes	0
31:24	Recovery_rx_error_amount	RW	RX status error amount to recovery.	Yes	03h

9.4.141 DLL CSR 9 REGISTER – OFFSET 444h

BIT	FUNCTION	TYPE	DESCRIPTION	EEPROM/ I2C-SMBUS	DEFAULT
15:0	GEN3_FC_LIFE_CTRL_POST	RW	bit[15]: user define update flow control life cycle enable for post bit[14]: reserved bit[13:2]: user define update flow control life cycle value for post bit[1:0]: reserved	Yes	0000h
31:16	GEN2_FC_LIFE_CTRL_POST	RW	bit[15]: user define update flow control life cycle enable for post bit[14]: reserved bit[13:2]: user define update flow control life cycle value for post bit[1:0]: reserved	Yes	0000h

9.4.142 DLL CSR 10 REGISTER – OFFSET 448h

BIT	FUNCTION	TYPE	DESCRIPTION	EEPROM/ I2C-SMBUS	DEFAULT
15:0	GEN3_FC_LIFE_CTRL_NP	RW	bit[15]: user define update flow control life cycle enable for non-post bit[14]: reserved bit[13:2]: user define update flow control life cycle value for non-post bit[1:0]: reserved	Yes	0000h
31:16	GEN2_FC_LIFE_CTRL_NP	RW	bit[15]: user define update flow control life cycle enable for non-post bit[14]: reserved bit[13:2]: user define update flow control life cycle value for non-post bit[1:0]: reserved	Yes	0000h

9.4.143 DLL CSR 11 REGISTER – OFFSET 44Ch

BIT	FUNCTION	TYPE	DESCRIPTION	EEPROM/ I2C-SMBUS	DEFAULT
15:0	GEN3_FC_LIFE_CTRL_CPL	RW	bit[15]: user define update flow control life cycle enable for completion bit[14]: reserved bit[13:2]: user define update flow control life cycle value for completion bit[1:0]: reserved	Yes	0000h
31:16	GEN2_FC_LIFE_CTRL_CPL	RW	bit[15]: user define update flow control life cycle enable for completion bit[14]: reserved bit[13:2]: user define update flow control life cycle value for completion bit[1:0]: reserved	Yes	0000h

9.4.144 DLL CSR 12 REGISTER – OFFSET 450h

BIT	FUNCTION	TYPE	DESCRIPTION	EEPROM/ I2C-SMBUS	DEFAULT
0	SKIP_LFSR_CTRL_500M	RW	GEN3 LFSR value correct enable by SKIP.	Yes	1
1	tlp_payload_ignore_detect	RW	TLP payload ignore detect.	Yes	0
2	x16_tlp_back2back_cal_en	RW	For x16 TLP back 2 back calculate enable for receiver.	Yes	0
3	Force_disable_tlp_send	RW	Force to disable TLP sent when TLP empty.	Yes	1
6:4	GEN3_de-skew_reset_count	RW	GEN3 de-skew reset count.	Yes	111b
7	GEN3_rx_idle_en	RW	GEN3 Rx electric idle enable for data valid or not	Yes	1
10:8	GEN1/2_de-skew_reset_count	RW	GEN1/2 de-skew reset count.	Yes	111b
27:11	Reserved	RsvdP	Not support.	No	0050h
31:28	x16_tlp_back2back_count	RO	x16 TLP back 2 back count. Use bit 2 to clear.	Yes	0h

9.4.145 DLL CSR 13 REGISTER – OFFSET 454h

BIT	FUNCTION	TYPE	DESCRIPTION	EEPROM/ I2C-SMBUS	DEFAULT
0	NULLIFIED_FLAG_500M	RO	Nullified TLP detect.	No	0
1	ENDING_FLAG_500M	RO	Ending of TLP is not consistent to total length.	No	0
2	SEQ_NUM_ERR_DET	RO	Sequel number wrong.	No	0
3	BUFFER_FULL_DET	RO	Retry buffer is full.	No	0
4	ECC_Correct	RO	ECC correctable detect error.	No	0
5	ECC_Uncorrect	RO	ECC uncorrectable detect error.	No	0
6	REPLAY_DET	RO	Replay timeout detect.	No	0
7	CRC16_DET	RO	SDP of data link layer of CRC error detect.	No	0
8	CRC32_DET	RO	TLP of data link layer of CRC error detect.	No	0
9	CRC32_NULL_DET	RO	TLP of data link layer of nullified CRC detect.	No	0
11:10	Reserved	RsvdP	Not support.	No	00b
14:12	RX PM ACK Number	RW	Used to set rx PM ACK number. The range is from 0 to 6.	Yes	011b
15	Reserved	RsvdP	Not support.	No	1
18:16	TX PM ACK Number	RW	Used to send tx PM ACK number. The range is from 0 to 6.	Yes	000b
31:19	Reserved	RsvdP	Not support. If the link is x16, the default value is 11E3h. Otherwise, the default value is 01E3h	No	03E3h

9.4.146 DLL CSR 14 REGISTER – OFFSET 458h

BIT	FUNCTION	TYPE	DESCRIPTION	EEPROM/ I2C-SMBUS	DEFAULT
11:0	RX_NAK_SEQ_NUM	RO	NAK sequence number record for receiver.	Yes	000h
14:12	Reserved	RsvdP	Not support.	No	000b
15	RX_NAK_FLAG	RO	NAK flag asserted of receiver.	No	0
27:16	TX_NAK_SEQ_NUM	RO	NAK sequence number record for transmitter.	Yes	000h
30:28	Reserved	RsvdP	Not support.	No	000b
31	TX_NAK_FLAG	RO	NAK flag asserted of transmitter.	No	0

9.4.147 DLL CSR 15 REGISTER – OFFSET 45Ch

BIT	FUNCTION	TYPE	DESCRIPTION	EEPROM/ I2C-SMBUS	DEFAULT
0	Nullified Enable	RW	When set, enable to generated nullified packet.	Yes	1
1	Data Link Layer Reset	RW1C	Reset of data link layer.	Yes	0
2	TLP Ending Choice	RW	TLP of Ending choice by length or write to buffer.	Yes	0
3	Block List Full Select	RW	TLP Block list full select enable.	Yes	0
7:4	RxReceive Threshold Value	RW	Rx receive threshold value.	Yes	8h
8	x16 Low Latency Enable	RW	x16 low latency enable when common mode	Yes	0
9	x16 Synchronous Mode	RW	x16 Tx synchronous enable when common mode.	Yes	0
12:10	GEN1_FTS_skew_Range_value	RW	GEN1 FTS skew range value.	Yes	011b
15:13	GEN2_FTS_skew_Range_value	RW	GEN2 FTS skew range value.	Yes	001b
19:16	GEN1_de-skew_range_value	RW	GEN1 de-skew range value.	Yes	Ch
23:20	GEN2_de-skew_range_value	RW	GEN2 de-skew range value.	Yes	Ch
27:24	GEN3_de-skew_Rnage_value	RW	GEN3 de-skew range value.	Yes	Ch
28	L0 State and Non valid for Surprise Disconnect	RW	Internal used only.	Yes	0
29	Port Bifurcating Enable	RW	When set, enable port bifurcating function.	Yes	0
30	Skip_mask_select_en	RW	SKIP mask select enable for DLP.	Yes	0
31	Reserved	RsvdP	Not support.	No	0

9.4.148 DLL CSR 16 REGISTER – OFFSET 460h

BIT	FUNCTION	TYPE	DESCRIPTION	EEPROM/ I2C-SMBUS	DEFAULT
31:0	DLL_TX_DEBUG_i	RO	Internal used only.	No	0000_0070h

9.4.149 DLL CSR 17 REGISTER – OFFSET 464h

BIT	FUNCTION	TYPE	DESCRIPTION	EEPROM/ I2C-SMBUS	DEFAULT
31:0	DLL_RX_DEBUG_i	RO	Internal used only.	No	0000_0000h

9.4.150 DLL CSR 18 REGISTER – OFFSET 468h

BIT	FUNCTION	TYPE	DESCRIPTION	EEPROM/ I2C-SMBUS	DEFAULT
31:0	MAC_TX_DEBUG_i	RO	Internal used only.	No	0098_0029h

9.4.151 DLL CSR 19 REGISTER – OFFSET 46Ch

BIT	FUNCTION	TYPE	DESCRIPTION	EEPROM/ I2C-SMBUS	DEFAULT
31:0	MAC_RX_DEBUG_i	RO	Internal used only.	No	0000_0000h

9.4.152 LA DEBUG REGISTER – OFFSET 470h

BIT	FUNCTION	TYPE	DESCRIPTION	EEPROM/ I2C-SMBUS	DEFAULT
3:0	initial flow control 2	RW	Internal used only.	Yes	1011b
4	flow control life cycle synchronous	RW	Internal used only.	Yes	0
5	initial flow control 2 expire enable	RW	Internal used only.	Yes	0
6	GEN3 auto change lane width	RW	Internal used only.	Yes	1
7	de-skew delay time disable	RW	Internal used only.	Yes	1
31:8	misc	RW	Internal used only.	Yes	7000_00h

9.4.153 TL CSR 0 REGISTER – OFFSET 4C0h

BIT	FUNCTION	TYPE	DESCRIPTION	EEPROM/ I2C-SMBUS	DEFAULT
0	decode_vga	RW	0b: disable VGA decode 1b: enable VGA decode	Yes	1
1	msi_cap_dis	RO	0b: enable MSI capability 1b: disable MSI capability	Yes	0
2	pwr_cap_dis	RO	0b: enable power capability 1b: disable power capability	Yes	0
3	mf_credit_update_dis	RO	Internal used only.	Yes	0
4	mc_cap_dis	RO	Internal used only.	Yes	0
5	mem_sharing_dis	RO	0b: enable memory sharing 1b: disable memory sharing It is set by Port 0 only. When set, it will affect the entire switch.	Yes	0
7:6	Reserved	RsvdP	Not support.	No	00b
8	p_inta_slot	RW	Internal used only.	Yes	0
9	p_inta_gpio	RW	Internal used only.	Yes	0
10	p_inta_ntl	RW	Internal used only.	Yes	0
11	Reserved	RsvdP	Not support.	No	0
13:12	initial credit threshold	RO	Internal used only.	Yes	00b
31:14	Reserved	RsvdP	Not support.	No	0-0h

9.4.154 TL CSR 1 REGISTER – OFFSET 4C4h

BIT	FUNCTION	TYPE	DESCRIPTION	EEPROM/ I2C-SMBUS	DEFAULT
0	store_en	RW	When set, a store-forward mode is used. Otherwise, the chip is working under cut-through mode. It is valid for upstream port only.	Yes	0
3:1	cut-through threshold	RW	Cut-through Threshold. 00b: the threshold is set at the middle of forwarding packet 01b: the threshold is set ahead 1-cycle of middle point 10b: the threshold is set ahead 2-cycle of middle point 11b: the threshold is set ahead 3-cycle of middle point It is valid for upstream port only.	Yes	100b
4	port_arb_mode	RW	When set, the round-robin arbitration will stay in the arbitrated port even if the credit is not enough but request is pending. When clear, the round-robin arbitration will always go to the requesting port, which the outgoing credit is enough for the packet queued in the port. It is valid for upstream port only	Yes	0

BIT	FUNCTION	TYPE	DESCRIPTION	EEPROM/ I2C-SMBUS	DEFAULT
5	port_order	RW	When set, there is forced ordering rule on packets for different egress port. It is valid for upstream port only.	Yes	0
6	cpl_order	RW	When set, there is forced ordering rule between completion packet with different tag. It is valid for upstream port only.	Yes	0
7	np_store_en	RW	When set, for Non-post TLP store-forward mode is used. Otherwise, Non-post TLP is working under cut-through mode. It is valid for upstream port only.	Yes	0
8	Reserved	RW	Internal used only.	No	0
9	datasel_rw_en	RO	When set, PM data register's DATA SEL is R/W.	Yes	0
10	Reserved	RW	Internal used only.	No	0
11	4k_boundary_check_en	RW	0b: disable 1b: enable 4KB boundary check	Yes	0
12	Reserved	RsvdP	Not support.	No	0
13	order_rule5_en	RW	When set, Post packet cannot pass Non-post Packet.	Yes	0
14	ordering_forzen_p_dis	RW	For Post packets.	Yes	0
15	ordering_forzen_np_dis	RW	For Non-Post packets.	Yes	1
16	RX Poison TLP mode	RW	Internal used only.	Yes	0
17	RX ECRC TLP mode	RW	Internal used only.	Yes	0
18	RX MC overlay TLP ECRC mode	RW	Internal used only.	Yes	0
31:19	Reserved	RsvdP	Not support.	No	0-0h

9.4.155 TL CSR 2 REGISTER – OFFSET 4C8h

BIT	FUNCTION	TYPE	DESCRIPTION	EEPROM/ I2C-SMBUS	DEFAULT
0	dma_cap	RO	When Set, DMA is enabled.	Yes	0
1	non_trans_	RO	When Set, non transparent mode is enabled.	Yes	1
2	Power_saving_en	RO	When set power saving mode is enabled. It is set by Port 0 only. When set, it will affect the entire switch.	Yes	1
3	Reserved	RW	Not support.	No	0
4	overlay_tlp_fc_update_mode	RW	When set, overlay tlp fc update mode is set.	Yes	1
5	egress_tlp_request_mode	RW	When set, egress tlp request mode is set. It is set by Port 0 only. When set, it will affect the entire switch.	Yes	0
6	emulate RD TRACKING TX_READY	RW	Internal used only.	Yes	0
7	broadcast CFGWRI mode	RW	Internal used only.	Yes	0
31:8	Reserved	RsvdP	Not support.	No	0-0b

9.4.156 TL CSR 3 REGISTER – OFFSET 4CCh (Port 0 Only)

BIT	FUNCTION	TYPE	DESCRIPTION	EEPROM/ I2C-SMBUS	DEFAULT
3:0	vp port ring_csr	RO	Internal used only.	Yes	1010b
4	vp port cut through ctrl	RO	Internal used only.	Yes	0
31:5	Reserved	RsvdP	Not support.	No	0_0h

9.4.157 TL CSR 4 REGISTER – OFFSET 4D0h

BIT	FUNCTION	TYPE	DESCRIPTION	EEPROM/ I2C-SMBUS	DEFAULT
23:0	Reserved	RsvdP	Not support.	No	00_0000h
31:24	specific TL debug mode_sel	RW	Internal used only.	Yes	00h

9.4.158 DEVICE CONFIGURATION 0 REGISTER – OFFSET 504h (Port 0 Only)

BIT	FUNCTION	TYPE	DESCRIPTION	EEPROM/ I2C-SMBUS	DEFAULT
2:0	Up Port Selection	RO	Used to do up port selection. It is valid for transparent mode only.	Yes	000b
5:3	Reserved	RsvdP	Not support.	No	000b
6	Chip CD Mode	RO	Used to enable CD mode for the whole chip. 1: Enable Chip CD mode (i.e. switch operates in cross-domain mode) 0: Disable Chip CD mode (i.e. switch operates in transparent mode)	Yes	1
7	Smbus Enable	RO	Used to set SMBUS_EN_L strap pin. 0b: I2C 1b: SMBUS	Yes	Set by SMBUS_EN_L
10:8	I2C/Smbus Address	RO	Used to set I2C_ADDRESS[2:0] strap pins.	Yes	Set by I2C_ADDRESS[2:0]
11	Debug_Mode	RO	0b: disable debug mode 1b: enable debug mode	Yes	0
31:12	Reserved	RsvdP	Not support.	No	0000_0h

9.4.159 DEVICE CONFIGURATION 1 REGISTER – OFFSET 508h (Port 0 Only)

BIT	FUNCTION	TYPE	DESCRIPTION	EEPROM/ I2C-SMBUS	DEFAULT
1:0	Reserved	RsvdP	Not support.	No	00b
4:2	PORTCFG	RO	Used to set PORTCFG[2:0] strap pins.	Yes	Set by PORTCFG[2:0]
6:5	Chip Mode	RO	Used to set CHIPMODE[1:0] strap pins.	Yes	Set by CHIPMODE[1:0]
7	Fast Mode	RO	0b: disable fast mode 1b: enable fast mode, for internal used only	Yes	0
8	Ckmode	RO	Used to set CKMODE strap pin.	Yes	Set by CKMODE
31:9	Reserved	RsvdP	Not support.	No	0-0b

9.4.160 DEVICE CONFIGURATION 2 REGISTER – OFFSET 50Ch (Port 0 Only)

BIT	FUNCTION	TYPE	DESCRIPTION	EEPROM/ I2C-SMBUS	DEFAULT
0	Reserved	RsvdP	Not support.	No	0
1	HotPlug_Enable	RO	Used to enable/disable hot plug function. 0b: disable 1b: enable	Yes	Set by HOT_PLUG_EN_L
2	Surprise_Hot_Plug_Disable	RO	Used to select surprise or managed hot plug function. 0b: surprise hot plug 1b: managed hot plug	Yes	Set by SURPRISE_HP

BIT	FUNCTION	TYPE	DESCRIPTION	EEPROM/ I2C-SMBUS	DEFAULT
3	IOE_40Bit_Disable	RO	Used to set IOE is 16 bit or 40 bit. 0b: 40 bit IOE 1b: 16 bit IOE	Yes	0
4	Pm_L1_1_Enable	RO	Used to enable/disable PM L1.1 function. 0b: disable 1b: enable	Yes	Set by PM_L1_1_EN_L
7:5	Rsvrd	RsvdP	Not support.	No	001b
8	CLKBUF_PD	RO	Used to power down or off internal clock buffer. 0b: power on 1b: power down	Yes	Set by CLKBUF_PD_L
14:9	Reserved	RsvdP	Not support.	No	000000b
15	P4_RID_Auto_Set	RO	Used to set RID table being automatically built and maintained by the switch hardware in CDLEP/CDBR Port 4.	Yes	1
17:16	Switch CD Mode	RO	Used to configure CDEP Port for this switch. 0xb: no CDEP ports configured in this switch 10b: not support 11b: one CDVEP port and one CDLEP port The setting in Switch CD Mode can be ignored if Chip CD Mode is disabled.	Yes	00b
19:18	DMA Mode	RO	Used to configure DMA Mode for this switch. 0xb: DMA functions are disabled in this switch 10b: DMA function s enabled under its own main or local hosts Switch CD Mode = 0x: DMA functions are at P0 only Switch CD Mode = 11: DMA functions are at P0 and P4 respectively 11b: DMA function only enabled under the main host domain and DMA functions are enabled at P0 only	Yes	00b
20	CLKBUF_CTL_EN	RO	Used to enable internal clock buffer outputs control.	Yes	0
21	Reserved	RsvdP	Not support.	No	0
22	Reserved	RsvdP	Not support.	No	0
23	Reserved	RsvdP	Not support.	No	0
31:24	CLKBUF_Output_En	RO	Used to enable/disable internal clock buffer outputs REFCLKOP/N[7:0] 0b: disable 1b: enable These bits are valid when bit[20]=1.	Yes	FFh

9.4.161 DEVICE CLOCK EXTERNAL CONTROL REGISTER – OFFSET 510h (Port 0 Only)

BIT	FUNCTION	TYPE	DESCRIPTION	EEPROM/ I2C-SMBUS	DEFAULT
15:0	EE_Ext_Pclk_Req	RO	Device Ext_Pclk_Req Control from EEPROM.	Yes/No	0000h
19:16	EE_Mplla_Force_En	RO	Device Mplla_Force_En able Control from EEPROM.	Yes/No	0h
23:20	EE_Ref_Use_Pad	RO	Device Ref_Use_Pad_Enable Control from EEPROM.	Yes/No	0h
27:24	EE_Ref_Repeat_Clk_En	RO	Device Ref_Repeat_Clk_Enable Control from EEPROM.	Yes/No	0h
28	EE_Phy_Control_En	RO	Device Phy Clock External Control Enable from EEPROM.	Yes/No	0
29	Valid for bit[19:16]	RO	1b: bit[19:16] are valid.	Yes/No	0
30	Valid for bit[23:20]	RO	1b: bit[23:20] are valid.	Yes/No	0
31	Reserved	RsvdP	Not support.	No	0

9.4.162 DEVICE SRIS EXTERNAL CONTROL REGISTER – OFFSET 514h (Port 0 Only)

BIT	FUNCTION	TYPE	DESCRIPTION	EEPROM/ I2C-SMBUS	DEFAULT
0	lane 0_Sris_Mode	RO	Lane 0_Sris_ModeExternal Control from EEPROM.	Yes/No	0
1	lane 1_Sris_Mode	RO	Lane 1_Sris_ModeExternal Control from EEPROM.	Yes/No	0
2	lane 2_Sris_Mode	RO	Lane 2_Sris_ModeExternal Control from EEPROM.	Yes/No	0
3	lane 3_Sris_Mode	RO	Lane 3_Sris_ModeExternal Control from EEPROM.	Yes/No	0
4	lane 4_Sris_Mode	RO	Lane 4_Sris_ModeExternal Control from EEPROM.	Yes/No	0
5	lane 5_Sris_Mode	RO	Lane 5_Sris_ModeExternal Control from EEPROM.	Yes/No	0
6	lane 6_Sris_Mode	RO	Lane 6_Sris_ModeExternal Control from EEPROM.	Yes/No	0
7	lane 7_Sris_Mode	RO	Lane 7_Sris_ModeExternal Control from EEPROM.	Yes/No	0
8	lane 8_Sris_Mode	RO	Lane 8_Sris_ModeExternal Control from EEPROM.	Yes/No	0
9	lane 9_Sris_Mode	RO	Lane 9_Sris_ModeExternal Control from EEPROM.	Yes/No	0
10	lane 10_Sris_Mode	RO	Lane 10_Sris_ModeExternal Control from EEPROM.	Yes/No	0
11	lane 11_Sris_Mode	RO	Lane 11_Sris_ModeExternal Control from EEPROM.	Yes/No	0
12	lane 12_Sris_Mode	RO	Lane 12_Sris_ModeExternal Control from EEPROM.	Yes/No	0
13	lane 13_Sris_Mode	RO	Lane 13_Sris_ModeExternal Control from EEPROM.	Yes/No	0
14	lane 14_Sris_Mode	RO	Lane 14_Sris_ModeExternal Control from EEPROM.	Yes/No	0
15	lane 15_Sris_Mode	RO	Lane 15_Sris_ModeExternal Control from EEPROM.	Yes/No	0
30:16	Reserved	RsvdP	Not support.	No	0-0b
31	Sris External Control En	RO	Device Sris External Control Enble.	Yes/No	0

9.4.163 DEVICE COMM REFCLK MODE EXTERNAL CONTROL REGISTER – OFFSET 518h (Port 0 Only)

BIT	FUNCTION	TYPE	DESCRIPTION	EEPROM/ I2C-SMBUS	DEFAULT
0	lane 0_Cmn_Refclk_Mode	RO	Lane 0_Cmm Refclk ModeExternal Control from EEPROM.	Yes/No	0
1	lane 1_Cmn_Refclk_Mode	RO	Lane 1_Cmm Refclk ModeExternal Control from EEPROM.	Yes/No	0
2	lane 2_Cmn_Refclk_Mode	RO	Lane 2_Cmm Refclk ModeExternal Control from EEPROM.	Yes/No	0
3	lane 3_Cmn_Refclk_Mode	RO	Lane 3_Cmm Refclk ModeExternal Control from EEPROM.	Yes/No	0
4	lane 4_Cmn_Refclk_Mode	RO	Lane 4_Cmm Refclk ModeExternal Control from EEPROM.	Yes/No	0
5	lane 5_Cmn_Refclk_Mode	RO	Lane 5_Cmm Refclk ModeExternal Control from EEPROM.	Yes/No	0
6	lane 6_Cmn_Refclk_Mode	RO	Lane 6_Cmm Refclk ModeExternal Control from EEPROM.	Yes/No	0
7	lane 7_Cmn_Refclk_Mode	RO	Lane 7_Cmm Refclk ModeExternal Control from EEPROM.	Yes/No	0
8	lane 8_Cmn_Refclk_Mode	RO	Lane 8_Cmm Refclk ModeExternal Control from EEPROM.	Yes/No	0
9	lane 9_Cmn_Refclk_Mode	RO	Lane 9_Cmm Refclk ModeExternal Control from EEPROM.	Yes/No	0
10	lane 10_Cmn_Refclk_Mode	RO	Lane 10_Cmm Refclk ModeExternal Control from EEPROM.	Yes/No	0
11	lane 11_Cmn_Refclk_Mode	RO	Lane 11_Cmm Refclk ModeExternal Control from EEPROM.	Yes/No	0
12	lane 12_Cmn_Refclk_Mode	RO	Lane 12_Cmm Refclk ModeExternal Control from EEPROM.	Yes/No	0
13	lane 13_Cmn_Refclk_Mode	RO	Lane 13_Cmm Refclk ModeExternal Control from EEPROM.	Yes/No	0
14	lane 14_Cmn_Refclk_Mode	RO	Lane 14_Cmm Refclk ModeExternal Control from EEPROM.	Yes/No	0
15	lane 15_Cmn_Refclk_Mode	RO	Lane 15_Cmm Refclk ModeExternal Control from EEPROM.	Yes/No	0
30:16	Rserved	RsvdP	Not support.	No	0-0b
31	Cmn_Refclk_Mode External Control En	RO	Device Cmm Refclk Mode External Control Enble.	Yes/No	0

9.4.164 MBIST CFG CONTROL REGISTER – OFFSET 51Ch (Port 0 Only)

BIT	FUNCTION	TYPE	DESCRIPTION	EEPROM/ I2C-SMBUS	DEFAULT
0	Cfg_Mbist_En	RW	Used to set Mbist Enable from CFG Control.	Yes	0000h
1	Cfg_Mbist_mode	RW	Used to set Mbist En from Pin or CFG.	Yes	0h
31:2	Cfg_Mbist_done	RO	Used to indicate Mbist test Done.	No	0-0h

9.4.165 MBIST CFG STATUS REGISTER – OFFSET 520h (Port 0 Only)

BIT	FUNCTION	TYPE	DESCRIPTION	EEPROM/ I2C-SMBUS	DEFAULT
29:0	Cfg_Mbist_Error	RO	Used to indicate Mbist error. It can be read from I2C-SMBUS only.	No	0-0h
31:30	Reserved	RsvdP	Not support.	No	00b

9.4.166 NOC BIST CONTROL REGISTER – OFFSET 524h (Port 0 Only)

BIT	FUNCTION	TYPE	DESCRIPTION	EEPROM/ I2C-SMBUS	DEFAULT
0	Noc Bist Enable	RO	Used to enable Noc Bist Test.	Yes/No	0
1	Noc_Bist_Enable_sel	RO	Used to select the NOC Bist Enable Source. 1b: Noc Bist Control Register bit[0] 0b: Jtag	Yes/No	0
23:2	Reserved	RsvdP	Not support.	No	0-0b
31:24	Noc Bist Status	RO	Noc Bist Status. It can be read from I2C-SMBUS only.	No	00h

9.4.167 EXTERNAL LOOPBACK PRBS CONTROL REGISTER – OFFSET 528h (Port 0 Only)

BIT	FUNCTION	TYPE	DESCRIPTION	EEPROM/ I2C-SMBUS	DEFAULT
1:0	Lane 3-0 PRBS Rate	RW	Choose Lane 3-0 PRBS Rate. 00b: GEN1 01b: GEN2 10b: GEN3 11b: Reserved	Yes	00b
3:2	Lane 7-4 PRBS Rate	RW	Choose Lane 7-4 PRBS Rate. 00b: GEN1 01b: GEN2 10b: GEN3 11b: Reserved	Yes	00b
5:4	Lane 11-8 PRBS Rate	RW	Choose Lane 11-8 PRBS Rate. 00b: GEN1 01b: GEN2 10b: GEN3 11b: Reserved	Yes	00b
7:6	Lane 15-12 PRBS Rate	RW	Choose Lane 15-12 PRBS Rate. 00b: GEN1 01b: GEN2 10b: GEN3 11b: Reserved	Yes	00b

BIT	FUNCTION	TYPE	DESCRIPTION	EEPROM/ I2C-SMBUS	DEFAULT
8	Lane 3-0 PRBS Rate Enable	RW	When enabled, Lane 3-0 is set to PRBS rate as indicated in bit[1:0] to run loopback test. Please note an external test fixture must be provided to loopback TX to RX. Also, please follow PRBS Appnote to set TXEQ PRESET value at GEN3 speed through CR interface.	Yes	0
9	Lane 7-4 PRBS Rate Enable	RW	When enabled, Lane 7-4 is set to PRBS rate as indicated in bit[3:2] to run loopback test. Please note an external test fixture must be provided to loopback TX to RX. Also, please follow PRBS Appnote to set TXEQ PRESET value at GEN3 speed through CR interface.	Yes	0
10	Lane 11-8 PRBS Rate Enable	RW	When enabled, Lane 11-8 is set to PRBS rate as indicated in bit[5:4] to run loopback test. Please note an external test fixture must be provided to loopback TX to RX. Also, please follow PRBS Appnote to set TXEQ PRESET value at GEN3 speed through CR interface.	Yes	0
11	Lane 15-12 PRBS Rate Enable	RW	When enabled, Lane 15-12 is set to PRBS rate as indicated in bit[7:6] to run loopback test. Please note an external test fixture must be provided to loopback TX to RX. Also, please follow PRBS Appnote to set TXEQ PRESET value at GEN3 speed through CR interface.	Yes	0
31:12	Reserved	RsvdP	Not support.	No	0000_0h

9.4.168 PHY SRAM PROGRAM 0 REGISTER – OFFSET 52Ch (Port 0 Only)

BIT	FUNCTION	TYPE	DESCRIPTION	EEPROM/ I2C-SMBUS	DEFAULT
15:0	PHY SRAM DATA	RO	PHY SRAM DATA.	Yes/No	0000h
31:16	PHY SRAM OFFSET	RO	PHY SRAM OFFSET.	Yes/No	0000h

9.4.169 PHY SRAM PROGRAM 1 REGISTER – OFFSET 530h (Port 0 Only)

BIT	FUNCTION	TYPE	DESCRIPTION	EEPROM/ I2C-SMBUS	DEFAULT
0	PHY SRAM Program Enable	RO	Start PHY SRAM Program.	Yes/No	0
1	PHY SRAM Program Done	RO	Finish PHY SRAM Program.	Yes/No	0
31:2	Reserved	RsvdP	Not support.	No	0-0b

9.4.170 FAILOVER CONTROL REGISTER – OFFSET 534h (Port 0 Only)

BIT	FUNCTION	TYPE	DESCRIPTION	EEPROM/ I2C-SMBUS	DEFAULT
0	Reserved	RsvdP	Not support.		0
1	dis_dn_hotreset	RW	Used to disable up link down, fire down port hot-reset event. 0b: enable 1b: disable	Yes	0
2	En_up_keep_enum	RW	Used to enable up link down, keep up port enum data. 0b: disable 1b: enable	Yes	0
31:3	Reserved	ResvP	Not support.	No	0-0b

9.4.171 THERMAL SENSOR INT MASK AND STATUS REGISTER – OFFSET 538h (Port 0 Only)

BIT	FUNCTION	TYPE	DESCRIPTION	EEPROM/ I2C-SMBUS	DEFAULT
2:0	thermal sensor 2~0 status	RW1C	Thermal sensor 2~0 status.	Yes	000b
15:3	Reserved	RsvdP	Not support.	No	0-0b
18:16	thermal sensor 2~0 interrupt mask	RW	Thermal sensor 2~0 interrupt mask.	Yes	111b
31:19	Reserved	RsvdP	Not support.	No	0-0b

9.4.172 THERMAL SENSOR CONTROL REGISTER – OFFSET 53Ch (Port 0 Only)

BIT	FUNCTION	TYPE	DESCRIPTION	EEPROM/ I2C-SMBUS	DEFAULT
0	Thermal Sensor 0 Status	RO	Used to indicate the temp over the Threshold	No	0b
1	Thermal Sensor 1 Status	RO	Used to indicate the temp over the Threshold	No	0b
2	Thermal Sensor 2 Status	RO	Used to indicate the temp over the Threshold	No	0b
23:3	Reserved	RsvdP	Not support.	No	0_0h
25:24	Thermal Sensor 0 Threshold	RW	Used to set the threshold of chip temperature. 00b:110 01b:120 10b: 130 11b: 140	Yes	0
27:26	Thermal Sensor 1 Threshold	RW	Used to set the threshold of chip temperature. 00b:110 01b:120 10b: 130 11b: 140	Yes	0
29:28	Thermal Sensor 2 Threshold	RW	Used to set the threshold of chip temperature. 00b:110 01b:120 10b: 130 11b: 140	Yes	0
30	Reserved	RsvdP	Not support.	No	0
31	Auto Test Temp.	RW	Used to set Thermal Sensor burst test Enable	Yes	0

9.4.173 DEVICE ELASTIC BUFFER EMPTY MODE EXTERNAL CONTROL REGISTER – OFFSET 540h (Port 0 Only)

BIT	FUNCTION	TYPE	DESCRIPTION	EEPROM/ I2C-SMBUS	DEFAULT
0	lane 0_Eb_Empty_Mode	RO	Lane 0_Eb_Empty_Mode External Control from EEPROM.	Yes/No	0
1	lane 1_Eb_Empty_Mode	RO	Lane 1_Eb_Empty_Mode External Control from EEPROM.	Yes/No	0
2	lane 2_Eb_Empty_Mode	RO	Lane 2_Eb_Empty_Mode External Control from EEPROM.	Yes/No	0
3	lane 3_Eb_Empty_Mode	RO	Lane 3_Eb_Empty_Mode External Control from EEPROM.	Yes/No	0
4	lane 4_Eb_Empty_Mode	RO	Lane 4_Eb_Empty_Mode External Control from EEPROM.	Yes/No	0
5	lane 5_Eb_Empty_Mode	RO	Lane 5_Eb_Empty_Mode External Control from EEPROM.	Yes/No	0
6	lane 6_Eb_Empty_Mode	RO	Lane 6_Eb_Empty_Mode External Control from EEPROM.	Yes/No	0

BIT	FUNCTION	TYPE	DESCRIPTION	EEPROM/ I2C-SMBUS	DEFAULT
7	lane 7_Eb_Empty_Mode	RO	Lane 7_Eb_Empty_Mode External Control from EEPROM.	Yes/No	0
8	lane 8_Eb_Empty_Mode	RO	Lane 8_Eb_Empty_Mode External Control from EEPROM.	Yes/No	0
9	lane 9_Eb_Empty_Mode	RO	Lane 9_Eb_Empty_Mode External Control from EEPROM.	Yes/No	0
10	lane 10_Eb_Empty_Mode	RO	Lane 10_Eb_Empty_Mode External Control from EEPROM.	Yes/No	0
11	lane 11_Eb_Empty_Mode	RO	Lane 11_Eb_Empty_Mode External Control from EEPROM.	Yes/No	0
12	lane 12_Eb_Empty_Mode	RO	Lane 12_Eb_Empty_Mode External Control from EEPROM.	Yes/No	0
13	lane 13_Eb_Empty_Mode	RO	Lane 13_Eb_Empty_Mode External Control from EEPROM.	Yes/No	0
14	lane 14_Eb_Empty_Mode	RO	Lane 14_Eb_Empty_Mode External Control from EEPROM.	Yes/No	0
15	lane 15_Eb_Empty_Mode	RO	Lane 15_Eb_Empty_Mode External Control from EEPROM..	Yes/No	0
30:16	Rsvrd	RsvdP	Not support.	No	0-0b
31	Eb_Empty_Mode External Control En	RO	Device Cmm Refclk Mode External Control Enble.	Yes/No	0

9.4.174 DEVICE MISC REGISTER – OFFSET 544h (Port 0 Only)

BIT	FUNCTION	TYPE	DESCRIPTION	EEPROM/ I2C-SMBUS	DEFAULT
0	HW_Init_Load	RO	When set, it means eeprom preloading is done.	Yes/No	0
31:1	Rsvrd	RsvdP	Not support.	No	0-0b

9.4.175 SWITCH DOMAIN MODE CONTROL – OFFSET 558h (Port 0 Only)

BIT	FUNCTION	TYPE	DESCRIPTION	EEPROM/ I2C-SMBUS	DEFAULT
7:0	Reserved	RsvdP	Not support.	No	01h
13:8	Broadcast idx	RW	Used to enable destination switch for broadcast message.	Yes	00_0011b
31:14	Reserved	RsvdP	Not support.	No	0-0h

9.4.176 PORT CLOCK CONTROL REGISTER – OFFSET 55Ch (Port 0 Only)

BIT	FUNCTION	TYPE	DESCRIPTION	EEPROM/ I2C-SMBUS	DEFAULT
0	Reserved	RsvdP	Not support.	No	0b
1	Fix_Bifurcation	RO	Used to fix the bifurcation result according to bit[7:4] or bit[11:8]. For manual bifurcation, both of bit0 and bit1 must be set to “1”.	Yes	0b
7:2	Rsvrd	RsvdP	Not support.	No	0-0b

BIT	FUNCTION	TYPE	DESCRIPTION	EEPROM/ I2C-SMBUS	DEFAULT
11:8	Fix_416_result	RO	port_cfg set to 4444 mode. 0000b: set bifurcation result to 416(4444) 0001b: set bifurcation result to 516A(44422) 0010b: set bifurcation result to 516B(44224) 0011b: set bifurcation result to 516C(42244) 0100b: set bifurcation result to 516D(22444) 0101b: set bifurcation result to 616A(442222) 0110b: set bifurcation result to 616B(422422) 0111b: set bifurcation result to 616C(224422) 1000b: set bifurcation result to 616D(422224) 1001b: set bifurcation result to 616E(224224) 1010b: set bifurcation result to 616F(222244) 1011b: set bifurcation result to 716A(4222222) 1100b: set bifurcation result to 716B(2242222) 1101b: set bifurcation result to 716C(2222422) 1110b: set bifurcation result to 716D(2222224) 1111b: set bifurcation result to 816(2222222)	Yes	0
12	Port0_auto_bifu_En	RO	0b: auto bifurcation for port 0 is disabled 1b: auto bifurcation for port 0 is enabled	Yes	0
13	Port2_auto_bifu_En	RO	0b: auto bifurcation for port 2 is disabled 1b: auto bifurcation for port 2 is enabled	Yes	0
14	Port4_auto_bifu_En	RO	0b: auto bifurcation for port 4 is disabled 1b: auto bifurcation for port 4 is enabled	Yes	0
15	Port6_auto_bifu_En	RO	0b: auto bifurcation for port 6 is disabled 1b: auto bifurcation for port 6 is enabled	Yes	0
16	Port Clock control Enable	RW	Used to enable Port Clock control function.	Yes	0
23:17	Rsvrd	RsvdP	Not support.	No	0-0h
31:24	Port Clock Enable	RW	Used to set Port0~Port7 Port Clock Enable. These bits are valid when bit[16]=1.	Yes	FFh

9.4.177 PERFORMANCE COUNTER CONTROL REGISTER – OFFSET 56Ch

BIT	FUNCTION	TYPE	DESCRIPTION	EEPROM/ I2C-SMBUS	DEFAULT
0	counter_start_stop	RW	1b: Performance counter start counting 0b: Performance counter stop counting	Yes	0
1	counter_clear	WO	1b: clear performance counter. It is valid when bit[4]=1 and is always read as 0b.	Yes	0
3:2	Reserved	RsvdP	Not support.	No	00b
4	counter_enable	RW	1b: Performance counter is controlled by s/w (bit[0]) 0b: Performance counter is controlled by h/w (autorun)	No	0
31:5	Reserved	RsvdP	Not support.	No	0-0h

9.4.178 PHY SOURCE SELECT REGISTER – OFFSET 570h

BIT	FUNCTION	TYPE	DESCRIPTION	EEPROM/ I2C-SMBUS	DEFAULT
7:0	Lanexx phy_source select	RW	Internal used only.	Yes	00h
8	Valid for bit[7:1]	RW	1b: bit[7:0] are valid.	Yes	0
31:9	Reserved	RsvdP	Not support.	No	0-0h

9.4.179 NIC CTRL 0 REGISTER – OFFSET 5A0h (Port 0 Only)

BIT	FUNCTION	TYPE	DESCRIPTION	EEPROM/ I2C-SMBUS	DEFAULT
7:0	Debug Select	RW	Select Debug Nic Signal.	Yes	00h
9:8	Cmd Arbiter Delay	RW	Delay cycles for next cmd arbiter start.	Yes	00b

BIT	FUNCTION	TYPE	DESCRIPTION	EEPROM/ I2C-SMBUS	DEFAULT
15:10	Reserved	RW	Internal used only.	Yes	0000_00b
16	Destination Credit Wait	RW	Wait until destination credit is enough to transmit packet. 0b: OFF 1b: ON	Yes	0
17	Reserved	RsvdP	Not support.	No	0
20:18	Time Based RR Time Period	RW	Time Period Selection for Time based Round Robin.	Yes	000b
23:21	Reserved	RW	Internal used only.	No	000b
31:24	Reserved	RsvdP	Not support.	No	00h

9.4.180 NIC CTRL 1 REGISTER – OFFSET 5A4h (Port 0 Only)

BIT	FUNCTION	TYPE	DESCRIPTION	EEPROM/ I2C-SMBUS	DEFAULT
31:0	Reserved	RsvdP	Not support.	No	0000_0000h

9.4.181 NIC CTRL 2 REGISTER – OFFSET 5A8h (Port 0 Only)

BIT	FUNCTION	TYPE	DESCRIPTION	EEPROM/ I2C-SMBUS	DEFAULT
1:0	NIC Router Arbiter Delay	RW	Delay cycles for next arbiter start.	Yes	00b
2	NIC Out Router Arbiter Delay	RW	Delay cycles for next arbiter start.	Yes	1
3	msic	RW	Internal used only.	Yes	0
6:4	noc_buffer_empty for speed up	RW	Internal used only.	Yes	010b
7	nic_speed_up_en	RW	Internal used only.	Yes	0
15:8	Reserved	RsvdP	Not support.	No	00h
18:16	Adaptive Weight RR Period	RW	Time Period Selection for Adaptive Weight Round Robin.	Yes	000b
21:19	Adaptive Weight Ignore Period	RW	Time Period Selection for Reduce Weights of Round Robin.	Yes	000b
22	phase_tag_arbiter_en	RW	Internal used only.	Yes	0
23	Reserved	RsvdP	Not support.	No	0
28:24	phase_tag_timer	RW	Internal used only.	Yes	0_0010b
31:29	Reserved	RsvdP	Not support	No	000b

9.4.182 NIC CTRL 3 REGISTER – OFFSET 5ACh (Port 0 Only)

BIT	FUNCTION	TYPE	DESCRIPTION	EEPROM/ I2C-SMBUS	DEFAULT
31:0	Reserved	RsvdP	Not support.	No	0000_0000h

9.4.183 NIC CTRL 4 REGISTER – OFFSET 5B0h (Port 0 Only)

BIT	FUNCTION	TYPE	DESCRIPTION	EEPROM/ I2C-SMBUS	DEFAULT
31:0	Reserved	RsvdP	Not support.	No	0000_0000h

9.4.184 CR RW CTRL AND STATUS REGISTER – OFFSET 5C0h (Port 0 Only)

BIT	FUNCTION	TYPE	DESCRIPTION	EEPROM/ I2C-SMBUS	DEFAULT
0	Write Enable for Lane 3-0	RW	Write enable bit for Lane 3-0.	No/Yes	0
1	Write Enable for Lane 7-4	RW	Write enable bit for Lane 7-4.	No/Yes	0

BIT	FUNCTION	TYPE	DESCRIPTION	EEPROM/ I2C-SMBUS	DEFAULT
2	Write Enable for Lane 11-8	RW	Write enable bit for Lane 11-8.	No/Yes	0
3	Write Enable for Lane 15-12	RW	Write enable bit for Lane 15-12.	No/Yes	0
7:4	Reserved	RsvdP	Not support.	No	0h
8	Read Enable for Lane 3-0	RW	Read enable bit for Lane 3-0.	No/Yes	0
9	Read Enable for Lane 7-4	RW	Read enable bit for Lane 7-4.	No/Yes	0
10	Read Enable for Lane 11-8	RW	Read enable bit for Lane 11-8.	No/Yes	0
11	Read Enable for Lane 15-12	RW	Read enable bit for Lane 15-12.	No/Yes	0
15:12	Reserved	RsvdP	Not support.	No	0h
19:16	RW Ready Status	RO	Indicates whether Lane 3-0, Lane 7-4, Lane 11-8 or Lane 15-12 is ready for the Read or Write cycle.	No	1111h
31:20	Reserved	RsvdP	Not support.	No	000h

9.4.185 CR CTRL 0 REGISTER – OFFSET 5C4h (Port 0 Only)

BIT	FUNCTION	TYPE	DESCRIPTION	EEPROM/ I2C-SMBUS	DEFAULT
15:0	Lane 3-0 Data	RW	Contains the Lane 3-0 register data.	Yes	0000h
31:16	Lane 3-0 Register	RW	Contains the Lane 3-0 register address.	Yes	0000h

9.4.186 CR CTRL 1 REGISTER – OFFSET 5C8h (Port 0 Only)

BIT	FUNCTION	TYPE	DESCRIPTION	EEPROM/ I2C-SMBUS	DEFAULT
15:0	Lane 7-4 Data	RW	Contains the Lane 7-4 register data.	Yes	0000h
31:16	Lane 7-4 Register	RW	Contains the Lane 7-4 register address.	Yes	0000h

9.4.187 CR CTRL 2 REGISTER – OFFSET 5CCh (Port 0 Only)

BIT	FUNCTION	TYPE	DESCRIPTION	EEPROM/ I2C-SMBUS	DEFAULT
15:0	Lane 11-8 Data	RW	Contains the Lane 11-8 register data.	Yes	0000h
31:16	Lane 11-8 Register	RW	Contains the Lane 11-8 register address.	Yes	0000h

9.4.188 CR CTRL 3 REGISTER – OFFSET 5D0h (Port 0 Only)

BIT	FUNCTION	TYPE	DESCRIPTION	EEPROM/ I2C-SMBUS	DEFAULT
15:0	Lane 15-12 Data	RW	Contains the Lane 15-12 register data.	Yes	0000h
31:16	Lane 15-12 Register	RW	Contains the Lane 15-12 register address.	Yes	0000h

9.4.189 THERMAL SENSOR TEST REGISTER – OFFSET 5D4h (Port 0 Only)

BIT	FUNCTION	TYPE	DESCRIPTION	EEPROM/ I2C-SMBUS	DEFAULT
3:0	Thermal Sensor Test Access Control	RW	Select Thermal Sensor Test Items.	Yes	0h
5:4	Thermal Sensor Chip Select	RW	Chip Select for Thermal Sensor Test. 00b: Thermal Sensor 0 01b: Thermal Sensor 1 10b: Thermal Sensor 2 11b: Reserved	Yes	00b

BIT	FUNCTION	TYPE	DESCRIPTION	EEPROM/ I2C-SMBUS	DEFAULT
6	Software Digital Test Mode	RW	Digital Test Enable. 0b: Disable 1b: Enable	Yes	0
7	Reserved	RsvdP	Not support.	No	0
8	Digital Test Status	RO	Indicate Success or Fail Status of Digital Test. 0b: Fail 1b: Success	No	0
9	Digital Test Mode 8 Status	RO	Indicate Success or Fail Status of Digital Test Mode 8. 0b: Fail 1b: Success	No	0
10	Digital Test Mode 9 Status	RO	Indicate Success or Fail Status of Digital Test Mode 9. 0b: Fail 1b: Success	No	0
14:11	Reserved	RsvdP	Not support.	No	0h
15	Digital Test Done	RO	Thermal Sensor Digital Test Done Status. 0b: Test no complete 1b: Test complete	No	0
16	EEPROM Single Read	RW	Internal used only.	No	0
31:17	Reserved	RsvdP	Not support.	No	0000h

9.4.190 THERMAL SENSOR CTRL 0 REGISTER – OFFSET 5D8h (Port 0 Only)

BIT	FUNCTION	TYPE	DESCRIPTION	EEPROM/ I2C-SMBUS	DEFAULT
0	Thermal Sensor Burst Run	RW	Get Thermal Result periodically. 0b: OFF 1b: ON	Yes	0
1	Thermal Sensor Single Run	RW	Get Thermal Result Once. 0b: OFF 1b: ON	Yes	0
2	Thermal Sensor Power Down	RW	Trun off Thermal Sensor. 0b: disable power down 1b: enable power down	Yes	0
7:3	Reserved	RsvdP	Not support.	No	0_0b
19:8	Thermal Sensor Conversion Data Output	RO	Thermal Sensor Results.	No	000h
22:20	Reserved	RsvdP	Not support.	No	000b
23	Thermal Sensor Conversion Done	RO	Get Thermal Sensor Result Done. 0b: Conversion not complete 1b: Conversion complete	No	0
31:24	Reserved	RsvdP	Not support.	No	00h

9.4.191 THERMAL SENSOR CTRL 1 REGISTER – OFFSET 5DCh (Port 0 Only)

BIT	FUNCTION	TYPE	DESCRIPTION	EEPROM/ I2C-SMBUS	DEFAULT
0	Thermal Sensor Burst Run	RW	Get Thermal Result periodically. 0b: OFF 1b: ON	Yes	0

BIT	FUNCTION	TYPE	DESCRIPTION	EEPROM/ I2C-SMBUS	DEFAULT
1	Thermal Sensor Single Run	RW	Get Thermal Result Once. 0b: OFF 1b: ON	Yes	0
2	Thermal Sensor Power Down	RW	Trun off Thermal Sensor. 0b: disable power down 1b: enable power down	Yes	0
7:3	Reserved	RsvdP	Not support.	No	0_0b
19:8	Thermal Sensor Conversion Data Output	RO	Thermal Sensor Result.	No	000h
22:20	Reserved	RsvdP	Not support.	No	000b
23	Thermal Sensor Conversion Done	RO	Get Thermal Sensor Result Done. 0b: Conversion not complete 1b: Conversion complete	No	0
31:24	Reserved	RsvdP	Not support.	No	00h

9.4.192 THERMAL SENSOR CTRL 2 REGISTER – OFFSET 5E0h (Port 0 Only)

BIT	FUNCTION	TYPE	DESCRIPTION	EEPROM/ I2C-SMBUS	DEFAULT
0	Thermal Sensor Burst Run	RW	Get Thermal Result periodically. 0b: OFF 1b: ON	Yes	0
1	Thermal Sensor Single Run	RW	Get Thermal Result Once. 0b: OFF 1b: ON	Yes	0
2	Thermal Sensor Power Down	RW	Trun off Thermal Sensor. 0b: disable power down 1b: enable power down	Yes	0
7:3	Reserved	RsvdP	Not support.	No	0_0b
19:8	Thermal Sensor Conversion Data Output	RO	Thermal Sensor Result.	No	000h
22:20	Reserved	RsvdP	Not support.	No	000b
23	Thermal Sensor Conversion Done	RO	Get Thermal Sensor Result Done. 0b: Conversion not complete 1b: Conversion complete	No	0
31:24	Reserved	RsvdP	Not support.	No	00h

9.4.193 INGRESS COMPLETION TLP PACKET COUNT[31:0] REGISTER – OFFSET 600h

BIT	FUNCTION	TYPE	DESCRIPTION	EEPROM/ I2C-SMBUS	DEFAULT
31:0	Ingress Completion TLP Packet Count [31:0]	RC	Records received completion TLP packet count[31:0].	No	0000_0000h

9.4.194 INGRESS COMPLETION TLP PACKET COUNT[47:32] REGISTER – OFFSET 604h

BIT	FUNCTION	TYPE	DESCRIPTION	EEPROM/ I2C-SMBUS	DEFAULT
15:0	Ingress Completion TLP Packet Count [47:32]	RC	Records received completion TLP packet count[47:32].	No	0000h
31:16	Reserved	RsvdP	Not support.	No	0000h

9.4.195 INGRESS COMPLETION TLP PAYLOAD BYTE COUNT[31:0] REGISTER – OFFSET 608h

BIT	FUNCTION	TYPE	DESCRIPTION	EEPROM/ I2C-SMBUS	DEFAULT
31:0	Ingress Completion TLP Payload Byte Count Count[31:0]	RC	Records received completion TLP payload byte count[31:0].	No	0000_0000h

9.4.196 INGRESS COMPLETION TLP PAYLOAD BYTE COUNT[47:32] REGISTER – OFFSET 60Ch

BIT	FUNCTION	TYPE	DESCRIPTION	EEPROM/ I2C-SMBUS	DEFAULT
15:0	Ingress Completion TLP Payload Byte Count[47:32]	RC	Records received completion TLP payload byte count[47:32].	No	0000h
31:16	Reserved	RsvdP	Not support.	No	0000h

9.4.197 INGRESS POST TLP PACKET COUNT[31:0] REGISTER – OFFSET 610h

BIT	FUNCTION	TYPE	DESCRIPTION	EEPROM/ I2C-SMBUS	DEFAULT
31:0	Ingress Post TLP Packet Count[31:0]	RC	Records received post TLP packet count[31:0].	No	0000_0000h

9.4.198 INGRESS POST TLP PACKET COUNT[47:32] REGISTER – OFFSET 614h

BIT	FUNCTION	TYPE	DESCRIPTION	EEPROM/ I2C-SMBUS	DEFAULT
15:0	Ingress Post TLP Packet Count[47:32]	RC	Records received post TLP packet count[47:32].	No	0000h
31:16	Reserved	RsvdP	Not support.	No	0000h

9.4.199 INGRESS POST TLP PAYLOAD BYTE COUNT[31:0] REGISTER – OFFSET 618h

BIT	FUNCTION	TYPE	DESCRIPTION	EEPROM/ I2C-SMBUS	DEFAULT
31:0	Ingress Post TLP Payload Byte Count [31:0]	RC	Records received post TLP payload byte count[31:0].	No	0000_0000h

9.4.200 INGRESS POST TLP PAYLOAD BYTE COUNT[47:32] REGISTER – OFFSET 61Ch

BIT	FUNCTION	TYPE	DESCRIPTION	EEPROM/ I2C-SMBUS	DEFAULT
15:0	Ingress Post TLP Payload Byte Count [47:32]	RC	Records received post TLP payload byte count[47:32].	No	0000h
31:16	Reserved	RsvdP	Not support.	No	0000h

9.4.201 INGRESS BAD TLP PACKET COUNT[31:0] REGISTER – OFFSET 620h

BIT	FUNCTION	TYPE	DESCRIPTION	EEPROM/ I2C-SMBUS	DEFAULT
31:0	Ingress Error TLP Payload Byte Count [31:0]	RC	Records received error TLP packet count bit[31:0]. The counter is increased by one as receiving a TLP contaminated with errors that are enabled in ingress error counter enable register at offset 67Ch	No	0000_0000h

9.4.202 INGRESS NON-POST TLP PACKET COUNT[31:0] REGISTER – OFFSET 628h

BIT	FUNCTION	TYPE	DESCRIPTION	EEPROM/ I2C-SMBUS	DEFAULT
31:0	Ingress Non-Post TLP Packet Count [31:0]	RC	Records received non-post TLP packet count[31:0].	No	0000_0000h

9.4.203 INGRESS NON-POST TLP PACKET COUNT[47:32] REGISTER – OFFSET 62Ch

BIT	FUNCTION	TYPE	DESCRIPTION	EEPROM/ I2C-SMBUS	DEFAULT
15:0	Ingress Non-Post TLP Packet Count [47:32]	RC	Records received non-post TLP packet count[47:32].	No	0000h
31:16	Reserved	RsvdP	Not support.	No	0000h

9.4.204 EGRESS COMPLETION TLP PACKET COUNT[31:0] REGISTER - OFFSET 630h

BIT	FUNCTION	TYPE	DESCRIPTION	EEPROM/ I2C-SMBUS	DEFAULT
31:0	Egress Completion TLP Packet Count [31:0]	RC	Records transmit completion TLP packet count[31:0].	No	0000_0000h

9.4.205 EGRESS COMPLETION TLP PACKET COUNT[47:32] REGISTER – OFFSET 634h

BIT	FUNCTION	TYPE	DESCRIPTION	EEPROM/ I2C-SMBUS	DEFAULT
15:0	Egress Completion TLP Packet Count [47:32]	RC	Records transmit completion TLP packet count[47:32].	No	0000h
31:16	Reserved	RsvdP	Not support.	No	0000h

9.4.206 EGRESS COMPLETION TLP PAYLOAD BYTE COUNT[31:0] REGISTER – OFFSET 638h

BIT	FUNCTION	TYPE	DESCRIPTION	EEPROM/ I2C-SMBUS	DEFAULT
31:0	Egress Completion TLP Payload Byte Count[31:0]	RC	Records transmit completion TLP payload byte count[31:0].	No	0000_0000h

9.4.207 EGRESS COMPLETION TLP PAYLOAD BYTE COUNT[47:32] REGISTER – OFFSET 63Ch

BIT	FUNCTION	TYPE	DESCRIPTION	EEPROM/ I2C-SMBUS	DEFAULT
15:0	Egress Completion TLP Payload Byte Count[47:32]	RC	Records transmit completion TLP payload byte count[47:32].	No	0000h
31:16	Reserved	RsvdP	Not support.	No	0000h

9.4.208 EGRESS POST TLP PACKET COUNT[31:0] REGISTER – OFFSET 640h

BIT	FUNCTION	TYPE	DESCRIPTION	EEPROM/ I2C-SMBUS	DEFAULT
31:0	Egress Post TLP Packet Count[31:0]	RC	Records transmit post TLP packet count[31:0]	No	0000_0000h

9.4.209 EGRESS POST TLP PACKET BYTE COUNT[47:32] REGISTER – OFFSET 644h

BIT	FUNCTION	TYPE	DESCRIPTION	EEPROM/ I2C-SMBUS	DEFAULT
15:0	Egress Post TLP Packet Count[47:32]	RC	Records transmit post TLP packet count[47:32].	No	0000h
31:16	Reserved	RsvdP	Not support.	No	0000h

9.4.210 EGRESS POST TLP PAYLOAD BYTE COUNT[31:0] REGISTER – OFFSET 648h

BIT	FUNCTION	TYPE	DESCRIPTION	EEPROM/ I2C-SMBUS	DEFAULT
31:0	Egress Post TLP Payload Byte Count [31:0]	RC	Records transmit post TLP payload byte count[31:0].	No	0000_0000h

9.4.211 EGRESS POST TLP PAYLOAD BYTE COUNT[47:32] REGISTER – OFFSET 64Ch

BIT	FUNCTION	TYPE	DESCRIPTION	EEPROM/ I2C-SMBUS	DEFAULT
8:0	Egress Post TLP Payload Byte Count [47:32]	RC	Records transmit post TLP payload byte count[47:32].	No	0000h
31:15	Reserved	RsvdP	Not support.	No	0000h

9.4.212 EGRESS ERROR TLP PACKET COUNT[15:0] REGISTER – OFFSET 650h

BIT	FUNCTION	TYPE	DESCRIPTION	EEPROM/ I2C-SMBUS	DEFAULT
15:0	Egress Error TLP Payload Byte Count [15:0]	RC	Records transmit error TLP packet count[15:0]. A switch internal error such as ECC non-correctable error is detected when the packet reaches an egress port.	No	0000h

9.4.213 EGRESS ERROR TLP PAYLOAD BYTE COUNT[47:32] REGISTER – OFFSET 654h

BIT	FUNCTION	TYPE	DESCRIPTION	EEPROM/ I2C-SMBUS	DEFAULT
8:0	Egress Error TLP Payload Byte Count [47:32]	RC	Records transmit error TLP payload byte count[47:32].	No	0000h
31:15	Reserved	RsvdP	Not support.	No	0000h

9.4.214 EGRESS NON-POST TLP PACKET COUNT[31:0] REGISTER – OFFSET 658h

BIT	FUNCTION	TYPE	DESCRIPTION	EEPROM/ I2C-SMBUS	DEFAULT
31:0	Egress Non-Post TLP Packet Count [31:0]	RC	Records transmit non-post TLP packet count[31:0].	No	0000_0000h

9.4.215 EGRESS NON-POST TLP PACKET COUNT[47:32] REGISTER – OFFSET 65Ch

BIT	FUNCTION	TYPE	DESCRIPTION	EEPROM/ I2C-SMBUS	DEFAULT
15:0	Egress Non-Post TLP Packet Count[47:32]	RC	Records transmit non-post TLP packet count bit[47:32].	No	0000h
31:16	Reserved	RsvdP	Not support.	No	0000h

9.4.216 TL/DLL/MAC/PHY ERROR TYPE SEL REGISTER – OFFSET 660h

BIT	FUNCTION	TYPE	DESCRIPTION	EEPROM/ I2C-SMBUS	DEFAULT
7:0	Reg_664h_Sel	RW	bit[1:0]: Reg_664h_Sel_Type 00b... Reg_664h_Sel[7:2] are used as dll_mac_err_sel_0[5:0] 01b... Reg_664h_Sel[7:2] are used as tl_err_sel_0[5:0] 10b... Reg_664h_Sel[7:2] are used as noc_err_sel_0[5:0] 11b...Reserved	Yes	FEh

BIT	FUNCTION	TYPE	DESCRIPTION	EEPROM/ I2C-SMBUS	DEFAULT
7:0	Reg_664h_Sel	RW	<p>dll_mac_err_sel_x[5:0] (x=0, 1 or 2):</p> <p>00h... seq_err 01h... fcfail_retrain 02h... retry_buffer_full 03h... retry_buffer_ecc_one_bit_error 04h... retry_buffer_ecc_two_bit_error 05h... tx_nullify 06h... replay_timer_expired 07h... replay_no_roll_over 08h... retrain_link 09h... nack_seq_err 0Ah... tlp_tx_fifo_length_error (tlp_tx_protocol_error (redundant sof/eof, length error...)) 0Bh... tlp_tx_fifo_abort 0Ch... tlp_tx_header_error 0Dh... tlp_tx_no_eof_error 0Eh... crc16_error 0Fh... crc32_error 10h... nullify_crc_detect 11h... receive_packet_abort(tlp_rx_abort = 1) 12h... receive_nack 13h... framing_error 14h... retrain_link 15h... recv_ts_speed_change 16h... recv_hot_reset_bit 17h... recv_disable_link 18h... recv_loopback 19h... recv_dis_screamb 1Ah... recv_comp 1Bh... goto_retrain_by_MAC 1Ch... goto_retrain_by_DUT_LTSSM 1Dh... goto_retrain_by_root 1Eh... PHY_status_error 1Fh~3Eh... reserved</p> <p>3Fh... wire or errors that corresponding mask bit set to 0 in TL/DLL/MAC/PHY ERROR MASK 0 register</p> <p>tl_err_sel_x[5:0] (x=0, 1 or 2):</p> <p>00h... TL_ERR_STA[0] 01h... TRAIN_ERR_SET 02h... DLLP_ERR_SET 03h... RX_ERR_SET 04h... BAD_TLP_SET 05h... BAD_DLLP_SET 06h... REPLAY_ROLLOVER_SET 07h... REPLAY_TIMEOUT_SET 08h... UR_ERR_SET_all 09h... ECRC_ERR_SET_all 0Ah... MF_TLP_ERR_SET_all 0Bh... RX_OVERFLOW_SET 0Ch... UC_STS_SET_all 0Dh... FC_ERR_SET_all 0Eh... POISON_TLP_SET_all 0Fh... TL_ECC[0] (P/NP/CPLD buffer 1 bit ecc error OR) 10h... TL_ECC[1] (P/NP/CPLD buffer 1 bit ecc error OR) 11h~12h... Reserved 13h... TL_ERR_STA[1] 14h... TL_ERR_STA[2] 15h... TL_ERR_STA[3] 16h~3Eh... Reserved</p> <p>3Fh... wire or errors that corresponding mask bit set to 0 in TL/DLL/MAC/PHY ERROR MASK 0 register</p>	Yes	FEh

BIT	FUNCTION	TYPE	DESCRIPTION	EEPROM/ I2C-SMBUS	DEFAULT
7:0	Reg_664h_Sel	RW	noc_err_sel_x[5:0] (x=0, 1 or 2): 00h~01h... r_buffer one/two bit ecc error 02h~03h... v_buffer one/two bit ecc error 04h~05h... l_buffer one/two bit ecc error 06h~07h... d_buffer one/two bit ecc error 08h~09h... dma noc_r_buffer one/two bit ecc error 0Ah~0Bh... dma noc_v_buffer one/two bit ecc error 0Ch~0Dh... dma noc_l_buffer one/two bit ecc error 0Eh~0Fh... dma noc_d_buffer one/two bit ecc error 10h~1Dh... reserved 1Eh... eeprom_done 1Fh... strapin_transfer_time_out 20h~3Eh... reserved 3Fh... wire or errors that corresponding mask bit set to 0 in TL/DLL/MAC/PHY ERROR MASK 0 register	Yes	FEh
15:8	Reg_668h_Sel	RW	bit[1:0]: Reg_668h_Sel_Type. 00b... Reg_668h_Sel[15:10] are used as dll_mac_err_sel_1[5:0] 01b... Reg_668h_Sel[15:10] are used as tl_err_sel_1[5:0] 10b... Reg_668h_Sel[15:10] are used as noc_err_sel_1[5:0] 11b...Reserved If Reg_668h_Sel[15:10] = 3Fh, wire or errors that corresponding mask bit set to 0 in TL/DLL/MAC/PHY ERROR MASK 1 register	Yes	FDh
23:16	Reg_66Ch_Sel	RW	bit[1:0]: Reg_66Ch_Sel_Type. 00b... Reg_66Ch_Sel[23:18] are used as dll_mac_err_sel_2[5:0] 01b... Reg_66Ch_Sel[23:18] are used as tl_err_sel_2[5:0] 10b... Reg_66Ch_Sel[23:18] are used as noc_err_sel_2[5:0] 11b...Reserved If Reg_66Ch_Sel[23:18] = 3Fh, wire or errors that corresponding mask bit set to 0 in TL/DLL/MAC/PHY ERROR MASK 2 register	Yes	FCh
31:24	Reserved	RsvdP	Not support.	No	00h

9.4.217 TL/DLL/MAC/PHY ERROR COUNT 0 REGISTER – OFFSET 664h

BIT	FUNCTION	TYPE	DESCRIPTION	EEPROM/ I2C-SMBUS	DEFAULT
15:0	TL/DLL/MAC/PHY Error Count 0	RW1C	TL/DLL/MAC/PHY Error count 0.	Yes	0000h

9.4.218 TL/DLL/MAC/PHY ERROR COUNT 1 REGISTER – OFFSET 668h

BIT	FUNCTION	TYPE	DESCRIPTION	EEPROM/ I2C-SMBUS	DEFAULT
15:0	TL/DLL/MAC/PHY Error Count 1	RW1C	TL/DLL/MAC/PHY Error count 1.	Yes	0000h

9.4.219 TL/DLL/MAC/PHY ERROR COUNT 2 REGISTER – OFFSET 66Ch

BIT	FUNCTION	TYPE	DESCRIPTION	EEPROM/ I2C-SMBUS	DEFAULT
15:0	TL/DLL/MAC/PHY Error Count 2	RW1C	TL/DLL/MAC/PHY Error count 2.	Yes	0000h

9.4.220 TL/DLL/MAC/PHY ERROR MASK 0 REGISTER – OFFSET 670h

BIT	FUNCTION	TYPE	DESCRIPTION	EEPROM/ I2C-SMBUS	DEFAULT
31:0	Reg_664 Error Mask	RW	For reg_664_sel[7:2]==6'h3f error mask purpose.	Yes	FFF0_0000h

9.4.221 TL/DLL/MAC/PHY ERROR MASK 1 REGISTER – OFFSET 674h

BIT	FUNCTION	TYPE	DESCRIPTION	EEPROM/ I2C-SMBUS	DEFAULT
31:0	Reg_668 Error Mask	RW	For reg_668_sel[7:2]==6'h3f error mask purpose.	Yes	FB3F_C1FF h

9.4.222 TL/DLL/MAC/PHY ERROR MASK 2 REGISTER – OFFSET 678h

BIT	FUNCTION	TYPE	DESCRIPTION	EEPROM/ I2C-SMBUS	DEFAULT
31:0	Reg_66C Error Mask	RW	For reg_66C_sel[7:2]==6'h3f error mask purpose.	Yes	BFFB_389F h

9.4.223 INGRESS ERROR COUNTER ENABLE REGISTER – OFFSET 67Ch

BIT	FUNCTION	TYPE	DESCRIPTION	EEPROM/ I2C-SMBUS	DEFAULT
0	Training Error Enable	RW	When set, the Training Error event is counted in ingress bad TLP packet counter at offset 620H .	Yes	0
1	Reserved	RsvdP	Not support.	No	0
2	MWR Error Enable	RW	When set, the Memory write error event is counted in ingress bad TLP packet counter at offset 620H .	Yes	1
3	MRD Error Enable	RW	When set, the Memory read clpd error event is counted in ingress bad TLP packet counter at offset 620H .	Yes	1
4	Data Link Protocol Error Enable	RW	When set, the Data Link Protocol Error event is counted in ingress bad TLP packet counter at offset 620H .	Yes	0
5	Surprise Down Error Enable	RW	When set, Surprise Down Error event is counted in ingress bad TLP packet counter at offset 620H .	Yes	0
11:6	Reserved	RsvdP	Not support.	Yes	0
12	Poisoned TLP Enable	RW	When set, an event of Poisoned TLP is counted in ingress bad TLP packet counter at offset 620H .	Yes	0
13	Flow Control Protocol Error Enable	RW	When set, the Flow Control Protocol Error event is counted in ingress bad TLP packet counter at offset 620H .	Yes	0
14	Completion Timeout Enable	RW	When set, the Completion Timeout event is counted in ingress bad TLP packet counter at offset 620H .	Yes	0
15	Completer Abort Enable	RW	When set, the Completer Abort event is counted in ingress bad TLP packet counter at offset 620H .	Yes	0
16	Unexpected Completion Enable	RW	When set, the Unexpected Completion event is counted in ingress bad TLP packet counter at offset 620H .	Yes	0
17	Receiver Overflow Enable	RW	When set, the Receiver Overflow event is counted in ingress bad TLP packet counter at offset 620H .	Yes	0
18	Malformed TLP Enable	RW	When set, an event of Malformed TLP is counted in ingress bad TLP packet counter at offset 620H .	Yes	0
19	ECRC Error Enable	RW	When set, an event of ECRC Error is counted in ingress bad TLP packet counter at offset 620H .	Yes	0
20	Unsupported Request Error Enable	RW	When set, the Unsupported Request event is counted in ingress bad TLP packet counter at offset 620H .	Yes	0
21	ACS Violation Enable	RW	When set, the ACS Violation event is counted in ingress bad TLP packet counter at offset 620H .	Yes	0
22	Reserved	RsvdP	Not support.	Yes	0
23	MC Blocked TLP Enable	RW	When set, the MC Blocked TLP event is counted in ingress bad TLP packet counter at offset 620H .	Yes	0
24	AtomicOp Egress Blocked Enable	RW	When set, the AtomicOp Egress Blocked event is counted in ingress bad TLP packet counter at offset 620H .	Yes	0
25	Bad TLP Enable	RW	When set, the event of Bad TLP has been received is counted in ingress bad TLP packet counter at offset 620H .	Yes	0
26	Bad DLLP Enable	RW	When set, the event of Bad DLLP has been received is counted in ingress bad TLP packet counter at offset 620H .	Yes	0
27	REPLAY_NUM Rollover Enable	RW	When set, the REPLAY_NUM Rollover event is counted in ingress bad TLP packet counter at offset 620H .	Yes	0
28	Replay Timer Timeout Enable	RW	When set, the Replay Timer Timeout event is counted in ingress bad TLP packet counter at offset 620H .	Yes	0

BIT	FUNCTION	TYPE	DESCRIPTION	EEPROM/ I2C-SMBUS	DEFAULT
29	Advisory Non-Fatal Error Enable	RW	When set, the Advisory Non-Fatal Error event is counted in ingress bad TLP packet counter at offset 620H .	Yes	0
30	One bit ECC Error Enable	RW	When set, the One-bit ECC Error event is counted in ingress bad TLP packet counter at offset 620H .	Yes	0
31	Two bit ECC Error Enable	RW	When set, the Two-bit ECC Error event is counted in ingress bad TLP packet counter at offset 620H .	Yes	1

9.4.224 TRIGGER 1 MASK REGISTER – OFFSET 700h (Port 0 Only)

BIT	FUNCTION	TYPE	DESCRIPTION	EEPROM/ I2C-SMBUS	DEFAULT
31:0	Trigger 1 Mask	RW	Set “1” to enable corresponding offset 708h bits.	Yes	0000_0000h

9.4.225 TRIGGER 2 MASK REGISTER – OFFSET 704h (Port 0 Only)

BIT	FUNCTION	TYPE	DESCRIPTION	EEPROM/ I2C-SMBUS	DEFAULT
31:0	Trigger 2 Mask	RW	Set “1” to enable corresponding offset 70Ch bits.	Yes	0000_0000h

9.4.226 PATTERN 1 SETTING REGISTER – OFFSET 708h (Port 0 Only)

BIT	FUNCTION	TYPE	DESCRIPTION	EEPROM/ I2C-SMBUS	DEFAULT
31:0	Pattern 1 Setting	RW	Set bit[31:0] pattern to match internal selected debug_out[31:0] by offset 710h .	Yes	0000_0000h

9.4.227 PATTERN 2 SETTING REGISTER – OFFSET 70Ch (Port 0 Only)

BIT	FUNCTION	TYPE	DESCRIPTION	EEPROM/ I2C-SMBUS	DEFAULT
31:0	Pattern 2 Setting	RW	Set bit[31:0] pattern to match internal selected debug_out[31:0] by offset 714h .	Yes	0000_0000h

9.4.228 TRIGGER 1 DEBUG_OUT MODE SELECTION REGISTER – OFFSET 710h (Port 0 Only)

BIT	FUNCTION	TYPE	DESCRIPTION	EEPROM/ I2C-SMBUS	DEFAULT
4:0	Mode 1 Setting	RW	Used as debug_out mode_sel[4:0]. When offset 390h , bit[31]=0 (embedded LA) bit[4]=0, used for MAC debug out signals bit[4]=1 and bit[3:0]=0~14 are used for TLP debug out signals bit[4]=1 and bit[3:0]=15 are used for power saving debug signals When offset 390h , bit[31]=1 (LTSSM flow) bit[4] is used to reset read/write counter	Yes	0_0000b
7:5	Reserved	RsvdP	Not support.	No	000b
13:8	Trigger 1 port Selection	RW	Used to set trigger 1 port.	Yes	00_0000b
31:14	Reserved	RsvdP	Not support.	No	0_0h

9.4.229 TRIGGER 2 DEBUG_OUT MODE SELECTION REGISTER – OFFSET 714h (Port 0 Only)

BIT	FUNCTION	TYPE	DESCRIPTION	EEPROM/ I2C-SMBUS	DEFAULT
4:0	Mode 2 Setting	RW	Used as debug_out mode_sel[4:0].	Yes	0_0000b

BIT	FUNCTION	TYPE	DESCRIPTION	EEPROM/ I2C-SMBUS	DEFAULT
7:5	Reserved	RsvdP	Not support.	No	000b
13:8	Trigger 2 port selection	RW	Used to set trigger 2 port.	Yes	00_0000b
31:14	Reserved	RsvdP	Not support.	No	0_0h

9.4.230 TRIGGER 1 AND/OR CONDITION SELECTION REGISTER – OFFSET 718h (Port 0 Only)

BIT	FUNCTION	TYPE	DESCRIPTION	EEPROM/ I2C-SMBUS	DEFAULT
0	And/Or Select 1	RW	0b: OR logical for trigger 1 1b: AND logical for trigger 1	Yes	1
31:1	Reserved	RsvdP	Not support.	No	0_0h

9.4.231 TRIGGER 2 AND/OR CONDITION SELECTION REGISTER – OFFSET 71Ch (Port 0 Only)

BIT	FUNCTION	TYPE	DESCRIPTION	EEPROM/ I2C-SMBUS	DEFAULT
0	And/Or Select 2	RW	0b: OR logical for trigger 1 1b: AND logical for trigger 1	Yes	1
31:1	Reserved	RsvdP	Not support.	No	0_0h

9.4.232 TRIGGER SELECT REGISTER – OFFSET 720h (Port 0 Only)

BIT	FUNCTION	TYPE	DESCRIPTION	EEPROM/ I2C-SMBUS	DEFAULT
2:0	Trigger Select	RW	000b: select offset 708h trigger pattern as trigger 001b: select offset 70Ch trigger pattern as trigger 010b: select offset 708h and 70Ch trigger patterns as trigger 011b: select offset 708h or 70Ch trigger pattern as trigger 100b: if offset 708h match then go to offset 70Ch trigger pattern Others: Reserved	Yes	000b
7:3	Reserved	RsvdP	Not support.	No	0000_0b
10:8	External port trigger	RW	Internal used only.	Yes	000b
31:11	Reserved	RsvdP	Not support.	No	0_0h

9.4.233 TRIGGER POSITION SELECTION REGISTER – OFFSET 724h (Port 0 Only)

BIT	FUNCTION	TYPE	DESCRIPTION	EEPROM/ I2C-SMBUS	DEFAULT
6:0	Trigger Position Select	RW	Used to select the trigger address, where 00h is from header (0%) and 7Fh is ending (100%).	Yes	20h
31:7	Reserved	RsvdP	Not support.	No	0_0h

9.4.234 TRIGGER COUNTER SETTING REGISTER – OFFSET 72Ch (Port 0 Only)

BIT	FUNCTION	TYPE	DESCRIPTION	EEPROM/ I2C-SMBUS	DEFAULT
3:0	Counter	RW	Used to set trigger amount when trigger achieves the trigger count.	Yes	0h
31:4	Reserved	RsvdP	Not support.	No	0000_000h

9.4.235 TRIGGER START REGISTER – OFFSET 730h (Port 0 Only)

BIT	FUNCTION	TYPE	DESCRIPTION	EEPROM/ I2C-SMBUS	DEFAULT
0	Trigger Start	RW	When set, start the trigger.	Yes	0

BIT	FUNCTION	TYPE	DESCRIPTION	EEPROM/ I2C-SMBUS	DEFAULT
1	Debug_to_use_LA_en	RW	When set, enable debug to use LA.	Yes	0
15:2	Reserved	RsvdP	Not support.	No	0-0b
29:16	Cycle Left	RO	Show how many cycles left.	No	3FFFh
31:30	Reserved	RsvdP	Not support.	No	00b

9.4.236 READ WAVEFORM DATA REGISTER – OFFSET 734h (Port 0 Only)

BIT	FUNCTION	TYPE	DESCRIPTION	EEPROM/ I2C-SMBUS	DEFAULT
31:0	Read Waveform Data	RO	Used to output embedded debug memory data. Total 4096 cycles can be read and read out is in sequence from cycle 0. Each offset 734h read command will advance 1 cycle automatically.	No	0000_0000h

9.4.237 SAMPLE RATE SETTING REGISTER – OFFSET 738h (Port 0 Only)

BIT	FUNCTION	TYPE	DESCRIPTION	EEPROM/ I2C-SMBUS	DEFAULT
3:0	Sample Rate Setting	RW	Used to set the embedded LA sampling rate. 0h: 500MHz sampling rate 1h: 250MHz sampling rate 2h: 125MHz sampling rate ...	Yes	0000_0000h
31:4	Reserved	RsvdP	Not support.	No	0-0h

9.4.238 WAVEFORM OUTPUT PORT SELECT REGISTER – OFFSET 73Ch (Port 0 Only)

BIT	FUNCTION	TYPE	DESCRIPTION	EEPROM/ I2C-SMBUS	DEFAULT
5:0	Waveform Output Port Select	RW	Used to select which port's debug_out[31:0] can be dumped into embedded debug memory.	Yes	00_0000b
7:6	Reserved	RsvdP	Not support.	No	0-0h
12:8	Waveform Output Model_Sel Select	RW	Used to select which model_sel[4:0] debug_out can be dumped into embedded debug memory.	Yes	0-0b
15:13	Reserved	RsvdP	Not support.	No	000b
16	Switch Output Singal Source	RW	When set, it will switch debug_mode GPIO[31:0] output signal source from internal debug_out to debug memory stored debug_out data.	Yes	0
17	Enable User-Defined Mode	RW	When set, it will select internal debug_out port_sel/mode_sel to bit[5:0]/bit[12:8] port_sel/mode_sel value.	Yes	0
18	PORT_GOOD Setting	RW	When set, it will switch PORT_GOOD_L[7:0] output from original link status to internal error status.	Yes	0
31:19	Reserved	RsvdP	Not support.	No	0-0h

9.4.239 WAVEFORM READ EVENT RESET REGISTER – OFFSET 748h (Port 0 Only)

BIT	FUNCTION	TYPE	DESCRIPTION	EEPROM/ I2C-SMBUS	DEFAULT
0	Back to waveform by CFG/I2C/SMBUS	WO	When set, the read point will back to the header of the waveform. Reading returns 0 always.	Yes	0
31:1	Reserved	RsvdP	Not support.	No	0-0h

9.4.240 DUMP MEMORY TO GPIO RATE CONTROL REGISTER – OFFSET 74Ch (Port 0 Only)

BIT	FUNCTION	TYPE	DESCRIPTION	EEPROM/ I2C-SMBUS	DEFAULT
3:0	Dump Waveform to LA Sample Rate Setting	RW	Used to set the debug memory 32 bits data output to GPIO[31:0] rate. 0h: output to GPIO[31:0] as 500MHz clock rate 1h: output to GPIO[31:0] as 250MHz clock rate 2h: output to GPIO[31:0] as 125MHz clock rate ...	Yes	0h
31:4	Reserved	RsvdP	Not support.	No	0-0h

9.4.241 DUMP WAVEFORM START REGISTER – OFFSET 750h (Port 0 Only)

BIT	FUNCTION	TYPE	DESCRIPTION	EEPROM/ I2C-SMBUS	DEFAULT
0	Dump Waveform Start	RW	When set, start to dump waveform to LA.	Yes	0
31:1	Reserved	RsvdP	Not support.	No	0-0h

9.4.242 FREE RUN BUTTON REGISTER – OFFSET 754h (Port 0 Only)

BIT	FUNCTION	TYPE	DESCRIPTION	EEPROM/ I2C-SMBUS	DEFAULT
0	Free Run Button	RW	When set, debug memory will store pre-defined internal debug_out[31:0] data, and output to GPIO[31:0] automatically.	Yes	0
31:1	Reserved	RsvdP	Not support.	No	0-0h

9.4.243 VENDOR SPECIFIC CAPABILITIES REGISTER – OFFSET 900h

BIT	FUNCTION	TYPE	DESCRIPTION	EEPROM/ I2C-SMBUS	DEFAULT
15:0	Extended Capabilities ID	RO	Read as 000Bh to indicate that this is PCI express extended capability register for vendor specific.	No	000Bh
19:16	Capability Version	RO	Read as 1h.	No	1h
31:20	Next Capability Offset	RO	Read as 000h. No other ECP registers.	Yes	000h

9.4.244 VENDOR SPECIFIC HEADER REGISTER – OFFSET 904h

BIT	FUNCTION	TYPE	DESCRIPTION	EEPROM/ I2C-SMBUS	DEFAULT
15:0	VSEC ID	RO	This field is a vendor-defined ID number that indicates the nature and format of the VSEC structure.	No	0001h
19:16	VSEC Rev	RO	This field is a vendor-defined version number that indicates the version of the VSEC structure.	No	0h
31:20	VSEC Length	RO	This field indicates the number of bytes in the entire VSEC structure.	No	280h

9.4.245 BTR 2 REGISTER – OFFSET 908h

BIT	FUNCTION	TYPE	DESCRIPTION	EEPROM/ I2C-SMBUS	DEFAULT
0	3DW Address Space	RW	0b: the translated TLP header is in 4DW format 1b: the translated TLP header is in 3DW format	Yes	0
19:1	Reserved	RsvdP	Not support.	No	0_0000h
31:20	Memory BAR 2 Address Translation	RW	This is the destination base address for Direct Address Translation. Valid when BAR 2 is enabled (offset E8h[31]=1).	Yes	000h

BIT	FUNCTION	TYPE	DESCRIPTION	EEPROM/ I2C-SMBUS	DEFAULT
			Please note that the source base address used in DAT is defined in BAR 2 located at offset 18h.		

9.4.246 BTR 3 REGISTER – OFFSET 90Ch

BIT	FUNCTION	TYPE	DESCRIPTION	EEPROM/ I2C-SMBUS	DEFAULT
17:0	Reserved	RsvdP	E8h[2:1]=00b Not support	Yes	000h
		RW	E8h[2:1]=10b BAR2/3 are used as a 64-bit source BAR, the bit[31:0] are used as the upper 32-bits of destination base address.		
31:18	Memory BAR 3 Address Translation	RW	E8h[2:1]=00b Valid when BAR 3 is enabled (offset ECh[31]=1).	Yes	000h
			E8h[2:1]=10b BAR2/3 are used as a 64-bit source BAR, the bit[31:0] are used as the upper 32-bits of destination base address.		

9.4.247 BTR 4 REGISTER – OFFSET 910h

BIT	FUNCTION	TYPE	DESCRIPTION	EEPROM/ I2C-SMBUS	DEFAULT
0	3DW Address Space	RW	0b: the translated TLP header is in 4DW format 1b: the translated TLP header is in 3DW format	Yes	0
19:1	Reserved	RsvdP	Not support.	No	0_0000h
31:20	Memory BAR 4 Address Translation	RW	This is the destination base address for Direct Address Translation. Valid when BAR 4 is enabled (offset F0h[31]=1). Please note that the source base address used in DAT is defined in BAR 4 located at offset 20h	Yes	000h

9.4.248 BTR 5 REGISTER – OFFSET 914h

BIT	FUNCTION	TYPE	DESCRIPTION	EEPROM/ I2C-SMBUS	DEFAULT
19:0	Reserved	RsvdP	F0h[2:1]=00b Not support.	No/Yes	000h
		RW	F0h[2:1]=10b BAR4/5 are used as a 64-bit source BAR, the bit[31:0] are used as the upper 32-bits of destination base address.		
31:20	Memory BAR 5 Address Translation	RW	F0h[2:1]=00b Valid when BAR 5 is enabled (offset F4h[31]=1).	Yes	000h
			F0h[2:1]=10b BAR4/5 are used as a 64-bit source BAR, the bit[31:0] are used as the upper 32-bits of destination base address.		

9.4.249 ADDRESS LUT ACCESS ADDRESS REGISTER – OFFSET 918h

BIT	FUNCTION	TYPE	DESCRIPTION	EEPROM/ I2C-SMBUS	DEFAULT
6:0	Index	RW	Used to indicate the LUT Entry number. In Generic CDLEP mode, all of entries (128) are allocated for address translation based upon BAR2/3.	Yes	00h
7	Reserved	RsvdP	Not support.	No	0b

BIT	FUNCTION	TYPE	DESCRIPTION	EEPROM/ I2C-SMBUS	DEFAULT
8	Command	WO	0b: Read command 1b: Write command Return '0' when read always.	Yes	0
31:9	Reserved	RsvdP	Not support	No	0-0h

9.4.250 ADDRESS LUT ACCESS DATA 0 REGISTER – OFFSET 91Ch

BIT	FUNCTION	TYPE	DESCRIPTION	EEPROM/ I2C-SMBUS	DEFAULT
0	3DW Address Space	RW	0b: the translated TLP header is in 4DW format 1b: the translated TLP header is in 3DW format	Yes	0
4:1	Domain Number	RW	Used to indicate the destination port's domain number.	Yes	0000b
12:5	Reserved	RsvdP	Not support	No	0-0b
31:13	LUT Data[18:0]	RW	Used to indicate the destination base address for address translation in 32-bit address domain.	Yes	0-0h

9.4.251 ADDRESS LUT ACCESS DATA 1 REGISTER – OFFSET 920h

BIT	FUNCTION	TYPE	DESCRIPTION	EEPROM/ I2C-SMBUS	DEFAULT
31:0	LUT HData[31:0]	RW	Used to indicate the higher 32-bit destination base address in 64-bit address domain.	Yes	0000_0000h

9.4.252 REQ ID/DOMAIN LUT 0 – 15– OFFSET 924h to 960h

These 16 32-bit registers construct a Requester ID (RID) look-up table storing the RID of TLP issued from Local host, which connected to the CDLEP port directly. The table content can be either built by hardware automatically or written by software of management CPU. There are control signals defined in the 14th and 15th bits of [Device Configuration 2 Register at offset 50Ch of Port 0](#) to decide RID LUT build-up mechanism for CDLEP P0 and CDLEP P4 respectively.

Table 9-6: 16-Bit REQ ID/Domain LUT Entry 0-63 Register Locations

CFG_OFFSET	ID/DomainLUT Entry_n	CFG_OFFSET	ID/Domain LUT Entry_n
924h	0	944h	8
928h	1	948h	9
92Ch	2	94Ch	10
930h	3	950h	11
934h	4	954h	12
938h	5	958h	13
93Ch	6	95Ch	14
940h	7	960h	15

Table 9-7: 16-Bit REQ ID/Domain LUT Entry_n (n=0 through 15)

BIT	FUNCTION	TYPE	DESCRIPTION	EEPROM/ I2C-SMBUS	DEFAULT	
15:0	ReqID	RW	50Ch[14] / 50Ch[15] = 0	bit[2:0]: function number bit[7:3]: device number bit[15:8]: bus number	Yes	0000h
		RO	50Ch[14] / 50Ch[15] = 1			
30:16	Reserved	RsvdP	Not support.	No	0-0b	
31	Valid	RW	50Ch[14] / 50Ch[15] = 0	0b: the entry is not valid 1b: the entry is valid	Yes	0
		RO	50Ch[14] / 50Ch[15] = 1			

9.4.253 CAPTURED BUS ID for DOMAIN 0 to 1 – OFFSET 994h

BIT	FUNCTION	TYPE	DESCRIPTION	EEPROM/ I2C-SMBUS	DEFAULT
7:0	Dom. 0 Bus Number	RW	To set the captured bus number for Domain 0 as a destination Bus Number in RID translation.	Yes	00h

BIT	FUNCTION	TYPE	DESCRIPTION	EEPROM/ I2C-SMBUS	DEFAULT
15:8	Dom 1 Bus Number	RW	To set the captured bus number for Domain 1 as a destination Bus Number in RID translation.	Yes	00h
31:16	Reserved	RsvdP	Not Support.	No	00h

9.4.254 DOOR BELL IRQ SET REGISTER – OFFSET 9C4h

BIT	FUNCTION	TYPE	DESCRIPTION	EEPROM/ I2C-SMBUS	DEFAULT
31:0	Set IRQ	RW1S	Set link interface IRQ. If any of 32 bits is set and the corresponding bit in Door Bell IRQ register is not set, an interrupt will be issued in the link interface to local host. Writing“0” to this register does not take any effect. Interrupt can be in either INTx or MSI or MSI-X format depending on how system enabling which type of interrupts mechanism.	Yes	0000_0000h

9.4.255 DOOR BELL IRQ CLEAR REGISTER – OFFSET 9C8h

BIT	FUNCTION	TYPE	DESCRIPTION	EEPROM/ I2C-SMBUS	DEFAULT
31:0	Clear IRQ	RW1C	Clear link interface IRQ. Writing“1” to the bit whose corresponding bit is set in 9C4h will clear the bit. If INTx mechanism is chosen, an INTx deassert message will be generated. Writing“0” to this register does not take any effect.	Yes	0000_0000h

9.4.256 DOOR BELL IRQ MASK SET REGISTER – OFFSET 9CCh

BIT	FUNCTION	TYPE	DESCRIPTION	EEPROM/ I2C-SMBUS	DEFAULT
31:0	Set IRQ Mask	RW1S	Set link interface interrupt IRQ mask. Writing“1” to the bit whose corresponding bit in 9C4h for generating interrupt will be masked out. Writing“0” to this register does not take any effect.	Yes	FFFF_FFFFh

9.4.257 DOOR BELL IRQ MASK CLEAR REGISTER – OFFSET 9D0h

BIT	FUNCTION	TYPE	DESCRIPTION	EEPROM/ I2C-SMBUS	DEFAULT
31:0	Clear IRQ Mask	RW1C	Clear link interface interrupt IRQ mask. Writing “1” to the bit whose corresponding bit in 9C4h for generating interrupt will not be masked out. Writing“0” to this register does not take any effect.	Yes	FFFF_FFFFh

9.4.258 SCRATCHPAD 0 REGISTER – OFFSET 9E4h

BIT	FUNCTION	TYPE	DESCRIPTION	EEPROM/ I2C-SMBUS	DEFAULT
31:0	Scratchpad 0	RW	Scratchpad 0 register.	No/Yes	0000_0000h

9.4.259 SCRATCHPAD 1 REGISTER – OFFSET 9E8h

BIT	FUNCTION	TYPE	DESCRIPTION	EEPROM/ I2C-SMBUS	DEFAULT
31:0	Scratchpad 1	RW	Scratchpad 1 register.	No/Yes	0000_0000h

9.4.260 SCRATCHPAD 2 REGISTER – OFFSET 9ECh

BIT	FUNCTION	TYPE	DESCRIPTION	EEPROM/ I2C-SMBUS	DEFAULT
31:0	Scratchpad 2	RW	Scratchpad 2 register.	No/Yes	0000_0000h

9.4.261 SCRATCHPAD 3 REGISTER – OFFSET 9F0h

BIT	FUNCTION	TYPE	DESCRIPTION	EEPROM/ I2C-SMBUS	DEFAULT
31:0	Scratchpad 3	RW	Scratchpad 3 register.	Yes	0000_0000h

9.4.262 SCRATCHPAD 4 REGISTER – OFFSET 9F4h

BIT	FUNCTION	TYPE	DESCRIPTION	EEPROM/ I2C-SMBUS	DEFAULT
31:0	Scratchpad 4	RW	Scratchpad 4 register.	No/Yes	0000_0000h

9.4.263 SCRATCHPAD 5 REGISTER – OFFSET 9F8h

BIT	FUNCTION	TYPE	DESCRIPTION	EEPROM/ I2C-SMBUS	DEFAULT
31:0	Scratchpad 5	RW	Scratchpad 5 register.	No/Yes	0000_0000h

9.4.264 SCRATCHPAD 6 REGISTER – OFFSET 9FCh

BIT	FUNCTION	TYPE	DESCRIPTION	EEPROM/ I2C-SMBUS	DEFAULT
31:0	Scratchpad 6	RW	Scratchpad 6 register.	No/Yes	0000_0000h

9.4.265 SCRATCHPAD 7 REGISTER – OFFSET A00h

BIT	FUNCTION	TYPE	DESCRIPTION	EEPROM/ I2C-SMBUS	DEFAULT
31:0	Scratchpad 7	RW	Scratchpad 7 register.	No/Yes	0000_0000h

9.4.266 CDEP DATA 0 REGISTER – OFFSET A04h

BIT	FUNCTION	TYPE	DESCRIPTION	EEPROM/ I2C-SMBUS	DEFAULT
7:0	Bus Number	RO	Used to save the bus number for the CDEP.	No	00h
10:8	Total Tile Number	RO	Used to indicate the total tile number.	No	010b
11	Reserved	RsvdP	Not support.	No	0
15:12	Source Domain Number	RO	Used to save the source domain number.	No	0000b
17:16	CD Mode	RO	Used to save the status for Device Configuration CD Mode.	No	00b
18	CDEP Status	RO	Used to indicate CDEP status 1b: CDEP is enabled. 0b: CDEP is disabled	No	0
19	CDEP Type	RO	0b: CDELP 1b: CDVEP	No	0
31:20	Reserved	RsvdP	Not support.	No	0-0b

9.4.267 CDEP DATA 1 REGISTER – OFFSET A08h

BIT	FUNCTION	TYPE	DESCRIPTION	EEPROM/ I2C-SMBUS	DEFAULT
15:0	L_Host Request ID	RO	Used to indicate local host requester ID, which is captured during enumeration.	No	0000h
30:16	Reserved	RsvdP	Not support.	No	0000h
31	CDEP link enabled	RO	When set, the link between local host and CDLEP port is enabled. Once link is up, the configuration and memory commands will be sent to PRIMARY HOST via message queue or cross-domain translated transaction.	Yes	0

9.4.268 SQ/CQ POINTER CONTROL AND STATUS REGISTER – OFFSET A0Ch

BIT	FUNCTION	TYPE	DESCRIPTION	EEPROM/ I2C-SMBUS	DEFAULT
1:0	SQ Depth	RW	Notify CDLEP the depth of submission queue. The queue is allocated in the physical memory of PRIMARY HOST. 00: 8 entries 01: 16 entries 10: 32 entries 11: Not defined	No	00b
6:2	SQ Tail Index	RO	Indicate the current Tail pointer maintained by CDLEP For each transaction met the overlay range and converted into a message going out to PRIMARY HOST, the index will be increased by one and finally reset to zero after hitting to the SQ depth.	No	00000b
10:7	SQ Buffer Fullness Level	RO	Indicate the current fullness level in the SQ buffer located at CDLEP. For any new message that written into the SQ buffer temporarily, the level will be moved up by one. If the message read out from the SQ buffer, the level will be moved down by one. When the value equals to “8h”, it means the SQ buffer is full.	No	0000b
15:11	Reserved	RsvdP	Not support.	No	00h
19:16	MMIO_VAL FIFO Fullness Level	RO	Indicate the current fullness level for MMIO_VAL FIFO located at CDLEP. If the returned CQ message containing MMIO_VAL, it will be stored in the MMIO_VAL FIFO temporarily and the index will be moved up by one. If the message leaving the MMIO_VAL FIFO, the index will be moved down by one. When the value equals to “8h”, it means the MMIO_VAL FIFO is full.	No	0000b
31:20	Reserved	RsvdP	Not support.	No	000h

9.4.269 SQ TAIL BASE POINTER [31:0] REGISTER – OFFSET A10h

BIT	FUNCTION	TYPE	DESCRIPTION	EEPROM/ I2C-SMBUS	DEFAULT
31:0	SQ Tail Base Pointer_L	RW	Point to the tail base location of SQ, bit[31:0]. PRIMARY HOST has to program its SQ tail pointer register, which is the base address of the SQ maintained by PRIMARY HOST. So the switch can deliver the message to the correct location.	No	0000_0000h

9.4.270 SQ TAIL BASE POINTER [63:32] REGISTER – OFFSET A14h

BIT	FUNCTION	TYPE	DESCRIPTION	EEPROM/ I2C-SMBUS	DEFAULT
31:0	SQ Tail Base Pointer_H	RW	Point to the tail base location of SQ, bit[63:32]. PRIMARY HOST has to program its SQ tail pointer register, which	No	0000_0000h

BIT	FUNCTION	TYPE	DESCRIPTION	EEPROM/ I2C-SMBUS	DEFAULT
			is the base address of the SQ maintained by PRIMARY HOST. So the switch can deliver the message to the correct location.		

9.4.271 CQ HEADER LOCATION[31:0] REGISTER – OFFSET A18h

BIT	FUNCTION	TYPE	DESCRIPTION	EEPROM/ I2C-SMBUS	DEFAULT
31:0	CQ Header Pointer_L	RW	Point to location for CQ MMIO, bit[31:0]. PRIMARY HOST has to program its CQ header pointer register, which always points to the head of CQ maintained by the switch. This pointer must be in sync with one of the CD Port CQ Header locations that belong to the same local host domain.	No	0000_0000h

9.4.272 CQ HEADER LOCATION[63:32] REGISTER – OFFSET A1Ch

BIT	FUNCTION	TYPE	DESCRIPTION	EEPROM/ I2C-SMBUS	DEFAULT
31:0	CQ Header Pointer_H	RW	Point to location for CQ MMIO, bit[63:32]. PRIMARY HOST has to program its CQ header pointer register, which always points to the head of CQ maintained by the switch.	No	0000_0000h

9.4.273 UNCORRECTABLE FATAL ERROR LINK RESET REGISTER – OFFSET A28h

BIT	FUNCTION	TYPE	DESCRIPTION	EEPROM/ I2C-SMBUS	DEFAULT
3:0	Reserved	RsvdP	Not support.	No	0000b
4	Data Link Protocol Error	RW	When set, a fatal the Data Link Protocol Error event will reset the link.	Yes	0
5	Surprise Down Error	RW	When set, a fatal Surprise Down Error event will reset the link.	Yes	0
11:6	Reserved	RsvdP	Not support.	No	0-0b
12	Poisoned TLP	RW	When set, a fatal DP will reset the link.	Yes	0
13	Flow Control Protocol Error	RW	When set, a fatal Flow Control Protocol Error event will reset the link.	Yes	0
14	Completion Timeout	RW	When set, a fatal Completion Timeout event will reset the link.	Yes	0
15	Completer Abort	RW	When set, a fatal Completer Abort event will reset the link.	Yes	0
16	Unexpected Completion	RW	When set, a fatal Unexpected Completion event will reset the link.	Yes	0
17	Receiver Overflow	RW	When set, a fatal Receiver Overflow event will reset the link.	Yes	0
18	Malformed TLP	RW	When set, a fatal event of Malformed TLP will reset the link.	Yes	0
19	ECRC Error	RW	When set, a fatal event of ECRC Error will reset the link.	Yes	0
20	Unsupported Request Error	RW	When set, a fatal Unsupported Request even will reset the link.	Yes	0
21	ACS Violation	RW	When set, a fatal ACS even will reset the link.	Yes	0
22	Internal Error	RW	When set, a fatal Internal Error event will reset the link.	Yes	0
23	MC Blocked TLP	RW	When set, a fatal MC Blocked TLP event will reset the link.	Yes	0
24	AtomicOp Egress Blocked	RW	When set, a fatal AtomicOp Egress Blocked event will reset the link.	Yes	0
31:25	Reserved	RsvdP	Not support.	No	0

9.4.274 SYNC. CDVEP UNCORRECTABLE ERROR STATUS REGISTER – OFFSET A2Ch

BIT	FUNCTION	TYPE	DESCRIPTION	EEPROM/ I2C-SMBUS	DEFAULT
0	Training Error Status	RW	When set, indicates that the Training Error event has occurred. Retuen '0' when read.	Yes	0
3:1	Reserved	RsvdP	Not support.	No	000

BIT	FUNCTION	TYPE	DESCRIPTION	EEPROM/ I2C-SMBUS	DEFAULT
4	Data Link Protocol Error Status	RW	When set, indicates that the Data Link Protocol Error event has occurred. Retuen '0' when read.	Yes	0
5	Surprise Down Error Status	RW	When set, indicates that the Surprise Down Error event has occurred. Retuen '0' when read.	Yes	0
11:6	Reserved	RsvdP	Not support.	No	0-0b
12	Poisoned TLP Status	RW	When set, indicates that a Poisoned TLP has been received or generated. Retuen '0' when read.	Yes	0
13	Flow Control Protocol Error Status	RW	When set, indicates that the Flow Control Protocol Error event has occurred. Retuen '0' when read.	Yes	0
14	Completion Timeout Status	RW	When set, indicates that the Completion Timeout event has occurred. Retuen '0' when read.	Yes	0
15	Completer AbortStatus	RW	When set, indicates that the Completer Abort event has occurred. Retuen '0' when read.	Yes	0
16	Unexpected Completion Status	RW	When set, indicates that the Unexpected Completion event has occurred. Retuen '0' when read.	Yes	0
17	Receiver Overflow Status	RW	When set, indicates that the Receiver Overflow event has occurred. Retuen '0' when read.	Yes	0
18	Malformed TLP Status	RW	When set, indicates that a Malformed TLP has been received. Retuen '0' when read.	Yes	0
19	ECRC Error Status	RW	When set, indicates that an ECRC Error has been detected. Retuen '0' when read.	Yes	0
20	Unsupported Request Error Status	RW	When set, indicates that an Unsupported Request event has occurred. Retuen '0' when read.	Yes	0
21	ACS Violation Status	RW	When set, indicates that an ACS Violation event has occurred. Retuen '0' when read.	Yes	0
22	Internal Error Status	RW	When set, indicates that an Internal Error has occurred. Retuen '0' when read.	Yes	0
23	MC Blocked TLP Status	RW	When set, indicates that an MC Blocked TLP event has occurred. Retuen '0' when read.	Yes	0
24	AtomicOp Egress Blocked Status	RW	When set, indicates that an AtomicOp Egress Blocked event has occurred. Retuen '0' when read.	Yes	0
30:25	Reserved	RsvdP	Not support.	No	0000_000b
31	RW test bit	RW	RW test use.	Yes	0

9.4.275 Source ID LUT 0 – 7 – OFFSET A80h to A9Ch

These 8 32-bit registers construct a Source ID look-up table storing the ID pointed to the switch where the requester is located at. Also, there are two bits of each entry to indicate if the requester is an embedded DMA function. The table content is programmed by management CPU. These 8 entries identified by index numbers (0 ~ 7) represent the distinct Source ID and the associated DMA attributes.

Table 9-8 5-Bit Synthesized ID LUT Entry 0-15 Register Locations

CFG_OFFSET	STID LUT Entry_n
A80h	0
A84h	1
A88h	2
A8Ch	3
A90h	4
A94h	5
A98h	6
A9Ch	7

Table 9-9 5-Bit Source ID LUT Entry_n (n=0 through 7)

BIT	FUNCTION	TYPE	DESCRIPTION	EEPROM/ I2C-SMBUS	DEFAULT
0	DMA Requester	RW	Determine if the requester is an embedded DMA engine 0b: The requester is a bus master outside of the switch 1b: The requester is an DMA engine inside of the switch	Yes	0000h
1	DMA Function ID	RW	If the requester is a DMA engine (i.e. Bit-0 is set), it needs to decide what is the function ID of DMA engine in a source switch. There are two DMA functions in this switch.	Yes	0000h
4:2	Source ID	RW	Indicate the ID pointed to the switch at where the requester is located. The valid ID number is 0.	Yes	0000h
31:5	Reserved	RsvdP	Not support.	No	0-0b

9.5 CDVEP CONFIGURATION REGISTERS

When the port of the Switch is set to operate at cross-domain end point mode, it is represented by an Other Bridge that implements type 0 configuration space header. The following table details the allocation of the register fields of the PCI 2.3 compatible type 1 configuration space header.

31 – 24	23 – 16	15 – 8	7 – 0	BYTE OFFSET
Device ID		Vendor ID		00h
Primary Status		Command		04h
Class Code		Revision ID		08h
Reserved	Header Type	Primary Latency Timer	Cache Line Size	0Ch
BAR 0				10h
BAR 1				14h
BAR 2				18h
BAR 3				1Ch
BAR 4				20h
BAR 5				24h
Reserved				28h
SSID		SSVID		2Ch
Reserved				30h
Reserved		Capability Pointer to 40h		34h
Reserved				38h
Reserved		Interrupt Pin	Interrupt Line	3Ch
Power Management Capabilities		Next Item Pointer=48h	Capability ID=01h	40h
PM Data	PPB Support Extensions	Power Management Data		44h
Message Control		Next Item Pointer=68h	Capability ID=05h	48h
Message Address				4Ch
Message Upper Address				50h
Reserved		Message Data		54h
MSI Mask				58h
MSI Pending				5Ch
Reserved				60h – 64h
PCI Express Capabilities Register		Next Item Pointer=A4h	Capability ID=10h	68h
Device Capabilities				6Ch
Device Status		Device Control		70h
Link Capabilities				74h
Link Status		Link Control		78h
Slot Capabilities				7Ch
Slot Status		Slot Control		80h
Reserved				84h – 88h
Device Capabilities 2				8Ch
Device Status 2		Device Control 2		90h
Link Capabilities 2				94h
Link Status 2		Link Control 2		98h
Slot Capabilities 2				9Ch
Slot Status 2		Slot Control 2		A0h
Reserved		Next Item Pointer=B0h	SSID/SSVID Capability ID=0Dh	A4h
SSID		SSVID		A8h
Reserved				ACh
MSI-X Control		Next Item Pointer=C8h	MSI-X Capability ID=11h	B0h
MSI-X Table Offset / Table BIR				B4h
MSI-X PBA Offset / PBA BIR				B8h
Reserved				BCh – C4h
Length		Next Item Pointer=00h	Vendor Specific Capability ID=09h	C8h
Reserved				CCh – E0h
BAR 0-1 Configuration				E4h
BAR 2 Configuration for CDVEP				E8h
BAR 2-3 Configuration for CDVEP				ECh
BAR 4 Configuration for CDVEP				F0h
BAR 4-5 Configuration for CDVEP				F4h

31 – 24	23 – 16	15 – 8	7 – 0	BYTE OFFSET
Reserved				F8h - FCh

Other than the PCI 2.3 compatible configuration space header, the Switch also implements PCI express extended configuration space header, which includes advanced error reporting, virtual channel, and power budgeting capability registers. The following table details the allocation of the register fields of PCI express extended capability space header. The first extended capability always begins at offset 100h with a PCI Express Enhanced Capability header and the rest of capabilities are located at an offset greater than 0FFh relative to the beginning of PCI compatible configuration space.

31 – 24	23 – 16	15 – 8	7 – 0	BYTE OFFSET
Next Capability Offset=900h	Cap. Version	PCI Express Extended Capability ID=0003h		100h
Serial Number Lower DW				104h
Serial Number Upper DW				108h
Reserved				10Ch ~ 344h
Operation Mode (Port 0 Only)				348h
Reserved				34Ch ~ 4BCh
TL CSR 0				4C0h
Reserved				4C4h ~ 8FCh
Next Capability Offset=000h	Cap. Version	PCI Express Extended Capability ID=000Bh		900h
Vendor-Specific Length	Revision	Vendor-Specific ID		904h
BTR 2				908h
BTR 3				90Ch
BTR 4				910h
BTR 5				914h
Address LUT Access Address				918h
Address LUT Access Data 0				91Ch
Address LUT Address Data 1				920h
ID/Domain LUT 0 ~ 15				924h ~ 960h
Reserved				964h ~ 990h
Captured Bus ID for Domain 0 to 1				994h
Reserved				998h ~ 9C0h
Door Bell IRQ Set				9C4h
Door Bell IRQ Clear				9C8h
Door Bell IRQ Mask Set				9CCh
Door Bell IRQ Mask Clear				9D0h
Reserved				9D4h ~ 9E0h
Scratchpad 0 ~ 7				9E4h ~ A00h
CDEP Data 0				A04h
CDEP Data 1				A08h
Reserved				A0Ch ~ FFCh

9.5.1 VENDOR ID REGISTER – OFFSET 00h

BIT	FUNCTION	TYPE	DESCRIPTION	EEPROM/ I2C-SMBUS	DEFAULT
15:0	Vendor ID	RO	Identifies Pericom as the vendor of this device.	Yes	12D8h

9.5.2 DEVICE ID REGISTER – OFFSET 00h

BIT	FUNCTION	TYPE	DESCRIPTION	EEPROM/ I2C-SMBUS	DEFAULT
31:16	Device ID	RO	Identifies this device as the PI7C9X3G816.	Yes	C016h

9.5.3 COMMAND REGISTER – OFFSET 04h

BIT	FUNCTION	TYPE	DESCRIPTION	EEPROM/ I2C-SMBUS	DEFAULT
0	I/O Space Enable	RW	0b: Ignores I/O transactions on the primary interface 1b: Enables responses to I/O transactions on the primary interface	Yes	0

BIT	FUNCTION	TYPE	DESCRIPTION	EEPROM/ I2C-SMBUS	DEFAULT
1	Memory Space Enable	RW	0b: Ignores memory transactions on the primary interface 1b: Enables responses to memory transactions on the primary interface	Yes	0
2	Bus Master Enable	RW	0b: Does not initiate memory or I/O transactions on the upstream port and handles asan Unsupported Request (UR) to memory and I/O transactions on the downstream port. For Non-Posted Requests, a completion with UR completion status must be returned 1b: Enables the Switch Port to forward memory and I/O Read/Write transactions in the upstream direction	Yes	0
3	Special Cycle Enable	RsvdP	Not support.	No	0
4	Memory Write And Invalidate Enable	RsvdP	Not support.	No	0
5	VGA Palette Snoop Enable	RsvdP	Not support.	No	0
6	Parity Error Response Enable	RW	0b: Switch may ignore any parity errors that it detects and continue normal operation 1b: Switch must take its normal action when a parity error is detected	Yes	0
7	Wait Cycle Control	RsvdP	Not support.	No	0
8	SERR# enable	RW	0b: Disables the reporting of Non-fatal and Fatal errors detected by the Switch to the Root Complex 1b: Enables the Non-fatal and Fatal error reporting to Root Complex	Yes	0
9	Fast Back-to-Back Enable	RsvdP	Not support.	No	0
10	Interrupt Disable	RW	Controls the ability of a PCI Express device to generate INTx Interrupt Messages. In the Switch, this bit does not affect the forwarding of INTx messages from the downstream ports.	Yes	0
15:11	Reserved	RsvdP	Not support.	No	0000_0b

9.5.4 PRIMARY STATUS REGISTER – OFFSET 04h

BIT	FUNCTION	TYPE	DESCRIPTION	EEPROM/ I2C-SMBUS	DEFAULT
18:16	Reserved	RsvdP	Not support.	No	000b
19	Interrupt Status	RO	Indicates that an INTx Interrupt Message is pending internally to the device. In the Switch, the forwarding of INTx messages from the downstream device of the Switch port is not reflected in this bit. Must be hardwired to 0.	No	0
20	Capabilities List	RO	Set to 1b to enable support for the capability list (offset 34h is the pointer to the data structure).	Yes/No	1
21	66MHz Capable	RO	Does not apply to PCI Express. Must be hardwired to 0.	No	0
22	Reserved	RsvdP	Not support.	No	0
23	Fast Back-to-Back Capable	RsvdP	Not support.	No	0
24	Master Data Parity Error	RW1C	Set to 1b (by a requester) whenever a Parity error is detected or forwarded on the primary side of the port in a Switch. If the Parity Error Response Enable bit is cleared, this bit is never set.	No/Yes	0
26:25	DEVSEL# timing	RsvdP	Not support.	No	00b
27	Signaled Target Abort	RW1C	This bit is Set when the Secondary Side for Type 1 Configuration Space header Function (for Requests completed by the Type 1 header Function itself) completes a Posted or Non-Posted Request as a Completer Abort error.	No/Yes	0
28	Received Target Abort	RsvdP	Not support.	No	0
29	Received Master Abort	RsvdP	Not support.	No	0
30	Signaled System Error	RW1C	Set to 1b when the Switch sends an ERR_FATAL or ERR_NONFATAL Message, and the SERR Enable bit in the Command register is 1b.	No/Yes	0

BIT	FUNCTION	TYPE	DESCRIPTION	EEPROM/ I2C-SMBUS	DEFAULT
31	Detected Parity Error	RW1C	Set to 1b whenever the primary side of the port in a Switch receives a Poisoned TLP.	No/Yes	0

9.5.5 REVISION ID REGISTER – OFFSET 08h

BIT	FUNCTION	TYPE	DESCRIPTION	EEPROM/ I2C-SMBUS	DEFAULT
7:0	Revision	RO	Indicates revision number of device.	Yes	6h

9.5.6 CLASS REGISTER – OFFSET 08h

BIT	FUNCTION	TYPE	DESCRIPTION	EEPROM/ I2C-SMBUS	DEFAULT
15:8	Programming Interface	RO	Read as 00h to indicate no programming interfaces have been defined for PCI-to-PCI Bridges.	Yes/No	00h
23:16	Sub-Class Code	RO	Read as 04h to indicate device is an Other Bridge.	Yes/No	80h
31:24	Base Class Code	RO	Read as 06h to indicate device is a Bridge device.	Yes/No	06h

9.5.7 CACHE LINE REGISTER – OFFSET 0Ch

BIT	FUNCTION	TYPE	DESCRIPTION	EEPROM/ I2C-SMBUS	DEFAULT
7:0	Cache Line Size	RW	The cache line size register is set by the system firmware and the operating system cache line size. This field is implemented by PCI Express devices as a RW field for legacy compatibility, but it has no impact on any PCI Express device functionality.	Yes	00h

9.5.8 PRIMARY LATENCY TIMER REGISTER – OFFSET 0Ch

BIT	FUNCTION	TYPE	DESCRIPTION	EEPROM/ I2C-SMBUS	DEFAULT
15:8	Primary Latency Timer	RsvdP	Not support.	No	00h

9.5.9 HEADER TYPE REGISTER – OFFSET 0Ch

BIT	FUNCTION	TYPE	DESCRIPTION	EEPROM/ I2C-SMBUS	DEFAULT
22:16	Header Type	RO	To indicate that the register layout confirms to Type 0 Configuration Header for CDVEP.	No	00h
23	Multi-Function Device	RO	0b: Single function device 1b: Multiple functions device	No	0

9.5.10 BAR 0 REGISTER – OFFSET 10h

BIT	FUNCTION	TYPE	DESCRIPTION	EEPROM/ I2C-SMBUS	DEFAULT
0	Memory Space Indicator	RO	Reset to 0b to indicate Memory Base address.	No	0
2:1	64-bit Addressing	RO	00b: 32-bit addressing 10b: 64-bit addressing Others: Reserved	No	00b
3	Prefetchable	RO	0b: Non-prefetchable 1b: Prefetchable	No	0
18:4	Reserved	RsvdP	Not support.	No	0-0h
31:19	Base Address 0 [31:19]	RW	Use this Memory base address to map the packet switch registers.	Yes	0-0h

9.5.11 BAR 1 REGISTER – OFFSET 14h

BIT	FUNCTION	TYPE	DESCRIPTION	EEPROM/ I2C-SMBUS	DEFAULT
31:0	Reserved	RO	When the Base Address 0 register is not 64-bit addressing (offset 10h[2:1] is not 10b).	No	0000_0000h
	Base Address 1 [31:0]	RW	When the Base Address 0 register is 64-bit addressing. Base Address 1 is used to provide the upper 32 Address bits when offset 10h[2:1] is set to 10b.	Yes	

9.5.12 BAR 2 REGISTER – OFFSET 18h

BIT	FUNCTION	TYPE	DESCRIPTION	EEPROM/ I2C-SMBUS	DEFAULT
0	Memory Space Indicator	RO	Reset to 0b to indicate it is a Memory BAR.	No	0
2:1	Memory Map Type	RO	00b: support 32-bit Memory Space 10b: support 64-bit Memory Space When 64-bit memory space is supported, the assigned memory address has to be larger than 4GB.	No	00b
3	Prefetchable	RO	0b: Non-prefetchable 1b: Prefetchable	No	0
19:4	Reserved	RsvdP	Not support.	No	0-0h
31:20	Base Address 2 [31:20]	RW	Base Address 2.	Yes	000h

9.5.13 BAR 3 REGISTER – OFFSET 1Ch

BIT	FUNCTION	TYPE	DESCRIPTION	EEPROM/ I2C-SMBUS	DEFAULT
0	Memory Space Indicator	RO	When offset 18h[2:1] =00b, BAR 3 is used as an independent 32-bit BAR. Reset to 0b to indicate it is a Memory BAR.	No	0
	Base Address 2 [32]	RW	When offset 18h[2:1] =10b, BAR 3 is used as the upper 32 bits of 64-bit BAR 2/3.	Yes	0
2:1	Memory Map Type	RO	When offset 18h[2:1] =00b, BAR 3 is used as an independent 32-bit BAR. 00b: support 32-bit Memory Space 10b: support 64-bit Memory Space	No	00b
	Base Address 2 [34:33]	RW	When offset 18h[2:1] =10b, BAR 3 is used as the upper 32 bits of 64-bit BAR 2/3.	Yes	00b
3	Prefetchable	RO	When offset 18h[2:1] =00b, BAR 3 is used as an independent 32-bit BAR. 0b: Non-prefetchable 1b: Prefetchable	No	0
	Base Address 2 [35]	RW	When offset 18h[2:1] =10b, BAR 3 is used as the upper 32 bits of 64-bit BAR 2/3.	Yes	0
31:4	Base Address 3 [31:4]	RsvdP	When offset 18h[2:1] =00b, BAR 3 is used as an independent 32-bit BAR.	No	0000_000h
	Base Address 2 [63:36]	RW	When offset 18h[2:1] =10b, BAR 3 is used as the upper 32 bits of 64-bit BAR 2/3.	Yes	0000_000h

9.5.14 BAR 4 REGISTER – OFFSET 20h

BIT	FUNCTION	TYPE	DESCRIPTION	EEPROM/ I2C-SMBUS	DEFAULT
0	Memory Space Indicator	RO	Reset to 0b to indicate it is a Memory BAR.	No	0
2:1	Memory Map Type	RO	00b: support 32-bit Memory Space 10b: support 64-bit Memory Space When 64-bit memory space is supported, the assigned memory address has to be larger than 4GB.	No	00b
3	Prefetchable	RO	0b: Non-prefetchable 1b: Prefetchable	No	0
19:4	Reserved	RsvdP	Not support.	No	0-0h
31:20	Base Address 4 [31:20]	RW	Base Address 4.	Yes	000h

9.5.15 BAR 5 REGISTER – OFFSET 24h

BIT	FUNCTION	TYPE	DESCRIPTION	EEPROM/ I2C-SMBUS	DEFAULT
0	Memory Space Indicator	RO	When offset 20h[2:1] =00b, BAR 5 is used as an independent 32-bit BAR.	No	0
	Base Address 4 [32]	RW	When offset 20h[2:1] =10b, BAR 5 is used as the upper 32 bits of 64-bit BAR 4/5.	Yes	0
2:1	Memory Map Type	RO	When offset 20h[2:1] =00b, BAR 5 is used as an independent 32-bit BAR. 00b: support 32-bit Memory Space 10b: support 64-bit Memory Space	No	00b
	Base Address 4 [34:33]	RW	When offset 20h[2:1] =10b, BAR 5 is used as the upper 32 bits of 64-bit BAR 2/3.	Yes	00b
3	Prefetchable	RO	When offset 20h[2:1] =00b, BAR 5 is used as an independent 32-bit BAR. 0b: Non-prefetchable 1b: Prefetchable	No	0
	Base Address 4 [35]	RW	When offset 20h[2:1] =10b, BAR 5 is used as the upper 32 bits of 64-bit BAR 2/3.	Yes	0
31:4	Base Address 5 [31:4]	RsvdP	When offset 20h[2:1] =00b, BAR 5 is used as an independent 32-bit BAR.	No	0000_000h
	Base Address 4 [63:36]	RW	When offset 20h[2:1] =10b, BAR 5 is used as the upper 32 bits of 64-bit BAR 4/5.	Yes	0000_000h

9.5.16 SSVID REGISTER – OFFSET 2Ch

BIT	FUNCTION	TYPE	DESCRIPTION	EEPROM/ I2C-SMBUS	DEFAULT
15:0	SSVID	RO	Identifies the sub-system vendor id.	Yes	12D8h

9.5.17 SSID REGISTER – OFFSET 2Ch

BIT	FUNCTION	TYPE	DESCRIPTION	EEPROM/ I2C-SMBUS	DEFAULT
31:16	SSID	RO	Identifies the sub-system device id.	Yes	C016h

9.5.18 CAPABILITY POINTER REGISTER – OFFSET 34h

BIT	FUNCTION	TYPE	DESCRIPTION	EEPROM/ I2C-SMBUS	DEFAULT
7:0	Capability Pointer	RO	Point to first PCI capability structure.	Yes/No	40h

9.5.19 INTERRUPT LINE REGISTER – OFFSET 3Ch

BIT	FUNCTION	TYPE	DESCRIPTION	EEPROM/ I2C-SMBUS	DEFAULT
7:0	Interrupt Line	RW	The interrupt line register communicates interrupt line routing information.	Yes	00h

9.5.20 INTERRUPT PIN REGISTER – OFFSET 3Ch

BIT	FUNCTION	TYPE	DESCRIPTION	EEPROM/ I2C-SMBUS	DEFAULT
15:8	Interrupt Pin	RO	The Switch implements INTA virtual wire interrupt signalsto represent hot-plug events at downstream ports. 0b: disable INTA 1b: enable INTA	Yes/No	1h

9.5.21 POWER MANAGEMENT CAPABILITIES REGISTER – OFFSET 40h

BIT	FUNCTION	TYPE	DESCRIPTION	EEPROM/ I2C-SMBUS	DEFAULT
7:0	Enhanced Capabilities ID	RO	Read as 01h to indicate that this is power management capability register.	Yes/No	01h
15:8	Next Item Pointer	RO	Point to next PCI capability structure.	Yes/No	48h
18:16	Power Management Revision	RO	Read as 011b to indicate the device is compliant to Revision 1.2 of <i>PCI Power Management Interface Specifications</i> .	No	011b
19	PME# Clock	RO	Does not apply to PCI Express. Must be hardwired to 0.	No	0
20	Reserved	RsvdP	Not support.	No	0
21	Device specific Initialization	RO	Read as 0b to indicate Switch does not have device specific initialization requirements.	Yes/No	0
24:22	AUX Current	RO	To indicate aux current.	Yes/No	000b
25	D1 Power State Support	RO	Read as 0b to indicate Switch does Not support the D1 power management state.	Yes/No	0
26	D2 Power State Support	RO	Read as 0b to indicate Switch does Not support the D2 power management state.	Yes/No	0
31:27	PME# Support	RO	Read as 19h to indicate Switch supports the forwarding of PME# message in D0, D3 and D4 states.	Yes/No	00h

9.5.22 POWER MANAGEMENT DATA REGISTER – OFFSET 44h

BIT	FUNCTION	TYPE	DESCRIPTION	EEPROM/ I2C-SMBUS	DEFAULT
1:0	Power State	RW	Indicates the current power state of the Switch. Writing a value of D0 when the previous state was D3 cause a hot reset without asserting DWRST_L. 00b: D0 state 01b: D1 state 10b: D2 state 11b: D3 hot state	Yes	00b

BIT	FUNCTION	TYPE	DESCRIPTION	EEPROM/ I2C-SMBUS	DEFAULT
2	Reserved	RsvdP	Not support.	No	0
3	No_Soft_Reset	RO	When set, this bit indicates that device transitioning from D3hot to D0 does not perform an internal reset. When clear, an internal reset is performed when power state transits from D3hot to D0.	Yes/No	1
7:4	Reserved	RsvdP	Not support.	No	0h
8	PME# Enable	RW	When asserted, the Switch will generate the PME# message.	Yes/No	0
12:9	Data Select	RO	Select data registers.	No	0h
14:13	Data Scale	RO	Reset to 00b.	No	00b
15	PME Status	RW1C	Read as 0b as the PME# message is not implemented.	Yes/No	0

9.5.23 PPB SUPPORT EXTENSIONS REGISTER – OFFSET 44h

BIT	FUNCTION	TYPE	DESCRIPTION	EEPROM/ I2C-SMBUS	DEFAULT
21:16	Reserved	RsvdP	Not support.	No	00h
22	B2_B3 Support for D3HOT	RsvdP	Not support.	No	0
23	Bus Power / Clock Control Enable	RsvdP	Not support.	No	0

9.5.24 DATA REGISTER– OFFSET 44h

BIT	FUNCTION	TYPE	DESCRIPTION	EEPROM/ I2C-SMBUS	DEFAULT
31:24	Data Register	RO	Data Register.	Yes/No	00h

9.5.25 MSI CAPABILITIES REGISTER – OFFSET 48h

BIT	FUNCTION	TYPE	DESCRIPTION	EEPROM/ I2C-SMBUS	DEFAULT
7:0	Enhanced Capabilities ID	RO	Read as 05h to indicate that this is message signal interrupt capability register.	No	05h
15:8	Next Item Pointer	RO	Point to next PCI capability structure.	Yes/No	68h
16	MSI Enable	RW	0b: The function is prohibited from using MSI to request service 1b: The function is permitted to use MSI to request service and is prohibited from using its INTx # pin	Yes	0
19:17	Multiple Message Capable	RO	Indicate the number of requested vectors.	Yes	010b
22:20	Multiple Message Enable	RW	Software writes to this field to indicate the number of allocated vectors (equal to or less than the number of requested vectors.)	Yes	000b
23	64-bit address capable	RO	0b: The function is not capable of generating a 64-bit message address 1b: The function is capable of generating a 64-bit message address	Yes	1b
24	Pre-vector Masking Capable	RW	1b: the function supports MSI pre-vector masking. 0b: the function does Not support MSI pre-vector masking.	Yes	0b
31:25	Reserved	RO	Not support.	No	00h

9.5.26 MESSAGE ADDRESS REGISTER – OFFSET 4Ch

BIT	FUNCTION	TYPE	DESCRIPTION	EEPROM/ I2C-SMBUS	DEFAULT
1:0	Reserved	RsvdP	Not support.	No	00b
31:2	Message Address	RW	If the message enable bit is set, the contents of this register specify the DWORD aligned address for MSI memory write transaction.	Yes	0-0h

9.5.27 MESSAGE UPPER ADDRESS REGISTER – OFFSET 50h

BIT	FUNCTION	TYPE	DESCRIPTION	EEPROM/ I2C-SMBUS	DEFAULT
31:0	Message Upper	RW	This register is only effective if the device supports a 64-bit	Yes	0000_0000h

BIT	FUNCTION	TYPE	DESCRIPTION	EEPROM/ I2C-SMBUS	DEFAULT
	Address		message address is set.		

9.5.28 MESSAGE DATA REGISTER – OFFSET 54h

BIT	FUNCTION	TYPE	DESCRIPTION	EEPROM/ I2C-SMBUS	DEFAULT
15:0	Message Data	RW	Reset to 0.	Yes	0000h

9.5.29 MESSAGE MASK REGISTER – OFFSET 58h

BIT	FUNCTION	TYPE	DESCRIPTION	EEPROM/ I2C-SMBUS	DEFAULT
0	MSI Mask for Hot Plug	RW	MSI mask for Hot Plug interrupts.	Yes	0
1	MSI Mask for DPC	RW	MSI mask for DPC interrupts.	Yes	0
2	MSI Mask for DMA and GPIO	RW	MSI mask for DMAGPIO interrupts.	Yes	0
3	MSI Mask for CDEP	RW	MSI mask for CDEP interrupts.	Yes	0
31:4	Reserved	RsvdP	Not support.	No	0000_000h

9.5.30 MESSAGE PENDING REGISTER – OFFSET 5Ch

BIT	FUNCTION	TYPE	DESCRIPTION	EEPROM/ I2C-SMBUS	DEFAULT
0	MSI Pending for Hot Plug Interrupts	RO	MSI pending status for Hot Plug interrupts.	No	0
1	MSI Pending for DPC Interrupts	RO	MSI pending status for DPC interrupts.	No	0
2	MSI Pending for GPIO Interrupts	RO	MSI pending status for GPIO interrupts.	No	0
3	MSI Pending for CDEP Interrupts	RO	MSI pending status for CDEP interrupts.	No	0
31:4	Reserved	RsvdP	Not support.	No	0000_000h

9.5.31 PCI EXPRESS CAPABILITIES REGISTER – OFFSET 68h

BIT	FUNCTION	TYPE	DESCRIPTION	EEPROM/ I2C-SMBUS	DEFAULT
7:0	Enhanced Capabilities ID	RO	Read as 10h to indicate that this is PCI express capability register.	No	10h
15:8	Next Item Pointer	RO	Point to next PCI capability structure.	Yes/No	A4h
19:16	Capability Version	RO	Read as 2h to indicate the device is compliant to Revision .2.0 of <i>PCI Express Base Specifications</i> .	Yes/No	2h
23:20	Device/Port Type	RO	Indicates the type of PCI Express logical device.	Yes/No	0h
24	Slot Implemented	RO	When set, indicates that the PCIe Link associated with this Port is connected to a slot. This field is valid for downstream ports of the Switch.	Yes/No	0
29:25	Interrupt Message Number	RO	Read as 0. No MSI messages are generated in the transparent mode.	No	00_000b
31:30	Reserved	RsvdP	Not support.	No	00b

9.5.32 DEVICE CAPABILITIES REGISTER – OFFSET 6Ch

BIT	FUNCTION	TYPE	DESCRIPTION	EEPROM/ I2C-SMBUS	DEFAULT
2:0	Max_Payload_Size Supported	RO	Indicates the maximum payload size that the device can support for TLPs. Each port of the Switch supports 512 bytes max payload size.	Yes/No	010b

BIT	FUNCTION	TYPE	DESCRIPTION	EEPROM/ I2C-SMBUS	DEFAULT
4:3	Phantom Functions Supported	RO	Indicates the support for use of unclaimed function numbers as Phantom functions. Read as 00b, since the Switch does not act as a requester.	No	00b
5	Extended Tag Field Supported	RO	Indicates the maximum supported size of Tag field as a Requester. Read as 0, since the Switch does not act as a requester.	No	1
8:6	Endpoint L0s Acceptable Latency	RO	Acceptable total latency that an Endpoint can withstand due to the transition from L0s state to the L0 state. For Switch, the ASPM software would not check this value.	No	111b
11:9	Endpoint L1 Acceptable Latency	RO	Acceptable total latency that an Endpoint can withstand due to the transition from L1 state to the L0 state. For Switch, the ASPM software would not check this value.	No	111b
14:12	Reserved	RsvdP	Not support.	No	000b
15	Role_Based Error Reporting	RO	When set, indicates that the device implements the functionality originally defined in the Error Reporting ECN.	Yes/No	1
17:16	Reserved	RsvdP	Not support.	No	00b
25:18	Captured Slot Power Limit Value	RO	In combination with the Slot Power Limit Scale value, specifies the upper limit on power supplied by slot. This value is set by the Set_Slot_Power_Limit message or hardwired to 00h.	No	00h
27:26	Captured Slot Power Limit Scale	RO	Specifies the scale used for the Slot Power Limit Value. This value is set by the Set_Slot_Power_Limit message or hardwired to 00b.	No	00b
31:28	Reserved	RsvdP	Not support.	No	0h

9.5.33 DEVICE CONTROL REGISTER – OFFSET 70h

BIT	FUNCTION	TYPE	DESCRIPTION	EEPROM/ I2C-SMBUS	DEFAULT
0	Correctable Error Reporting Enable	RW	0b: Disable Correctable Error Reporting 1b: Enable Correctable Error Reporting	Yes	0
1	Non-Fatal Error Reporting Enable	RW	0b: Disable Non-Fatal Error Reporting 1b: Enable Non-Fatal Error Reporting	Yes	0
2	Fatal Error Reporting Enable	RW	0b: Disable Fatal Error Reporting 1b: Enable Fatal Error Reporting	Yes	0
3	Unsupported Request Reporting Enable	RW	0b: Disable Unsupported Request Reporting 1b: Enable Unsupported Request Reporting	Yes	0
4	Enable Relaxed Ordering	RO	When set, it permits the device to set the Relaxed Ordering bit in the attribute field of transaction. Since the Switch can not either act as a requester or alter the content of packet it forwards, this bit always returns '0' when read.	No	0
7:5	Max_Payload_Size	RW	This field sets maximum TLP payload size for the device. Permissible values that can be programmed are indicated by the Max_Payload_Size Supported in the Device Capabilities register. Any value exceeding the Max_Payload_Size Supported written to this register results into clamping to the Max_Payload_Size Supported value.	Yes	000b
8	Extended Tag Field Enable	RW	When set, this bit enables a function to use an 8-bit Tag field as a requester. If the bit is clear, the function is restricted to a 5-bit Tag field.	Yes	0
9	Reserved	RsvdP	Not support.	No	0
10	Auxiliary (AUX) Power PM Enable	RO	When set, indicates that a device is enabled to draw AUX power independent of PME AUX power.	No	0
11	Enable No Snoop	RO	When set, it permits to set the No Snoop bit in the attribute field of transaction. Since the Switch can not either act as a requester or alter the content of packet it forwards, this bit always returns '0' when read.	No	0
14:12	Max_Read_Request_Size	RO	This field sets the maximum Read Request size for the device as a Requester. Since the Switch does not generate read request by itself, these bits are hardwired to 0.	No	000b
15	Reserved	RsvdP	Not support.	No	0

9.5.34 DEVICE STATUS REGISTER – OFFSET 70h

BIT	FUNCTION	TYPE	DESCRIPTION	EEPROM/ I2C-SMBUS	DEFAULT
16	Correctable Error Detected	RW1C	Asserted when correctable error is detected. Errors are logged in this register regardless of whether error reporting is enabled or not in the Device Control register.	Yes	0
17	Non-Fatal Error Detected	RW1C	Asserted when non-fatal error is detected. Errors are logged in this register regardless of whether error reporting is enabled or not in the Device Control register.	Yes	0
18	Fatal Error Detected	RW1C	Asserted when fatal error is detected. Errors are logged in this register regardless of whether error reporting is enabled or not in the Device Control register.	Yes	0
19	Unsupported Request Detected	RW1C	Asserted when unsupported request is detected. Errors are logged in this register regardless of whether error reporting is enabled or not in the Device Control register.	Yes	0
20	AUX Power Detected	RO	Asserted when the AUX power is detected by the Switch	No	0
21	Transactions Pending	RO	Each port of Switch does not issue Non-posted Requests on its own behalf, so this bit is hardwired to 0b.	No	0
31:22	Reserved	RsvdP	Not support.	No	0-0h

9.5.35 LINK CAPABILITIES REGISTER – OFFSET 74h

BIT	FUNCTION	TYPE	DESCRIPTION	EEPROM/ I2C-SMBUS	DEFAULT
3:0	Maximum Link Speed	RO	Indicates the maximum speed of the Express link is 8Gb/s, 5Gb/s and 2.5 Gb/s. 0001b: 2.5 Gb/s 0010b: 5.0 Gb/s 0011b: 8.0 Gb/s Others: Reserved	Yes/No	2h
9:4	Maximum Link Width	RO	Indicates the maximum width of the given PCIe Link. Valid widths are x1, x2 or x4 which are set by PORTCFG[2:0] strap pins. Please refer to Table 5-1 00_0001b: x1 lane width 00_0010b: x2 lane width 00_0100b: x4 lane width 00_1000b: x8 lane width	Yes	Set by PORTCFG [2:0]
11:10	Active State Power Management (ASPM) Support	RO	Indicates the level of ASPM supported on the given PCIe Link. Each port of Switch supports L0s and L1 entry.	Yes/No	10b
14:12	L0s Exit Latency	RO	Indicates the L0s exit latency for the given PCIe Link. The length of time this port requires to complete transition from L0s to L0 is in the range of 256ns to less than 512ns.	Yes/No	011b
17:15	L1 Exit Latency	RO	Indicates the L1 exit latency for the given PCIe Link. The length of time this port requires to complete transition from L1 to L0 is less than 1us.	Yes/No	000b
18	Clock Power Management	RsvdP	Not support.	No	0
19	Surprise Down Capability Enable	RsvdP	Not support.	No	0
20	Data Link Layer Active Reporting Capable	RsvdP	Not support.	No	0
21	Link BW Notify Cap.	RsvdP	Not support.	No	0
22	ASPM Optionality Compliance	RsvdP	Not support.	No	0
23	Reserved	RsvdP	Not support.	No	0
31:24	Port Number	RO	Indicates the PCIe Port Number for the given PCIe Link.	Yes/No	80h

9.5.36 LINK CONTROL REGISTER – OFFSET 78h

BIT	FUNCTION	TYPE	DESCRIPTION	EEPROM/ I2C-SMBUS	DEFAULT
1:0	Active State Power Management (ASPM) Control	RW	00b: ASPM is Disabled 01b: L0s Entry Enabled 10b: L1 Entry Enabled 11b: L0s and L1 Entry Enabled Note that the receiver must be capable of entering L0s even when the field is disabled	Yes	00b
2	Reserved	RsvdP	Not support.	No	0
3	Read Completion Boundary (RCB)	RsvdP	Not support.	No	0
4	Link Disable	RsvdP	Not support.	No	0
5	Retrain Link	RsvdP	Not support.	No	0
6	Common Clock Configuration	RW	0b: The components at both ends of a link are operating with synchronous reference clock 1b: The components at both ends of a link are operating with a distributed common reference clock	Yes	0
7	Extended Synch	RW	When set, it transmits 4096 FTS ordered sets in the L0s state for entering L0 state and transmits 1024 TS1 ordered sets in the L1 state for entering L0 state.	Yes	0
8	Enable Clock Power Management	RsvdP	Not support.	No	0
9	HW Autonomous Width Disable	RsvdP	Not support.	No	0
10	Link Bandwidth Management Interrupt Enable	RsvdP	Not support.	No	0
11	Link Autonomous Bandwidth Interrupt Enable	RsvdP	Not support.	No	0
15:12	Reserved	RsvdP	Not support.	No	0h

9.5.37 LINK STATUS REGISTER – OFFSET 78h

BIT	FUNCTION	TYPE	DESCRIPTION	EEPROM/ I2C-SMBUS	DEFAULT
19:16	Link Speed	RO	Indicate the negotiated speed of the Express link. 0001b: 2.5 Gb/s 0010b: 5.0 Gb/s 0011b: 8.0 Gb/s	No	0h
25:20	Negotiated Link Width	RO	Indicates the negotiated width of the given PCIe link. 00_0001b: x1 lane width 00_0010b: x2 lane width 00_0100b: x4 lane width 00_1000b: x8 lane width	No	Set by PORTCFG [2:0]
26	Training Error	RO	When set, indicates a Link training error occurred. This bit is cleared by hardware upon successful training of the link to the L0 link state.	No	0
27	Link Training	RO	When set, indicates the link training is in progress. Hardware clears this bit once link training is complete.	No	0
28	Slot Clock Configuration	RO	0b: the Switch uses an independent clock irrespective of the presence of a reference on the connector 1b: the Switch uses the same reference clock that the platform provides on the connector	Yes/No	0
29	Data Link Layer Link Active	RO	Indicates the status of the Data Link Control and Management State Machine. 1b: indicate the DL_Active state 0b: otherwise	No	0
30	Link Bandwidth Management Status	RsvdP	Not support.	No	0

BIT	FUNCTION	TYPE	DESCRIPTION	EEPROM/ I2C-SMBUS	DEFAULT
31	Link Autonomous Bandwidth Status	RsvdP	Not support.	No	0

9.5.38 SLOT CAPABILITIES REGISTER – OFFSET 7Ch

BIT	FUNCTION	TYPE	DESCRIPTION	EEPROM/ I2C-SMBUS	DEFAULT
31:0	Reserved	RsvdP	Not support.	No	0000_0000h

9.5.39 SLOT CONTROL REGISTER – OFFSET 80h

BIT	FUNCTION	TYPE	DESCRIPTION	EEPROM/ I2C-SMBUS	DEFAULT
15:0	Reserved	RsvdP	Not support.	No	0000h

9.5.40 SLOT STATUS REGISTER – OFFSET 80h

BIT	FUNCTION	TYPE	DESCRIPTION	EEPROM/ I2C-SMBUS	DEFAULT
31:16	Reserved	RsvdP	Not support.	No	0-0h

9.5.41 DEVICE CAPABILITIES REGISTER 2 – OFFSET 8Ch

BIT	FUNCTION	TYPE	DESCRIPTION	EEPROM/ I2C-SMBUS	DEFAULT
31:0	Reserved	RsvdP	Not support.	No	0000_0000h

9.5.42 DEVICE CONTROL REGISTER 2 – OFFSET 90h

BIT	FUNCTION	TYPE	DESCRIPTION	EEPROM/ I2C-SMBUS	DEFAULT
15:0	Reserved	RsvdP	Not support.	No	0000h

9.5.43 DEVICE STATUS REGISTER 2 – OFFSET 90h

BIT	FUNCTION	TYPE	DESCRIPTION	EEPROM/ I2C-SMBUS	DEFAULT
31:16	Reserved	RsvdP	Not support.	No	0000h

9.5.44 LINK CAPABILITIES REGISTER 2 – OFFSET 94h

BIT	FUNCTION	TYPE	DESCRIPTION	EEPROM/ I2C-SMBUS	DEFAULT
0	Reserved	RsvdP	Not support.	No	0
7:1	Supported Link Speeds Vector	RO	This field indicates the supported Link speed of the associated Port. bit[0]... 2.5 GT/s bit[1]... 5.0 GT/s bit[2]... 8.0 GT/s bit[6:3]... RsvdP	No	0-0b
8	Crosslink Supported	RO	0b: Crosslink is Not supported 1b: Crosslink is supported	No	0
31:9	Reserved	RsvdP	Not support.	No	0-0b

9.5.45 LINK CONTROL REGISTER 2 – OFFSET 98h

BIT	FUNCTION	TYPE	DESCRIPTION	EEPROM/ I2C-SMBUS	DEFAULT
3:0	Target Link Speed	RW	0001b: 2.5GT/s link speed is supported 0010b: 5.0GT/s link speed is supported 0011b: 8.0GT/s link speed is supported Others: reserved.	Yes	2h
4	Enter Compliance	RW	1b: enter compliance	Yes	0
5	HW_AutoSpeed_Dis	RW	When set, this bit disables hardware from changing the link speed for device-specific reasons other than attempting to correct unreliable link operation by reducing link speed.	Yes	0
6	Select_Deemp	RO	Valid for downstream ports only. 0b: Select -3.5db de-emphasis 1b: Select -6.0 db de-emphasis	Yes/No	0
9:7	Tran_Margin	RW	This field controls the value of the non-deemphasized voltage level at the transmitter pins. Valid for upstream port only.	Yes	000b
10	Enter Modify Compliance	RW	When set, the device transmits modified compliance pattern if the LTSSM enters Polling.Compliance substate. Valid for upstream port only.	Yes	0
11	Compliance SOS	RW	When set, the LTSSM is required to send SKP Ordered Sets between sequences when sending the Compliance Pattern or Modified Compliance Pattern.	Yes	0
15:12	Compliance Preset/De-emphasis	RW	This field is intended for debug and compliance testing purpose.	Yes	000b

9.5.46 LINK STATUS REGISTER 2 – OFFSET 98h

BIT	FUNCTION	TYPE	DESCRIPTION	EEPROM/ I2C-SMBUS	DEFAULT
16	Current De-emphasis level	RO	1b: -3.5dB 0b: -6 dB	No	1
17	Equalization Complete	RO	When set to 1b, this bit indicates that the Transmitter Equalization procedure has completed.	No	0
18	Equalization Phase 1 Successful	RO	When set to 1b, this bit indicates that Phase 1 of Transmitter Equalization procedure has successfully completed.	No	0
19	Equalization Phase 2 Successful	RO	When set to 1b, this bit indicates that Phase 2 of Transmitter Equalization procedure has successfully completed.	No	0
20	Equalization Phase 3 Successful	RO	When set to 1b, this bit indicates that Phase 3 of Transmitter Equalization procedure has successfully completed.	No	0
21	Link Equalization Request	RW1C	This bit is set by hardware to request the Link equalization process to be performed on the link.	Yes	0
27:22	Reserved	RsvdP	Not support.	No	0-0b
30:28	Downstream Component Presence	RO	This field indicates the presence and DRS status for the Downstream Component. 000b: Link Down – Presence Not Determined 001b: Link Down – Component Not Present 010b: Link Down – Component Present 011b: Reserved 100b: Link Up – Component Present 101b: Link Up – Component Present and DRS Received 110b: Reserved 111b: Reserved	No	000b
31	DRS Message Received	RW1C	This bit must be set whenever the Port receives a DRS message.	Yes	0

9.5.47 SLOT CAPABILITIES REGISTER 2 – OFFSET 9Ch

BIT	FUNCTION	TYPE	DESCRIPTION	EEPROM/ I2C-SMBUS	DEFAULT
31:0	Reserved	RsvdP	Not support.	No	0000_0000h

9.5.48 SLOT CONTROL REGISTER 2 – OFFSET A0h

BIT	FUNCTION	TYPE	DESCRIPTION	EEPROM/ I2C-SMBUS	DEFAULT
15:0	Reserved	RsvdP	Not support.	No	0000_0000h

9.5.49 SLOT STATUS REGISTER 2 – OFFSET A0h

BIT	FUNCTION	TYPE	DESCRIPTION	EEPROM/ I2C-SMBUS	DEFAULT
31:16	Reserved	RsvdP	Not support.	No	0000_0000h

9.5.50 SSID/SSVID CAPATILITIES REGISTER – OFFSET A4h

BIT	FUNCTION	TYPE	DESCRIPTION	EEPROM/ I2C-SMBUS	DEFAULT
7:0	SSID/SSVID Capabilities ID	RO	Read as 0Dh to indicate that this is SSID/SSVID capability register.	Yes/No	0Dh
15:8	Next Item Pointer	RO	Point to next PCI capability structure.	Yes/No	B0h
31:16	Reserved	RsvdP	Not support.	No	0000h

9.5.51 SUBSYSTEM VENDOR ID REGISTER – OFFSET A8h

BIT	FUNCTION	TYPE	DESCRIPTION	EEPROM/ I2C-SMBUS	DEFAULT
15:0	SSVID	RO	It indicates the sub-system vendor id.	Yes	12D8h

9.5.52 SUBSYSTEM ID REGISTER – OFFSET A8h

BIT	FUNCTION	TYPE	DESCRIPTION	EEPROM/ I2C-SMBUS	DEFAULT
31:16	SSID	RO	It indicates the sub-system device id.	Yes	C016h

9.5.53 MSI-X CAPATILITIES REGISTER – OFFSET B0h

BIT	FUNCTION	TYPE	DESCRIPTION	EEPROM/ I2C-SMBUS	DEFAULT
7:0	MSI-X Capabilities ID	RO	Read as 11h to indicate that this is MSI-X capability register.	No	11h
15:8	Next Item Pointer	RO	Indicates next capability pointer.	Yes	C8h
26:16	Table Size	RO	System software reads this field to determine the MSI-X Table Size N, which is encoded as N-1.	No	000h
29:27	Reserved	RsvdP	Not support.	No	000b
30	Function Mask	RW	If set, all of the vectors associated with the function are masked, regardless of their per-vector mask bit values. If clear, each vector's mask bit determines whether the vector is masked or not.	Yes	0
31	MSI-X Enable	RW	If set and the MSI Enable bit in the MSI Message Control register is clear, the function is permitted to use MSI-X to request service and is prohibited from using INTx interrupts (if implemented). If clear, the function is prohibited from using MSI-X to request service.	Yes	0

9.5.54 MSI-X TABLE OFFSET / TABLE BIR REGSITER – OFFSET B4h

BIT	FUNCTION	TYPE	DESCRIPTION	EEPROM/ I2C-SMBUS	DEFAULT
2:0	Table BIR	RO	Read as 000b to indicate Base Address 0 register (offset 10h in Configuration Space) is used to map the function MSI-X Table into Memory space.	Yes	000b
31:3	Table Offset	RO	Used as an offset from the address contained by one of the function's Base Address registers to point to the base of the MSI-X Table.	Yes	0000_FE00h

9.5.55 MSI-X PBA OFFSET / PBA BIR REGISTER – OFFSET B8h

BIT	FUNCTION	TYPE	DESCRIPTION	EEPROM/ I2C-SMBUS	DEFAULT
2:0	PBA BIR	RO	Read as 000b to indicate Base Address 0 register (offset 10h in Configuration Space) is used to map the function MSI-X PBA into Memory space.	Yes	000b
31:3	PBA Offset	RO	Used as an offset from the address contained by one of the function's Base Address registers to point to the base of the MSI-X PBA.	Yes	0000_FE10h

9.5.56 VENDOR SPECIFIC CAPABILITY REGISTER – OFFSET C8h

BIT	FUNCTION	TYPE	DESCRIPTION	EEPROM/ I2C-SMBUS	DEFAULT
7:0	Enhanced Capabilities ID	RO	Read as 09h to indicate that these are vendor specific capability registers.	No	09h
15:8	Next Item Pointer	RO	Read as 00h. No other ECP registers.	No	00h
31:16	Length Information	RO	The length field provides the information for number of bytes in the capability structure.	No	0038h

9.5.57 BAR 0-1 CONFIGURATION REGISTER – OFFSET E4h

BIT	FUNCTION	TYPE	DESCRIPTION	EEPROM/ I2C-SMBUS	DEFAULT
1:0	BAR 0 Type	RW	00b: disable 01b: reserved 10b: BAR0 is implemented as a 32-bit Memory BAR. 11b: BAR0/1 is implemented as a 64-bit Memory BAR.	Yes	10b
2	BAR0 Prefetch	RW	0b: Non-Prefetchable 1b: Prefetchable	Yes	0b
31:3	Reserved	RsvdP	Not support.	No	0000_0000h

9.5.58 BAR 2 CONFIGURATION REGISTER – OFFSET E8h

BIT	FUNCTION	TYPE	DESCRIPTION	EEPROM/ I2C-SMBUS	DEFAULT
0	Type Selector	RsvdP	Not supported.	No	0
2:1	BAR2 Type	RW	00b: BAR2 is implemented as a 32 bit Memory BAR 10b: BAR2/3 is implemented as a 64-bit Memory BAR	Yes	00b
3	Prefetchable	RW	0b: Non Prefetchable 1b: Prefetchable	Yes	0
4	LUT/BTR Selection	RW	0b: BAR2/3 is used for Address Look-up Translation. 1b: BAR2/3 is used for Direct Address Translation.	Yes	0
8:5	Domain ID	RW	The valid number is from 0 to 11.	Yes	0000b
19:9	Reserved	RsvdP	Not supported.	No	0-0b

BIT	FUNCTION	TYPE	DESCRIPTION	EEPROM/ I2C-SMBUS	DEFAULT
30:20	BAR2 Size	RW	To specify BAR2 size. 0b: Corresponding BAR2 bits are RO bits that always return 0 1b: Corresponding BAR2 bits are RW bits It implies the minimum window size is 1MB and minimum page size is 8KB, which is windows size divided by 128 (number of LUT entries).	Yes	7FFh
31	BAR 2 Enable	RW	bit[2:1]=00b	Yes	1
	BAR 2 Size	RW	bit[2:1]=10b		
			0b: Disable BAR2 1b: Enable BAR2		
			Includes with bit[30:20] when this BAR is used as a 64-bit BAR (bit[2:1]=10b).		

9.5.59 BAR 2-3 CONFIGURATION REGISTER – OFFSET ECh

BIT	FUNCTION	TYPE	DESCRIPTION	EEPROM/ I2C-SMBUS	DEFAULT	
0	Type Selector	RsvdP	E8h[2:1]=00b	Not support.	No	0
		RW	E8h[2:1]=10b	BAR2/3 are used as a 64-bit BAR, bit[31:0] are used as the upper 32-bits.	Yes	0
2:1	BAR3 Type	RO	E8h[2:1]=00b	00b: BAR3 is implemented as 32 bit Memory BAR.	Yes	00b
		RW	E8h[2:1]=10b	BAR2/3 are used as a 64-bit BAR, bit[31:0] are used as the upper 32-bits.	Yes	00b
3	Prefetchable	RW	E8h[2:1]=00b	0b: Non Prefetchable 1b: Prefetchable	Yes	0
		RW	E8h[2:1]=10b	BAR2/3 are used as a 64-bit BAR, bit[31:0] are used as the upper 32-bits.		
4	Reserved	RsvdP	E8h[2:1]=00b	Not support.	No	0
		RW	E8h[2:1]=10b	BAR2/3 are used as a 64-bit BAR, bit[31:0] are used as the upper 32-bits.	Yes	0
8:5	Domain ID	RW	E8h[2:1]=00b	The valid number is from 0 to 11.	Yes	0000b
		RW	E8h[2:1]=10b	BAR2/3 are used as a 64-bit BAR, bit[31:0] are used as the upper 32-bits.		
19:9	Reserved	RsvdP	E8h[2:1]=00b	Not support.	No	0-0b
		RW	E8h[2:1]=10b	BAR2/3 are used as a 64-bit BAR, bit[31:0] are used as the upper 32-bits.	Yes	0-0b
30:20	BAR3 Size	RW	To specify BAR3 size. 0b: Corresponding BAR3 bits are RO bits that always return 0 1b: Corresponding BAR3 bits are RW bits	Yes	000h	
31	BAR 3 Enable	RW	E8h[2:1]=00b	Yes	0	
	64-Bit BAR	RW	E8h[2:1]=10b			
			0b: Disable BAR3 1b: Enable BAR3			
			0b: BAR2/3 is disabled, all BAR2/3 bits read 0. 1b: BAR2/3 is enabled as a 64-bit BAR.			

9.5.60 BAR 4 CONFIGURATION REGISTER – OFFSET F0h

BIT	FUNCTION	TYPE	DESCRIPTION	EEPROM/ I2C-SMBUS	DEFAULT
0	Type Selector	RsvdP	Not supported.	No	0
2:1	BAR4 Type	RW	00b: BAR4 is implemented as a 32 bit Memory BAR 10b: BAR4/5 is implemented as a 64-bit Memory BAR	Yes	00b
3	Prefetchable	RW	0b: Non Prefetchable 1b: Prefetchable	Yes	0
4	LUT/BTR Selection	RW	0b: BAR4/5 is used for Address Look-up Translation. 1b: BAR4/5 is used for Direct Address Translation.	Yes	0
8:5	Domain ID	RW	The valid number is from 0 to 11.	Yes	0000b
19:9	Reserved	RsvdP	Not supported.	No	0-0b

BIT	FUNCTION	TYPE	DESCRIPTION	EEPROM/ I2C-SMBUS	DEFAULT
30:20	BAR 4 Size	RW	To specify BAR4 size. 0b: Corresponding BAR4 bits are RO bits that always return 0 1b: Corresponding BAR4 bits are RW bits	Yes	7Fh
31	BAR 4 Enable	RW	bit[2:1]=00b 0b: Disable BAR4 1b: Enable BAR4	Yes	1
	BAR 4 Size	RW	bit[2:1]=10b Includes with bit[30:20] when this BAR is used as a 64-bit BAR (bit[2:1]=10b).		

9.5.61 BAR 4-5 CONFIGURATION REGISTER – OFFSET F4h

BIT	FUNCTION	TYPE	DESCRIPTION	EEPROM/ I2C-SMBUS	DEFAULT
0	Type Selector	RsvdP	F0h[2:1]=00b Not support.	No	0
		RW	F0h[2:1]=10b BAR4/5 are used as a 64-bit BAR, bit[31:0]are used as the upper 32-bits.	Yes	0
2:1	BAR 5 Type	RO	F0h[2:1]=00b 00b: BAR5 is implemented as 32 bit Memory BAR.	Yes	00b
		RW	F0h[2:1]=10b BAR4/5 are used as a 64-bit BAR, bit[31:0]are used as the upper 32-bits.	Yes	00b
3	Prefetchable	RW	F0h[2:1]=00b 0b: Non Prefetchable 1b: Prefetchable	Yes	0
		RW	F0h[2:1]=10b BAR4/5 are used as a 64-bit BAR, bit[31:0]are used as the upper 32-bits.		
4	Reserved	RsvdP	F0h[2:1]=00b Not support.	No	0
		RW	F0h[2:1]=10b BAR4/5 are used as a 64-bit BAR, bit[31:0]are used as the upper 32-bits.	Yes	0
8:5	Domain ID	RW	F0h[2:1]=00b The valid number is from 0 to 11.	Yes	0000b
		RW	F0h[2:1]=10b BAR4/5 are used as a 64-bit BAR, bit[31:0]are used as the upper 32-bits.		
19:9	Reserved	RsvdP	F0h[2:1]=00b Not support.	No	0-0b
		RW	F0h[2:1]=10b BAR4/5 are used as a 64-bit BAR, bit[31:0]are used as the upper 32-bits.	Yes	0-0b
30:20	BAR 5 Size	RW	To specify BAR5 size. 0b: Corresponding BAR 5 bits are RO bits that always return 0 1b: Corresponding BAR5 bits are RW bits	Yes	000h
31	BAR 5 Enable	RW	F0h[2:1]=00b 0b: Disable BAR5 1b: Enable BAR5	Yes	0
	64-Bit BAR	RW	F0h[2:1]=10b 0b: BAR4/5 is disabled, all BAR4/5 bits read 0. 1b: BAR4/5 is enabled as a 64-bit BAR.		

9.5.62 DEVICE SERIAL NUMBER ENHANCED CAPABILITY HEADER REGISTER – OFFSET 100h

BIT	FUNCTION	TYPE	DESCRIPTION	EEPROM/ I2C-SMBUS	DEFAULT
15:0	Extended Capabilities ID	RO	Read as 0003h to indicate that this is PCI express extended capability register for device serial number.	No	0003h
19:16	Capability Version	RO	Must be 1h for this version.	No	1h
31:20	Next Capability Offset	RO	Point to next PCI extended capability structure.	Yes/No	900h

9.5.63 DEVICE SERIAL NUMBER LOWER DW REGISTER – OFFSET 104h

BIT	FUNCTION	TYPE	DESCRIPTION	EEPROM/ I2C-SMBUS	DEFAULT
31:0	Device serial number	RO	Reset to 0000_12D8h.	Yes/No	0000_12D8h

BIT	FUNCTION	TYPE	DESCRIPTION	EEPROM/ I2C-SMBUS	DEFAULT
	1 st DW				

9.5.64 DEVICE SERIAL NUMBER HIGHTER DW REGISTER – OFFSET 108h

BIT	FUNCTION	TYPE	DESCRIPTION	EEPROM/ I2C-SMBUS	DEFAULT
31:0	Device serial number 2 nd DW	RO	Reset to 0816_4896h.	Yes/No	0816_4896h

9.5.65 OPERATION MODE REGISTER – OFFSET 348h (Port 0 Only)

BIT	FUNCTION	TYPE	DESCRIPTION	EEPROM/ I2C-SMBUS	DEFAULT
2:0	Reserved	RsvdP	Not support.	No	000b
5:3	pkgssel	RO	Package Bonding option.	No	001b
8:6	portcfg	RO	Port/lane configuration settins. 001b: 2 x4 ports 010b: 1 x4, 2 x2 ports 011b: 4 x2 ports 100b: 1 x4, 4 x1 ports 101b: 8 x1 ports Others: Reserved	No	Set by PORTCFG [2:0]
10:9	chipmode	RO	Chip operation mode selection. 00b: Normal mode 01b: iddq/mbist mode 10b: AC JTAG mode 11b: phy_mode	No	Set by CHIPMODE [1:0]
12:11	Reserved	RsvdP	Not support.	No	00b
13	ckmode	RO	Reference clock modes. 0b: base mode 1b: CDEP separate reference mode	No	Set by CKMODE
14	dma_mode	RO	0b: disable DMA 1b: enable DMA	No	0
20:15	upport_sel	RO	Upstream port selection.	No	0000_00b
21	CDEP_mode	RO	0b: disable CDEP 1b: enable CDEP	No	0
22	scan_tm	RO	0b: normal mode 1b: scan mode	No	0
23	hotplug_pin_en	RO	0b: GPIO[31:0] are GPIO pins 1b: GPIO[31:0] are used as hot plug pins	No	Set by HOT_PLUG EN_L
24	surprise_hp_en	RO	0b: disable surprise hot-plug 1b: enable surprise hot-plug	No	Set by SURPRISE_HP
25	ioe_40bit_en	RO	0b: support 16 bit IOE 1b: support 40 bit IOE	No	0
26	clkbuf_pd	RO	0b: clock buffer is in normal mode 1b: clock buffer is in power down mode	No	Set by CLKBUFPD_L
27	pm_l1_1_en	RO	0b: GPIO[15:8] are GPIO pins 1b: GPIO[15:8] are used as CLKREQ_L[7:0]	No	Set by PM_L11_EN_L
30:28	i2c/smaddr_out	RO	Indicate I2C/SMBUS address.	No	Set by I2C_ADDRESS [2:0]
31	Reserved	RsvdP	Not Support.	No	1

9.5.66 TL CSR 0 REGISTER – OFFSET 4C0h

BIT	FUNCTION	TYPE	DESCRIPTION	EEPROM/ I2C-SMBUS	DEFAULT
7:0	Reserved	RsvdP	Not support.	No	00h
8	p_inta_slot	RW	Internal used only.	Yes	0
9	p_inta_gpio	RW	Internal used only.	Yes	0
10	p_inta_ntl	RW	Internal used only.	Yes	0
31:11	Reserved	RsvdP	Not support.	No	0-0h

9.5.67 VENDOR SPECIFIC CAPABILITIES REGISTER – OFFSET 900h

BIT	FUNCTION	TYPE	DESCRIPTION	EEPROM/ I2C-SMBUS	DEFAULT
15:0	Extended Capabilities ID	RO	Read as 000Bh to indicate that this is PCI express extended capability register for vendor specific.	No	000Bh
19:16	Capability Version	RO	Read as 1h.	No	1h
31:20	Next Capability Offset	RO	Read as 000h. No other ECP registers.	No	000h

9.5.68 VENDOR SPECIFIC HEADER REGISTER – OFFSET 904h

BIT	FUNCTION	TYPE	DESCRIPTION	EEPROM/ I2C-SMBUS	DEFAULT
15:0	VSEC ID	RO	This field is a vendor-defined ID number that indicates the nature and format of the VSEC structure.	No	0001h
19:16	VSEC Rev	RO	This field is a vendor-defined version number that indicates the version of the VSEC structure.	No	0h
31:20	VSEC Length	RO	This field indicates the number of bytes in the entire VSEC structure.	No	280h

9.5.69 BTR 2 REGISTER – OFFSET 908h

BIT	FUNCTION	TYPE	DESCRIPTION	EEPROM/ I2C-SMBUS	DEFAULT
0	3DW Address Space	RW	0b: the translated TLP header is in 4DW format 1b: the translated TLP header is in 3DW format	Yes	0
19:1	Reserved	RsvdP	Not support.	No	0_0000h
31:20	Memory BAR 2 Address Translation	RW	This is the destination base address for Direct Address Translation. Valid when BAR 2 is enabled (offset E8h[31]=1). Please note that the source base address used in DAT is defined in BAR 2 located at offset 18h	Yes	000h

9.5.70 BTR 3 REGISTER – OFFSET 90Ch

BIT	FUNCTION	TYPE	DESCRIPTION	EEPROM/ I2C-SMBUS	DEFAULT
19:0	Reserved	RsvdP	E8h[2:1]=00b Not support	No	0_0000h
		RW	E8h[2:1]=10b BAR2/3 are used as a 64-bit source BAR, the bit[31:0] are used as the upper 32-bits of destination base address.	Yes	
31:20	Memory BAR 3 Address Translation	RW	E8h[2:1]=00b Valid when BAR 3 is enabled (offset ECh[31]=1).	Yes	000h
		RW	E8h[2:1]=10b BAR2/3 are used as a 64-bit source BAR, the bit[31:0] are used as the upper 32-bits of destination base address.		

9.5.71 BTR 4 REGISTER – OFFSET 910h

BIT	FUNCTION	TYPE	DESCRIPTION	EEPROM/ I2C-SMBUS	DEFAULT
0	3DW Address Space	RW	0b: the translated TLP header is in 4DW format 1b: the translated TLP header is in 3DW format	Yes	0
19:1	Reserved	RsvdP	Not support.	No	0_0000h
31:20	Memory BAR 4 Address Translation	RW	This is the destination base address for Direct Address Translation. Valid when BAR 4 is enabled (offset F0h[31]=1). Please note that the source base address used in DAT is defined in BAR 4 located at offset 20h	Yes	000h

9.5.72 BTR 5 REGISTER – OFFSET 914h

BIT	FUNCTION	TYPE	DESCRIPTION	EEPROM/ I2C-SMBUS	DEFAULT
19:0	Reserved	RsvdP	F0h[2:1]=00b Not support.	No	0_0000h
		RW	F0h[2:1]=10b BAR4/5 are used as a 64-bit source BAR, the bit[31:0] are used as the upper 32-bits of destination base address.	Yes	
31:20	Memory BAR 5 Address Translation	RW	F0h[2:1]=00b Valid when BAR 5 is enabled (offset F4h[31]=1).	Yes	000h
			F0h[2:1]=10b BAR4/5 are used as a 64-bit source BAR, the bit[31:0] are used as the upper 32-bits of destination base address.		

9.5.73 ADDRESS LUT ACCESS ADDRESS REGISTER – OFFSET 918h

BIT	FUNCTION	TYPE	DESCRIPTION	EEPROM/ I2C-SMBUS	DEFAULT
6:0	Index	RW	Used to indicate the LUT Entry number.	Yes	000_0000b
7	Reserved	RsvdP	Not support.	No	0
8	Command	WO	0b: Read command 1b: Write command Return '0' when read always.	Yes	0
31:9	Reserved	RsvdP	Not support.	No	0-0h

9.5.74 ADDRESS LUT ACCESS DATA 0 REGISTER – OFFSET 91Ch

BIT	FUNCTION	TYPE	DESCRIPTION	EEPROM/ I2C-SMBUS	DEFAULT
0	3DW Address Space	RW	0b: the translated TLP header is in 4DW format 1b: the translated TLP header is in 3DW format	Yes	0
4:1	Domain Number	RW	Used to indicate the domain number.	Yes	0000b
12:5	Reserved	RsvdP	Not support.	No	0-0b
31:13	LUT Data[31:13]	RW	Used to indicate LUT Data[31:13].	Yes	0000_0h

9.5.75 ADDRESS LUT ACCESS DATA 1 REGISTER – OFFSET 920h

BIT	FUNCTION	TYPE	DESCRIPTION	EEPROM/ I2C-SMBUS	DEFAULT
31:0	LUT HData[31:0]	RW	Used to indicate the higher 32-bit destination base address in 64-bit address domain.	Yes	0000_0000h

9.5.76 ID/DOMAIN LUT 0 – 15– OFFSET 924h to 960h

These 16 32-bit registers construct a Requester ID (RID) look-up table storing the RID of TLP issued from Primary Host, which connected to the upstream port directly. The table content can be either built by hardware automatically or written by software of management CPU. There are control signals defined in the 14th and 15th bits of [Device Configuration 2 Register at offset 50Ch of Port 0](#) to decide RID LUT build-up mechanism for CDVEP P0 and CDLEP P4 respectively.

Table 9-10: 16-Bit ID/Domain LUT Entry 0-15 Register Locations

CFG_OFFSET	ID/DomainLUT Entry_n	CFG_OFFSET	ID/Domain LUT Entry_n
924h	0	944h	8
928h	1	948h	9
92Ch	2	94Ch	10
930h	3	950h	11
934h	4	954h	12
938h	5	958h	13
93Ch	6	95Ch	14
940h	7	960h	15

Table 9-11: 16-Bit ID/Domain LUT Entry_n (n=0 through 15)

BIT	FUNCTION	TYPE	DESCRIPTION	EEPROM/ I2C-SMBUS	DEFAULT
15:0	ReqID	RW	bit[2:0]: function number bit[7:3]: device number bit[15:8]: bus number	Yes	0000h
30:16	Reserved	RsvdP	Not support.	No	0-0b
31	Valid	RW	0b: the entry is not valid 1b: the entry is valid	Yes	0

9.5.77 CAPTURED BUS ID FOR DOMAIN 0 to 1 – OFFSTE 994h

BIT	FUNCTION	TYPE	DESCRIPTION	EEPROM/ I2C-SMBUS	DEFAULT
7:0	Dom. 0 Bus Number	RW	To set the captured bus number for Domain 0 as a destination Bus Number in RID translation.	Yes	00h
15:8	Dom. 1 Bus Number	RW	To set the captured bus number for Domain 1 as a destination Bus Number in RID translation.	Yes	00h
31:16	Reserved	RsvdP	Not support.	No	00h

9.5.78 DOOR BELL IRQ SET REGISTER – OFFSET 9C4h

BIT	FUNCTION	TYPE	DESCRIPTION	EEPROM/ I2C-SMBUS	DEFAULT
31:0	Set IRQ	RW	Set virtual interface IRQ to control the state of the virtual interface doorbell interrupt request. Reading returns the status of the bits. Writing 0 to a bit in the register has no effect. Writing 1 to a bit in the register sets the corresponding interrupt request.	Yes	0000_0000h

9.5.79 DOOR BELL IRQ CLEAR REGISTER – OFFSET 9C8h

BIT	FUNCTION	TYPE	DESCRIPTION	EEPROM/ I2C-SMBUS	DEFAULT
31:0	Clear IRQ	RW1C	Clear virtual interface IRQ to control the state of the virtual interface doorbell interrupt request. Reading returns the status of the bits. Writing 0 to a bit in the register has no effect. Writing 1 to a bit in the register clears the corresponding interrupt request.	Yes	0000_0000h

9.5.80 DOOR BELL IRQ MASK SET REGISTER – OFFSET 9CCh

BIT	FUNCTION	TYPE	DESCRIPTION	EEPROM/ I2C-SMBUS	DEFAULT
31:0	Set IRQ Mask	RW	Set virtual interface interrupt IRQ mask. Reading returns the state of the interrupt mask bits. Writing 0 to a bit in the register has no effect. Writing 1 to a bit in the register clears the corresponding interrupt mask bit.	Yes	FFFF_FFFFh

9.5.81 DOOR BELL IRQ MASK CLEAR REGISTER – OFFSET 9D0h

BIT	FUNCTION	TYPE	DESCRIPTION	EEPROM/ I2C-SMBUS	DEFAULT
31:0	Clear IRQ Mask	RW1C	Clear virtual interface interrupt IRQ mask to control the state of the virtual interface interrupt request bits. Reading returns the state of the interrupt mask bits. Writing 0 to a bit in the register has no effect. Writing 1 to a bit in the register clears the corresponding interrupt mask bit.	Yes	FFFF_FFFFh

9.5.82 SCRATCHPAD 0 REGISTER – OFFSET 9E4h

BIT	FUNCTION	TYPE	DESCRIPTION	EEPROM/ I2C-SMBUS	DEFAULT
31:0	Scratchpad 0	RW	Scratchpad 0 register.	No/Yes	0000_0000h

9.5.83 SCRATCHPAD 1 REGISTER – OFFSET 9E8h

BIT	FUNCTION	TYPE	DESCRIPTION	EEPROM/ I2C-SMBUS	DEFAULT
31:0	Scratchpad 1	RW	Scratchpad 1 register.	No/Yes	0000_0000h

9.5.84 SCRATCHPAD 2 REGISTER – OFFSET 9ECh

BIT	FUNCTION	TYPE	DESCRIPTION	EEPROM/ I2C-SMBUS	DEFAULT
31:0	Scratchpad 2	RW	Scratchpad 2 register.	No/Yes	0000_0000h

9.5.85 SCRATCHPAD 3 REGISTER – OFFSET 9F0h

BIT	FUNCTION	TYPE	DESCRIPTION	EEPROM/ I2C-SMBUS	DEFAULT
31:0	Scratchpad 3	RW	Scratchpad 3 register.	No/Yes	0000_0000h

9.5.86 SCRATCHPAD 4 REGISTER – OFFSET 9F4h

BIT	FUNCTION	TYPE	DESCRIPTION	EEPROM/ I2C-SMBUS	DEFAULT
31:0	Scratchpad 4	RW	Scratchpad 4 register.	No/Yes	0000_0000h

9.5.87 SCRATCHPAD 5 REGISTER – OFFSET 9F8h

BIT	FUNCTION	TYPE	DESCRIPTION	EEPROM/ I2C-SMBUS	DEFAULT
31:0	Scratchpad 5	RW	Scratchpad 5 register.	No/Yes	0000_0000h

9.5.88 SCRATCHPAD 6 REGISTER – OFFSET 9FCh

BIT	FUNCTION	TYPE	DESCRIPTION	EEPROM/ I2C-SMBUS	DEFAULT
31:0	Scratchpad 6	RW	Scratchpad 6 register.	No/Yes	0000_0000h

9.5.89 SCRATCHPAD 7 REGISTER – OFFSET A00h

BIT	FUNCTION	TYPE	DESCRIPTION	EEPROM/ I2C-SMBUS	DEFAULT
31:0	Scratchpad 7	RW	Scratchpad 7 register.	No/Yes	0000_0000h

9.5.90 CDEP DATA 0 REGISTER – OFFSET A04h

BIT	FUNCTION	TYPE	DESCRIPTION	EEPROM/ I2C-SMBUS	DEFAULT
7:0	Bus Number	RO	Used to save the bus number for the CDEP.	No	00h
10:8	Total Tile Number	RO	Used to indicate the total tile number.	No	010b
11	Reserved	RsvdP	Not support.	No	0
15:12	Source Domain Number	RO	Used to save the source domain number.	No	0000b
17:16	CD Mode	RO	Used to save the status for Device Configuration CD Mode.	No	00b
18	CDEP Status	RO	Used to indicate CDEP status 1b: CDEP is enabled. 0b: CDEP is disabled	No	1
19	CDEP Type	RO	0b: CDEP is not enabled. 1b: CDVEP	No	1
31:20	Reserved	RsvdP	Not support.	No	0-0b

9.5.91 CDEP DATA1 REGISTER – OFFSET A08h

BIT	FUNCTION	TYPE	DESCRIPTION	EEPROM/ I2C-SMBUS	DEFAULT
15:0	L_Host Request ID	RO	Used to indicate local host requester ID, which is captured during enumeration.	No	0000h
31:16	Reserved	RsvdP	Not support.	No	0000h

9.6 DMA ENGINE CONFIGURATION REGISTERS (FUNC1 or FUNC2)

The switch contains two DMA engines (function number 1 or 2). The following table details the allocation of the register fields of the PCI 2.3 compatible type 0 configuration space header.

31 – 24	23 – 16	15 – 8	7 – 0	BYTE OFFSET
Device ID		Vendor ID		00h
Primary Status		Command		04h
Class Code		Revision ID		08h
Reserved	Header Type	Primary Latency Timer	Cache Line Size	0Ch
BAR 0				10h
BAR 1				14h
Reserved				14h - 28h
SSID		SSVID		2Ch
Reserved				30h
Reserved			Capability Pointer to 40h	34h
Reserved				38h
Reserved		Interrupt Pin	Interrupt Line	3Ch
Power Management Capabilities		Next Item Pointer=48h	Capability ID=01h	40h
PM Data	PPB Support Extensions	Power Management Data		44h
Message Control		Next Item Pointer=68h	Capability ID=05h	48h
Message Address				4Ch
Message Upper Address				50h
Reserved		Message Data		54h
MSI Mask				58h
MSI Pending				5Ch
Reserved				60h – 64h
PCI Express Capabilities Register		Next Item Pointer=A4h	Capability ID=10h	68h
Device Capabilities				6Ch
Device Status		Device Control		70h
Link Capabilities				74h
Link Status		Link Control		78h
Reserved				7Ch - 88h
Device Capabilities 2				8Ch
Device Status 2		Device Control 2		90h
Link Capabilities 2				94h
Link Status 2		Link Control 2		98h
Reserved				9Ch– A0h
Reserved		Next Item Pointer=00h	SSID/SSVID Capability ID=0Dh	A4h
SSID		SSVID		A8h
Reserved				ACh - FCh

Other than the PCI 2.3 compatible configuration space header, the Switch also implements PCI express extended configuration space header, which includes advanced error reporting, virtual channel, and power budgeting capability registers. The following table details the allocation of the register fields of PCI express extended capability space header. The first extended capability always begins at offset 100h with a PCI Express Enhanced Capability header and the rest of capabilities are located at an offset greater than 0FFh relative to the beginning of PCI compatible configuration space.

31 – 24	23 – 16	15 - 8	7 – 0	BYTE OFFSET
Next Capability Offset=000h		PCI Express Extended Capability ID=0001h		100h
Cap. Version				
Uncorrectable Error Status Register				104h
Uncorrectable Error Mask Register				108h
Uncorrectable Error Severity Register				10Ch
Correctable Error Status Register				110h
Correctable Error Mask Register				114h
Advanced Error Capabilities and Control Register				118h
Header Log Register 0				11Ch
Header Log Register 1				120h

31 – 24	23 – 16	15 – 8	7 – 0	BYTE OFFSET
Header Log Register 2				124h
Header Log Register 3				128h
Reserved				12Ch - FFCh

9.6.1 VENDOR ID REGISTER – OFFSET 00h

BIT	FUNCTION	TYPE	DESCRIPTION	EEPROM/ I2C-SMBUS	DEFAULT
15:0	Vendor ID	RO	Identifies Pericom as the vendor of this device.	No	12D8h

9.6.2 DEVICE ID REGISTER – OFFSET 00h

BIT	FUNCTION	TYPE	DESCRIPTION	EEPROM/ I2C-SMBUS	DEFAULT
31:16	Device ID	RO	Identifies this device as the PI7C9X3G816.	No	C016h

9.6.3 COMMAND REGISTER – OFFSET 04h

BIT	FUNCTION	TYPE	DESCRIPTION	EEPROM/ I2C-SMBUS	DEFAULT
0	I/O Space Enable	RW	0b: Ignores I/O transactions on the primary interface 1b: Enables responses to I/O transactions on the primary interface	No	0
1	Memory Space Enable	RW	0b: Ignores memory transactions on the primary interface 1b: Enables responses to memory transactions on the primary interface	No	0
2	Bus Master Enable	RW	0b: Does not initiate memory or I/O transactions on the upstream port and handles as an Unsupported Request (UR) to memory and I/O transactions on the downstream port. For Non-Posted Requests, a completion with UR completion status must be returned 1b: Enables the Switch Port to forward memory and I/O Read/Write transactions in the upstream direction	No	0
3	Special Cycle Enable	RsvdP	Not support.	No	0
4	Memory Write And Invalidate Enable	RsvdP	Not support.	No	0
5	VGA Palette Snoop Enable	RsvdP	Not support.	No	0
6	Parity Error Response Enable	RW	0b: Switch may ignore any parity errors that it detects and continue normal operation 1b: Switch must take its normal action when a parity error is detected	No	0
7	Wait Cycle Control	RsvdP	Not support.	No	0
8	SERR# enable	RW	0b: Disables the reporting of Non-fatal and Fatal errors detected by the Switch to the Root Complex 1b: Enables the Non-fatal and Fatal error reporting to Root Complex	No	0
9	Fast Back-to-Back Enable	RsvdP	Not support.	No	0
10	Interrupt Disable	RW	0b: Enable to generate INTx Interrupt Messages 1b: Disable to generate INTx Interrupt Messages	No	0
15:11	Reserved	RsvdP	Not support.	No	0000_0b

9.6.4 PRIMARY STATUS REGISTER – OFFSET 04h

BIT	FUNCTION	TYPE	DESCRIPTION	EEPROM/ I2C-SMBUS	DEFAULT
18:16	Reserved	RsvdP	Not support.	No	000b
19	Interrupt Status	RO	Indicates that an INTx Interrupt Message is pending internally to the device. In the Switch, the forwarding of INTx messages from the downstream device of the Switch port is not reflected in this bit. Must be hardwired to 0.	No	0

BIT	FUNCTION	TYPE	DESCRIPTION	EEPROM/ I2C-SMBUS	DEFAULT
20	Capabilities List	RO	Set to 1b to enable support for the capability list (offset 34h is the pointer to the data structure).	No	1
21	66MHz Capable	RsvdP	Not support	No	0
22	Reserved	RsvdP	Not support.	No	0
23	Fast Back-to-Back Capable	RsvdP	Not support.	No	0
24	Master Data Parity Error	RW1C	Set to 1b (by a requester) whenever a Parity error is detected or forwarded on the primary side of the port in a Switch. If the Parity Error Response Enable bit is cleared, this bit is never set.	No	0
26:25	DEVSEL# timing	RsvdP	Not support.	No	00b
27	Signaled Target Abort	RW1C	This bit is Set when the Secondary Side for Type 1 Configuration Space header Function (for Requests completed by the Type 1 header Function itself) completes a Posted or Non-Posted Request as a Completer Abort error.	No	0
28	Received Target Abort	RsvdP	Not support.	No	0
29	Received Master Abort	RsvdP	Not support.	No	0
30	Signaled System Error	RW1C	Set to 1b when the Switch sends an ERR_FATAL or ERR_NONFATAL Message, and the SERR Enable bit in the Command register is 1b.	No	0
31	Detected Parity Error	RW1C	Set to 1b whenever the primary side of the port in a Switch receives a Poisoned TLP.	No	0

9.6.5 REVISION ID REGISTER – OFFSET 08h

BIT	FUNCTION	TYPE	DESCRIPTION	EEPROM/ I2C-SMBUS	DEFAULT
7:0	Revision	RO	Indicates revision number of device.	No	07h

9.6.6 CLASS CODE REGISTER – OFFSET 08h

BIT	FUNCTION	TYPE	DESCRIPTION	EEPROM/ I2C-SMBUS	DEFAULT
15:8	Programming Interface	RO	Read as 00h.	No	00h
23:16	Sub-Class Code	RO	Read as 80h.	No	80h
31:24	Base Class Code	RO	Read as 08h to indicate device is other system peripheral.	No	08h

9.6.7 CACHE LINE REGISTER – OFFSET 0Ch

BIT	FUNCTION	TYPE	DESCRIPTION	EEPROM/ I2C-SMBUS	DEFAULT
7:0	Cache Line Size	RW	The cache line size register is set by the system firmware and the operating system cache line size. This field is implemented by PCI Express devices as a RW field for legacy compatibility, but it has no impact on any PCI Express device functionality.	No	00h

9.6.8 PRIMARY LATENCY TIMER REGISTER – OFFSET 0Ch

BIT	FUNCTION	TYPE	DESCRIPTION	EEPROM/ I2C-SMBUS	DEFAULT
15:8	Primary Latency Timer	RsvdP	Not support.	No	00h

9.6.9 HEADER TYPE REGISTER – OFFSET 0Ch

BIT	FUNCTION	TYPE	DESCRIPTION	EEPROM/ I2C-SMBUS	DEFAULT
23:16	Header Type	RO	Read as 80h to indicate that the register layout conforms to Type 0 Configuration Header for the other device.	No	80h

9.6.10 BAR 0 REGISTER – OFFSET 10h

BIT	FUNCTION	TYPE	DESCRIPTION	EEPROM/ I2C-SMBUS	DEFAULT
0	Memory Space Indicator	RO	When set '0', it indicates Memory Base address.	No	0
2:1	64-bit Addressing	RO	00b: 32-bit addressing 10b: 64-bit addressing Others: Reserved	No	10b
3	Prefetchable	RO	0b: Non-prefetchable 1b: Prefetchable	No	0
11:4	Reserved	RsvdP	Not support.	No	0-0h
31:12	Base Address 0 [31:12]	RW	Use this Memory base address to map DMA engine registers.	No	0-0h

9.6.11 BAR 1 REGISTER – OFFSET 14h

BIT	FUNCTION	TYPE	DESCRIPTION	EEPROM/ I2C-SMBUS	DEFAULT
31:0	Reserved	RO	When the Base Address 0 register is not 64-bit addressing (offset 10h[2:1] is not 10b).	No	0000_0000h
	Base Address 1 [63:32]	RW	When the Base Address 0 register is 64-bit addressing. Base Address 1 is used to provide the upper 32 Address bits when offset 10h[2:1] is set to 10b.	No	

9.6.12 SUBSYSTEM VENDOR ID REGISTER – OFFSET 2Ch

BIT	FUNCTION	TYPE	DESCRIPTION	EEPROM/ I2C-SMBUS	DEFAULT
15:0	SSVID	RO	It indicates the sub-system vendor id.	No	12D8h

9.6.13 SUBSYSTEM ID REGISTER – OFFSET 2Ch

BIT	FUNCTION	TYPE	DESCRIPTION	EEPROM/ I2C-SMBUS	DEFAULT
31:16	SSID	RO	It indicates the sub-system device id.	No	C016h

9.6.14 CAPABILITY POINTER REGISTER – OFFSET 34h

BIT	FUNCTION	TYPE	DESCRIPTION	EEPROM/ I2C-SMBUS	DEFAULT
7:0	Capability Pointer	RO	Point to first PCI capability structure.	No	40h

9.6.15 INTERRUPT LINE REGISTER – OFFSET 3Ch

BIT	FUNCTION	TYPE	DESCRIPTION	EEPROM/ I2C-SMBUS	DEFAULT
7:0	Interrupt Line	RW	The interrupt line register communicates interrupt line routing information.	No	00h

9.6.16 INTERRUPT PIN REGISTER – OFFSET 3Ch

BIT	FUNCTION	TYPE	DESCRIPTION	EEPROM/ I2C-SMBUS	DEFAULT
15:8	Interrupt Pin	RO	The Switch implements INTB virtual wire interrupt signal.	No	02h

9.6.17 POWER MANAGEMENT CAPABILITIES REGISTER – OFFSET 40h

BIT	FUNCTION	TYPE	DESCRIPTION	EEPROM/ I2C-SMBUS	DEFAULT
7:0	Enhanced Capabilities ID	RO	Read as 01h to indicate that this is power management capability register.	No	01h
15:8	Next Item Pointer	RO	Point to next PCI capability structure.	No	48h
18:16	Power Management Revision	RO	Read as 011b to indicate the device is compliant to Revision 1.2 of <i>PCI Power Management Interface Specifications</i> .	No	011b
19	PME# Clock	RsvdP	Not support.	No	0
20	Reserved	RsvdP	Not support.	No	0
21	Device Specific Initialization	RO	Read as 0b to indicate Switch does not have device specific initialization requirements.	No	0
24:22	AUX Current	RO	Reset to 0.	No	000b
25	D1 Power State Support	RO	Read as 0b to indicate Switch does Not support the D1 power management state.	No	0
26	D2 Power State Support	RO	Read as 0b to indicate Switch does Not support the D2 power management state.	No	0
31:27	PME# Support	RO	Read as 19h to indicate Switch supports the forwarding of PME# message in D0, D3 and D4 states.	No	19h

9.6.18 POWER MANAGEMENT DATA REGISTER – OFFSET 44h

BIT	FUNCTION	TYPE	DESCRIPTION	EEPROM/ I2C-SMBUS	DEFAULT
1:0	Power State	RW	Indicates the current power state of the Switch. Writing a value of D0 when the previous state was D3 cause a hot reset without asserting DWRST_L. 00b: D0 state 01b: D1 state 10b: D2 state 11b: D3 hot state	No	00b
2	Reserved	RsvdP	Not support.	No	0
3	No_Soft_Reset	RO	When set, this bit indicates that device transitioning from D3hot to D0 does not perform an internal reset. When clear, an internal reset is performed when power state transits from D3hot to D0.	No	1
7:4	Reserved	RsvdP	Not support.	No	0h
8	PME# Enable	RW	When asserted, the Switch will generate the PME# message.	No	0
12:9	Data Select	RO	Select data registers.	No	0h
14:13	Data Scale	RO	Reset to 00b.	No	00b
15	PME Status	RW1C	Read as 0b as the PME# message is not implemented.	No	0

9.6.19 PPB SUPPORT EXTENSIONS – OFFSET 44h

BIT	FUNCTION	TYPE	DESCRIPTION	EEPROM/ I2C-SMBUS	DEFAULT
21:16	Reserved	RsvdP	Not support.	No	00_0000b
22	B2_B3 Support for D3 _{HOT}	RO	Does not apply to PCI Express. Must be hardwired to 0.	No	0
23	Bus Power / Clock Control Enable	RO	Does not apply to PCI Express. Must be hardwired to 0.	No	0

9.6.20 DATA REGISTER – OFFSET 44h

BIT	FUNCTION	TYPE	DESCRIPTION	EEPROM/ I2C-SMBUS	DEFAULT
31:24	Data Register	RO	Data Register.	No	00h

9.6.21 MSI CAPABILITIES REGISTER – OFFSET 48h

BIT	FUNCTION	TYPE	DESCRIPTION	EEPROM/ I2C-SMBUS	DEFAULT
7:0	Enhanced Capabilities ID	RO	Read as 05h to indicate that this is message signal interrupt capability register.	No	05h
15:8	Next Item Pointer	RO	Point to next PCI capability structure.	No	68h
16	MSI Enable	RW	0b: The function is prohibited from using MSI to request service 1b: The function is permitted to use MSI to request service and is prohibited from using its INTx # pin	No	0
19:17	Multiple Message Capable	RO	Request 8 multiple vectors to system. Each vector is corresponding to each virtual channel	No	011b
22:20	Multiple Message Enable	RW	System software writes to this field indicating the numbers of vectors are allocated. 000b: one vector allocated. All 4 dma virtual channels share this MSI 001b: two vectors allocated. DVC0~1 use MSI#0 while DVC4~5 use MSI#1 010b: the same as 001b 011b: four vectors allocated and each DVC uses its own MSI DVC0 (MSI#0), DVC1 (MSI#1), DVC4 (MSI#4), DVC5 (MSI#5)	No	000b
23	64-bit address capable	RO	0b: The function is not capable of generating a 64-bit message address 1b: The function is capable of generating a 64-bit message address	No	1
24	Per-vector masking capable	RO	0b: the function support MSI per-vector masking. 1b: the function does Not support MSI per-vector masking.	No	1
31:25	Reserved	RsvdP	Not support.	No	00h

9.6.22 MESSAGE ADDRESS REGISTER – OFFSET 4Ch

BIT	FUNCTION	TYPE	DESCRIPTION	EEPROM/ I2C-SMBUS	DEFAULT
1:0	Reserved	RsvdP	Not support.	No	00b
31:2	Message Address	RW	If the message enable bit is set, the contents of this register specify the DWORD aligned address for MSI memory write transaction.	No	0-0h

9.6.23 MESSAGE UPPER ADDRESS REGISTER – OFFSET 50h

BIT	FUNCTION	TYPE	DESCRIPTION	EEPROM/ I2C-SMBUS	DEFAULT
31:0	Message Upper Address	RW	This register is only effective if the device supports a 64-bit message address is set.	No	0000_0000h

9.6.24 MESSAGE DATA REGISTER – OFFSET 54h

BIT	FUNCTION	TYPE	DESCRIPTION	EEPROM/ I2C-SMBUS	DEFAULT
15:0	Message Data	RW	Reset to 0.	No	0000h
31:16	Reserved	RsvdP	Not support.	No	0000h

9.6.25 MESSAGE MASK REGISTER – OFFSET 58h

BIT	FUNCTION	TYPE	DESCRIPTION	EEPROM/ I2C-SMBUS	DEFAULT
0	MSI Mask for DVC0 Interrupt	RW	MSI mask for DMA Virtual Channel 0 Interrupt	No	0
1	MSI Mask for DVC1 Interrupt	RW	MSI mask for DMA Virtual Channel 1 Interrupt	No	0
2	Reserved	RsvdP	Not support.	No	0
3	Reserved	RsvdP	Not support.	No	0
4	MSI Mask for DVC4 Interrupt	RW	MSI mask for DMA Virtual Channel 4 Interrupt	No	0
5	MSI Mask for DVC5 Interrupt	RW	MSI mask for DMA Virtual Channel 5 Interrupt	No	0
6	Reserved	RsvdP	Not support.	No	0
7	Reserved	RsvdP	Not support.	No	0
31:8	Reserved	RsvdP	Not support.	No	0000_000h

9.6.26 MESSAGE PENDING REGISTER – OFFSET 5Ch

BIT	FUNCTION	TYPE	DESCRIPTION	EEPROM/ I2C-SMBUS	DEFAULT
0	MSI Pending for DVC0 Interrupt	RO	MSI pending status for DMA Virtual Channel 0 Interrupt	No	0
1	MSI Pending for DVC1 Interrupt	RO	MSI pending status for DMA Virtual Channel 1 Interrupt	No	0
2	Reserved	RsvdP	Not support.	No	0
3	Reserved	RsvdP	Not support.	No	0
4	MSI Pending for DVC4 Interrupt	RO	MSI pending status for DMA Virtual Channel 4 Interrupt	No	0
5	MSI Pending for DVC5 Interrupt	RO	MSI pending status for DMA Virtual Channel 5 Interrupt	No	0
6	Reserved	RsvdP	Not support.	No	0
7	Reserved	RsvdP	Not support.	No	0
31:8	Reserved	RsvdP	Not support.	No	0000_000h

9.6.27 PCI EXPRESS CAPABILITIES REGISTER – OFFSET 68h

BIT	FUNCTION	TYPE	DESCRIPTION	EEPROM/ I2C-SMBUS	DEFAULT
7:0	Enhanced Capabilities ID	RO	Read as 10h to indicate that this is PCI express enhanced capability register.	No	10h
15:8	Next Item Pointer	RO	Point to next PCI capability structure.	No	A4h
19:16	Capability Version	RO	Read as 2h to indicate the device is compliant to Revision .2.0 of <i>PCI Express Base Specifications</i> .	No	2h
23:20	Device/Port Type	RO	Indicates the type of PCI Express logical device.	No	0h
24	Slot Implemented	RO	Reset to 0b.	No	0
29:25	Interrupt Message Number	RO	Read as 0. No MSI messages are generated in the transparent mode.	No	00_000b
31:30	Reserved	RsvdP	Not support.	No	00b

9.6.28 DEVICE CAPABILITIES REGISTER – OFFSET 6Ch

BIT	FUNCTION	TYPE	DESCRIPTION	EEPROM/ I2C-SMBUS	DEFAULT
2:0	Max_Payload_Size Supported	RO	Indicates the maximum payload size that the device can support for TLPs. Each port of the Switch supports 512 bytes max payload size.	No	010b
4:3	Phantom Functions Supported	RO	Indicates the support for use of unclaimed function numbers as Phantom functions. Read as 00b, since no function number bits are used as phantom functions.	No	00b
5	Extended Tag Field Supported	RO	Indicates the maximum supported size of Tag field as a Requester. Read as 0, since the function supports 5-bit tage field only.	No	0

BIT	FUNCTION	TYPE	DESCRIPTION	EEPROM/ I2C-SMBUS	DEFAULT
8:6	Endpoint L0s Acceptable Latency	RO	Acceptable total latency that an Endpoint can withstand due to the transition from L0s state to the L0 state. For Switch, the ASPM software would not check this value.	No	000b
11:9	Endpoint L1 Acceptable Latency	RO	Acceptable total latency that an Endpoint can withstand due to the transition from L1 state to the L0 state. For Switch, the ASPM software would not check this value.	No	000b
14:12	Reserved	RsvdP	Not support.	No	000b
15	Role_Based Error Reporting	RO	When set, indicates that the device implements the functionality originally defined in the Error Reporting ECN.	No	1
17:16	Reserved	RsvdP	Not support.	No	00b
25:18	Captured Slot Power Limit Value	RO	In combination with the Slot Power Limit Scale value, specifies the upper limit on power supplied by slot. This value is set by the Set_Slot_Power_Limit message or hardwired to 00h.	No	00h
27:26	Captured Slot Power Limit Scale	RO	Specifies the scale used for the Slot Power Limit Value. This value is set by the Set_Slot_Power_Limit message or hardwired to 00b.	No	00b
31:28	Reserved	RsvdP	Not support.	No	0h

9.6.29 DEVICE CONTROL REGISTER – OFFSET 70h

BIT	FUNCTION	TYPE	DESCRIPTION	EEPROM/ I2C-SMBUS	DEFAULT
0	Correctable Error Reporting Enable	RW	0b: Disable Correctable Error Reporting 1b: Enable Correctable Error Reporting	No	0
1	Non-Fatal Error Reporting Enable	RW	0b: Disable Non-Fatal Error Reporting 1b: Enable Non-Fatal Error Reporting	No	0
2	Fatal Error Reporting Enable	RW	0b: Disable Fatal Error Reporting 1b: Enable Fatal Error Reporting	No	0
3	Unsupported Request Reporting Enable	RW	0b: Disable Unsupported Request Reporting 1b: Enable Unsupported Request Reporting	No	0
4	Enable Relaxed Ordering	RO	When set, it permits the device to set the Relaxed Ordering bit in the attribute field of transaction.	No	0
7:5	Max_Payload_Size	RW	This field sets maximum TLP payload size for the device. Permissible values that can be programmed are indicated by the Max_Payload_Size Supported in the Device Capabilities register. Any value exceeding the Max_Payload_Size Supported written to this register results into clamping to the Max_Payload_Size Supported value.	No	000b
8	Extended Tag Field Enable	RW	Returns '0' when read, since extended tag field is Not supported.	No	0
9	Phantom Function Enable	RW	Returns '0' when read, since Phantom Function is Not supported.	No	0
10	Auxiliary (AUX) Power PM Enable	RO	When set, indicates that a device is enabled to draw AUX power independent of PME AUX power.	No	0
11	Enable No Snoop	RW	When set, it permits to set the No Snoop bit in the attribute field of transaction.	No	0
14:12	Max_Read_Request_Size	RW	This field sets the maximum Read Request size for the device as a Requester. The function must not generate Read Requests with a size exceeding the set value.	No	010b
15	Reserved	RsvdP	Not support.	No	0

9.6.30 DEVICE STATUS REGISTER – OFFSET 70h

BIT	FUNCTION	TYPE	DESCRIPTION	EEPROM/ I2C-SMBUS	DEFAULT
16	Correctable Error Detected	RW1C	Asserted when correctable error is detected. Errors are logged in this register regardless of whether error reporting is enabled or not in the Device Control register.	No	0

BIT	FUNCTION	TYPE	DESCRIPTION	EEPROM/ I2C-SMBUS	DEFAULT
17	Non-Fatal Error Detected	RW1C	Asserted when non-fatal error is detected. Errors are logged in this register regardless of whether error reporting is enabled or not in the Device Control register.	No	0
18	Fatal Error Detected	RW1C	Asserted when fatal error is detected. Errors are logged in this register regardless of whether error reporting is enabled or not in the Device Control register.	No	0
19	Unsupported Request Detected	RW1C	Asserted when unsupported request is detected. Errors are logged in this register regardless of whether error reporting is enabled or not in the Device Control register.	No	0
20	AUX Power Detected	RO	Asserted when the AUX power is detected by the Switch	No	0
21	Transactions Pending	RO	Each port of Switch does not issue Non-posted Requests on its own behalf, so this bit is hardwired to 0b.	No	0
31:22	Reserved	RsvdP	Not support.	No	0-0h

9.6.31 LINK CAPABILITIES REGISTER – OFFSET 74h

BIT	FUNCTION	TYPE	DESCRIPTION	EEPROM/ I2C-SMBUS	DEFAULT
3:0	Maximum Link Speed	RO	Indicates the maximum speed of the Express link is 8Gb/s, 5Gb/s and 2.5 Gb/s. 0001b: 2.5 Gb/s 0010b: 5.0 Gb/s 0011b: 8.0 Gb/s Others: Reserved	No	3h
9:4	Maximum Link Width	RO	Indicates the maximum width of the given PCIe Link.	No	00_0000b
11:10	Active State Power Management (ASPM) Support	RO	Indicates the level of ASPM supported on the given PCIe Link. Each port of Switch supports L0s and L1 entry.	No	10b
14:12	L0s Exit Latency	RO	Indicates the L0s exit latency for the given PCIe Link. The length of time this port requires to complete transition from L0s to L0 is in the range of 256ns to less than 512ns.	No	011b
17:15	L1 Exit Latency	RO	Indicates the L1 exit latency for the given PCIe Link. The length of time this port requires to complete transition from L1 to L0 is less than 1us.	No	000b
18	Clock Power Management	RO	This bit must be hardwired to 0b.	No	0
19	Surprise Down Capability Enable	RsvdP	Not support.	No	0
20	Data Link Layer Active Reporting Capable	RsvdP	Not support.	No	0
21	Link BW Notify Capability	RsvdP	Not support.	No	0
23:20	Reserved	RsvdP	Not support.	No	0-0h
31:24	Port Number	RO	The Port Number is same as Function 0	No	90h

9.6.32 LINK CONTROL REGISTER – OFFSET 78h

BIT	FUNCTION	TYPE	DESCRIPTION	EEPROM/ I2C-SMBUS	DEFAULT
1:0	Active State Power Management (ASPM) Control	RW	00b: ASPM is Disabled 01b: L0s Entry Enabled 10b: L1 Entry Enabled 11b: L0s and L1 Entry Enabled Note that the receiver must be capable of entering L0s even when the field is disabled It is strongly recommended for programming the same value as does in function 0.	No	00b
2	Reserved	RsvdP	Not support.	No	0

BIT	FUNCTION	TYPE	DESCRIPTION	EEPROM/ I2C-SMBUS	DEFAULT
3	Read Completion Boundary (RCB)	RO	The function does not implement RCB. Returns '0' when read.	No	0
4	Link Disable	RsvdP	Not supported.	No	0
5	Retrain Link	RsvdP	Not supported.	No	0
6	Common Clock Configuration	RO	0b: The components at both ends of a link are operating with synchronous reference clock. 1b: The components at both ends of a link are operating with a distributed common reference clock It is strongly recommended for programming the same value as does in function 0.	No	0
7	Extended Synch	RO	When set, it transmits 4096 FTS ordered sets in the L0s state for entering L0 state and transmits 1024 TS1 ordered sets in the L1 state for entering L0 state. If any function has this bit set, then the component must transmit additional ordering set when leaving L0s or when in Recovery.	No	0
8	Enable Clock Power Management	RsvdP	Not support.	No	0
9	HW Autonomous Width Disable	RO	Reset to 0b.	No	0
10	Link Bandwidth Management Interrupt Enable	RO	Reset to 0b.	No	0
11	Link Autonomous Bandwidth Interrupt Enable	RO	Reset to 0b.	No	0
15:12	Reserved	RsvdP	Not support.	No	00h

9.6.33 LINK STATUS REGISTER – OFFSET 78h

BIT	FUNCTION	TYPE	DESCRIPTION	EEPROM/ I2C-SMBUS	DEFAULT
19:16	Link Speed	RO	Indicate the negotiated speed of the Express link. 0001b: 2.5 Gb/s. 0010b: 5.0 Gb/s 0011b: 8.0 Gb/s Others: Reserved	No	0h
25:20	Negotiated Link Width	RO	Indicates the negotiated width of the given PCIe link.	No	00_0000b
26	Training Error	RsvdP	Not supported.	No	0
27	Link Training	RsvdP	Not supported.	No	0
28	Slot Clock Configuration	RO	0b: the function uses an independent clock corresponsive of the presence of a reference on the connector 1b: the function uses the same reference clock that the platform provides on the connector For multi-function endpoint, each function must report the same the same value as function 0.	No	0
29	Data Link Layer Link Active	RsvdP	Not support.	No	0
30	Link Bandwidth Management Status	RO	Reset to 0b.	No	0
31	Link Autonomous Bandwidth Status	RO	Reset to 0b.	No	0

9.6.34 DEVICE CAPABILITIES REGISTER 2 – OFFSET 8Ch

BIT	FUNCTION	TYPE	DESCRIPTION	EEPROM/ I2C-SMBUS	DEFAULT
3:0	CTO Range	RO	Completion Timeout Ranges: Support Range A (i.e. 50us to 10ms)	Yes	0001b

BIT	FUNCTION	TYPE	DESCRIPTION	EEPROM/ I2C-SMBUS	DEFAULT
4	CTO Disable	RO	Completion Timeout Disable: Not supported. Returned 0 when read.	Yes	0
5	ARI Forwarding Supported	RO	0b: ARI forwarding is Not supported 1b: ARI forwarding is supported	Yes	1
6	Reserved	RsvdP	Not support.	No	0
10:7	Reserved	RsvdP	Not support.	No	0-0h
11	LTR Mechanism Supported	RO	A value of 1b indicates support for the optional Latency Tolerance Reporting (LTR) mechanism.	Yes	0
17:12	Reserved	RsvdP	Not support.	No	0-0h
19:18	OBFF Supported	RO	This field indicates if OBFF is supported.	Yes	00b
31:20	Reserved	RsvdP	Not support.	No	000h

9.6.35 DEVICE CONTROL and STATUS REGISTER 2 – OFFSET 90h

BIT	FUNCTION	TYPE	DESCRIPTION	EEPROM/ I2C-SMBUS	DEFAULT
3:0	CTO Value	RW	Completion Timeout Value: For Range A supported, the valid values are as follows. 0000b: 50us to 50ms 0001b: 50us to 100us 0010b: 1ms to 10ms 0101b: 16ms to 55ms 0110b: 65ms to 210ms The default value is 0000b, which represents a range of 50us to 50ms.	No	0000b
4	CTO Disable	RW	Completion Timeout Disable: Not supported. Returned 0 when read.	No	0
31:5	Reserved	RsvdP	Not support.	No	00000h

9.6.36 LINK CAPABILITY REGISTER 2 – OFFSET 94h

BIT	FUNCTION	TYPE	DESCRIPTION	EEPROM/ I2C-SMBUS	DEFAULT
0	Reserved	RsvdP	Not support.	No	0
7:1	Supported Link Speeds Vector	RO	This field indicates the supported Link speed of the associated Port. bit[0]... 2.5 GT/s bit[1]... 5.0 GT/s bit[2]... 8.0 GT/s bit[6:3]... RsvdP	No	0000_111b
8	Crosslink Supported	RO	0b: Crosslink is Not supported 1b: Crosslink is supported	No	0
31:9	Reserved	RsvdP	Not support.	No	0-0b

9.6.37 LINK CONTROL REGISTER 2 – OFFSET 98h

BIT	FUNCTION	TYPE	DESCRIPTION	EEPROM/ I2C-SMBUS	DEFAULT
3:0	Target Link Speed	RO	0001b: 2.5GT/s link speed is supported 0010b: 5.0GT/s link speed is supported 0011b: 8.0GT/s link speed is supported Others: reserved.	No	3h
4	Enter Compliance	RO	1b: enter compliance	No	0
5	HW_AutoSpeed_Dis	RO	When set, this bit disables hardware from changing the link speed for device-specific reasons other than attempting to correct unreliable link operation by reducing link speed.	No	0
6	Select_Deemp	RO	Valid for downstream ports only. 0b: Select -3.5db de-emphasis 1b: Select -6.0 db de-emphasis	No	0

BIT	FUNCTION	TYPE	DESCRIPTION	EEPROM/ I2C-SMBUS	DEFAULT
9:7	Tran_Margin	RO	This field controls the value of the non-deemphasized voltage level at the transmitter pins.	No	000b
10	Enter Modify Compliance	RO	Valid for upstream port only. When set, the device transmits modified compliance pattern if the LTSSM enters Polling.Compliance substate.	No	0
11	Compliance SOS	RO	Valid for upstream port only. When set, the LTSSM is required to send SKP Ordered Sets between sequences when sending the Compliance Pattern or Modified Compliance Pattern.	No	0
15:12	Compliance Preset/De-emphasis	RO	This field is intended for debug and compliance testing purpose.	No	0000b

9.6.38 LINK STATUS REGISTER 2 – OFFSET 98h

BIT	FUNCTION	TYPE	DESCRIPTION	EEPROM/ I2C-SMBUS	DEFAULT
16	Current De-emphasis level	RO	0b: -6dB 1b: -3.5dB	No	0
31:17	Link status 2	RO	Reset to 0.	No	0-0h

9.6.39 SSID/SSVID CAPABILITIES REGISTER – OFFSET A4h

BIT	FUNCTION	TYPE	DESCRIPTION	EEPROM/ I2C-SMBUS	DEFAULT
7:0	SSID/SSVID Capabilities ID	RO	Read as 0Dh to indicate that this is SSID/SSVID capability register.	No	0Dh
15:8	Next Item Pointer	RO	Read as 00h. No other ECP registers.	No	00h
31:16	Reserved	RsvdP	Not support.	No	0000h

9.6.40 SUBSYSTEM VENDOR ID REGISTER – OFFSET A8h

BIT	FUNCTION	TYPE	DESCRIPTION	EEPROM/ I2C-SMBUS	DEFAULT
15:0	SSVID	RO	It indicates the sub-system vendor id.	No	12D8h

9.6.41 SUBSYSTEM ID REGISTER – OFFSET A8h

BIT	FUNCTION	TYPE	DESCRIPTION	EEPROM/ I2C-SMBUS	DEFAULT
31:16	SSID	RO	It indicates the sub-system device id.	No	C016h

9.6.42 PCI EXPRESS ADVANCED ERROR REPORTING ENHANCED CAPABILITY HEADER REGISTER – OFFSET 100h

BIT	FUNCTION	TYPE	DESCRIPTION	EEPROM/ I2C-SMBUS	DEFAULT
15:0	Extended Capabilities ID	RO	Read as 0001h to indicate that this is PCI express extended capability register for advance error reporting.	No	0001h
19:16	Capability Version	RO	Read as 1h.	No	1h
31:20	Next Capability Offset	RO	No ECP	No	000h

9.6.43 UNCORRECTABLE ERROR STATUS REGISTER – OFFSET 104h

BIT	FUNCTION	TYPE	DESCRIPTION	EEPROM/ I2C-SMBUS	DEFAULT
0	Training Error Status	RW1C	When set, indicates that the Training Error event has occurred.	No	0

BIT	FUNCTION	TYPE	DESCRIPTION	EEPROM/ I2C-SMBUS	DEFAULT
3:1	Reserved	RsvdP	Not support.	No	000
4	Data Link Protocol Error Status	RW1C	When set, indicates that the Data Link Protocol Error event has occurred.	No	0
5	Surprise Down Error Status	RW1C	When set, indicates that the Surprise Down Error event has occurred. Valid for Downstream ports only.	No	0
11:6	Reserved	RsvdP	Not support.	No	0-0b
12	Poisoned TLP Status	RW1C	When set, indicates that a Poisoned TLP has been received or generated.	No	0
13	Flow Control Protocol Error Status	RW1C	When set, indicates that the Flow Control Protocol Error event has occurred.	No	0
14	Completion Timeout Status	RW1C	When set, indicates that the Completion Timeout event has occurred.	No	0
15	Completer AbortStatus	RW1C	When set, indicates that the Completer Abort event has occurred.	No	0
16	Unexpected Completion Status	RW1C	When set, indicates that the Unexpected Completion event has occurred.	No	0
17	Receiver Overflow Status	RW1C	When set, indicates that the Receiver Overflow event has occurred.	No	0
18	Malformed TLP Status	RW1C	When set, indicates that a Malformed TLP has been received.	No	0
19	ECRC Error Status	RW1C	When set, indicates that an ECRC Error has been detected.	No	0
20	Unsupported Request Error Status	RW1C	When set, indicates that an Unsupported Request event has occurred.	No	0
21	ACS Violation Status	RW1C	When set, indicates that an ACS Violation event has occurred Valid for Downstream ports only.	No	0
22	Internal Error Status	RW1C	When set, indicates that an Internal Error has occurred.	No	0
23	MC Blocked TLP Status	RW1C	When set, indicates that an MC Blocked TLP event has occurred.	No	0
24	AtomicOp Egress Blocked Status	RW1C	When set, indicates that an AtomicOp Egress Blocked event has occurred.	No	0
31:25	Reserved	RsvdP	Not support.	No	0000_000b

9.6.44 UNCORRECTABLE ERROR MASK REGISTER – OFFSET 108h

BIT	FUNCTION	TYPE	DESCRIPTION	EEPROM/ I2C-SMBUS	DEFAULT
0	Training Error Mask	RW	When set, the Training Error event is not logged in the Header Log register and not issued as an Error Message to RC either.	No	0
3:1	Reserved	RsvdP	Not support.	No	000b
4	Data Link Protocol Error Mask	RW	When set, the Data Link Protocol Error event is not logged in the Header Log register and not issued as an Error Message to RC either.	No	0
5	Surprise Down Error Mask	RW	When set, Surprise Down Error event is not logged in the Header Log register and not issued as an Error Message to RC either. Valid for Downstream ports only.	No	0
11:6	Reserved	RsvdP	Not support.	No	0-0b
12	Poisoned TLP Mask	RW	When set, an event of Poisoned TLP has been received or generated is not logged in the Header Log register and not issued as an Error Message to RC either.	No	0
13	Flow Control Protocol Error Mask	RW	When set, the Flow Control Protocol Error event is not logged in the Header Log register and not issued as an Error Message to RC either.	No	0
14	Completion Timeout Mask	RW	When set, the Completion Timeout event is not logged in the Header Log register and not issued as an Error Message to RC either.	No	0
15	Completer AbortMask	RW	When set, the Completer Abort event is not logged in the Header Log register and not issued as an Error Message to RC either.	No	0

BIT	FUNCTION	TYPE	DESCRIPTION	EEPROM/ I2C-SMBUS	DEFAULT
16	Unexpected Completion Mask	RW	When set, the Unexpected Completion event is not logged in the Header Log register and not issued as an Error Message to RC either.	No	0
17	Receiver Overflow Mask	RW	When set, the Receiver Overflow event is not logged in the Header Log register and not issued as an Error Message to RC either.	No	0
18	Malformed TLP Mask	RW	When set, an event of Malformed TLP has been received is not logged in the Header Log register and not issued as an Error Message to RC either.	No	0
19	ECRC Error Mask	RW	When set, an event of ECRC Error has been detected is not logged in the Header Log register and not issued as an Error Message to RC either.	No	0
20	Unsupported Request Error Mask	RW	When set, the Unsupported Request event is not logged in the Header Log register and not issued as an Error Message to RC either.	No	0
21	ACS Violation Mask	RW	When set, the ACS Violation event is not logged in the Header Log register and not issued as an Error Message to RC either. Valid for Downstream ports only.	No	0
22	Internal Error Mask	RW	When set, the Internal Error is not logged in the Header Log register and not issued as an Error Message to RC either.	No	1
23	MC Blocked TLP Mask	RW	When set, the MC Blocked TLP event is not logged in the Header Log register and not issued as an Error Message to RC either.	No	0
24	AtomicOp Egress Blocked Mask	RW	When set, the AtomicOp Egress Blocked event is not logged in the Header Log register and not issued as an Error Message to RC either.	No	0
31:25	Reserved	RsvdP	Not support.	No	0000_000b

9.6.45 UNCORRECTABLE ERROR SEVERITY REGISTER – OFFSET 10Ch

BIT	FUNCTION	TYPE	DESCRIPTION	EEPROM/ I2C-SMBUS	DEFAULT
0	Training Error Severity	RW	0b: Non-Fatal 1b: Fatal	No	1
3:1	Reserved	RsvdP	Not support.	No	000b
4	Data Link Protocol Error Severity	RW	0b: Non-Fatal 1b: Fatal	No	1
5	Surprise Down Error Severity	RW	0b: Non-Fatal 1b: Fatal	No	1
11:6	Reserved	RsvdP	Not support.	No	0-0b
12	Poisoned TLP Severity	RW	0b: Non-Fatal 1b: Fatal	No	0
13	Flow Control Protocol Error Severity	RW	0b: Non-Fatal 1b: Fatal	No	1
14	Completion Timeout Error Severity	RW	0b: Non-Fatal 1b: Fatal	No	0
15	Completer AbortSeverity	RW	0b: Non-Fatal 1b: Fatal	No	0
16	Unexpected Completion Severity	RW	0b: Non-Fatal 1b: Fatal	No	0
17	Receiver Overflow Severity	RW	0b: Non-Fatal 1b: Fatal	No	1
18	Malformed TLP Severity	RW	0b: Non-Fatal 1b: Fatal	No	1
19	ECRC Error Severity	RW	0b: Non-Fatal 1b: Fatal	No	0
20	Unsupported Request Error Severity	RW	0b: Non-Fatal 1b: Fatal	No	0
21	ACS Violation Severity	RW	0b: Non-Fatal 1b: Fatal	No	0
22	Internal Error Severity	RW	0b: Non-Fatal 1b: Fatal	No	1
23	MC Blocked TLP Severity	RW	0b: Non-Fatal 1b: Fatal	No	0

BIT	FUNCTION	TYPE	DESCRIPTION	EEPROM/ I2C-SMBUS	DEFAULT
24	AtomicOp Egress Blocked Severity	RW	0b: Non-Fatal 1b: Fatal	No	0
31:25	Reserved	RsvdP	Not support.	No	0000_000b

9.6.46 CORRECTABLE ERROR STATUS REGISTER – OFFSET 110h

BIT	FUNCTION	TYPE	DESCRIPTION	EEPROM/ I2C-SMBUS	DEFAULT
0	Receiver Error Status	RW1C	When set, the Receiver Error event is detected.	No	0
5:1	Reserved	RsvdP	Not support.	No	0_000b
6	Bad TLPStatus	RW1C	When set, the event of Bad TLP has been received is detected.	No	0
7	Bad DLLP Status	RW1C	When set, the event of Bad DLLP has been received is detected.	No	0
8	REPLAY_NUM Rollover status	RW1C	When set, the REPLAY_NUM Rollover event is detected.	No	0
11:9	Reserved	RsvdP	Not support.	No	000b
12	Replay Timer Timeout status	RW1C	When set, the Replay Timer Timeout event is detected.	No	0
13	Advisory Non-Fatal Error status	RW1C	When set, the Advisory Non-Fatal Error event is detected.	No	0
31:14	Reserved	RsvdP	Not support.	No	0-0h

9.6.47 CORRECTABLE ERROR MASK REGISTER – OFFSET 114h

BIT	FUNCTION	TYPE	DESCRIPTION	EEPROM/ I2C-SMBUS	DEFAULT
0	Receiver Error Mask	RW	When set, the Receiver Error event is not logged in the Header Log register and not issued as an Error Message to RC either.	No	0
5:1	Reserved	RsvdP	Not support.	No	0_000b
6	Bad TLPMask	RW	When set, the event of Bad TLP has been received is not logged in the Header Log register and not issued as an Error Message to RC either.	No	0
7	Bad DLLP Mask	RW	When set, the event of Bad DLLP has been received is not logged in the Header Log register and not issued as an Error Message to RC either.	No	0
8	REPLAY_NUM Rollover Mask	RW	When set, the REPLAY_NUM Rollover event is not logged in the Header Log register and not issued as an Error Message to RC either.	No	0
11:9	Reserved	RsvdP	Not support.	No	000b
12	Replay Timer Timeout Mask	RW	When set, the Replay Timer Timeout event is not logged in the Header Log register and not issued as an Error Message to RC either.	No	0
13	Advisory Non-Fatal Error Mask	RW	When set, the Advisory Non-Fatal Error event is not logged in the Header Long register and not issued as an Error Message to RC either.	No	1
31:14	Reserved	RsvdP	Not support.	No	0-0h

9.6.48 ADVANCE ERROR CAPABILITIES AND CONTROL REGISTER – OFFSET 118h

BIT	FUNCTION	TYPE	DESCRIPTION	EEPROM/ I2C-SMBUS	DEFAULT
4:0	First Error Pointer	RO	It indicates the bit position of the first error reported in the Uncorrectable Error Status register.	No	0_0000b
5	ECRC Generation Capable	RO	When set, it indicates the Switch has the capability to generate ECRC.	No	1
6	ECRC Generation Enable	RW	When set, it enables the generation of ECRC when needed.	No	0
7	ECRC Check Capable	RO	When set, it indicates the Switch has the capability to check ECRC.	No	1
8	ECRC Check Enable	RW	When set, the function of checking ECRC is enabled.	No	0
9	Multiple Header Recording Capable	RO	Not support multiple header recording capability.	No	0

BIT	FUNCTION	TYPE	DESCRIPTION	EEPROM/ I2C-SMBUS	DEFAULT
31:10	Reserved	RsvdP	Not support.	No	0-0h

9.6.49 HEADER LOG REGISTER – OFFSET From 11Ch to 128h

BIT	FUNCTION	TYPE	DESCRIPTION	EEPROM/ I2C-SMBUS	DEFAULT
31:0	1 st DWORD	RO	Hold the 1st DWORD of TLP Header. The Head byte is in big endian.	No	0000_0000h
63:32	2 nd DWORD	RO	Hold the 2nd DWORD of TLP Header. The Head byte is in big endian.	No	0000_0000h
95:64	3 rd DWORD	RO	Hold the 3rd DWORD of TLP Header. The Head byte is in big endian.	No	0000_0000h
127:96	4 th DWORD	RO	Hold the 4th DWORD of TLP Header. The Head byte is in big endian.	No	0000_0000h

9.7 DMA ENGINE INTERFACE REGISTERS

To enable DMA function, the packet switch defines a set of interface registers for software to control the DMA engine and monitor the status of DMA transfer. There are two DMA engines (DMA_0 and DMA_1) in this Switch to face either one common or two different CPU domains respectively, so it defines an independent interface for software to access its own registers in its own CPU domain. The interface registers contain per-channel DMA control and status registers, descriptor ownership registers, descriptor pointer registers and property registers (such as max payload size, max read request size and bus number of CDEP port etc.) for cross-domain DMA transfer.

The interface registers are mapped to multiple 256-byte register blocks in memory mode and each 256-byte register block represents one channel. The register blocks can be accessed by the DMA Memory Base Address, which is obtained by DMA Base Address Register 0 (Func1, CFG offset 10h or Func2, CFG offset 10h based upon different DMA mode selection, and please note that each DMA engine is viewed as a PCIe function by enumeration).

Table 9-12: DMA Base Address in Memory Mode when DMA channels pertaining to the same host domain

DMA Engine	DMA Memory Base Address
Upstream Port CSR for Channel 0	Upstream Port BAR0 + 0000h
Upstream Port CSR for Channel 1	Upstream Port BAR0 + 0100h
N/A	Reserved
N/A	Reserved
Upstream Port CSR for Channel 4	Upstream Port BAR0 + 0400h
Upstream Port CSR for Channel 5	Upstream Port BAR0 + 0500h
N/A	Reserved
N/A	Reserved

Table 9-13: DMA Base Address in Memory Mode when DMA channels pertaining to different host domain

DMA Engine	DMA Memory Base Address
Upstream Port CSR for Channel 0	Upstream Port BAR0 + 0000h
Upstream Port CSR for Channel 4	Upstream Port BAR0 + 0400h
CDEP CSR for Channel 0	CDEP BAR0 + 0000h
CDEP CSR for Channel 4	CDEP BAR0 + 0400h

Following is a summary of addressing map for interface registers. Please note that the max.length for read/write register only supports 4 bytes.

31 – 24	23 – 16	15 – 8	7 – 0	BYTE OFFSET
DMA Status 0		DMA Control 0		00h
Descriptor Ownership 0				04h
Descriptor Ownership 1				08h
Channel Descriptor Ring Base Pointer (Low 32-bit)				0Ch
ChannelDescriptor Ring Base Pointer (High 32-bit)				10h
Channel Descriptor Current Pointer (Offset from Base Pointer)				14h
Channel Transfer Count Status of Current Descriptor Pointer				18h
Channel Gap Time Control		Reserved		1Ch
DMA Status 1		DMA Control 1		20h
Channel Descriptor Ring Size for Prefetch				24h
Domain 0~3 Max. Payload Size and Read Request Size				28h
Domain 4~7 Max. Payload Size and Read Request Size				2Ch
Domain 8~11 Max. Payload Size and Read Request Size				30h
Domain 0~3 Bus Number (Global)				34h
Domain 4~7 Bus Number (Global)				38h
Domain 8~11 Bus Number (Global)				3Ch
User Defined Attributes for DMA Operation				40h
Channel Uncorrectable Error Status				44h
Reserved				48h ~ 50h
DMA Read Threshold Control				5Ch
Reserved				60h~84h
DMA Hardware Control 0				88h
DMA Hardware Control 1 (Global)				8Ch
Reserved				90h ~ FFh

9.7.1 DMA CONTROL AND STATUS REGISTER 0 – OFFSET 00h

BIT	FUNCTION	TYPE	DESCRIPTION	DEFAULT
0	No Snooping Mode	RW	Configuration of No Snooping. 0b: Disable no snooping 1b: Enable no snooping	0
1	Address Format	RW	Indicate the addressing system a DMA operation is riding on. 0b: 32-bit addressing system 1b: 64-bit addressing system	0
2	CDEP Mapping Enable	RW	Mapping the CDEP channel of another DMA engine to the channel of current DMA engine. This field has to be programmed for inter-processor domain data transfer model. 0b: No Mapping (All DMA channels are managed by Root Host) 1b: Mapping to remote channel, The value is only for physical channels (i.e. channel ID are 0 and 4) When mapping value is not zero, the remote DMA shall be active.	0
4:3	CDEP Mapping Channel	RW	Select mapping remote physical channel ID. 00b: physical channel 0 (DMA 0 CH 0) 01b: physical channel 1 (DMA 0 CH 4) 10b: physical channel 2 (DMA 1 CH 0) 11b: physical channel 3 (DMA 1 CH 4)	00b
7:5	CDEP Mapping Switch	RW	It need be fixed to 000b.	000b
8	EOT Valid	RW	When set, the EOT bit in descriptor is valid under the condition of DMA channels managed by Root Host only. EOT bit will be updated from 0 to 1 by the switch once the data transfer indicated in that descriptor is ended.	0
16:9	Reserved	RsvP	Not support.	00h
17	UCE Interrupt Enable	RW	When set, Interrupt is issued when detecting Uncorrectable Error	0
18	Error Report Scheme	RW	When clear, DMA reports UCE event without writing DP TLP to destination address. When set, DMA reports UCE event after writing DP TLP to destination address	0
27:19	Reserved	RsvP	Not support.	0-0b
31:28	Channel ID	RO	Indicate the channel ID is used by which channel of DMA.	0h

9.7.2 DESCRIPTOR OWNERSHIP REGISTER 0 – OFFSET 04h

BIT	FUNCTION	TYPE	DESCRIPTION	DEFAULT
31:0	Descriptor Ownership 0	RW	Indicate the ownership of descriptor 0. That means the owner can access the buffer pointed by the address field of descriptor 0. 1b: the DMA channel owns the descriptor 0 0b: the DMA driver owns the descriptor 0 After the buffer prepared by DMA driver, it will write “1” to the corresponding descriptor ownership bit. After the descriptor is done, the DMA channel will clear the corresponding bit to “0”.	0000_000h

9.7.3 DESCRIPTOR OWNERSHIP REGISTER1 – OFFSET 08h

BIT	FUNCTION	TYPE	DESCRIPTION	DEFAULT
31:0	Descriptor Ownership 1	RW	<p>Indicate the ownership of descriptor. That means the owner can access the buffer pointed by the address field of descriptor 1.</p> <p>1b: the DMA channel owns the descriptor 1 0b: the DMA driver owns the descriptor 1</p> <p>After the buffer prepared by DMA driver, it will write “1” to the corresponding descriptor ownership bit. After the descriptor is done, the DMA channel will clear the corresponding bit to “0”.</p>	0000_000h

9.7.4 CHANNELDESCRIPTOR RING BASE POINTER (LOW 32-bit)REGISTER – OFFSET 0Ch

BIT	FUNCTION	TYPE	DESCRIPTION	DEFAULT
1:0	Reserved	RsvdP	Not support.	00b
31:2	Descriptor Ring Base Pointer (Low 32-bit)	RW	Lower 32-bit of Base Pointer referring to the 1 st entry of descriptor ring. It tells DMA channel where the descriptor is starting at. The base pointer is in 64-bit alignment.	0000_0000h

9.7.5 CHANNELDESCRIPTOR RING BASE POINTER (HIGH 32-bit) REGISTER – OFFSET 10h

BIT	FUNCTION	TYPE	DESCRIPTION	DEFAULT
31:0	Descriptor Ring Base Pointer (High 32-bit)	RW	Upper 32-bit of Base Pointer referring to the 1st entry of descriptor ring if 64-bit addressing system is used. It tells DMA channel where the descriptor is starting at.	0000_0000h

9.7.6 CHANNEL DESCRIPTOR CURRENT POINTER REGISTER – OFFSET 14h

BIT	FUNCTION	TYPE	DESCRIPTION	DEFAULT
11:0	Descriptor Current Pointer (Offset from Base Pointer)	RO	Indicating the current pointer (Offset from Base Pointer) referring to the descriptor that is under processing by DMA Engine in terms of index. A maximum of 4096 pointers are allowed.	000h
31:12	Reserved	RsvdP	Not support.	00000h

9.7.7 CHANNEL TRANSFER COUNT STATUS OF CURRENT DESCRIPTOR POINTER REGISTER – OFFSET 18h

BIT	FUNCTION	TYPE	DESCRIPTION	DEFAULT
23:0	Transfer Count Status	RO	Indicating how many byte counts have been not transferred for the current descriptor pointer.	00_0000h
31:24	Reserved	RsvdP	Not support.	00h

9.7.8 CHANNEL GAP TIME CONTROL REGISTER – OFFSET 1Ch

BIT	FUNCTION	TYPE	DESCRIPTION	DEFAULT
15:0	Write Data Gap Time Control	RW	Control the gap time between DMA writes. It is represented by 16 bits in a unit of 4ns	0000h
31:16	Fetch Data Gap Time Control	RW	Control the gap time between DMA reads. It is represented by 16 bits in a unit of 4ns	0000h

9.7.9 DMA CONTROL AND STATUS REGISTER 1 – OFFSET 20h

BIT	FUNCTION	TYPE	DESCRIPTION	DEFAULT
0	DMA Start	RWIO	<p>Start DMA operation.</p> <p>1b: the DMA operation starts to fetch and process the descriptors except the DMA stop or abort status is on.</p> <p>0b: the current pointer will be moved to the descriptor ring base pointer or next descriptor pointer and stop the DMA operation.</p> <p>This bit can only be written with “1” and will not take effect if written with “0”. Only when DMA operation is stopped or aborted, this bit will be automatically cleaned to “0”.</p>	0
1	DMA Pause Control	RW	<p>Pause DMA Operation. When set, the DMA operation is paused to the next active descriptor after completing the processing on current descriptor. It means that no more descriptors are processed and prefetched until the “Paused” condition is lifted.</p> <p>For Host-to-Host DMA operation, the remote-site has to pause its DMA operation at first and ensure the pause done status has been asserted. After that, the local-site is just allowed to pause DMA operation.</p> <p>If pause interrupt is enabled and pause control is also enabled, the interruptflagis asserted until cleared by software.</p>	0
2	DMA Abort Control	RW	<p>Abort DMA Operation. When set, the DMA operation drops the current active descriptor by flushing out all outstanding read commands and discarding all received completion data. The pointer will move to the next active descriptor. No more descriptors are processed and prefetched until the “Aborted” condition is lifted.</p> <p>All receiving data will be discarded if DMA abort asserted. Removing abort condition can only use DMA start control</p> <p>For Host-to-Host DMA operation, the remote-site has to abort its DMA operation at first and ensure the abort done status has been asserted. After that, the local-site is just allowed to abort DMA operation.</p> <p>If abort interrupt is enabled and abort control is also enabled, the interruptflagis asserted until cleared by software.</p>	0
3	DMA Pause Interrupt Enable	RW	When set, Interrupt is issued when DMA operation is paused.	0
4	Reserved	RsvdP	Not support.	0
5	DMA Stop Interrupt Enable	RW	When set, Interrupt is issued when DMA operation is stopped.	0
6	DMA Abort Interrupt Enable	RW	When set, Interrupt is issued when DMA operation is aborted.	0
7	DMA Stop Control	RWIC	<p>Stop DMA Operation. When set, the DMA operation drops the current active descriptor by flushing out all outstanding read commands and discarding all received completion data. The channel interface registers are all cleaned to default state except Interrupt flag bit if DMA stop enable is set earlier. No more descriptors are processed and prefetched.</p> <p>All receiving data will be discarded if DMA stop asserted. Removing stop condition can only use DMA start control</p> <p>For Host-to-Host DMA operation, the remote-site has to stop its DMA operation at first and ensure the stop done status has been asserted. After that, the local-site is just allowed to stop DMA operation.</p> <p>If stop interrupt is enabled and stop control is also enabled, the interrupt flag is asserted until cleaned by software</p>	0
8	Ownership Flush	RW	Clear ownership register when DMA operation is stopped.	0
15:9	Reserved	RsvdP	Not support.	00h
16	DMA Pause Done Status	RO	Indicates the DMA operation is in “Paused” condition. Removing pause done status can use DMA Pause control.	0
17	DMA Abort Done Status	RO	Indicates the DMA operation is in “Aborted” condition. Removing abort done status can only use DMA start control.	0
18	DMA Stop Done Status	RO	Indicates the DMA operation is in “Stopped” condition. Removing Stop done status can only use DMA start control.	1
30:19	Reserved	RsvdP	Not support.	000h

BIT	FUNCTION	TYPE	DESCRIPTION	DEFAULT
31	Interrupt Flag	RW1C	Indicates the interrupt asserted.	0

9.7.10 CHANNEL DESCRIPTOR RING SIZE FORPREFETCH – OFFSET 24h

BIT	FUNCTION	TYPE	DESCRIPTION	DEFAULT
12:0	Descriptor size	RW	The number of descriptors available for H/W to prefetch is ranged from 1 to 4096.	0040h
15:13	Reserved	RsvdP	Not support.	000b
28:16	Pre-fetch Descriptor Index	RO	Index value of next descriptor for Prefetch	0000h
31:29	Reserved	RsvdP	Not support.	000b

9.7.11 DOMAIN 0/1/2/3 MAX PAYLOAD SIZE AND READ REQUEST SIZE– OFFSET 28h (Global)

BIT	FUNCTION	TYPE	DESCRIPTION	DEFAULT
2:0	Domain 0 Max Payload Size	RW	000b: 128 bytes 001b: 256 bytes 010b: 512 bytes Other: Reserved	000b
5:3	Domain 0 Read Request Size	RW	000b: 128 bytes 001b: 256 bytes 010b: 512 bytes 011b: 1024 bytes 100b: 2048 bytes 101b: 4096 bytes Other: Reserved	000b
7:6	Reserved	RsvdP	Not support.	00b
10:8	Domain 1 Max Payload Size	RW	000b: 128 bytes 001b: 256 bytes 010b: 512 bytes Other: Reserved	000b
13:11	Domain 1 Read Request Size	RW	000b: 128 bytes 001b: 256 bytes 010b: 512 bytes 011b: 1024 bytes 100b: 2048 bytes 101b: 4096 bytes Other: Reserved	000b
15:14	Reserved	RsvdP	Not support.	00b
18:16	Domain 2 Max Payload Size	RW	000b: 128 bytes 001b: 256 bytes 010b: 512 bytes Other: Reserved	000b
21:19	Domain 2 Read Request Size	RW	000b: 128 bytes 001b: 256 bytes 010b: 512 bytes 011b: 1024 bytes 100b: 2048 bytes 101b: 4096 bytes Other: Reserved	000b
23:22	Reserved	RsvdP	Not support.	00b
26:24	Domain 3 Max Payload Size	RW	000b: 128 bytes 001b: 256 bytes 010b: 512 bytes Other: Reserved	000b
29:27	Domain 3 Read Request Size	RW	000b: 128 bytes 001b: 256 bytes 010b: 512 bytes 011b: 1024 bytes 100b: 2048 bytes 101b: 4096 bytes Other: Reserved	000b
31:30	Reserved	RsvdP	Not support.	00b

9.7.12 DOMAIN 4/5/6/7 MAX PAYLOAD SIZE AND READ REQUEST SIZE – OFFSET 2Ch (Global)

BIT	FUNCTION	TYPE	DESCRIPTION	DEFAULT
2:0	Domain 4 Max Payload Size	RW	000b: 128 bytes 001b: 256 bytes 010b: 512 bytes Other: Reserved	000b
5:3	Domain 4 Read Request Size	RW	000b: 128 bytes 001b: 256 bytes 010b: 512 bytes 011b: 1024 bytes 100b: 2048 bytes 101b: 4096 bytes Other: Reserved	000b
7:6	Reserved	RsvdP	Not support.	00b
10:8	Domain 5 Max Payload Size	RW	000b: 128 bytes 001b: 256 bytes 010b: 512 bytes Other: Reserved	000b
13:11	Domain 5 Read Request Size	RW	000b: 128 bytes 001b: 256 bytes 010b: 512 bytes 011b: 1024 bytes 100b: 2048 bytes 101b: 4096 bytes Other: Reserved	000b
15:14	Reserved	RsvdP	Not support.	00b
18:16	Domain 6 Max Payload Size	RW	000b: 128 bytes 001b: 256 bytes 010b: 512 bytes Other: Reserved	000b
21:19	Domain 6 Read Request Size	RW	000b: 128 bytes 001b: 256 bytes 010b: 512 bytes 011b: 1024 bytes 100b: 2048 bytes 101b: 4096 bytes Other: Reserved	000b
23:22	Reserved	RsvdP	Not support.	00b
26:24	Domain 7 Max Payload Size	RW	000b: 128 bytes 001b: 256 bytes 010b: 512 bytes Other: Reserved	000b
29:27	Domain 7 Read Request Size	RW	000b: 128 bytes 001b: 256 bytes 010b: 512 bytes 011b: 1024 bytes 100b: 2048 bytes 101b: 4096 bytes Other: Reserved	000b
31:30	Reserved	RsvdP	Not support.	00b

9.7.13 DOMAIN 8/9/10/11 MAX PAYLOAD SIZE AND READ REQUEST SIZE – OFFSET 30h (Global)

BIT	FUNCTION	TYPE	DESCRIPTION	DEFAULT
2:0	Domain 8 Max Payload Size	RW	000b: 128 bytes 001b: 256 bytes 010b: 512 bytes Other: Reserved	000b

BIT	FUNCTION	TYPE	DESCRIPTION	DEFAULT
5:3	Domain 8 Read Request Size	RW	000b: 128 bytes 001b: 256 bytes 010b: 512 bytes 011b: 1024 bytes 100b: 2048 bytes 101b: 4096 bytes Other: Reserved	000b
7:6	Reserved	RsvdP	Not support.	00b
10:8	Domain 9 Max Payload Size	RW	000b: 128 bytes 001b: 256 bytes 010b: 512 bytes Other: Reserved	000b
13:11	Domain 9 Read Request Size	RW	000b: 128 bytes 001b: 256 bytes 010b: 512 bytes 011b: 1024 bytes 100b: 2048 bytes 101b: 4096 bytes Other: Reserved	000b
15:14	Reserved	RsvdP	Not support.	00b
18:16	Domain 10 Max Payload Size	RW	000b: 128 bytes 001b: 256 bytes 010b: 512 bytes Other: Reserved	000b
21:19	Domain 10 Read Request Size	RW	000b: 128 bytes 001b: 256 bytes 010b: 512 bytes 011b: 1024 bytes 100b: 2048 bytes 101b: 4096 bytes Other: Reserved	000b
23:22	Reserved	RsvdP	Not support.	00b
26:24	Domain 11 Max Payload Size	RW	000b: 128 bytes 001b: 256 bytes 010b: 512 bytes Other: Reserved	000b
29:27	Domain 11 Read Request Size	RW	000b: 128 bytes 001b: 256 bytes 010b: 512 bytes 011b: 1024 bytes 100b: 2048 bytes 101b: 4096 bytes Other: Reserved	000b
31:30	Reserved	RsvdP	Not support.	00b

9.7.14 DOMAIN 0/1/2/3 BUS NUMBER – OFFSET 34h (Global)

BIT	FUNCTION	TYPE	DESCRIPTION	DEFAULT
7:0	Domain 0 Bus Number	RW	Indicates Bus Number for Request ID.	00h
15:8	Domain 1 Bus Number	RW	Indicates Bus Number for Request ID.	00h
23:16	Domain 2 Bus Number	RW	Indicates Bus Number for Request ID.	00h
31:24	Domain 3 Bus Number	RW	Indicates Bus Number for Request ID.	00h

9.7.15 DOMAIN 4/5/6/7 BUS NUMBER – OFFSET 38h (Global)

BIT	FUNCTION	TYPE	DESCRIPTION	DEFAULT
7:0	Domain 4 Bus Number	RW	Indicates Bus Number for Request ID.	00h

BIT	FUNCTION	TYPE	DESCRIPTION	DEFAULT
8:15	Domain 5 Bus Number	RW	Indicates Bus Number for Request ID.	00h
23:16	Domain 6 Bus Number	RW	Indicates Bus Number for Request ID.	00h
31:24	Domain 7 Bus Number	RW	Indicates Bus Number for Request ID.	00h

9.7.16 DOMAIN 8/9/10/11 BUS NUMBER – OFFSET 3Ch (Global)

BIT	FUNCTION	TYPE	DESCRIPTION	DEFAULT
7:0	Domain 8 Bus Number	RW	Indicates Bus Number for Request ID.	00h
8:15	Domain 9 Bus Number	RW	Indicates Bus Number for Request ID.	00h
23:16	Domain 10 Bus Number	RW	Indicates Bus Number for Request ID.	00h
31:24	Domain 11 Bus Number	RW	Indicates Bus Number for Request ID.	00h

9.7.17 USER DEFINED ATTRIBUTES FOR DMA OPERATION – OFFSET 40h

BIT	FUNCTION	TYPE	DESCRIPTION	DEFAULT
9:0	Max. Read Request Size Value	RW	Used to set user-defined max. read request size. 020h: 128 Bytes 040h: 256 Bytes 080h: 512 Bytes 100h: 1024 Bytes Others: Reserved	000h
10	User-Defined Max Read Request Size Enable	RW	Enable User defines MAX read requester size.	0
31:11	Reserved	RsvdP	Not support.	0000_0h

9.7.18 CHANNEL UNCORRECTABLE EEEOR STATUS– OFFSET 44h

BIT	FUNCTION	TYPE	DESCRIPTION	EEPROM/ I2C-SMBUS	DEFAULT
0	Training Error Status	RW1C	When set, indicates that the Training Error event has occurred.	Yes	0
3:1	Reserved	RsvdP	Not support.	No	000b
4	Data Link Protocol Error Status	RW1C	When set, indicates that the Data Link Protocol Error event has occurred.	Yes	0
5	Surprise Down Error Status	RW1C	When set, indicates that the Surprise Down Error event has occurred.	Yes	0
11:6	Reserved	RsvdP	Not support.	No	0-0b
12	Poisoned TLP Status	RW1C	When set, indicates that a Poisoned TLP has been received or generated.	Yes	0
13	Flow Control Protocol Error Status	RW1C	When set, indicates that the Flow Control Protocol Error event has occurred.	Yes	0
14	Completion Timeout Status	RW1C	When set, indicates that the Completion Timeout event has occurred.	Yes	0
15	Completer Abort Status	RW1C	When set, indicates that the Completer Abort event has occurred.	Yes	0
16	Unexpected Completion Status	RW1C	When set, indicates that the Unexpected Completion event has occurred.	Yes	0
17	Receiver Overflow Status	RW1C	When set, indicates that the Receiver Overflow event has occurred.	Yes	0
18	Malformed TLP Status	RW1C	When set, indicates that a Malformed TLP has been received.	Yes	0
19	ECRC Error Status	RW1C	When set, indicates that an ECRC Error has been detected.	Yes	0
20	Unsupported Request Error Status	RW1C	When set, indicates that an Unsupported Request event has occurred.	Yes	0

BIT	FUNCTION	TYPE	DESCRIPTION	EEPROM/ I2C-SMBUS	DEFAULT
21	ACS Violation Status	RW1C	When set, indicates that an ACS Violation event has occurred.	Yes	0
22	Internal Error Status	RW1C	When set, indicates that an Internal Error has occurred.	Yes	0
23	MC Blocked TLP Status	RW1C	When set, indicates that an MC Blocked TLP event has occurred.	Yes	0
24	AtomicOp Egress Blocked Status	RW1C	When set, indicates that an AtomicOp Egress Blocked event has occurred.	Yes	0
25	Descriptor Error	RW1C	When set, indicates an Uncorrectable Error happening in descriptor	Yes	0
26	Data Buffer Error	RW1C	When set, indicates an Uncorrectable Error happening in moving data into DMA buffer.	Yes	0
31:27	Reserved	RsvdP	Not support.	No	0000_000b

9.7.19 DMA READ THRESHOLD CONTROL – OFFSET 5Ch

BIT	FUNCTION	TYPE	DESCRIPTION	DEFAULT
4:0	Desc_Current_Arbitrator_Sts	RO	It will indicate descriptor current arbiter status.	0_0001b
5	Desc_Arbitrator_Reset	RW	When set, it will reset descriptor arbiter.	0
7:6	Reserved	RsvdP	Not support.	00b
12:8	DMA_Current_Arbitrator_Sts	RO	It will indicate DMA current arbiter status.	0_0001b
13	DMA_Arbitrator_Reset	RW	When set, it will reset DMA arbiter.	0
15:14	Reserved	RsvdP	Not support.	00b
24:16	Threshold Value	RW	When threshold control disable is off, the next DMA read won't be issued until the threshold value is met. The default value is equivalent to 512 bytes.	80h
25	Threshold Control Disable	RW	When set, DMA read is issued without waiting threshold limit being reached. The default is to disable threshold control.	1b
31:26	Reserved	RsvdP	Not support.	0000_0b

9.7.20 DMA HARDWARE CONTROL – OFFSET 88h (Global)

BIT	FUNCTION	TYPE	DESCRIPTION	DEFAULT
9:0	DNOC Arbit Delay Time	RW	Used to set DNOC Arbit delay time.	0_00h
14:10	Reserved	RsvdP	Not support	0
15	DNOC Arbit Delay Time Enable	RW	When set, it will enable dnoc arbit delay time function for DMA packets The time unit is in 2ns.	0
22:16	Back-to-Back Packet gap time	RW	For back-to-back DMA packets, a programmable gap time between continuous packets can be inserted. The time unit is in 2ns.	00h
23	Back-to-Back Packet gap Time Enable	RW	When set, it will enable back-to-back packet gap time.	0
24	ECRC Check Enable override	RW	When clear, it can override ECRC check enable bit defined in AER control register from 1 to 0 for DMA packet only	1
25	Arbitration option	RW	This option bit controls the request/grant protocol between central arbiter and DMA engine. By default, the DMA request is not asserted until the the last grant released.	1
26	MSI regeneration enable	RW	The MSI event will be regenerated once not getting service after a time-out period. When disabled, the MSI will be issued only one time.	1
27	Internal CAM hit Error Enable	RW	When set, it will enable CAM hit error function.	1
31:28	Reserved	RsvdP	Not support	0000b

9.7.21 DMA HARDWARE STATUS – OFFSET 8Ch (Global)

BIT	FUNCTION	TYPE	DESCRIPTION	DEFAULT
0	ECRC Check Enable	RO	It is a mirror-bit of ECRC Check Enable status in AER control register	0
1	ECRC Generation Enable	RO	It is a mirror-bit of ECRC Generation Enable status in AER control register	0
31:2	Reserved	RsvdP	Not support	0-0b

10 POWER SEQUENCE

As long as PERST# is asserted, all PCI Express functions are held in reset. The main supplies ramp up to their specified levels (0.95V/1.8V). Sometime during this stabilization time, the REFCLK starts and stabilizes. After elapsing some time (i.e. 100 us) for the power and clock to become stable, PERST# is deasserted high and the PCI Express functions can start up.

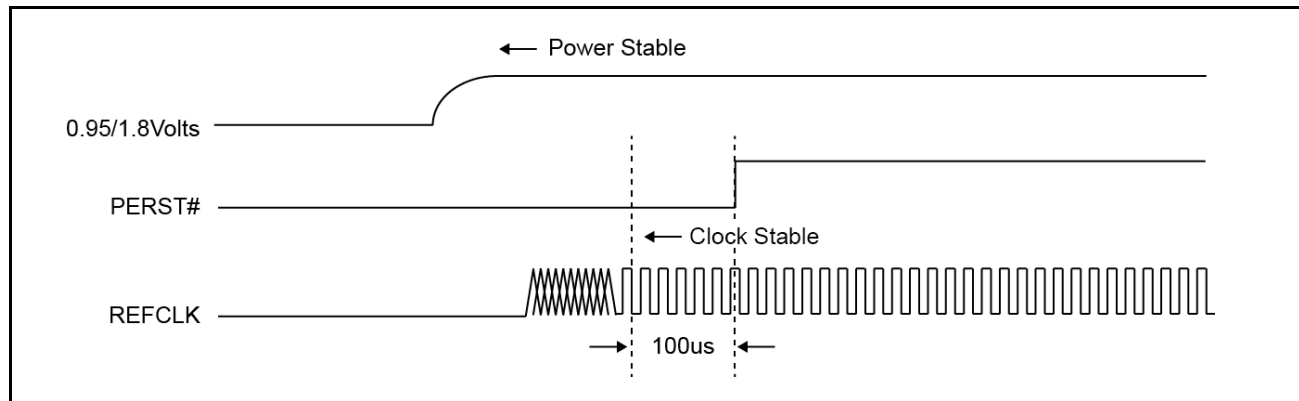

Figure 10-1 Initial Power-Up Sequence

11 IEEE 1149.1 COMPATIBLE JTAG CONTROLLER

An IEEE 1149.1 compatible Test Access Port (TAP) controller and associated TAP pins are provided to support boundary scan in PI7C9X3G816GP for board-level continuity test and diagnostics. The TAP pins assigned are TCK, TDI, TDO, TMS and TRST_L. All digital input, output, input/output pins except TAP pins and SERDES pins are tested.

11.1 INSTRUCTION REGISTER

The IEEE 1149.1 Test Logic consists of a TAP controller, an instruction register, and a group of test data registers including Bypass and Boundary Scan registers. The TAP controller is a synchronous 16-state machine driven by the Test Clock (TCK) and the Test Mode Select (TMS) pins. An independent power on reset circuit is provided to ensure the machine is in TEST_LOGIC_RESET state at power-up.

PI7C9X3G816GP implements a 5-bit Instruction register to control the operation of the JTAG logic. The defined instruction codes are shown in the following table. Those bit combinations that are not listed are equivalent to the BYPASS (1111) instruction.

Table 11-1 Instruction Register Codes

Instruction	Operation Code (binary)	Register Selected	Operation
EXTEST	0000	Boundary Scan	Drives / receives off-chip test data
SAMPLE	0010	Boundary Scan	Samples inputs
EXTEST_PULSE	0100	Boundary Scan	Drives/receives off-chip test data for TX/RX pins
EXTEST_TRAIN	0101	Boundary Scan	Drives/receives off-chip test data for TX/RX pins
SCAN_TEST	1010	Internal	Private instruction
IDCODE	0001	Device ID	Accesses the Device ID register, to read manufacturer ID, part number, and version number
RX_LEVEL	1011	Internal	Private instruction
NOC_BIST	0111	Internal	Private instruction
MBIST	1101	Internal	Private instruction
BYPASS	1111	Bypass	Selected Bypass Register

11.2 BYPASS REGISTER

The required bypass register (one-bit shift register) provides the shortest path between TDI and TDO when a bypass instruction is in effect. This allows rapid movement of test data to and from other components on the board. This path can be selected when no test operation is being performed on the PI7C9X3G816GP.

11.3 DEVICE ID REGISTER

This register identifies Diodes as the manufacturer of the device and details the part number and revision number for the device.

Table 11-2 JTAG Device ID Register

Bit	Type	Value	Description
31-28	RO	0001	Version number
27-12	RO	0001011000010110	Last 4 digits (hex) of the die part number
11-1	RO	01000111111	Diodes identifier assigned by JEDEC
0	RO	1	Fixed bit equal to 1'b1

11.4 BOUNDARY SCAN REGISTER

The boundary scan register has a set of serial shift-register cells. A chain of boundary scan cells is formed by connected the internal signal of the PI7C9X3G816GP package pins. The VDD, VSS, and JTAG pins are not in the boundary scan chain. The input to the shift register is TDI and the output from the shift register is TDO. There are 4 different types of boundary scan cells, based on the function of each signal pin.

The boundary scan register cells are dedicated logic and do not have any system function. Data may be loaded into the boundary scan register master cells from the device input pins and output pin-drivers in parallel by the mandatory SAMPLE and EXTEST instructions. Parallel loading takes place on the rising edge of TCK.

11.5 JTAG BOUNDARY SCAN REGISTER ORDER

Table 11-3 JTAG Boundary Scan Register Definition

Boundary Scan Register Number	Pin Name	Ball Location	Type	Tri-state Control Cell
0			internal	
1			internal	
2	SDA_I2C	J18	bidir	3
3			control	
4	SCL_I2C	K18	bidir	5
5			control	
6			internal	
7			internal	
8	PERST_L	F18	input	
9			internal	
10			internal	
11	PDC_L[7]	N9	bidir	12
12			control	
13	PDC_L[6]	P8	bidir	14
14			control	
15			internal	
16			internal	
17	PDC_L[5]	P9	bidir	18
18			control	
19			internal	
20			internal	
21	PDC_L[4]	R8	bidir	22
22			control	
23	PDC_L[3]	R9	bidir	24
24			control	
25	PDC_L[2]	T8	bidir	26
26			control	
27	PDC_L[1]	U8	bidir	28
28			control	
29	PDC_L[0]	V8	bidir	30
30			control	
31	PERN[3]	A13	observe_only	
32	PERP[3]	B13	observe_only	
33	PETP[3]	E13	output2	
34	PERN[2]	A14	observe_only	
35	PERP[2]	B14	observe_only	
36	PETP[2]	E14	output2	
37	PERN[1]	A15	observe_only	
38	PERP[1]	B15	observe_only	
39	PETP[1]	E15	output2	
40	PERN[0]	A16	observe_only	
41	PERP[0]	B16	observe_only	
42	PETP[0]	E16	output2	
43	PERN[7]	A9	observe_only	

Boundary Scan Register Number	Pin Name	Ball Location	Type	Tri-state Control Cell
44	PERP[7]	B9	observe_only	
45	PETP[7]	E9	output2	
46	PERN[6]	A10	observe_only	
47	PERP[6]	B10	observe_only	
48	PETP[6]	E10	output2	
49	PERN[5]	A11	observe_only	
50	PERP[5]	B11	observe_only	
51	PETP[5]	E11	output2	
52	PERN[4]	A12	observe_only	
53	PERP[4]	B12	observe_only	
54	PETP[4]	E12	output2	
55	FATAL_ERR_L	K7	bidir	56
56			control	
57	INTA_L	K6	bidir	58
58			control	
59	TEST	C4	bidir	60
60			control	
61	GPIO[31]	A1	bidir	62
62			control	
63	GPIO[30]	A2	bidir	64
64			control	
65	GPIO[29]	B1	bidir	66
66			control	
67			internal	
68			internal	
69	SMBUS_EN_L	U17	bidir	70
70			control	
71	GPIO[28]	B2	bidir	72
72			control	
73	GPIO[27]	C1	bidir	74
74			control	
75	I2C_ADDR[0]	U18	bidir	76
76			control	
77	GPIO[26]	D1	bidir	78
78			control	
79	I2C_ADDR[1]	V18	bidir	80
80			control	
81	GPIO[25]	E1	bidir	82
82			control	
83	GPIO[24]	F1	bidir	84
84			control	
85	I2C_ADDR[2]	V17	bidir	86
86			control	
87	GPIO[23]	K2	bidir	88
88			control	
89			internal	
90			internal	
91	GPIO[22]	K3	bidir	92
92			control	
93	GPIO[21]	K4	bidir	94
94			control	
95	CLKBUF_INPUT_SEL	L16	bidir	96
96			control	
97	GPIO[20]	K5	bidir	98
98			control	
99	GPIO[19]	K17	bidir	100
100			control	
101			internal	
102			internal	
103	GPIO[18]	M15	bidir	104
104			control	
105	GPIO[17]	L13	bidir	106
106			control	

Boundary Scan Register Number	Pin Name	Ball Location	Type	Tri-state Control Cell
107	GPIO[16]	L14	bidir	108
108			control	
109	GPIO[15]	L15	bidir	110
110			control	
111	GPIO[14]	L17	bidir	112
112			control	
113	GPIO[13]	L18	bidir	114
114			control	
115	GPIO[12]	M18	bidir	116
116			control	
117	GPIO[11]	N18	bidir	118
118			control	
119	GPIO[10]	P18	bidir	120
120			control	
121	GPIO[9]	R18	bidir	122
122			control	
123	GPIO[8]	T18	bidir	124
124			control	
125	GPIO[7]	T17	bidir	126
126			control	
127	GPIO[6]	E18	bidir	128
128			control	
129	GPIO[5]	D17	bidir	130
130			control	
131	GPIO[3]	C17	bidir	132
132			control	
133	GPIO[4]	D18	bidir	134
134			control	
135	GPIO[2]	C18	bidir	136
136			control	
137	GPIO[1]	B18	bidir	138
138			control	
139	GPIO[0]	A17	bidir	140
140			control	
141	PERN[11]	V12	observe_only	
142	PERP[11]	U12	observe_only	
143	PETP[11]	P13	output2	
144	PERN[10]	V11	observe_only	
145	PERP[10]	U11	observe_only	
146	PETP[10]	P12	output2	
147	PERN[9]	V10	observe_only	
148	PERP[9]	U10	observe_only	
149	PETP[9]	P11	output2	
150	PERN[8]	V9	observe_only	
151	PERP[8]	U9	observe_only	
152	PETP[8]	P10	output2	
153	PERN[15]	V16	observe_only	
154	PERP[15]	U16	observe_only	
155	PETP[15]	P17	output2	
156	PERN[14]	V15	observe_only	
157	PERP[14]	U15	observe_only	
158	PETP[14]	P16	output2	
159	PERN[13]	V14	observe_only	
160	PERP[13]	U14	observe_only	
161	PETP[13]	P15	output2	
162	PERN[12]	V13	observe_only	
163	PERP[12]	U13	observe_only	
164	PETP[12]	P14	output2	
165	PORTCFG[2]	C7	input	
166	SHCL_I2C	M10	bidir	167
167			control	
168	PORTCFG[1]	C12	input	
169	SHPCINT_L	M12	bidir	170

Boundary Scan Register Number	Pin Name	Ball Location	Type	Tri-state Control Cell
170			control	
171	PORTCFG[0]	C15	input	
172	SHDA_I2C	M11	bidir	173
173			control	
174			internal	
175			internal	
176	EECS_L	H17	bidir	177
177			control	
178	EECK	H16	bidir	179
179			control	
180	EEDO	H18	bidir	181
181			control	
182	CKMODE	F17	bidir	183
183			control	
184	EEDI	J16	bidir	185
185			control	
186	LNKSTS[7]	H15	bidir	187
187			control	
188	LNKSTS[6]	H14	bidir	189
189			control	
190	LNKSTS[5]	H13	bidir	191
191			control	
192	LNKSTS[4]	H12	bidir	193
193			control	
194	LNKSTS[3]	G13	bidir	195
195			control	
196	LNKSTS[2]	G16	bidir	197
197			control	
198	LNKSTS[1]	G17	bidir	199
199			control	
200	LNKSTS[0]	G18	bidir	201
201			control	
202			internal	
203			internal	

12 ELECTRICAL AND TIMING SPECIFICATIONS

12.1 ABSOLUTE MAXIMUM RATINGS

Table 12-1 Absolute Maximum Ratings

(Above which the useful life may be impaired. For user guidelines, not tested.)

Item	Absolute Max. Rating
Storage Temperature	-65°C to 150°C
Junction Temperature, T _j	125°C
Digital core and analog supply voltage to ground potential (VDDC and AVDD)	VDDC +10%
Digital I/O and analog high supply voltage to ground potential (VDDR and AVDDH)	VDDR + 10%
DC input voltage for Digital I/O signals	2.75V
ESD Rating	
Human Body Model (JEDEC Class 2)	HBM 2KV
Charge Device Model (JEDEC Class 3)	CDM 500V

Note:

Stresses greater than those listed under MAXIMUM RATINGS may cause permanent damage to the device. This is a stress rating only and functional operation of the device at these or any conditions above those indicated in the operational sections of this specification is not implied. Exposure to absolute maximum rating conditions for extended periods of time may affect reliability.

12.2 DC ELECTRICAL CHARACTERISTICS

Table 12-2 DC Electrical Characteristics

Symbol	Description	Min.	Typ.	Max.	Unit
VDDC ²	Digital Core Power	0.90	0.95	0.99	V
C_VDDR ²	Referenc Clock Power	0.90	0.95	0.99	
VDDR ³	Digital I/O Power	1.71	1.8	1.89	
C_VDDR ³	Reference Clock Power	1.71	1.8	1.89	
VP ²	PCI Express Analog Power	0.90	0.95	0.99	
VPH ²	PCI Express Analog High Voltage Power	1.71	1.8	1.89	
V _{IH}	Input High Voltage	1.17		1.98	
V _{IL}	Input Low Voltage	-0.3		0.63	
V _{OH}	Output High Voltage	1.35			
V _{OL}	Output Low Voltage			0.45	
R _{PU}	Pull-up Resistor	54K	80K	120K	Ω
R _{PD}	Pull-down Resistor	55K	95K	176K	
RST# _{Slew} ¹	PERST_L Slew Rate	50			mV/ns

Note:

- The min. value for PERST_L Slew Rate is 50 mV/ns, which translates to the requirement that the time for PERST_L from 0V to 2.5V should be less than 50 ns.
- Peak to peak AC noise < 5% of DC level.
- Peak to peak AC noise < 3% of DC level.

12.3 PCIE REFERENCE CLOCK REQUIREMENTS

Table 12-1 specifies the voltage/timing requirements and operating characteristics for PCIe PHY (REFCLKP/N[1:0] and REFCLKP/N[1:0]).

Table 12-3 PCIe Reference Clock Requirement

Application	Reference Clock Jitter and Swing Requirements
PCIe 1.1 – 2.5 GT/s	Refer to the PCI Express 3.0 Card Electromechanical specification.
PCIe 2.1 – 5.0 GT/s	Refer to the PCI Express 3.1 base specification.
PCIe 3.1 – 8.0 GT/s	Refer to the PCI Express 3.1 base specification.

12.4 INTEGRATED CLOCK BUFFER SPECIFICATIONS

The built-in Integrated Reference Clock Buffer of the PI7C9X3G816GP supports eight reference clock outputs. Table 12-4 and Table 12-5 specify the voltage/timing requirements and operating characteristics for internal clock buffer input (REFCLKIP/N and REFCLKIP/N) and outputs (REFCLKOP/N[7:0] and REFCLKOP/N[7:0]).

Table 12-4 Integrated Clock Buffer Input Electrical Characteristics

Symbol	Description	Min	Typ	Max	Unit
V _{IHDIF}	Input High Voltage-DIF_IN (Single-ended)	600	800	1150	mV
V _{ILDIF}	Input Low Voltage-DIF_IN (Single-ended)	V _{SS} - 300	0	300	mV
V _{COM}	Input Common Mode Voltage-DIF_IN	300		725	mV
V _{SWING}	Input Amplitude Peak-to-Peak (V _{IHDIF} - V _{ILDIF})	300		1450	mV
I _{IN}	Input Leakage Current	-5	0.01	5	uA
D _{TIN}	Input Duty Cycle	45		55	%
J _{DIFIN}	Input Jitter – Cycle to Cycle	0		150	ps
F _{TIN}	Input Frequency		100		MHz
V _{IL(ASIC)}	Low-level input voltage	0			V
V _{IH(ASIC)}	High-level input voltage			1	V
T _R , T _F	Rise/Fall time of input clock			0.1	RCUI ¹

Note¹: RCUI refers to the reference clock period.

Table 12-5 Integrated Clock Buffer Output Electrical Characteristics

Symbol	Description	Min	Typ	Max	Unit	
T _R	Output Rise Time (20% to 80%)	100	200	500	ps	
T _F	Output Fall Time (80% to 20%)	100	200	500	ps	
V _{HIGH}	Voltage High	Statistical measurement on single-ended signal using oscilloscope math function (Scope averaging on)	660	774	850	mV
V _{LOW}	Voltage Low		-150	18	150	mV
V _{MAX}	Max Voltage	Measurement on single ended signal using absolute value (Scope averaging off)		821	1150	mV
V _{MIN}	Min Voltage		-300	-15		mV
V _{SWING}	Voltage Swing (Scope averaging off)	300	1536		mV	
V _{CROSS_ABS}	Absolute crossing voltage (Scope averaging off)	250	414	550	mV	
ΔV _{CROSS}	Variance crossing voltage (Scope averaging off)		13	140	mV	
T _{PCD}	Duty Cycle Distortion (measured differentially)	-3	0	3	%	
T _{PD}	Skew, Input to Output	1000	3600	4500	ps	
T _{JCC}	Additive Jitter, Cycle to Cycle		0.1	25	ps (p-p)	
T _{JPHG1}	Additive Phase Jitter for PCIe GEN1		0.6	5	ps (rms)	
T _{JPHG2}	Additive Phase Jitter for PCIe GEN2 Low Band 10 kHz < f < 1.5 MHz		0.1	0.3	ps (rms)	
T _{JPHG2}	Additive Phase Jitter for PCIe GEN2 High Band 1.5 MHz < f < Nyquist (50 MHz)		0.05	0.1	ps (rms)	
T _{JPHG3}	Additive Phase Jitter for PCIe GEN3 (PLL BW of 2 ~ 4 MHz, CDR = 10 MHz)		0.05	0.1	ps (rms)	

12.5 COMMON TRANSMITTER PARAMETERS

The following table defines the parameters for transmitters that are common among all three data rates. Parameters are defined separately for 2.5 GT/s, 5.0 GT/s and 8.0 GT/s implementations.

Table 12-6 Transmitter Specifications

Symbol	Parameter	2.5 GT/s	5.0 GT/s	8.0 GT/s	Units	Comments
UI	Unit Interval	399.88 (min) 400.12 (max)	199.94 (min) 200.06 (max)	124.9625 (min) 125.0375 (max)	ps	The specified UI is equivalent to a tolerance of ±300 ppm for each Refclk source. Period does not account for SSC induced variations. See Note 1.
BW _{TX-PLL}	Tx PLL BW for 2.5 GT/s	22 (max) 1.5 (min)	Not specified	Not specified	MHz	See Note 6.
BW _{TX-PKG-PLL1}	Tx PLL	Not specified	16 (max)	4 (max)	MHz	Second order PLL jitter transfer

Symbol	Parameter	2.5 GT/s	5.0 GT/s	8.0 GT/s	Units	Comments
	bandwidth corresponding to $PKG_{TX-PLL1}$		8 (min)	2 (min)		bounding function. See Note 6.
$BW_{TX-PKG-PLL2}$	Tx PLL bandwidth corresponding to $PKG_{TX-PLL2}$	Not specified	16 (max) 5 (min)	5 (max) 2 (min)	MHz	Second order PLL jitter transfer bounding function. See Note 6.
$PKG_{TX-PLL1}$	Tx PLL peaking	Not specified	3.0 (max)	2.0 (Max)	dB	PLL BW = 8 MHz (min) @ 5.0 GT/s or BW = 4 MHz (max) @ 8.0 GT/s. See Note 6 and 8.
$PKG_{TX-PLL2}$	Tx PLL peaking	Not specified	1.0 (max)	1.0 (Max)	dB	PLL BW = 5 MHz (min) @ 5.0 GT/s or BW = 5 MHz (max) @ 8.0 GT/s. See Note 8.
$V_{TX-DIFF-PP}$	Differential p-p Tx voltage swing	0.8 (min) 1.2 (max)	0.8 (min) 1.2 (max)	See Table 12-7	VPP	As measured with compliance test load. Defined as $2* V_{TXD+}-V_{TXD-} $.
$V_{TX-DIFF-PP-LOW}$	Low power differential p-p Tx voltage swing	0.4 (min) 1.2 (max)	0.4 (min) 1.2 (max)	See Table 12-7	VPP	As measured with compliance test load. Defined as $2* V_{TXD+}-V_{TXD-} $. See Note 9.
$V_{TX-DE-RATIO-3.5dB}$	Tx de-emphasis level ratio	3.0 (min) 4.0 (max)	3.0 (min) 4.0 (max)	See Table 12-7	dB	See PCI Express Base Specification Revision 3.1, Section 4.3.3.3 and Note 11.
$\sqrt{V_{TX-DE-RATIO-6dB}}$	Tx de-emphasis level	N/A	5.5 (min) 6.5 (max)	See Table 12-7	dB	See PCI Express Base Specification Revision 3.1, Section 4.3.3.3 and Note 11.
$T_{MIN-PULSE}$	Instantaneous lone pulse width	Not specified	0.9 (min)	See Table 12-7	UI	Measured relative to rising/falling pulse. See Note 2, 10 and PCI Express Base Specification Revision 3.1, Figure 4-38.
T_{TX-EYE}	Transmitter Eye including all jitter sources	0.75 (min)	0.75 (min)	See Table 12-7	UI	Does not include SSC or Refclk jitter. Includes Rj at 10^{12} . Note that 2.5 GT/s and 5.0 GT/s use different jitter determination methods.
$T_{TX-EYE-MEDIAN-10-MAX-JITTER}$	Maximum time between the jitter median and max deviation from the median	0.125 (max)	Not specified	Not specified	UI	Measured differentially at zero crossing points after applying the 2.5 GT/s clock recovery function. See Note 2.
$T_{TX-HF-DJ-DD}$	Tx deterministic jitter > 1.5 MHz	Not specified	0.15 (max)	See Table 12-7	UI	Deterministic jitter only. See Notes 2 and 10.
$T_{TX-LF-RMS}$	Tx RMS jitter < 1.5 MHz	Not specified	3.0	See Table 12-7	Ps RMS	Total energy measured over a 10 kHz - 1.5 MHz range.
$T_{RF-MISMATCH}$	Tx rise/fall mismatch	Not specified	0.1 (max)	Not specified	UI	Measured from 20% to 80% differentially. See Note 2.
$RL_{TX-DIFF}$	Tx package plus Si differential return loss	10 (min)	10 (min) for 0.05 - 1.25 GHz 8 (min) for > 1.25 - 2.5 GHz	10 (min) for 0.05 - 1.25 GHz 8 (min) for > 1.25 - 2.5 GHz 4 (min) for > 2.5 - 4 GHz	dB	For details refer to PCI Express Base Specification Revision 3.1, Figure 4-56.
RL_{TX-CM}	Tx package plus Si common mode return loss	6 (min) for 0.05 - 2.5 GHz	6 (min) for 0.05 - 2.5 GHz	6 (min) for 0.05 - 2.5GHz 3 (min) for 2.5 GHz	dB	For details refer to PCI Express Base Specification Revision 3.1, Figure 4-57.
$Z_{TX-DIFF-DC}$	DC differential Tx impedance	80 (min) 120 (max)	120 (max)	120 (max)	Ω	Low impedance defined during signaling. Parameter is captured for 5.0 GHz by $RL_{TX-DIFF}$. The (min) value is bounded by $RL_{TX-DIFF}$ for 5.0 GT/s and 8.0 GT/s.
$V_{TX-CM-AC-PP}$	Tx AC peak-peak common mode voltage (5.0 GT/s)	Not specified	150 (max)	150 (max)	mVPP	At 8.0 GT/s, no more than 50mVPP in 0.03-500 MHz range. At 5.0GT/s no more than 100mVPP in 0.03-500 MHz range. See Notes 5 and 12.
$V_{TX-CM-AC-P}$	Tx AC peak common mode voltage (2.5 GT/s)	20	Not specified	Not specified	mV	See Note 5.
$I_{TX-SHORT}$	Transmitter short-circuit current	90 (max)	90 (max)	90 (max)	mA	The total single-ended current a transmitter can supply when shorted

Symbol	Parameter	2.5 GT/s	5.0 GT/s	8.0 GT/s	Units	Comments
	limit					to ground. See Note 13.
$V_{TX-DC-CM}$	Transmitter DC common-mode voltage	0 (min) 3.6 (max)	0 (min) 3.6 (max)	0 (min) 3.6 (max)	V	The allowed DC common-mode voltage at a transmitter pin under any conditions. See Note 13.
$V_{TX-CM-DC-ACTIVE-IDLE-DELTA}$	Absolute Delta of DC Common Mode Voltage during L0 and Electrical Idle	0 (min) 100 (max)	0 (min) 100 (max)	0 (min) 100 (max)	mV	$ V_{TX-CM-DC} [during L0] - V_{TX-CM-Idle-DC} [during Electrical Idle] \leq 100mV$ $V_{TX-CM-DC} = DC_{(avg)} \text{ of } V_{TX-D+} + V_{TX-D-} /2$ $V_{TX-CM-Idle-DC} = DC_{(avg)} \text{ of } V_{TX-D+} + V_{TX-D-} /2 [Electrical Idle]$
$V_{TX-CM-DC-LINE-DELTA}$	Absolute Delta of DC Common Mode Voltage between D+ and D-	0 (min) 25 (max)	0 (min) 25 (max)	0 (min) 25 (max)	mV	$ V_{TX-CM-DC-D+} [during L0] - V_{TX-CM-DC-D-} [during L0] \leq 25mV$ $V_{TX-CM-DC-D+} = DC_{(avg)} \text{ of } V_{TX-D+} [during L0]$ $V_{TX-CM-DC-D-} = DC_{(avg)} \text{ of } V_{TX-D-} [during L0].$
$V_{TX-IDLE-DIFF-AC-p}$	Electrical Idle Differential Peak Output Voltage	0 (min) 20 (max)	0 (min) 20 (max)	0 (min) 20 (max)	mV	$V_{TX-IDLE-DIFF-AC-p} = V_{TX-Idle-D+} - V_{TX-Idle-D-} \leq 20mV$. Voltage must be band pass filtered to remove any DC component and HF noise. The bandpass is constructed from two first-order filters, the high pass and low pass 3dB bandwidths are 10 kHz and 1.25 GHz respectively.
$V_{TX-IDLE-DIFF-DC}$	DC Electrical Idle Differential Output Voltage	Not specified	0 (min) 5 (max)	0 (min) 5 (max)	mV	$V_{TX-IDLE-DIFF-DC} = V_{TX-Idle-D+} - V_{TX-Idle-D-} \leq 5mV$. Voltage must be low pass filtered to remove any AC component. The low pass filter is first-order with a 3dB bandwidth of 10 kHz.
$V_{TX-RCV-DETECT}$	The amount of voltage change allowed during Receiver Detection	600 (max)	600 (max)	600 (max)	mV	The total amount of voltage change in a positive direction that a Transmitter can apply to sense whether a low impedance Receiver is present. Note: Receivers display substantially different impedance for $V_{IN} < 0$ vs $V_{IN} > 0$. See PCI Express Base Specification Revision 3.1, Table 4-24 for detail
$T_{TX-IDLE-MIN}$	Minimum time spent in Electrical Idle	20 (min)	20 (min)	20 (min)	ns	Minimum time a Transmitter must be in Electrical Idle.
$T_{TX-IDLE-SET-TO-IDLE}$	Maximum time to transition to a valid Electrical Idle after sending an EIOS	8 (max)	8 (max)	8 (max)	ns	After sending the required number of EIOSs, the Transmitter must meet all Electrical Idle specifications within this time. This is measured from the end of the last UI of the last EIOS to the Transmitter in Electrical Idle.
$T_{TX-IDLE-TO-DIFF-DATA}$	Maximum time to transition to valid diff signaling after leaving Electrical Idle	8 (max)	8 (max)	8 (max)	ns	Maximum time to transition to valid diff signaling after leaving Electrical Idle. This is considered a debounce time to the Tx.
$T_{CROSSLINK}$	Crosslink random timeout	1.0 (max)	1.0 (max)	1.0 (max)	ms	This random timeout helps resolve potential conflicts in the crosslink configuration.
$L_{TX-SKEW}$	Lane-to-Lane Output Skew	500 ps + 2 UI (max)	500 ps + 4 UI (max)	500 ps + 6 UI	ps	Between any two Lanes within a single Transmitter.
C_{TX}	AC Coupling Capacitor	75 (min) 265 (max)	75 (min) 265 (max)	176 (min) 265 (max)	nF	All Transmitters shall be AC coupled. The AC coupling is required wither within the media or within the transmitting component itself. See Note 14.

Note:

- SSC permits a +0, -5000ppm modulation of the clock frequency at a modulation rate not to exceed 33 kHz.

- Measurements at 5.0 GT/s require an oscilloscope with a bandwidth of ≥ 12.5 GHz, or equivalent, while measurements made at 2.5 GT/s require a scope with a least 6.2 GHz bandwidth. Measurement at 5.0 GT/s must deconvolve effects of compliance test board to yield an effective measurement at Tx pins. 2.5 GT/s may be measured within 200 mils of Tx device's pins, although deconvolution is recommended. For measurement setup details, refer PCI Express Base Specification Revision 3.1, Figure 4-32 to and Figure 4-33. At least 10^6 UI of data must be acquired.
- Transmitter jitter is measured by driving the Transmitter under test with a low jitter "ideal" clock and connecting the DUT to a reference load.
- Transmitter raw jitter data must be convolved with a filtering function that represents the worst case CDR tracking BW. 2.5 GT/s and 5.0 GT/s use different filter functions that are defined in PCI Express Base Specification Revision 3.1, Figure 4-49. After the convolution process has been applied, the center of the resulting eye must be determined and used as a reference point for obtaining eye voltage and margins.
- $V_{TX-AC-CM-PP}$ and $V_{TX-AC-CM-P}$ are defined in PCI Express Base Specification Revision 3.1, Section 4.3.3.2. Measurement is made over at least 10^6 UI.
- The Tx PLL Bandwidth must lie between the min and max ranges given in the above table. PLL peaking must lie below the value listed above. Note: the PLL B/W extends from zero up to the values(s) specified in the above table.
- Measurements are made for both common mode and differential return loss. The DUT must be powered up and DC isolated, and its data+/data-output must be in the low-Z state at a static value.
- A single combination of PLL BW and peaking is specified for 2.5 GT/s implementations. For 5.0 GT/s, two combinations of PLL BW and peaking are specified to permit designers to make a tradeoff between the two parameters. If the PLL's min BW is ≥ 8 MHz, then up to 3.0 dB of peaking is permitted. If the PLL's min BW is relaxed to ≥ 5.0 MHz, then a tighter peaking value of 1.0 dB must be met. In both cases, the max PLL BW is 16 MHz.
- Reduced swing output, defined by $V_{TX-DIFF-PP-LOW}$ must be implemented as shown in PCI Express Base Specification Revision 3.1, Figure 4-37 with no de-emphasis.
- For 5.0 GT/s, de-emphasis timing jitter must be removed. An additional HPF function must be applied as shown in PCI Express Base Specification Revision 3.1, Figure 4-49. This parameter is measured by accumulating a record length of 10^6 UI while the DUT outputs a compliance pattern. $T_{MIN-PULSE}$ is defined to be nominally 1 UI wide and is bordered on both sides by pulses of the opposite polarity. Refer to PCI Express Base Specification Revision 3.1, Figure 4-38.
- Root Complex Tx de-emphasis is configured from Upstream controller. Downstream Tx de-emphasis is set via a command, issued at 2.5 GT/s. For detail, refer to the appropriate location in PCI Express Base Specification Revision 3.1, Section 4.2.
- Tx CM noise for 8.0 GT/s is measured at TP1 without de-embedding the breakout channel. The parameter captures device CM noise only and is not intended to capture system CM noise. For 5.0 GT/s an LPF with a -3 dB corner at 2.5 GHz is applied to the raw data. For 8.0 GT/s the filter's -3 dB corner is at 4.0 GHz.
- $I_{TX-SHORT}$ and $V_{TX-DC-CM}$ stipulate the maximum current/voltage levels that a transmitter can generate and therefore define the worst case transients that a receiver must tolerate.
- All platforms that have transmitters supporting 8.0 GT/s must implement the 176-265 nF C_{TX} value. Platforms operating at 2.5 or 5.0 GT/s only may implement over a range of 75 to 265 nF.

Table 12-7 8.0 GT/s Specific Tx Voltage and Jitter Parameters

Symbol	Parameter	Value	Units	Notes
$V_{TX-FS-NO-EQ}$	Full swing Tx voltage with no TxEq	1300 (max) 800 (min)	mVPP	See Note 1.
$V_{TX-RS-NO-EQ}$	Reduced swing Tx voltage with no TxEq	1300 (max)	mVPP	See Note 1.
$V_{TX-EIEOS-FS}$	Min swing during EIEOS for full swing	250 (min)	mVPP	See Note 2.
$V_{TX-EIEOS-RS}$	Min swing during EIEOS for reduced swing	232 (min)	mVPP	See Note 2.
T_{TX-UTJ}	Tx uncorrelated total jitter	31.25 (max)	Ps PP @ 10^{-12}	
$T_{TX-UDJDD}$	Tx uncorrelated deterministic jitter	12 (max)	Ps PP	
$T_{TX-UPW-TJ}$	Total uncorrelated PWJ	24 (max)	Ps PP @ 10^{-12}	See Notes 3 and 4.
$T_{TX-UPW-DJDD}$	Deterministic DjDD uncorrelated PWJ	10 (max)	Ps PP	See Notes 3 and 4.
T_{TX-DDJ}	Data dependent jitter	18 (max)	Ps PP	See Notes 4 and 5.
$Ps21_{TX}$	Pseudo package loss	-3.0 (min)	dB	PP ratio of 64 ones/64 zeroes pattern vs. 0101 pattern. No Tx equalization. See Note 6.
$V_{TX-BOOST-FS}$	Tx boost ratio for full swing	8.0 (min)	dB	Assumes ± 1.5 dB tolerance from diagonal elements in PCI Express Base Specification Revision 3.1, Figure 4-45.
$V_{TX-BOOST-RS}$	Tx boost ratio for reduced swing	2.5 (min)	dB	Assumes ± 1.0 dB tolerance from diagonal elements in PCI Express Base Specification Revision 3.1, Figure 4-45.
$EQ_{TX-COEFF-RES}$	Tx coefficient resolution	1/24 (max) 1/63 (min)	N/A	

Note:

- Voltage measurements for $V_{TX-FS-NO-EQ}$ and $V_{TX-RS-NO-EQ}$ are made using the 64-zeroes/64-ones pattern in the compliance pattern.
- Voltage limits comprehend both full swing and reduced swing modes. The Tx must reject any changes that would violate this specification. The maximum level is covered in the $V_{TX-FS-NO-EQ}$ measurement which represents the maximum peak voltage the Tx can drive. The $V_{TX-EIEOS-FS}$ and $V_{TX-EIEOS-RS}$ voltage limits are imposed to guarantee the EIEOS threshold of 175 mVPP at the Rx pin. This parameter is measured using the actual EIEOS pattern that is part of the compliance pattern and then removing the ISI contribution of the breakout channel. The transmitter must advertise a value for LF during TS1 at 8.0 GT/s that ensures that these parameters are met.

3. PWJ parameters shall be measured after DDJ separation.
4. Measured with optimized preset value after de-embedding to Tx pin.
5. The 18 ps number takes into account measurement error.
6. The -3.0 dB number takes into account measurement error. For some Tx package/driver combinations ps_{21TX} may be greater than 0 dB.

12.6 COMMON RECEIVER PARAMETERS

The following table defines the parameters for 2.5 GT/s, 5.0 GT/s, and 8.0 GT/s Receivers.

Table 12-8 Receiver Specifications

Symbol	Parameter	2.5 GT/s	5.0 GT/s	8.0GT/s	Units	Comments
UI	Unit Interval	399.88 (min) 400.12 (max)	199.94 (min) 200.06 (max)	124.9625 (min) 125.0375 (max)	ps	UI does not account for SSC caused variations.
$V_{RX-DIFF-PP-CC}$	Differential Rx peak-peak voltage for common Refclk Rx architecture	0.175 (min) 1.2 (max)	0.120 (min) 1.2 (max)	See	V	See PCI Express Base Specification Revision 3.1, Section 4.3.7.3.2.
$V_{RX-DIFF-PP-DC}$	Differential Rx peak-peak voltage for data clocked Rx architecture	0.175 (min) 1.2 (max)	0.100 (min) 1.2 (max)	See Table 12-11 and Table 12-12	V	See PCI Express Base Specification Revision 3.1, Section 4.3.7.3.2.
T_{RX-EYE}	Receiver eye time opening	0.40 (min)	See Table 12-9 and Table 12-10	See Table 12-11 and Table 12-12	UI	Minimum eye time at Rx pins to yield a 10^{-12} BER. See Note 1.
$T_{RX-TJ-CC}$	Max Rx inherent timing error	N/A	0.40 (max)	See Table 12-11 and Table 12-12	UI	Max Rx inherent total timing error for common Refclk Rx architecture. See Note 2.
$T_{RX-TJ-DC}$	Max Rx inherent timing error	N/A	0.34 (max)	See Table 12-11 and Table 12-12	UI	Max Rx inherent total timing error for data clocked Rx architecture. See Note 2.
$T_{RX-DJ-DD-CC}$	Max Rx inherent deterministic timing error	N/A	0.30 (max)	See Table 12-11 and Table 12-12	UI	Max Rx inherent deterministic timing error for common Refclk Rx architecture. See Note 2.
$T_{RX-DJ-DD-DC}$	Max Rx inherent deterministic timing error	N/A	0.24 (max)	See Table 12-11 and Table 12-12	UI	Max Rx inherent deterministic timing error for data clocked Rx architecture. See Note 2.
$T_{RX-EYE-MEDIAN-10-MAX-JITTER}$	Max time delta between median and deviation from median	0.3 (max)	Not specified	Not specified	UI	Only specified for 2.5 GT/s.
$T_{RX-MIN-PULSE}$	Minimum width pulse at Rx	Not specified	0.6 (min)	Not specified	UI	Measured to account for worst Tj at 10^{-12} BER. See PCI Express Base Specification Revision 3.1, Figure 4-38.
$V_{RX-MAX-MIN-RATIO}$	Min/max pulse voltage on consecutive UI	Not specified	5 (max)	Not specified	-	Rx eye must simultaneously meet V_{RX-EYE} limits.
BW_{RX-PLL}	Rx PLL BW for 2.5 GT/s	22 (max) 1.5 (min)	Not specified	Not specified	MHz	See Note 3.
$BW_{RX-PKG-PLL1}$	Rx PLL bandwidth corresponding to $PKG_{RX-PLL1}$	Not specified	16 (max) 8 (min)	4 (max) 2 (min)	MHz	Second order PLL jitter transfer bounding function. See Note 3.
$BW_{RX-PKG-PLL2}$	Rx PLL bandwidth corresponding to $PKG_{RX-PLL2}$	Not specified	16 (max) 5 (min)	5 (max) 2 (min)	MHz	Second order PLL jitter transfer bounding function. See Note 3.
$PKG_{RX-PLL1}$	Rx PLL peaking limit #1	Not specified	3.0 (max)	2.0 (max)	dB	PLL BW = 8 MHz (min) @ 5.0 GT/s or BW = 4 MHz (max) @ 8.0 GT/s. See Note 3.
$PKG_{RX-PLL2}$	Rx PLL peaking limit #2	Not specified	1.0 (max)	1.0 (max)	dB	PLL BW = 5 MHz (min) @ 5.0 GT/s or BW = 5 MHz (max) @ 8.0 GT/s. See Note 3.
$RL_{RX-DIFF}$	Rx package plus	10 (min)	10 (min) for	10 (min) for	dB	See PCI Express Base

Symbol	Parameter	2.5 GT/s	5.0 GT/s	8.0GT/s	Units	Comments
	Si differential return loss		0.05 - 1.25 GHz 8 (min) for > 1.25 - 2.5 GHz	0.05 - 1.25 GHz 8 (min) for > 1.25 - 2.5 GHz 5 (min) for > 2.5 - 4 GHz		Specification Revision 3.1, Figure 4-60 and Note 4.
RL _{RX-CM}	Common mode Rx return loss	6 (min)	6 (min)	6 (min) for 0.05 - 2.5 GHz 5 (min) for > 2.5 - 4.0 GHz	dB	See PCI Express Base Specification Revision 3.1, Figure 4-60 and Note 4.
Z _{RX-DC}	Receiver DC single ended impedance	40 (min) 60 (max)	40 (min) 60 (max)	Not specified	Ω	DC impedance limits are needed to guarantee Receiver detect. For 8.0 GT/s is bounded by RL _{RX-CM} . See Note 5.
T _{RX-GND-FLOAT}	Rx termination ground float time	Not specified	Not specified	500	μs	Time allowed to float Rx internal ground in 2.5 GT/s/ 5.0 GT/s to 8.0 GT/s configuration change. See Note 8.
Z _{RX-DIFF-DC}	DC differential impedance	80 (min) 120 (max)	Not specified	Not specified	Ω	For 5.0 GT/s and 8.0 GT/s covered under the RL _{RX-DIFF} parameter. See Note 5.
V _{RX-CM-AC-P}	Rx AC common mode voltage	150 (max)	150 (max)	75 mV (max) (EH < 100 mVPP) 125 mV (max) (EH < 100 mVPP). See Table 12-11	mVP	Measured at Rx pins into a pair of 50 Ω terminations into ground. See Note 6.
Z _{RX-HIGH-IMP-DC-POS}	DC input CM Input Impedance for V > 0 during Reset or power down	≥10 k or ≥20 k	≥10 k or ≥20 k	≥10 k or ≥20 k	Ω	Rx DC CM impedance with the RX terminations not powered. ≥10 kΩ over 0-200 mV range wrt. Ground and ≥20 kΩ for voltages ≥200 mV wrt ground. See Note 9.
Z _{RX-HIGH-IMP-DC-NEG}	DC input CM input Impedance for V < 0 during Reset or power down	1.0 k (min)	1.0 k (min)	1.0 k (min)	Ω	Rx DC CM impedance with the Rx terminations not powered, measured over the range -150 to 0 mV with respect to ground. See Note 7.
V _{RX-IDLE-DET-DIFF-P}	Electrical Idle Detect Threshold	65 (min) 175 (max)	65 (min) 175 (max)	65 (min) 175 (max)	mV	$V_{RX-IDLE-DET-DIFF-P} = 2 * V_{RX-D+} - V_{RX-D-} $. Measured at the package pins of the Receiver. See PCI Express Base Specification Revision 3.1, Section 4.2.4.3.
T _{RX-IDLE-DET-DIFF-ENTERTIME}	Unexpected Electrical Idle Enter Detect Threshold Integration Time	10 (max)	10 (max)	10 (max)	ms	An unexpected Electrical Idle ($V_{RX-DIFF-PP} < V_{RX-IDLE-DET-DIFF-P}$) must be recognized on longer than T _{RX-IDLE-DET-DIFF-ENTERTIME} to signal an unexpected idle condition.
L _{RX-SKEW}	Lane to Lane skew	20 (max)	8 (max)	6 (max)	ns	Across all Lanes on a Ports. L _{RX-SKEW} comprehends Lane-Lane variations due to channel and repeater delay differences.

Note:

- Receiver eye margins are defined into a 2x 50 Ω reference load.
- The four inherent timing error parameters are defined for the convenience of Rx designers, and they are measured during Receiver tolerancing.
- Two combinations of PLL BW and peaking are specified at ≥5.0 GT/s to permit designers to make tradeoffs between the two parameters. If the PLL's min BW is ≥8 MHz, then up to 3.0 dB of peaking is permitted. If the PLL's min BW is relaxed to ≥5.0MHz, then a tighter peaking value of 1.0 dB must be met. Note: a PLL BW extends from zero up to value(s) defined as the min or max in the above table. For 2.5 GT/s a single PLL bandwidth and peaking value of 1.5-22 Mhz and 3.0 dB are defined.
- Measurements must be made for both common mode and differential return loss. In both cases the DUT must be powered up and DC isolated, and its D+/D- inputs must be in the low-Z state.
- The Rx DC single ended impedance must be present when the Receiver terminations are first enabled to ensure that the Receiver Detect occurs properly. Compensation of this impedance can start immediately and the Rx Common Mode Impedance (Constrained by RL_{RX-CM} to 50 Ω ±20%) must be within the specified range by the time Detect is entered.
- Common mode peak voltage is defined by the expression: $\max\{|(V_{D+}-V_{D-}) - V_{CMDC}|\}$.

- $Z_{RX-HIGH-IMP-DC-NEG}$ and $Z_{RX-HIGH-IMP-DC-POS}$ are defined respectively for negative and positive voltages at the input of the Receiver. Transmitter designers need to comprehend the large difference between >0 and <0 Rx impedances when designing Receiver detect circuits.
- Defines the time for the receiver's input pads to settle to new common-mode on 2.5 GT/s/5.0 GT/s transition to 8.0 GT/s.
- For voltage >500 mV the effects of Rx ESD structures may limit $Z_{RX-HIGH-IMP-DC-POS}$ to values less than 20 K Ω .

Table 12-9 5.0 GT/s Tolerancing Limits for Common Refclk Rx Architecture

Parameter	Description	Min	Max	Units	Notes
UI	Unit interval without including of SSC	199.94	200.06	ps	Over 10^6 UI
$T_{RX-HF-RMS}$	1.5 – 100 MHz RMS jitter		3.4	ps RMS	Spectrally flat, see Note 3
$T_{RX-HF-DJ-DD}$	Max Dj impinging on Rx under test		88	ps	See Notes 2 and 4
$T_{RX-SSC-RES}$	33 kHz Refclk residual	--	75	ps	
$T_{RX-LF-RMS}$	< 1.5 MHz RMS jitter	--	4.2	ps RMS	Spectrally flat
$T_{RX-MIN-PULSE}$	Minimum single pulse applied at Rx	120		ps	See Note 2
$V_{RX-MIN-MAX-RATIO}$	Min/max pulse voltage ratio seen over an time interval of 2 UI	--	5		See Note 2
V_{RX-EYE}	Receive eye voltage opening	120		mVPP diff	See Notes 1 and 3
$V_{RX-CM-CH-SRC}$	Common mode noise from Rx	--	300	mVPP	See Note 2

Note:

- Refer to PCI Express Base Specification Revision 3.1, Figure 4-63 for a description of how the Rx eye voltage is defined.
- Accumulated over 10^6 UI.
- Minimum eye is obtained by first injecting maximum Dj and then adjusting Rj until a minimum eye (defined by T_{RX-EYE} as show in PCI Express Base Specification Revision 3.1, Figure 4-63) is reached. Rj is spectrally flat before being filtered with a BPF having 3 dB cut-offs f_{C-LOW} and f_{C-HIGH} of 1.5 MHz and 100 MHz, respectively with step rolloff at 1.5 MHz and a 20 dB/decade rolloff on the high side. Minimum eye width is defined for a sample size equivalent to a BER of 10^{-12} .
- Different combinations of $T_{RX-HF-DJ-DD}$ and $T_{RX-HF-RMS}$ are needed to measure $T_{RX-TJ-CC}$ and $T_{RX-DJ-DD-CC}$.

Table 12-10 5.0 GT/s Tolerancing Limits for Data Clocked Rx Architecture

Parameter	Description	Min	Max	Units	Notes
UI	Unit interval without including of SSC	199.94	200.06	ps	Over 10^6 UI
$T_{RX-HF-RMS}$	1.5 – 100 MHz RMS jitter		4.2	ps RMS	Spectrally flat, see Note 3
$T_{RX-HF-DJ-DD}$	Max Dj impinging on Rx under test		88	ps	See Notes 2 and 4
$T_{RX-SSC-RES}$	33 kHz Refclk residual	--	20	ps	
$T_{RX-LF-RMS}$	< 1.5 MHz RMS jitter	--	8.0	ps RMS	Spectrally flat
$T_{RX-MIN-PULSE}$	Minimum single pulse applied at Rx	120		ps	See Note 2
$V_{RX-MIN-MAX-RATIO}$	Min/max pulse voltage ratio seen over an time interval of 2 UI	--	5		See Note 2
V_{RX-EYE}	Receive eye voltage opening	120		mVPP diff	See Notes 1 and 3
$V_{RX-CM-CH-SRC}$	Common mode noise from Rx	--	300	mVPP	See Note 2

Note:

- Refer to PCI Express Base Specification Revision 3.1, Figure 4-63 for a description of how the Rx eye voltage is defined.
- Accumulated over 10^6 UI.
- Minimum eye is obtained by first injecting maximum Dj and then adjusting Rj until a minimum eye (defined by T_{RX-EYE} as show in PCI Express Base Specification Revision 3.1, Figure 4-63) is reached. Rj is spectrally flat before being filtered with a BPF having 3 dB cut-offs f_{C-LOW} and f_{C-HIGH} of 1.5 MHz and 100 MHz, respectively with step rolloff at 1.5 MHz and a 20 dB/decade rolloff on the high side. Minimum eye width is defined for a sample size equivalent to a BER of 10^{-12} .
- Different combinations of $T_{RX-HF-DJ-DD}$ and $T_{RX-HF-RMS}$ are needed to measure $T_{RX-TJ-CC}$ and $T_{RX-DJ-DD-CC}$.

Table 12-11 Stressed Voltage Eye Parameters

Symbol	Parameter	Limits at 8.0GT/s	Units	Comments
$V_{RX-LAUNCH-8G}$	Generator launch voltage	800	mVPP	Measured at TP1. Please refer to PCI Express Base Specification Revision 3.1, Figures 4-65. $V_{RX-LAUNCH-8G}$ may be adjusted if necessary to yield the proper EH as long as the outside eye voltage at TP2 does not exceed 1300 mVPP.
$T_{RX-UI-8G}$	Unit Interval	125.00	ps	Nominal value is sufficient for Rx tolerancing. Value does not account for SSC.
$V_{RX-SV-8G}$	Eye height at TP2P	25 (-20 dB channel) 50 (-12 dB channel) 200 (-3 dB channel)	mVPP	Eye height @ BER = 10^{-12} . See Notes 1 and 2.

Symbol	Parameter	Limits at 8.0GT/s	Units	Comments
T _{RX-SV-8G}	Eye width at TP2P	0.3 to 0.35	UI	Eye width at BER = 10 ⁻¹² . See Note 2.
V _{RX-SV-DIFF-8G}	Differential mode interference	14 or greater	mVPP	Adjusted to set EH/ Frequency = 2.10 GHz. See Note 3.
V _{RX-SV-CM-8G}	Rx AC Common mode voltage at TP2P	150 (EH < 100 mVPP) 250 (EH ≥ 100 mVPP)	mVPP	Defined for a single tone at 120 MHz. See Note 3.
T _{RX-SV-SJ-8G}	Sinusoidal Jitter at 100 MHz	0.1	UI PP	Fixed at 100 MHz. See Note 4.
T _{RX-SV-RJ-8G}	Random Jitter	2.0	Ps RMS	Rj spectrally flat before filtering. See Notes 4 and 5.
V _{RX-MAX-SE-SW}	Max single-ended swing	±300	mVP	See Note 6.

Note:

- V_{RX-SV-8G} is tested at three different voltages to ensure the Rx DUT is capable of equalizing over range of channel loss profiles. The test also guarantees the Rx is capable of operating over a sufficient dynamic range of eye heights. This “SV” in the parameter names refers to stressed voltage.
- V_{RX-ST-8G} and T_{RX-ST-8G} are referenced to TP2P and are obtained after post processing data captured at TP2. V_{RX-ST-8G} and T_{RX-ST-8G} include the effects of applying the behavioral Rx model and Rx behavioral equalization.
- V_{RX-SV-DIFF-8G} measurement is made at TP2 without post processing. V_{RX-SV-CM-8G} may be made at either TP1 or TP2. V_{RX-SV-DIFF-8G} voltage may need to be adjusted over a wide range for the different loss calibration channels.
- T_{RX-SV-SJ-8G} and T_{RX-SV-RJ-8G} measurements are made at TP1 without post processing.
- Rj is applied over the following range. The low frequency limit may be between 1.5 and 10 MHz, and the upper limit is 1.0GHz. See PCI Express Base Specification Revision 3.1, Figure 4-47 for details.
- V_{RX-MAX-SE-SW} sets the maximum outer, single-ended eye voltage limit in the presence of differential and CM noise applied to the Rx, as observed at TP2 relative to ground with no behavioral RxEq post processing.

Table 12-12 Stressed Jitter Eye Parameters

Symbol	Parameter	Limits at 8.0GT/s	Units	Comments
V _{RX-LAUNCH-8G}	Generator launch voltage	800 (nominal)	mVPP	Measured at TP1, See PCI Express Base Specification Revision 3.1, Figure 4-65 and Note 1.
T _{RX-UI-8G}	Unit Interval	125.00	ps	Nominal value is sufficient for Rx tolerancing. Value does not account for SSC.
V _{RX-ST-8G}	Eye height at TP2P	25 (min) 35 (max)	mVPP	At BER = 10 ⁻¹² . See Note 2.
T _{RX-ST-8G}	Eye width at TP2P	0.30	UI	At BER = 10 ⁻¹² . See Note 2.
T _{RX-ST-SJ-8G}	Sinusoidal Jitter	0.1 - 1.0	UI PP	See PCI Express Base Specification Revision 3.1, Figure 4-74 Measured at TP1. See Note 3.
T _{RX-ST-RJ-8G}	Random Jitter	3.0	ps RMS	Rj spectrally flat before filtering. Measured at TP1, See Note 4.

Note:

- V_{RX-SV-8G} may be adjusted to meet V_{RX-ST-8G} as long as the outside eye voltage at TP2 does not exceed 1300 mVPP.
- V_{RX-ST-8G} and T_{RX-ST-8G} are referenced to TP2P and are obtained after post processing data captured at TP2. V_{RX-ST-8G} and T_{RX-ST-8G} include the effects of applying the behavioral Rx model and Rx behavioral equalization.
- T_{RX-ST-SJ-8G} may be measured at either TP1 or TP2.
- While the nominal value is specified at 3.0 ps RMS, it may be adjusted to meet the 0.3 UI value for T_{RX-ST-8G}. Rj is measured at TP1 to prevent data-channel interaction from adversely affecting the accuracy of the Rj calibration. Rj is applied over the following range. The low frequency limit may be between 1.5 and 10 MHz, and the upper limit is 1.0 GHz.

12.7 POWER CONSUMPTION

Table 12-13 Power Consumption

Active Lane#	Link Speed (GT/s)	Tj (°C)	0.95VDDC		0.95VP		0.95CVDDC		1.8VDDR		1.8CVDDR		1.8VPH		Total (W)
			Current (A)	Power (W)	Current (A)	Power (W)	Current (A)	Power (W)	Current (A)	Power (W)	Current (A)	Power (W)	Current (A)	Power (W)	
16	8.0	25	1.91	1.81	1.01	0.96	0.01	0.01	0.01	0.02	0.06	0.11	0.27	0.49	3.40
16	8.0	80	2.58	2.45	1.05	1.00	0.01	0.01	0.01	0.02	0.06	0.11	0.29	0.52	4.11
16	8.0	125	4.10	3.90	1.13	1.07	0.01	0.01	0.01	0.02	0.06	0.11	0.30	0.54	5.65

Note:

1. Power consumption measurement conditions:

- Port Configuration: 816
- Down Ports: Full-loading, 7 SSD cards plugged

2. Power consumption in the table is a reference, be affected by various environments, bus traffic and power supply etc.

13 THERMAL DATA

Table 13-1 lists sample simulation thermal data for PI7C9X3G816GP at Industrial Temperature.

Table 13-1 Sample Simulation Thermal Data

PCB Structure	Airflow Velocity	Θ_{JA} (°C/W)	Ψ_{JB} (°C/W)	Ψ_{JT} (°C/W)	Θ_{JC} (°C/W)	Heat Sink
Customized 10L PCB	Still air	6.54	3.64	1.93	1.89	Alpha LPD40-25B
	Still air	10.98	5.84	1.69		No
	1 m/s	9.90	5.69	1.72		
	2 m/s	9.39	5.57	1.73		

Note:

1. Θ_{JA} : Thermal Resistance, Junction-to-Ambient
2. Θ_{JC} : Thermal Resistance, Junction-to-Case
3. Ψ_{JT} : Junction to top center thermal characterization
4. Ψ_{JB} : Junction to board thermal characterization
5. Thermal data is based upon simulation
6. Simulation conditions
 - PCB Condition: Customized 10L PCB
 - Substrate: 0.76 mm 8L
 - Thermal power dissipation: maximum power is assumed to be at 8.0 GT/s, as listed in Table 12-13.
 - Ambient temperature: 85°C
 - Thermal criteria: junction temperature < 125°C

14 PACKAGE INFORMATION

The package of PI7C9X3G816GP is a 19mm x 19mm HFCBGA (324 Pin) package with ball pitch 1.0mm. The detailed package information, mechanical dimension and package of drawing are shown below.

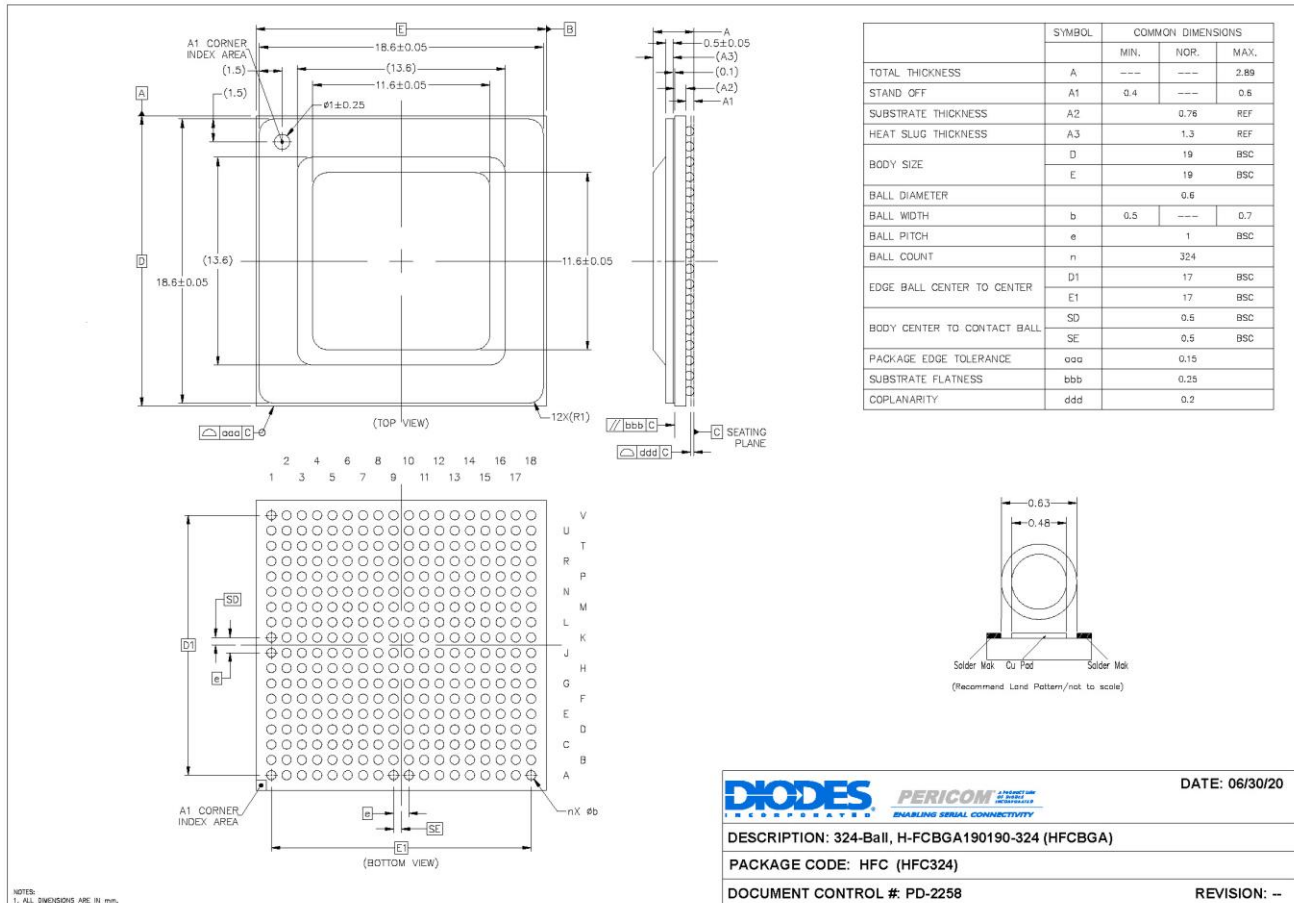

Figure 14-1 Package of Drawing



YY: Year
 WW: Workweek
 1st X: Assembly Code
 2nd X: Fab Code
 XXXXXXXX.** = Assy Lot#

Figure 14-2 Part Marking

15 ORDERING INFORMATION

Part Number	Package Code	Package Description	Pb-Free & Green
PI7C9X3G816GPBHFCE	HFC	324-pin HFCBGA 19mm x 19mm	Yes

Notes:

1. No purposely added lead. Fully EU Directive 2002/95/EC (RoHS), 2011/65/EU (RoHS 2) & 2015/863/EU (RoHS 3) compliant.
2. See <https://www.diodes.com/quality/lead-free/> for more information about Diodes Incorporated's definitions of Halogen- and Antimony-free, "Green" and Lead-free.
3. Halogen- and Antimony-free "Green" products are defined as those which contain <900ppm bromine, <900ppm chlorine (<1500ppm total Br + Cl) and <1000ppm antimony compounds.

