

THIS DRAWING IS UNPUBLISHED. RELEASED FOR PUBLICATION 20
 © COPYRIGHT 20 BY - ALL RIGHTS RESERVED.

REVISIONS					
P	LTR	DESCRIPTION	DATE	DWN	APVD
D1		REVISED PER ECR-19-012620	20AUG2019	PC	SW
E		REVISED PER ECR-23-169188	16MAR2023	MV	JP
E1		REVISED PER ECR-23-175978	26MAY2023	MV	JP

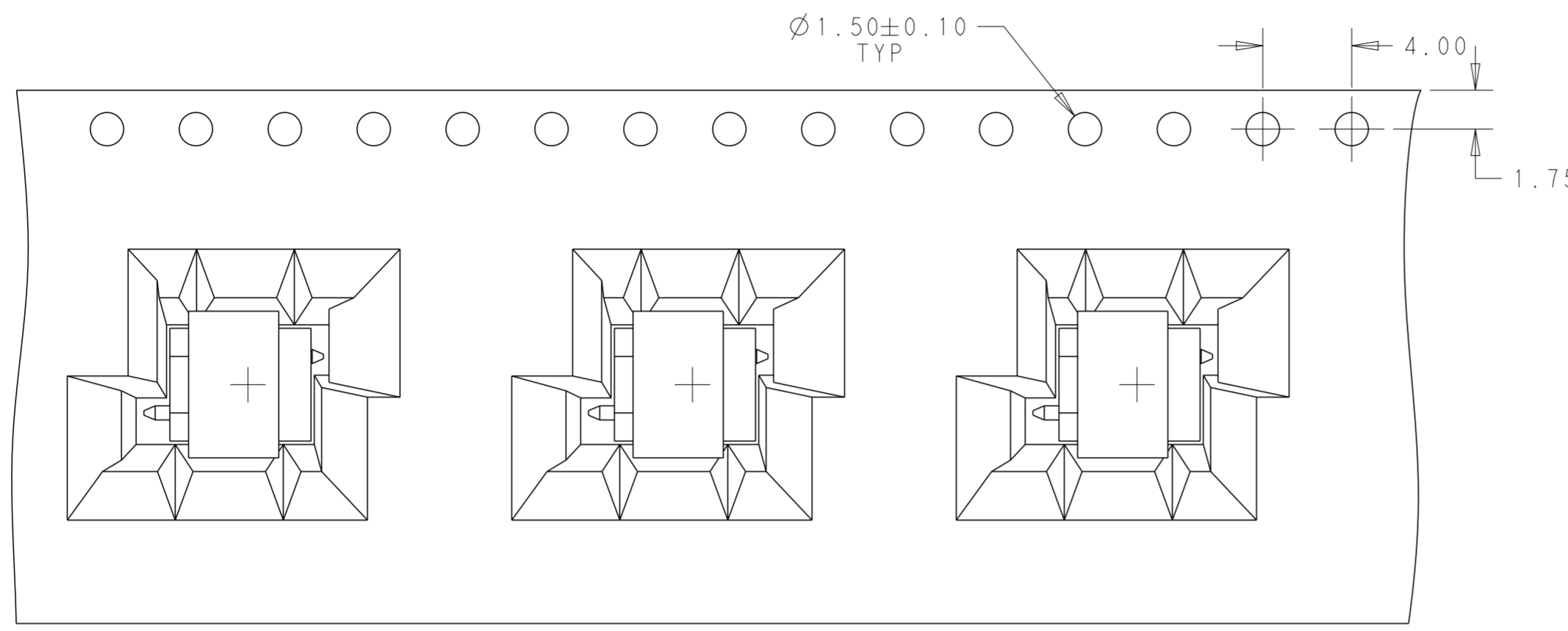

- 1 MATERIAL:
HOUSING- THERMOPLASTIC, UL94V-0, BLACK
CONTACT- COPPER ALLOY
CAVITY CARRIER TAPE- BLACK CONDUCTIVE PLOYCARBONATE
- 2 FINISH:
CONTACT - TIN PLATE FOR -3, GOLD PLATE FOR 1--2,1--3.
- 3 POSTS SOLDERTAILS MUST COMPLY WITH TE SOLDERABILITY SPEC 109-11-12.
- 4 HEADER ARE SUPPLIED ON A 330.2mm DIAMETER REEL WITH 225 PARTS PER REEL. THE CAVITY CARRIER TAPE HOLDS 1 PART PER POKCKET, ORIENTED AS SHOW.
- 5 PRIMARY REELING DIRECTION
- 6 REVERSE-REELING DIRECTION

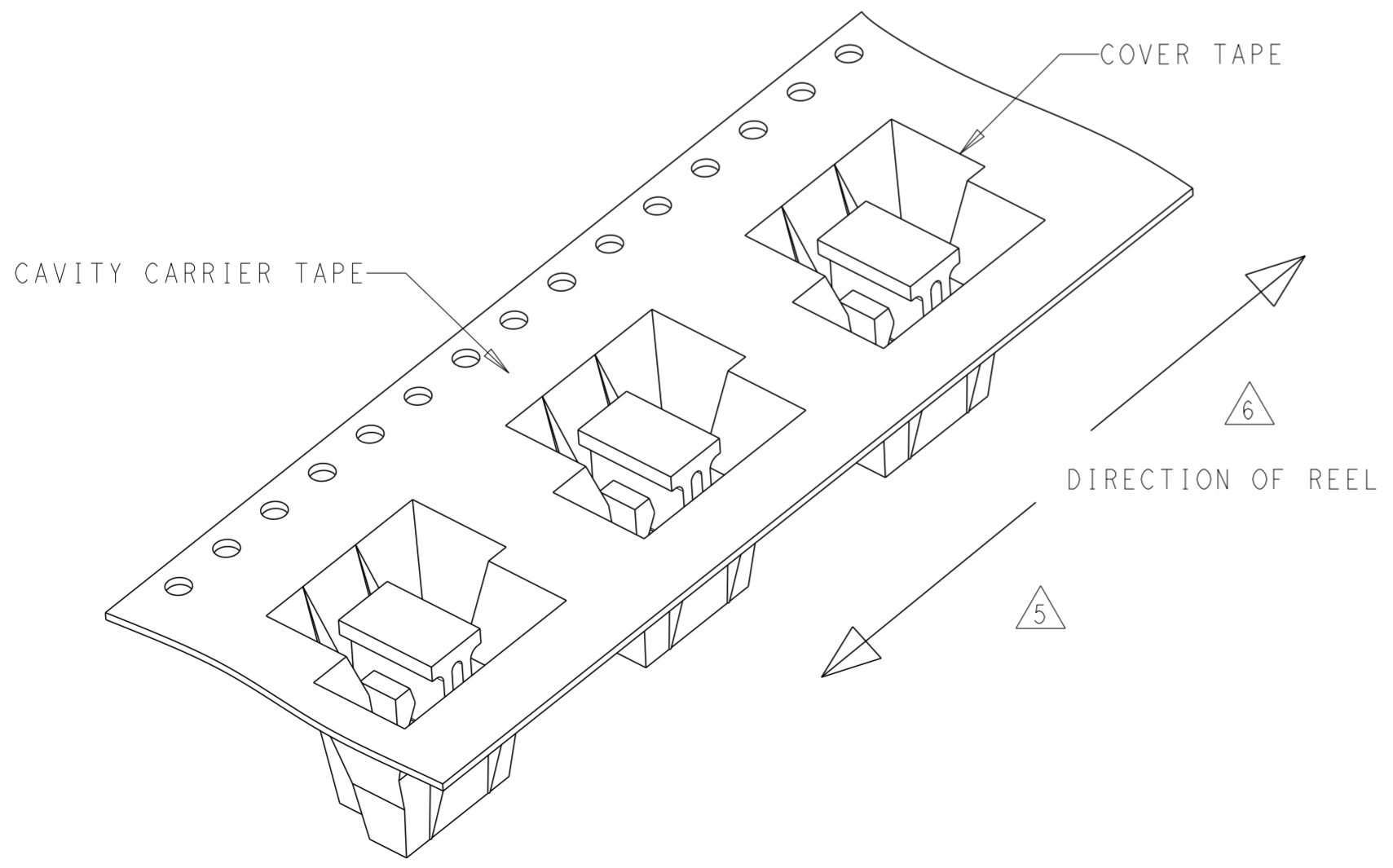
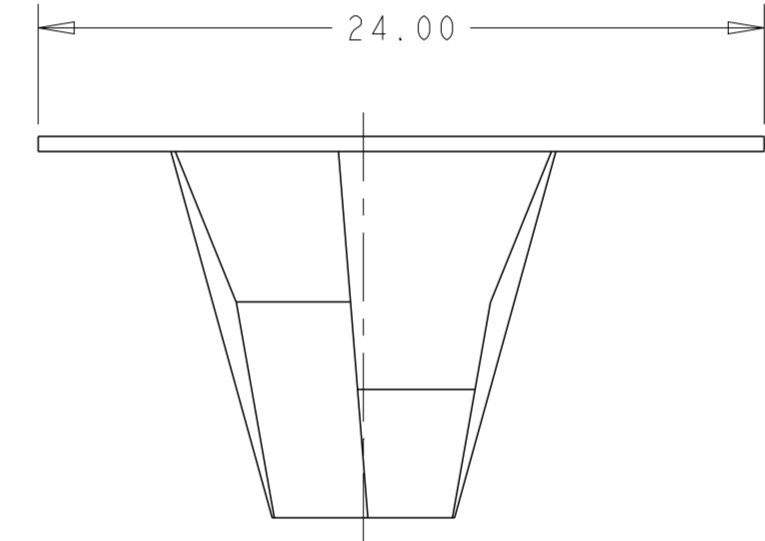
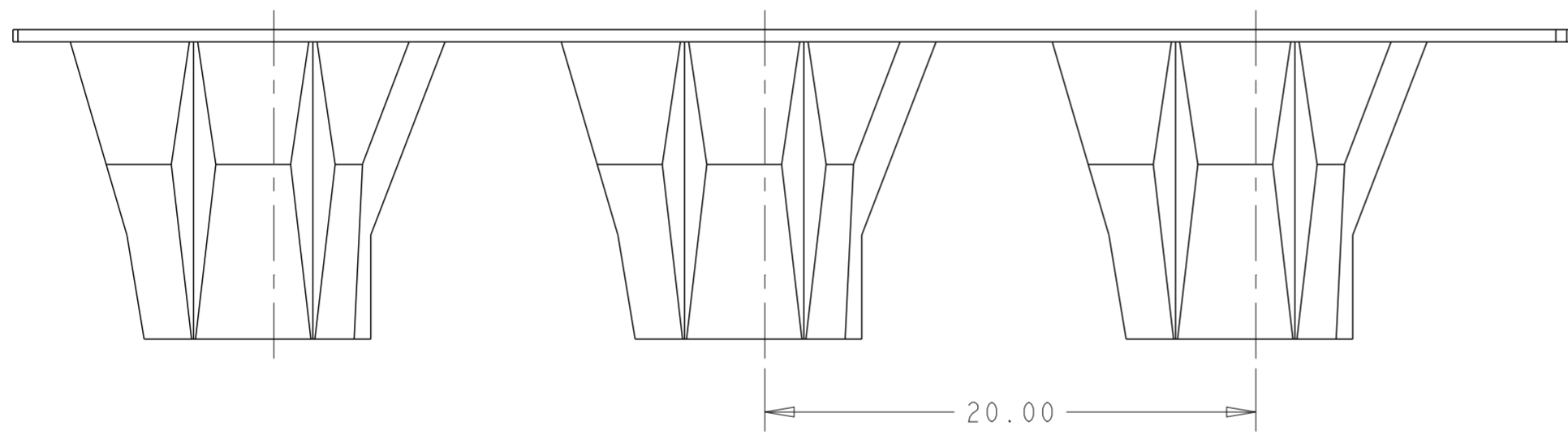

6	972366-3	1706504-2	147117-1	2	3-647166-2	2-2232980-2
6	972366-4	1706504-4	147117-1	4	3-647167-4	1-2232980-4
6	972366-3	1706504-3	147117-1	3	3-647166-3	2-2232980-3
5	972366-3	1706504-3	147117-1	3	3-647167-3	1-2232980-3
5	972366-3	1706504-2	147117-1	2	3-647167-2	1-2232980-2
5	972366-3	1706504-3	147117-1	3	3-647166-3	2232980-3
5	972366-3	1706504-2	147117-1	2	3-647166-2	2232980-2
DIRECTION OF REELING	COVER TAPE	CAVITY CARRIER COVER	PICK AND PLACE COVER	POSITION	HEADER ASSEMBLY	PART NUMBER

THIS DRAWING IS A CONTROLLED DOCUMENT.

DWN P.Q	30 JUN 2015	 TE Connectivity
CHK D.7	30 JUN 2015	
APVD D.7	30 JUN 2015	

DIMENSIONS: MM
 TOLERANCES UNLESS OTHERWISE SPECIFIED:
 0 PLC ±
 1 PLC ±
 2 PLC ±0.20
 3 PLC ±
 4 PLC ±
 ANGLES ±1°
 FINISH

MATERIAL 1
 FINISH 2

PRODUCT SPEC	108-1050	NAME	MTA100 HDR ASSY SURFACE MOUNT, FRICTION LOCK, .025 SQUARE STRAIGHT POST
APPLICATION SPEC	114-1019	SIZE	
WEIGHT	-	CAGE CODE	A200779
CUSTOMER DRAWING	SCALE 4:1	DRAWING NO	C-2232980
	SHEET 1 OF 2	RESTRICTED TO	-
	REV E1		

THIS DRAWING IS UNPUBLISHED. RELEASED FOR PUBLICATION 20
 © COPYRIGHT 20 BY - ALL RIGHTS RESERVED.

REVISIONS				
P	LTR	DESCRIPTION	DATE	APVD
-	-	SEE SHEET 1	-	-

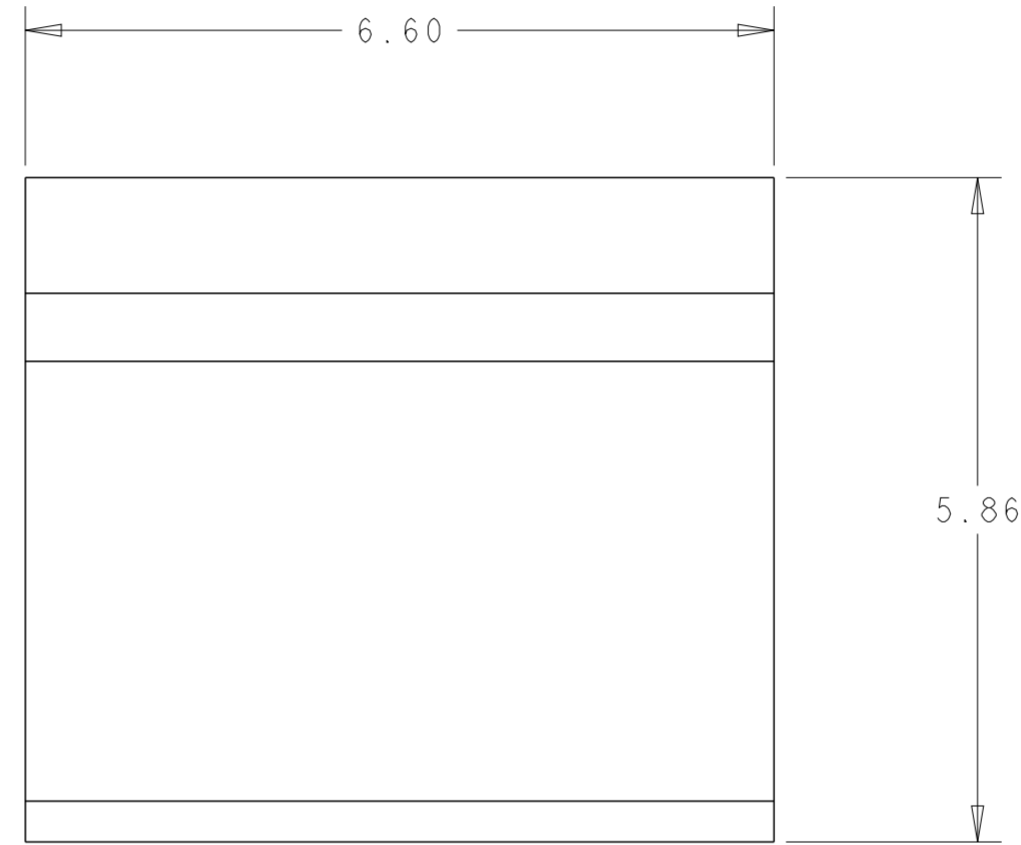
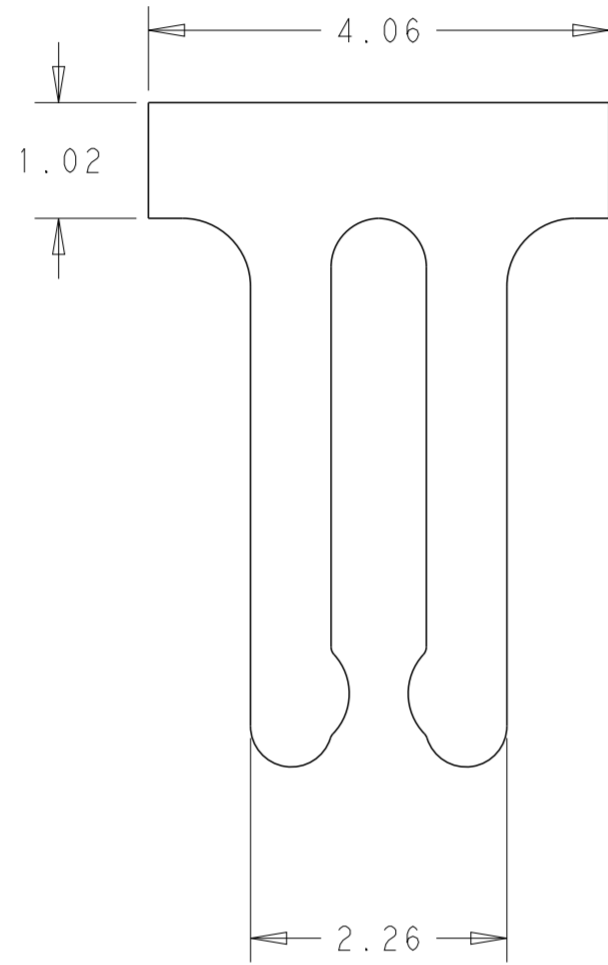

CAP FOR HEADER

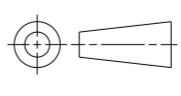
THIS DRAWING IS A CONTROLLED DOCUMENT.		DWN P. Q	30 JUN 2015	 TE Connectivity	
DIMENSIONS: MM		CHK D. 7	30 JUN 2015		
		APVD D. 7	30 JUN 2015		
TOLERANCES UNLESS OTHERWISE SPECIFIED:		PRODUCT SPEC		NAME	
0 PLC ±	1 PLC ±	108-1050		MTA-100 HDR ASSEMBLY, SURFACE MOUNT, FRICTION LOCK, .025 SQUARE STRAIGHT POST	
2 PLC ±0.20	3 PLC ±	APPLICATION SPEC		SIZE	CAGE CODE
4 PLC ±	ANGLES ±1°	114-1019		A2	00779
MATERIAL	FINISH	WEIGHT		DRAWING NO	RESTRICTED TO
1	2	-		C-2232980	-
CUSTOMER DRAWING				SCALE	SHEET
				4:1	2 OF 2
				REV	E1