

MATERIALS AND FINISHES:

BODY: BRASS
PLATED GOLD

CENTER CONTACT: BRASS
PLATED GOLD

INSULATOR: TEFLON

ELECTRICAL CHARACTERISTICS:

FREQUENCY RATING: 0 TO 40 GHz
VSWR: 1.50 MAX
INSERTION LOSS: 0.12 √F (GHz) dB MAX

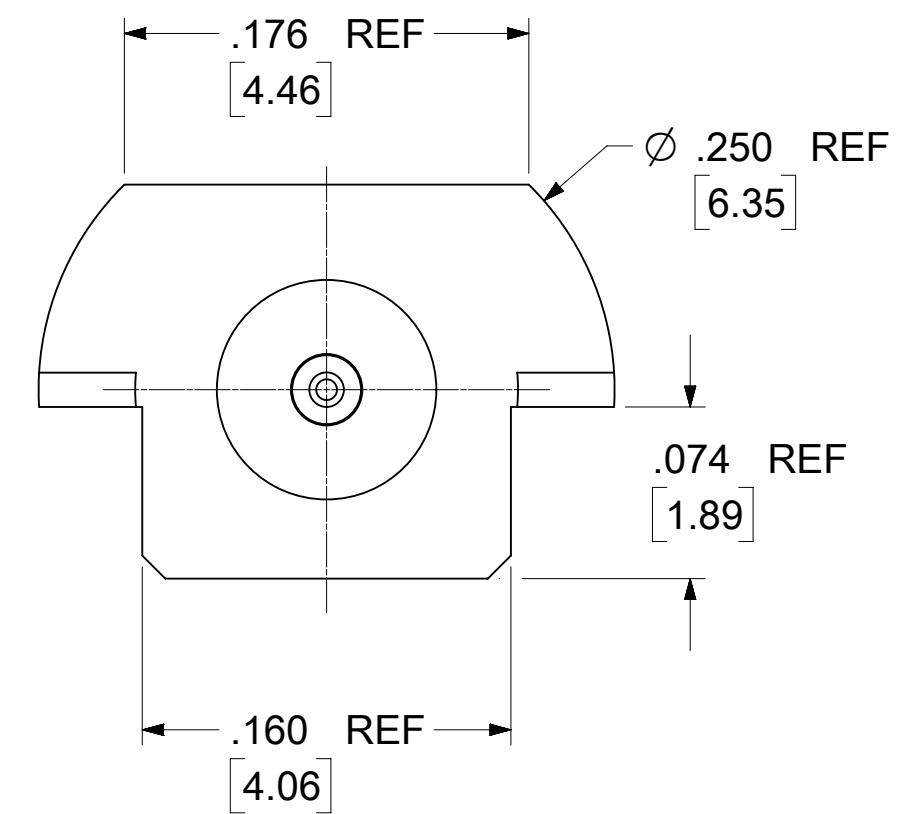
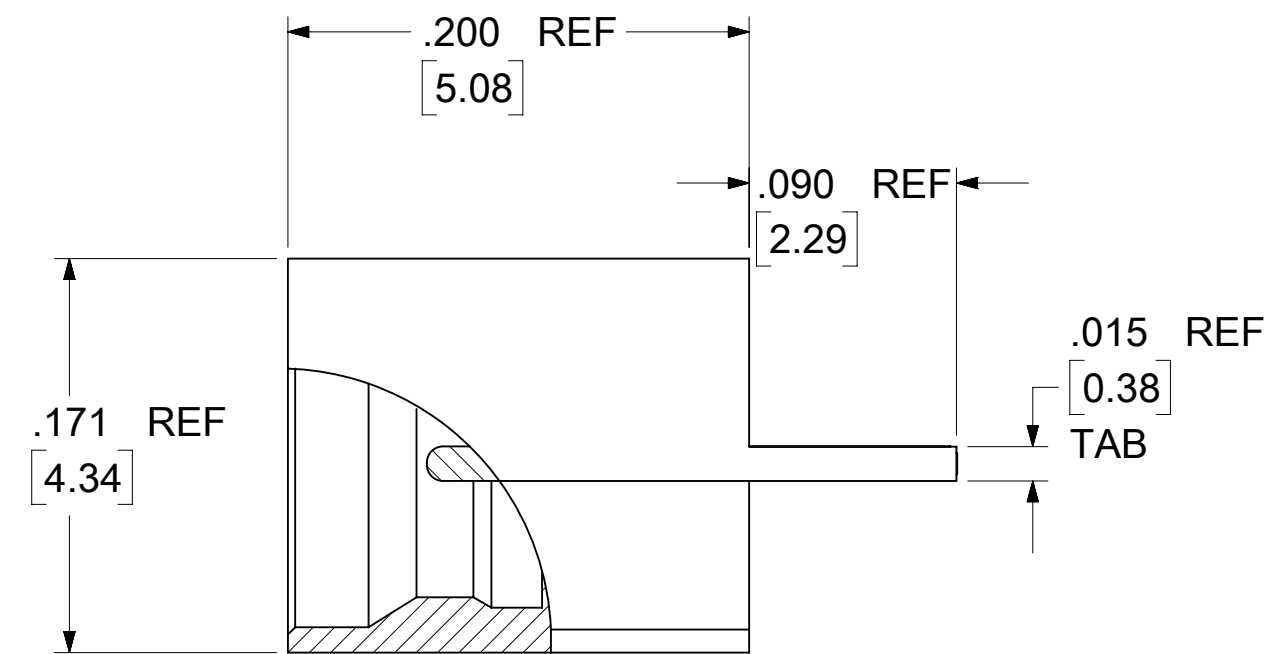
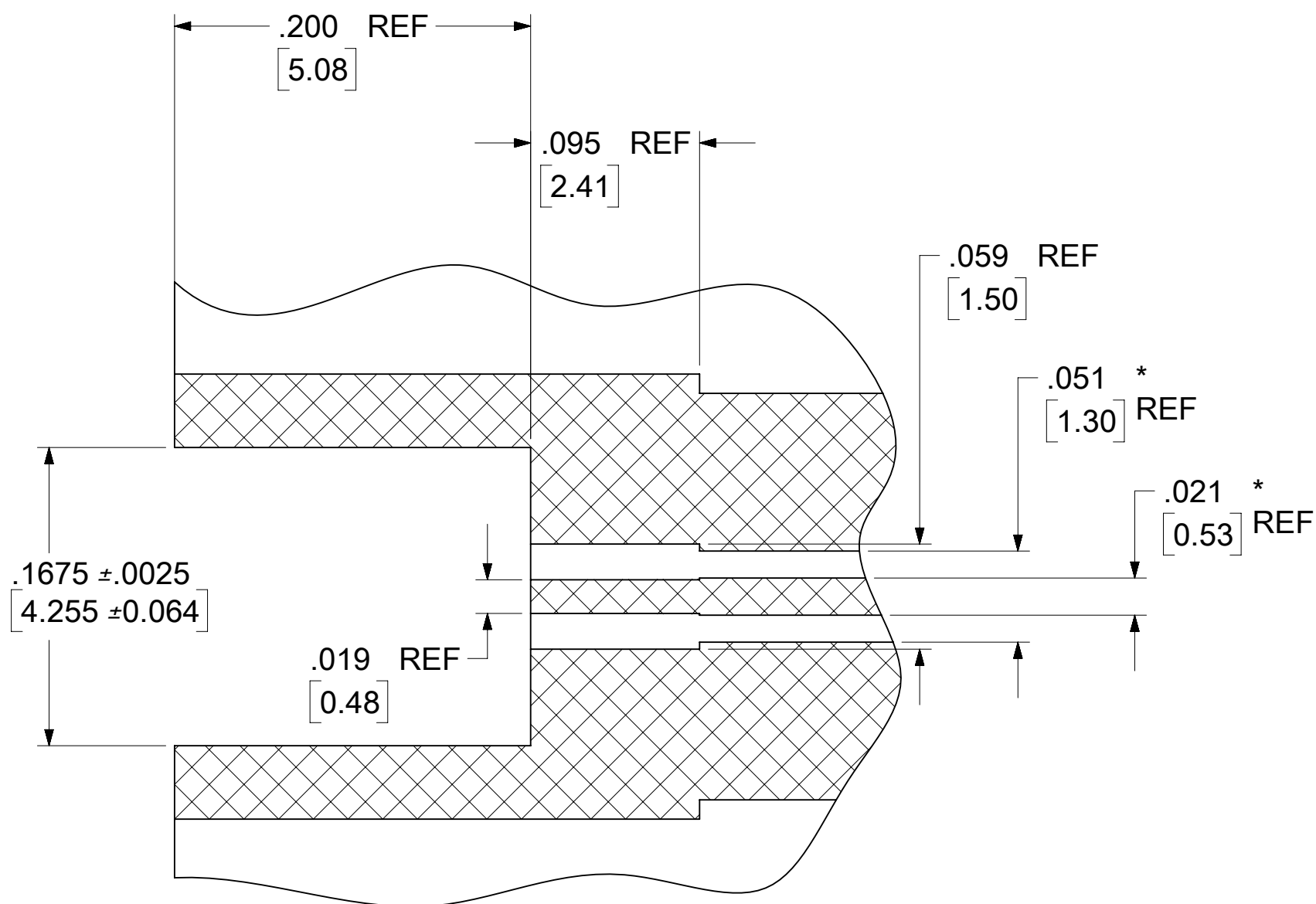
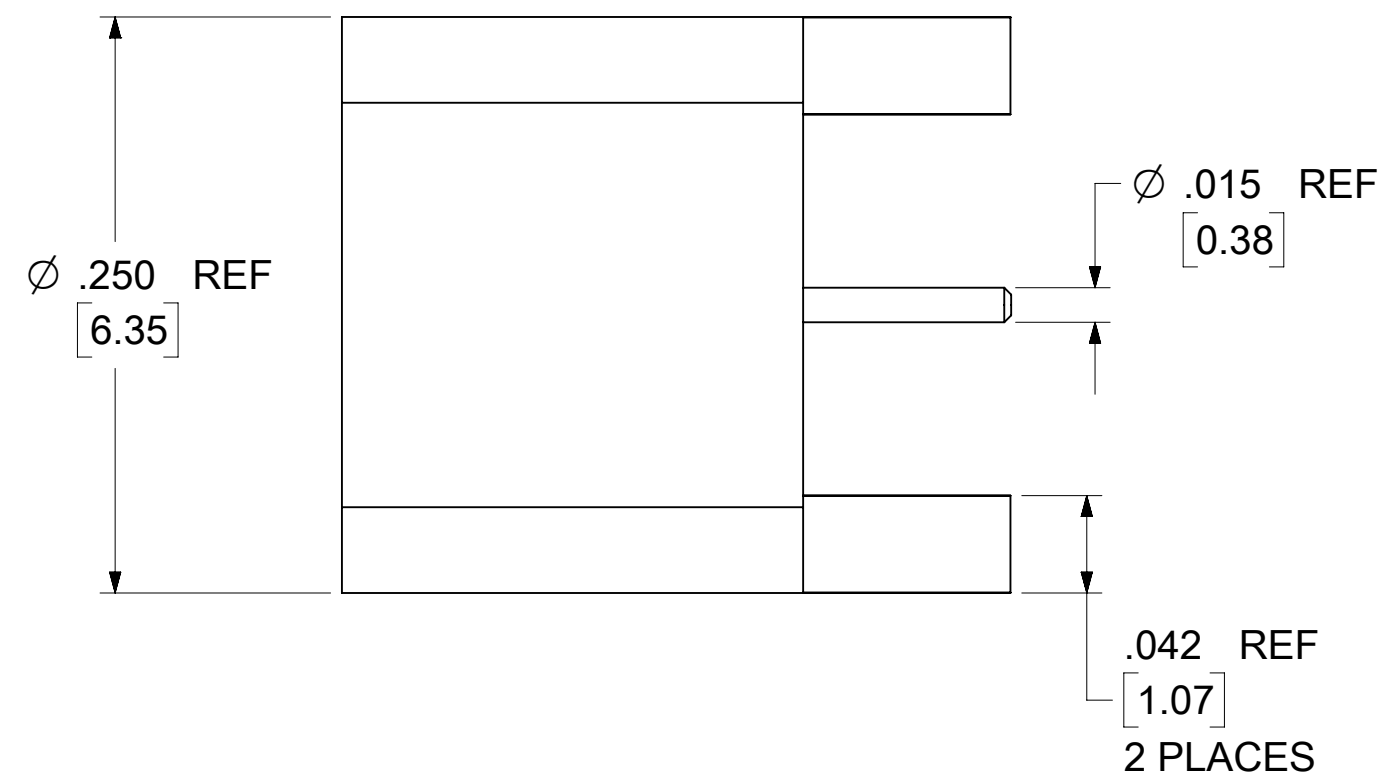
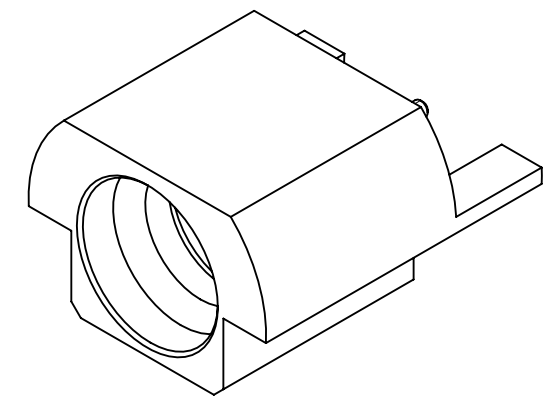

RECOMMENDED PCB LAYOUT
* DIMENSIONS APPLICABLE FOR ROGERS 4350
PCB MATERIAL ONLY

73415-5721	ONE PER BAG
73415-5720	TAPE & REEL
PART NO.	PACKAGING

PS-89675-3320	PRODUCT SPECIFICATION
MIL-STD-348B, FIG. 326.2	SMP FD INTERFACE
SPECIFICATION	DESCRIPTION

B2	2020/6/15	ADD VSWR & IL PER EWR #13859-A
REV	DATE	DESCRIPTION

THIS DRAWING CONTAINS INFORMATION THAT IS PROPRIETARY TO MOLEX ELECTRONIC TECHNOLOGIES, LLC AND SHOULD NOT BE USED WITHOUT WRITTEN PERMISSION									
DIMENSION UNITS		SCALE		CURRENT REV DESC:				molex	
INCH/MM		NTS							
GENERAL TOLERANCES (UNLESS SPECIFIED)				EC NO: 639798				SMP PLUG, PCB EDGEMOUNT	
ANGULAR TOL ± 2.0°				DRWN: RYEH 2020/06/11				FULL DETENT, 50 OHMS EWR-2973, SMP-P/PCB	
4 PLACES ±				CHK'D: YCHENG 2020/07/01				PRODUCT CUSTOMER DRAWING	
3 PLACES ±				APPR: YCHENG 2020/07/01				DOCUMENT NUMBER	
2 PLACES ±				INITIAL REVISION:				DOC TYPE	
1 PLACE ±				DRWN: SSHAH 2006/02/10				DOC PART	
0 PLACES ±				APPR: JWIENER 2006/02/10				REVISION	
DRAFT WHERE APPLICABLE MUST REMAIN WITHIN DIMENSIONS		THIRD ANGLE PROJECTION		DRAWING		SERIES		MATERIAL NUMBER	
				C-SIZE		73415		SEE TABLE	
						HARRIS		1 OF 3	

DOCUMENT STATUS	P1	RELEASE DATE	2020/07/01	06:39:48
-----------------	----	--------------	------------	----------

NOTE:

10 PITCHES CUMULATIVE TOLERANCE ±.008 (0.20)

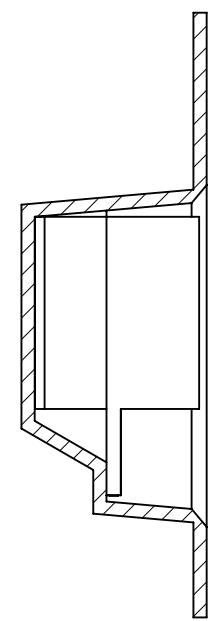

SECTION B-B

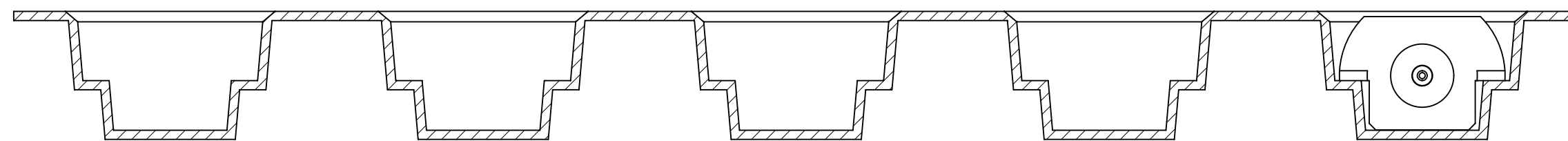
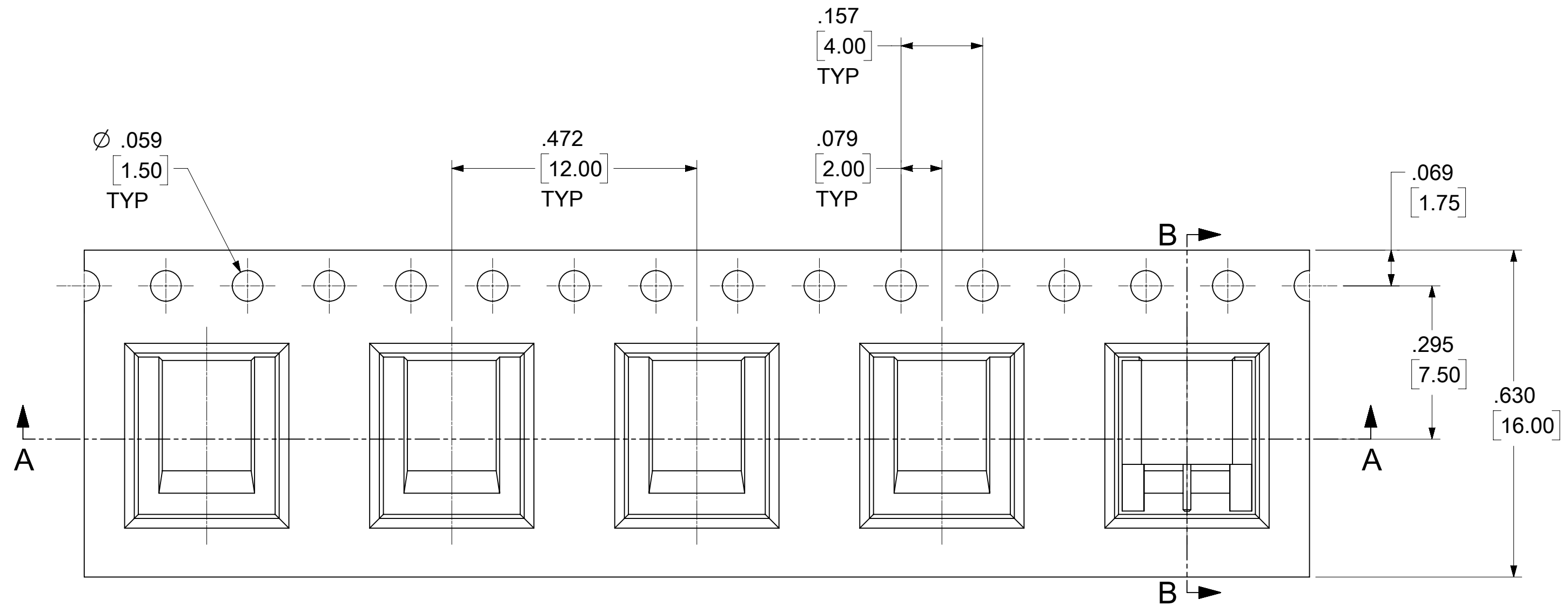

SECTION A-A

THIS DRAWING CONTAINS INFORMATION THAT IS PROPRIETARY TO MOLEX ELECTRONIC TECHNOLOGIES, LLC AND SHOULD NOT BE USED WITHOUT WRITTEN PERMISSION									
DIMENSION UNITS		SCALE		CURRENT REV DESC:				molex	
INCH/MM		NTS							
GENERAL TOLERANCES (UNLESS SPECIFIED)				EC NO: 639798				SMP PLUG, PCB EDGEMOUNT FULL DETENT, 50 OHMS EWR-2973, SMP-P/PCB	
ANGULAR TOL ± 2.0°				DRWN: RYEH 2020/06/11					
4 PLACES ±				CHK'D: YCHENG 2020/07/01				PRODUCT CUSTOMER DRAWING	
3 PLACES ±				APPR: YCHENG 2020/07/01					
2 PLACES ±				INITIAL REVISION:				DOCUMENT NUMBER	
1 PLACE ±				DRWN: SSHAH 2006/02/10					
0 PLACES ±				APPR: JWIENER 2006/02/10				SD-73415-572	
DRAFT WHERE APPLICABLE MUST REMAIN WITHIN DIMENSIONS		THIRD ANGLE PROJECTION		DRAWING		SERIES		MATERIAL NUMBER	
				C-SIZE		73415		SEE TABLE	
CUSTOMER		SHEET NUMBER		DOC TYPE		DOC PART		REVISION	
HARRIS		2 OF 3		PSD		001		B2	

DOCUMENT STATUS	P1	RELEASE DATE	2020/07/01	06:39:48
-----------------	----	--------------	------------	----------

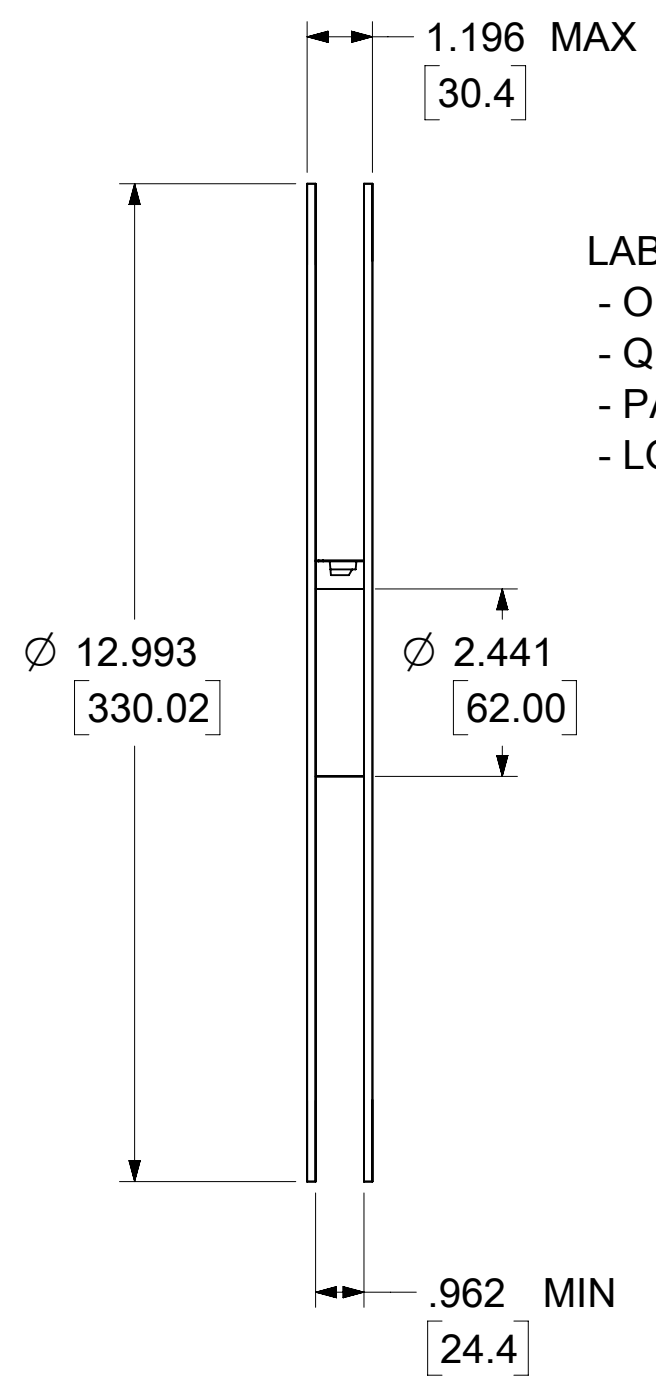

LABEL:
 - ORDER NO.
 - QUANTITY
 - PART NUMBER
 - LOT NO.

Ø .502
 [12.75]

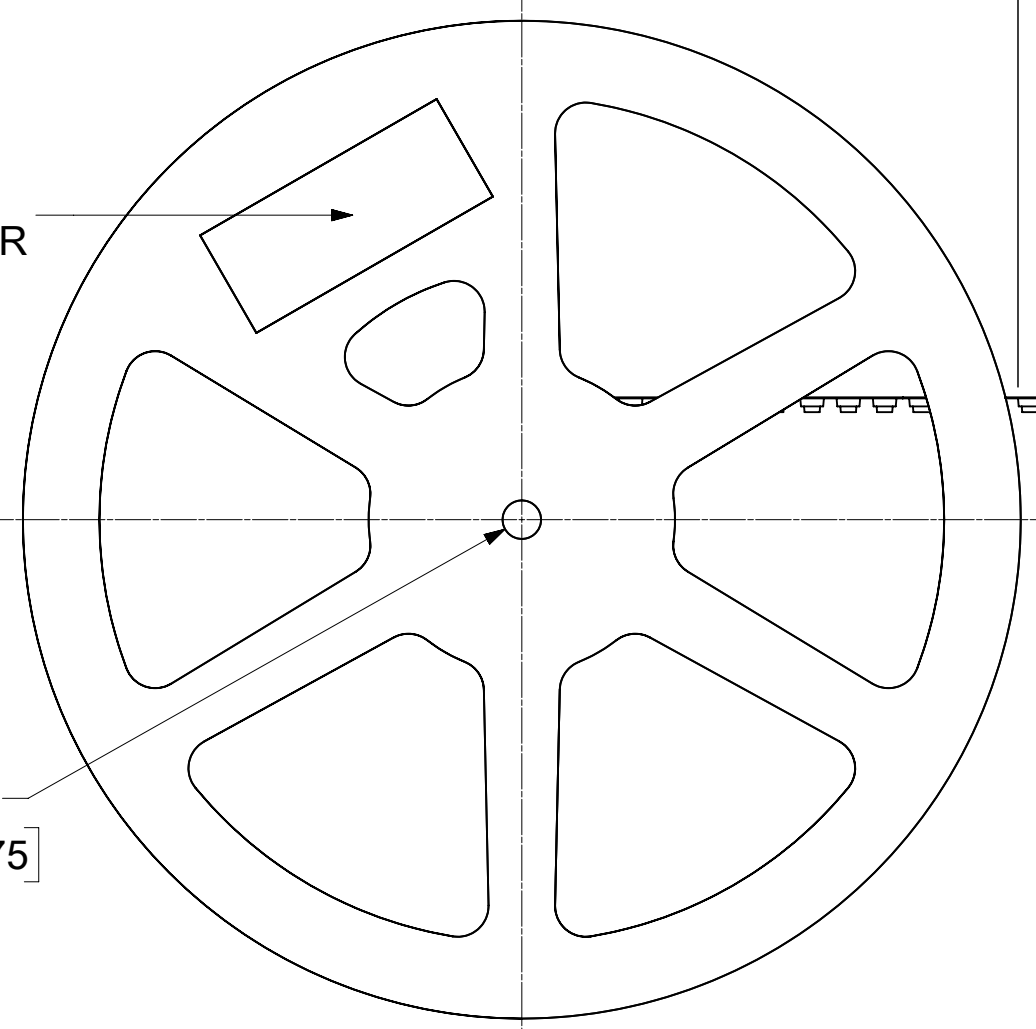

250mm EMPTY UNITS
 MINIMUM

ORDER QUANTITY
 PACKED WITH 1250
 COMPONENTS

250mm EMPTY UNITS
 MINIMUM

.230 MIN
 [5.84]

HANDLING DIRECTION

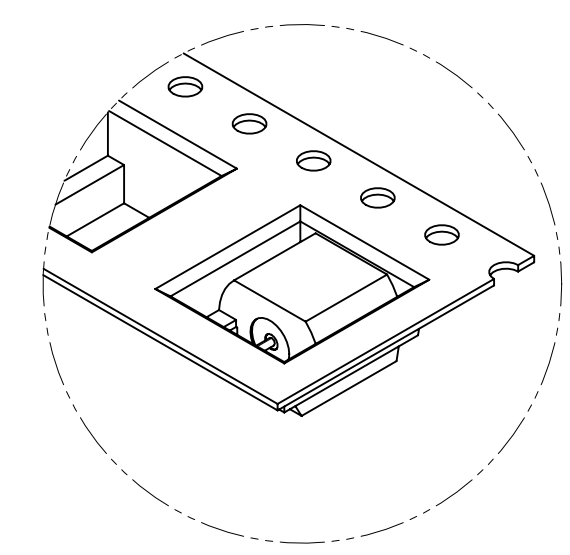
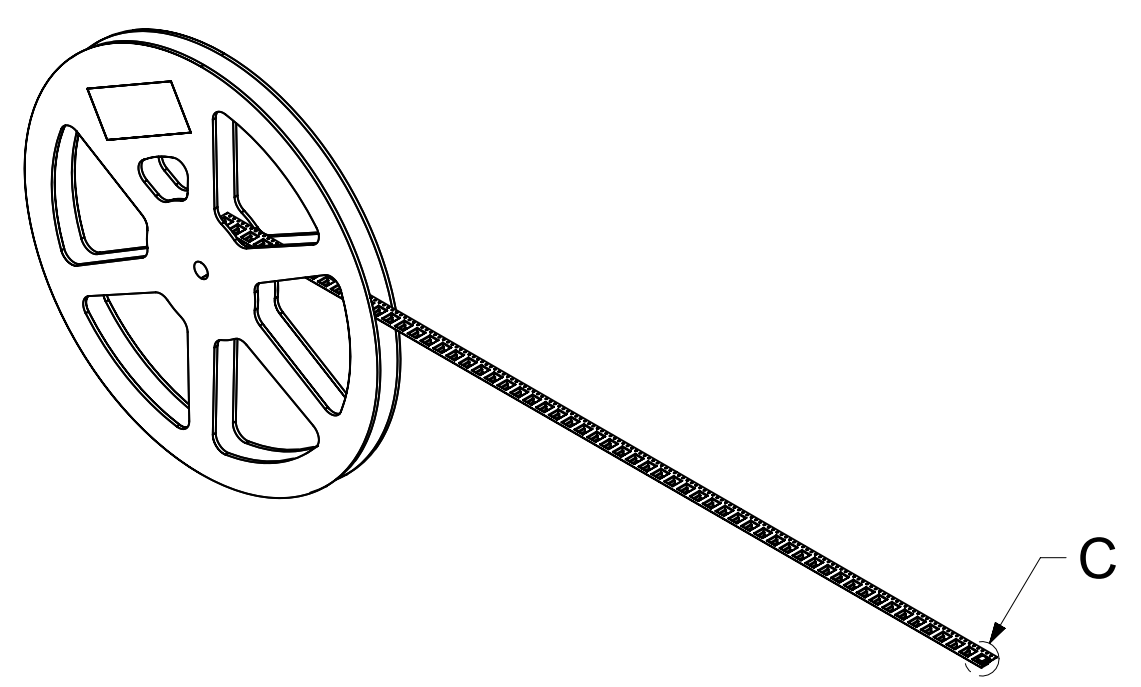

DETAIL C
 SCALE 3:1

THIS DRAWING CONTAINS INFORMATION THAT IS PROPRIETARY TO MOLEX ELECTRONIC TECHNOLOGIES, LLC AND SHOULD NOT BE USED WITHOUT WRITTEN PERMISSION

DIMENSION UNITS		SCALE		CURRENT REV DESC:				molex									
INCH/MM		NTS															
GENERAL TOLERANCES (UNLESS SPECIFIED)						EC NO: 639798				SMP PLUG, PCB EDGEMOUNT FULL DETENT, 50 OHMS EWR-2973, SMP-P/PCB							
ANGULAR TOL ± 2.0°						DRWN: RYEH 2020/06/11											
4 PLACES ±						CHK'D: YCHENG 2020/07/01				PRODUCT CUSTOMER DRAWING							
3 PLACES ±						APPR: YCHENG 2020/07/01											
2 PLACES ±						INITIAL REVISION:				DOCUMENT NUMBER							
1 PLACE ±						DRWN: SSHAH 2006/02/10											
0 PLACES ±						APPR: JWIENER 2006/02/10				SD-73415-572							
DRAFT WHERE APPLICABLE MUST REMAIN WITHIN DIMENSIONS						THIRD ANGLE PROJECTION		DRAWING		SERIES		MATERIAL NUMBER		CUSTOMER		SHEET NUMBER	
								C-SIZE		73415		SEE TABLE		HARRIS		3 OF 3	

DOCUMENT STATUS	P1	RELEASE DATE	2020/07/01	06:39:48
-----------------	----	--------------	------------	----------