

GENERAL TOLERANCE

DIM. RANGE	0.5 - 3	>3-6	>6-30	>30-120	>120-400
TOLERANCE	±0.1	±0.1	±0.2	±0.3	±0.5

CUSTOMER DRAWING



REVISION		
REV.	DESCRIPTION	DATE
C	MODIFY DESIGN	2016-11-23
D	UPDATE RoHS LABEL	2017-03-11
E	UPDATE CODE NUMBER AND MFG NUMBER	2018-06-28
F	ADD BUSBAR TYPE	2018-09-19
G	UPDATE CODE NUMBER	2019-02-21

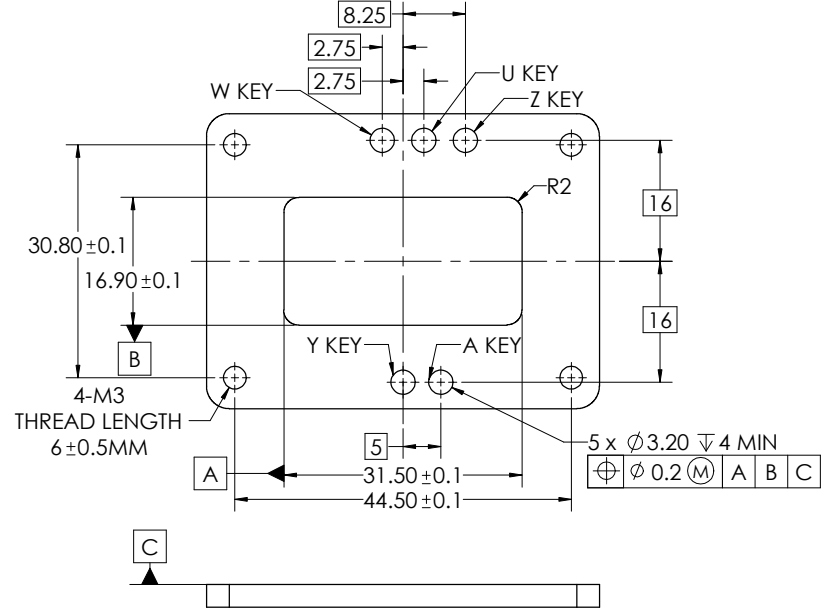
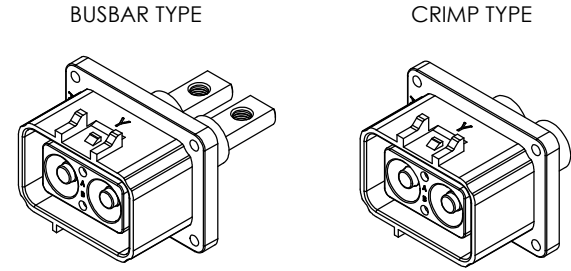
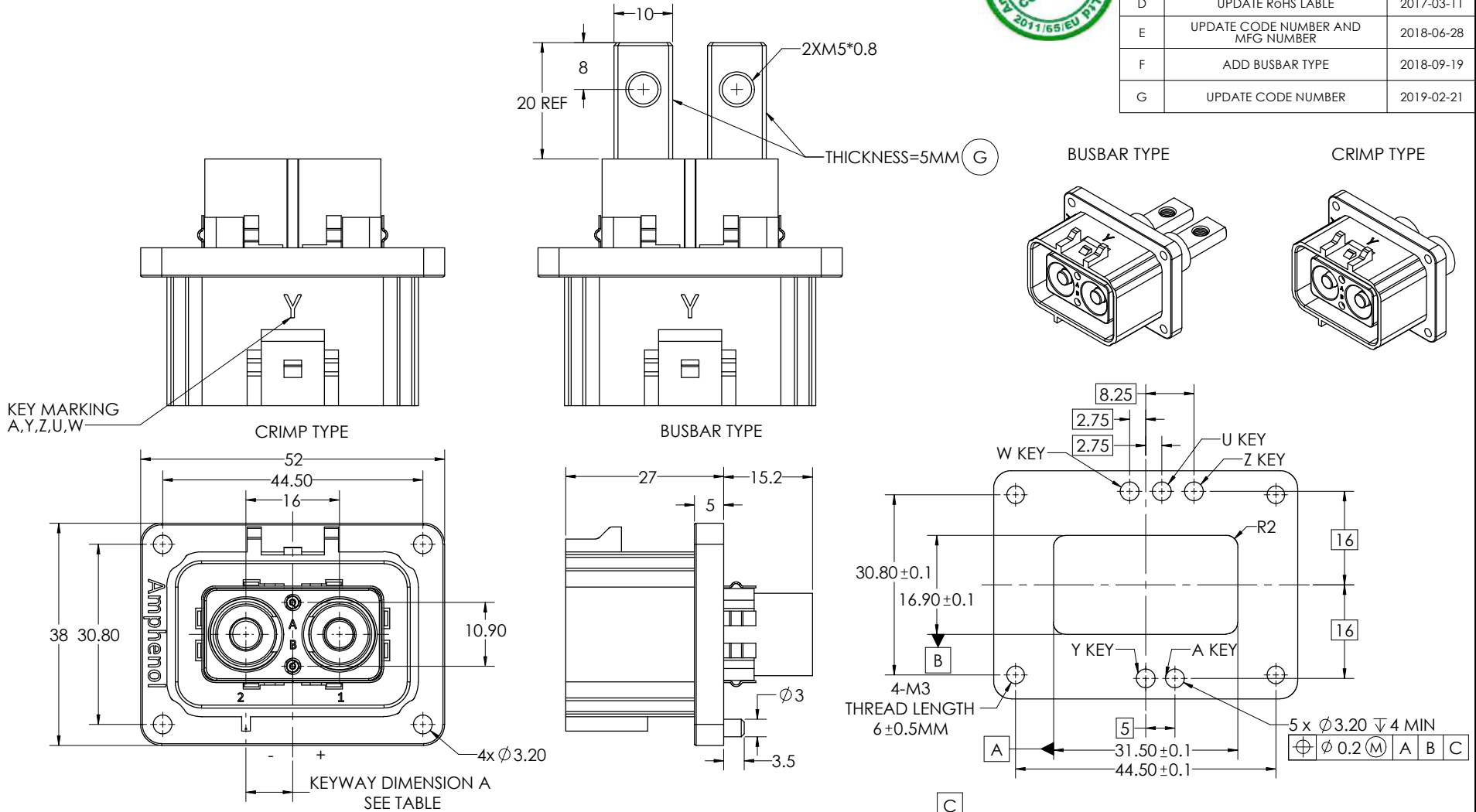

3. FOR ORDERING INFORMATION, PLEASE SEE CODE NUMBER REFERENCE. TO COMPLETE IT, ADD APPLICABLE CHARACTERS FOR DESIRED REQUIREMENT. SEE PAGE 2 FOR DETAIL INFORMATION.

2. THE DRAWING ILLUSTRATE FINALL ASSEMBLY. FOR STORAGE AND SHIPPING, THE POWER &HVIL CONTACTS ARE SHIPPED UNASSEMBLED.

1. THE REFERENCED PRODUCT SHALL BE COMPLIANT TO RoHS DIRECTIVE

NOTES:
THIS DOCUMENT CONTAINS PROPRIETARY INFORMATION AND SUCH INFORMATION MAY NOT BE DISCLOSED TO OTHERS FOR ANY PURPOSE OR USED FOR MANUFACTURING PURPOSES WITHOUT WRITTEN PERMISSION FROM THE AMPHENOL CORP.

UNLESS OTHERWISE SPECIFIED	APPROVALS		DATE
LINEAR DIMENSIONS ARE IN: MILLIMETERS TOLERANCES: ANGLES=±2° DEFAULT LINEAR TOLERANCES SEE TABLE	PREPARED BY:	THOR YAN	2019-02-21
DIM. & TOL. PER ASME Y14.5M-1994; DRM PER MIL-DTL-31000; OTHER AMPHENOL STANDARDS: 9-3800	ENGINEER IN CHANGE:	SEVEN XIE	
	DESIGN MANAGER:	ROB WENG	
	PRODUCT GROUP:	C&3	
LEGENDS: =FLAG NOTE CALL OUT REFERENCE THIRD ANGLE PROJECTION	MATERIAL SPEC	PROCESS SPEC	
	N/A	N/A	

AMPHENOL INDUSTRIAL OPERATIONS			
Amphenol Technology (Zhuhai) Co., Ltd No.63, Xingnan Road, Sanzao Town, Jinwan, Zhuhai, PRC			
ELECTRICAL RECEPTACLE CONNECTOR			
WITH HVIL & SHIELDING			
2PORTS, Epower-lite SERIES			
SIZE	CAGE CODE	DOCUMENT NUMBER	REV
C	77820	C ()-738985-2 () P ()	G
SCALE: 2:1	REF:	N/A	SHEET 1 OF 2

CODE NUMBER REFERANCE: ELRA2() () () G

KEYWAY MARKING
SEE TABLE 1

PIN TYPE
SEE TABLE 1

HVIL&EMI OPTION
SEE TABLE 1

MFG NUMBER REFERANCE: C () -738985-2 () P ()

HVIL&EMI OPTION
SEE TABLE 2

KEYWAY MARKING
SEE TABLE 2

PIN TYPE
SEE TABLE 2

SEPCIFICATION	
CONTACT SIZE	5.7 MM (RADSOK CONTACT) / #20 (HVIL CONTACT)
CONTACT TEST CURRENT	POWER 120 Amps Max HVIL 5 Amps
OPERATING VOLTAGE	600V AC
OPERATING TEMPERATRUE	-40°C TO 125°C
DIELECTRIC WITHATANDING VOLTAGE	2500V AC
NUMBER OF CANTACT	2&2
DURABILITY	100 (MIN)
WATER PROOF	IP67 (MATED)
FINGER PROOF	YES
HVIL	OPTION
SALT SPRAY	96 H

TABLE 1			
ITEM NO.	DESCRIPTION	CODE NUMBER	DIMENSION A
KEYWAY MARKING	KEYWAY A	A	-4
	KEYWAY Y	Y	-8
	KEYWAY Z	Z	0
	KEYWAY U	U	8
	KEYWAY W	W	4
PIN TYPE	25 MM^2 CRIMP		25
	16 MM^2 CRIMP		16
	BUSBAR		03
HVIL & EMI OPTION	YES EMI & YES HVIL		--
	YES EMI & NO HVIL		01
	NO EMI & YES HVIL		10
	NO EMI & NO HVIL		11

TABLE 2			
ITEM NO.	DESCRIPTION	MFG NUMBER	DIMENSION A
KEYWAY MARKING	KEYWAY A	A	-4
	KEYWAY Y	Y	-8
	KEYWAY Z	Z	0
	KEYWAY U	U	8
	KEYWAY W	W	4
PIN TYPE	BUSBAR		3
	25 MM^2		2
	16 MM^2		1
HVIL & EMI OPTION	YES EMI & YES HVIL		10
	YES EMI & NO HVIL		20
	NO EMI & YES HVIL		30
	NO EMI & NO HVIL		40

NOTES:

THIS DOCUMENT CONTAINS PROPRIETARY INFORMATION AND SUCH INFORMATION MAY NOT BE DISCLOSED TO OTHERS FOR ANY PURPOSE OR USED FOR MANUFACTURING PURPOSES WITHOUT WRITTEN PERMISSION FROM THE AMPHENOL CORP.

SIZE	CAGE CODE	DOCUMENT NUMBER	REV
C	77820	C () -738985-2 () P ()	G
SCALE: 2:1	REF:	N/A	SHEET 2 OF 2