

0.472 [12.00]
+0.004 -0.000
[+0.10 -0.00]

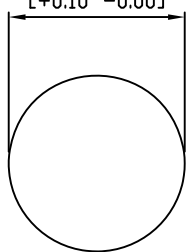

PANEL CUT-OUT

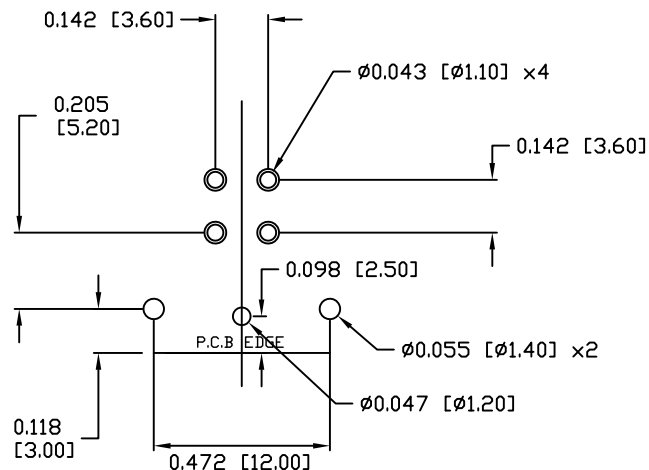

P.C.B. LAYOUT

NOTE:

MATERIAL

HOUSING: PBT UL94V-0, BLACK
CONTACT: BRASS
NUT: BRASS
O-RING: EPDM, BLACK
BACK HOUSING: PBT, UL94V-0, BLACK
DOWN HOUSING: PBT, UL94V-0, BLACK

FINISH

CONTACT: GOLD PLATED
OVER 50 μ " NICKEL
NUT: NICKEL PLATED
60 μ " TO 100 μ "
SHELL: NICKEL PLATED
60 μ " TO 100 μ "

ELECTRICAL

RATED CURRENT: 4A
RATED VOLTAGE: 250V
INSULATION RESISTANCE: 100 M Ω hms MIN.
CONTACT RESISTANCE: 10 m Ω hms MAX.
WATER PROOF: IP67
ENVIRONMENT
OPERATION TEMPERATURE: -40°C TO +85°C

861-D04-113R00Y

3 = BRASS/NICKEL SHELL & NUT
S = STAINLESS STEEL SHELL & NUT

1 = GOLD FLASH
4 = 10 μ " GOLD

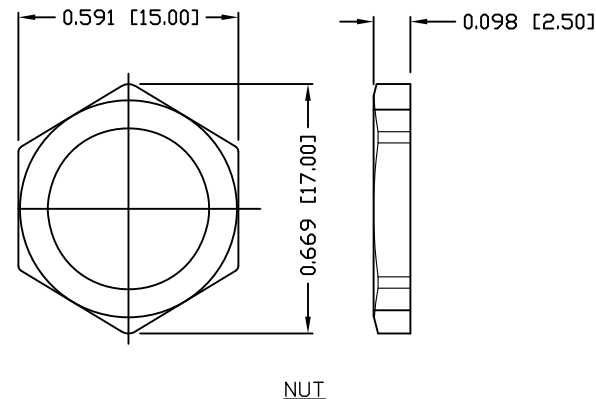
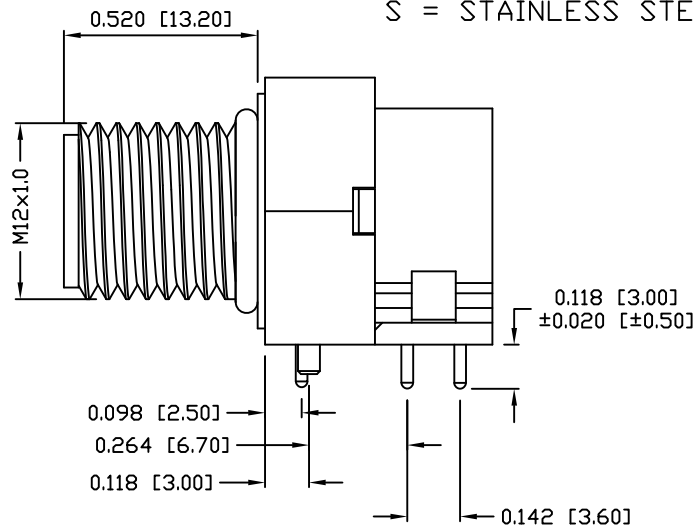
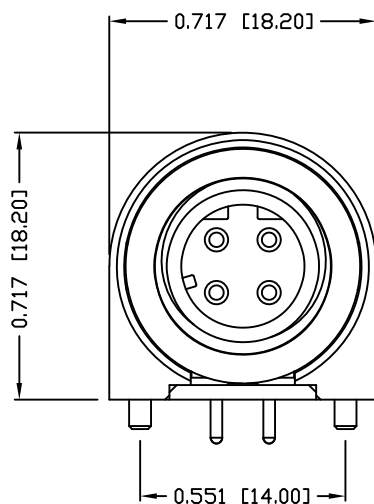

NUT

RoHS COMPLIANT

UNITS = INCHES [MM]

DO NOT SCALE FROM DRAWING



THESE DRAWINGS AND SPECIFICATIONS ARE THE PROPERTY OF NorComp AND SHALL NOT BE REPRODUCED, COPIED OR USED AS THE BASIS FOR THE MANUFACTURE OR SALE OF APPARATUS WITHOUT WRITTEN PERMISSION.

DRAWN:

M. SIGMON

DATE:

07-26-16

NorComp

SCALE:

NTS

SHEET

1

OF

1

REV

2

DWG NO.

861-D04-113R00Y