

## 8K x 8 Registered PROM

### Features

- CMOS for optimum speed/power
- High speed (Commercial)
  - 15 ns address set-up
  - 12 ns clock to output
- Low power
  - 660 mW (Commercial)
- On-chip edge-triggered registers
  - Ideal for pipelined microprogrammed systems
- EPROM technology
  - 100% programmable
  - Reprogrammable (CY7C265W)
- 5V  $\pm 10\%$   $V_{CC}$ , commercial and military
- Capable of withstanding >2001V static discharge
- Slim 28-pin, 300-mil plastic or hermetic DIP

### Functional Description

The CY7C265 is a 8192 x 8 registered PROM. It is organized as 8,192 words by 8 bits wide, and has a pipeline output register. In addition, the device features a programmable initialize byte that may be loaded into the pipeline register with the initialize signal. The programmable initialize byte is the 8,193rd byte in the PROM and its value is programmed at the time of use.

Packaged in 28 pins, the PROM has 13 address signals ( $A_0$  through  $A_{12}$ ), 8 data out signals ( $O_0$  through  $O_7$ ),  $\bar{E}/I$  (enable or initialize), and CLOCK.

CLOCK functions as a pipeline clock, loading the contents of the addressed memory location into the pipeline register on each rising edge. The data will appear on the outputs if they

are enabled. One pin on the CY7C265 is programmed to perform either the enable or the initialize function.

If the asynchronous enable ( $\bar{E}$ ) is being used, the outputs may be disabled at any time by switching the enable to a logic HIGH, and may be returned to the active state by switching the enable to a logic LOW.

If the synchronous enable ( $\bar{E}_S$ ) is being used, the outputs will go to the OFF or high-impedance state upon the next positive clock edge after the synchronous enable input is switched to a HIGH level. If the synchronous enable pin is switched to a logic LOW, the subsequent positive clock edge will return the output to the active state. Following a positive clock edge, the address and synchronous enable inputs are free to change since no change in the output will occur until the next LOW-to-HIGH transition of the clock. This unique feature allows the CY7C265 decoders and sense amplifiers to access the next location while previously addressed data remains stable on the outputs.

If the  $\bar{E}/I$  pin is used for  $\bar{INIT}$  (asynchronous), then the outputs are permanently enabled. The initialize function is useful during power-up and time-out sequences, and can facilitate implementation of other sophisticated functions such as a built-in "jump start" address. When activated, the initialize control input causes the contents of a user programmed 8193rd 8-bit word to be loaded into the on-chip register. Each bit is programmable and the initialize function can be used to load any desired combination of 1's and 0's into the register. In the unprogrammed state, activating  $\bar{INIT}$  will generate a register clear (all outputs LOW). If all the bits of the initialize word are programmed to be a 1, activating  $\bar{INIT}$  performs a register preset (all outputs HIGH).

Applying a LOW to the  $\bar{INIT}$  input causes an immediate load of the programmed initialize word into the pipeline register and onto the outputs. The  $\bar{INIT}$  LOW disables clock and must return HIGH to enable clock independent of all other inputs, including the clock.

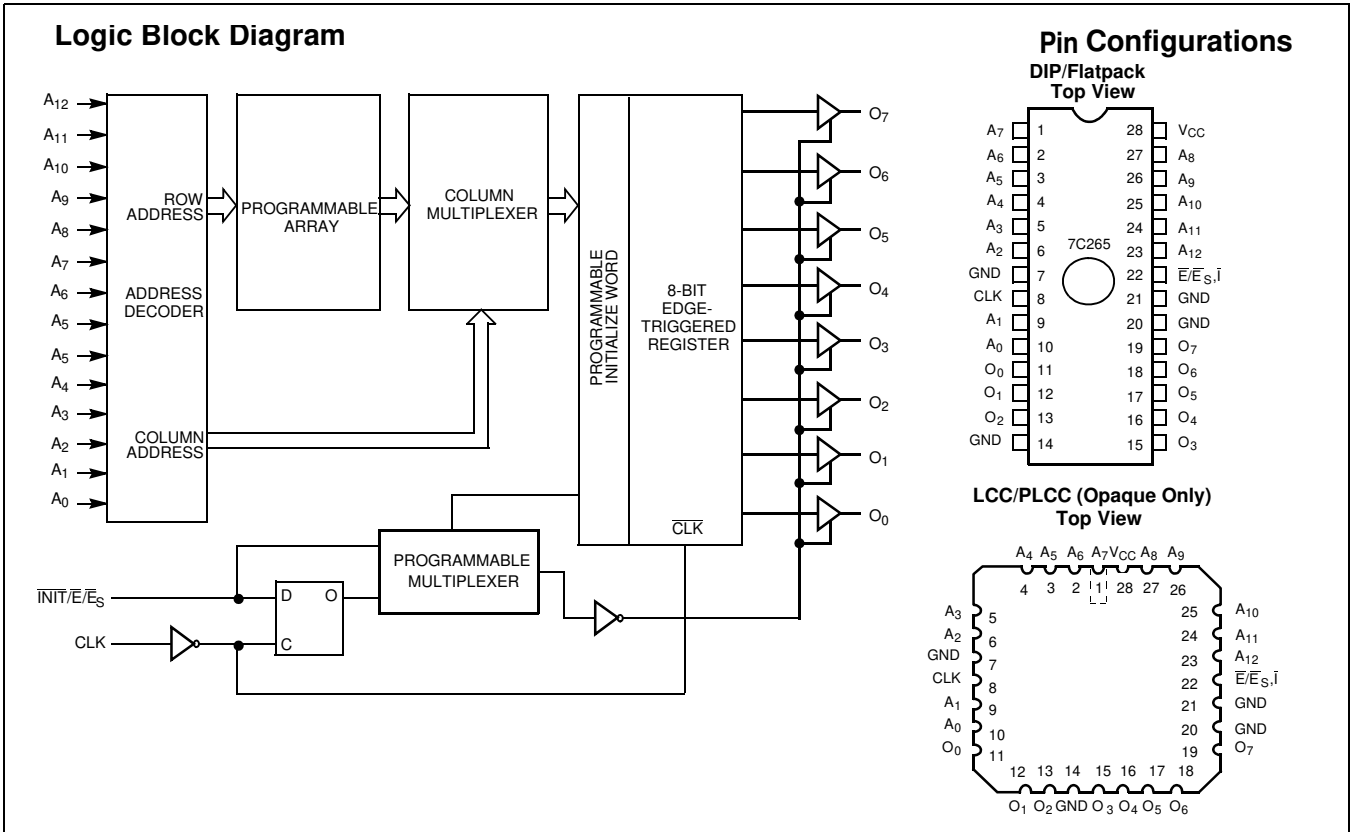

**Selection Guides**

		7C265-15	7C265-25	7C265-40	7C265-50	Unit
Minimum Address Set-Up Time		15	25	40	50	ns
Maximum Clock to Output		12	15	20	25	ns
Maximum Operating Current	Com'l	120	120	100		mA
	Mil				120	mA

**Maximum Ratings**

(Above which the useful life may be impaired. For user guidelines, not tested.)

- Storage Temperature .....-65°C to +150°C
- Ambient Temperature with Power Applied .....-55°C to +125°C
- Supply Voltage to Ground Potential .....-0.5V to +7.0V
- DC Voltage Applied to Outputs in High Z State .....-0.5V to +7.0V
- DC Input Voltage .....-3.0V to +7.0V

- DC Program Voltage..... 13.0V
- UV Exposure ..... 7258 Wsec/cm<sup>2</sup>
- Static Discharge Voltage..... >2001V (per MIL-STD-883, Method 3015)
- Latch-Up Current..... >200 mA

**Operating Range**

Range	Ambient Temperature	V <sub>CC</sub>
Commercial	0°C to +70°C	5V ±10%
Military <sup>[1]</sup>	-55°C to +125°C	5V ±10%

**Note**

1. T<sub>A</sub> is the "instant on" case temperature.

**Electrical Characteristics** Over the Operating Range<sup>[2]</sup>

Parameter	Description	Test Conditions	7C265-15, 25		7C265-40		7C265-50		Unit
			Min.	Max.	Min.	Max.	Min.	Max.	
V <sub>OH</sub>	Output HIGH Voltage	V <sub>CC</sub> = Min., I <sub>OH</sub> = -2.0 mA	2.4						V
		V <sub>CC</sub> = Min., I <sub>OH</sub> = -4.0 mA			2.4		2.4		
V <sub>OL</sub>	Output LOW Voltage	V <sub>CC</sub> = Min., I <sub>OL</sub> = 8.0 mA	Com'l	0.4					V
		V <sub>CC</sub> = Min., I <sub>OL</sub> = 12.0 mA				0.4		0.4	
		V <sub>CC</sub> = Min., I <sub>OL</sub> = 6.0 mA	Mil	0.4					
		V <sub>CC</sub> = Min., I <sub>OL</sub> = 8.0 mA						0.4	
V <sub>IH</sub>	Input HIGH Voltage		2.0		2.0		2.0	V	
V <sub>IL</sub>	Input LOW Voltage			0.8		0.8		0.8	V
I <sub>IX</sub>	Input Load Current	GND ≤ V <sub>IN</sub> ≤ V <sub>CC</sub>	-10	+10	-10	+10	-10	+10	μA
I <sub>OZ</sub>	Output Leakage Current	GND ≤ V <sub>OUT</sub> ≤ V <sub>CC</sub> , Output Disabled	-40	+40	-40	+40	-40	+40	μA
I <sub>OS</sub> <sup>[3]</sup>	Output Short Circuit Current	V <sub>CC</sub> = Max., V <sub>OUT</sub> = GND		90		90		90	mA
I <sub>CC</sub>	V <sub>CC</sub> Operating Supply Current	V <sub>CC</sub> = Max., I <sub>OUT</sub> = 0 mA	Com'l	120		100			mA
			Mil					120	
V <sub>PP</sub>	Programming Supply Voltage		12	13	12	13	12	13	V
I <sub>PP</sub>	Programming Supply Current			50		50		50	mA
V <sub>IHP</sub>	Input HIGH Programming Voltage		3.0		3.0		3.0		V
V <sub>ILP</sub>	Input LOW Programming Voltage			0.4		0.4		0.4	V

**Capacitance**<sup>[4]</sup>

Parameter	Description	Test Conditions	Max.	Unit
C <sub>IN</sub>	Input Capacitance	T <sub>A</sub> = 25°C, f = 1 MHz, V <sub>CC</sub> = 5.0V	10	pF
C <sub>OUT</sub>	Output Capacitance		10	pF

**Notes**

2. See the last page of this specification for Group A subgroup testing information.
3. For test purposes, not more than one output at a time should be shorted. Short circuit test duration should not exceed 30 seconds.
4. See Introduction to CMOS PROMs in this Data Book for general information on testing.

## AC Test Loads and Waveforms

### Test Load for -15 through -25 speeds

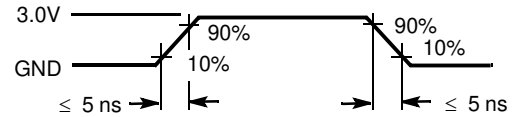
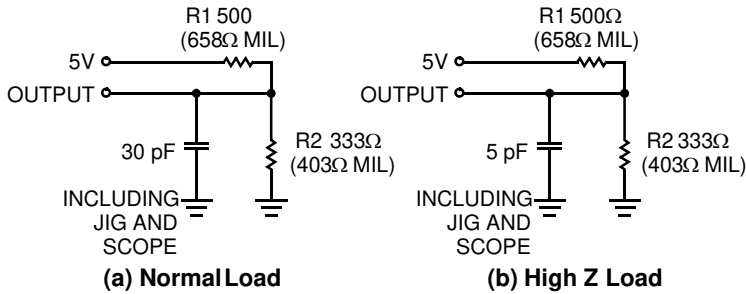

Equivalent to: THÉVENIN EQUIVALENT



### Test Load for -40 through -50 speeds

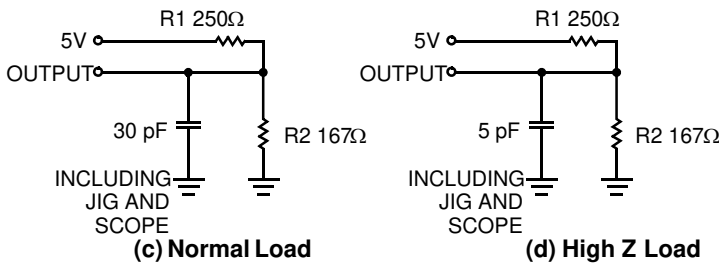

Equivalent to: THÉVENIN EQUIVALENT



## Switching Characteristics Over the Operating Range<sup>[2, 4]</sup>

Parameter	Description	7C265-15		7C265-25		7C265-40		7C265-50		Unit
		Min.	Max.	Min.	Max.	Min.	Max.	Min.	Max.	
t <sub>AS</sub>	Address Set-Up to Clock	15		25		40		50		ns
t <sub>HA</sub>	Address Hold from Clock	0		0		0		0		ns
t <sub>CO</sub>	Clock to Output Valid		12		15		20		25	ns
t <sub>PWC</sub>	Clock Pulse Width	12		15		15		20		ns
t <sub>SES</sub>	E <sub>S</sub> Set-Up to Clock (Sync. Enable Only)	12		15		15		15		ns
t <sub>HES</sub>	E <sub>S</sub> Hold from Clock	5		5		5		5		ns
t <sub>DI</sub>	INIT to Output Valid		15		18		25		35	ns
t <sub>RI</sub>	INIT Recovery to Clock	12		15		20		25		ns
t <sub>PWI</sub>	INIT Pulse Width	12		15		25		35		ns
t <sub>COs</sub>	Output Valid from Clock (Sync. Mode)		12		15		20		25	ns
t <sub>HZC</sub>	Output Inactive from Clock (Sync. Mode)		12		15		20		25	ns
t <sub>DOE</sub>	Output Valid from E LOW (Async. Mode)		12		15		20		25	ns

**Switching Characteristics** Over the Operating Range<sup>[2, 4]</sup> (continued)

Parameter	Description	7C265-15		7C265-25		7C265-40		7C265-50		Unit
		Min.	Max.	Min.	Max.	Min.	Max.	Min.	Max.	
t <sub>HZE</sub>	Output Inactive from E HIGH (Async. Mode)		12		15		20		25	ns

**Switching Waveform**

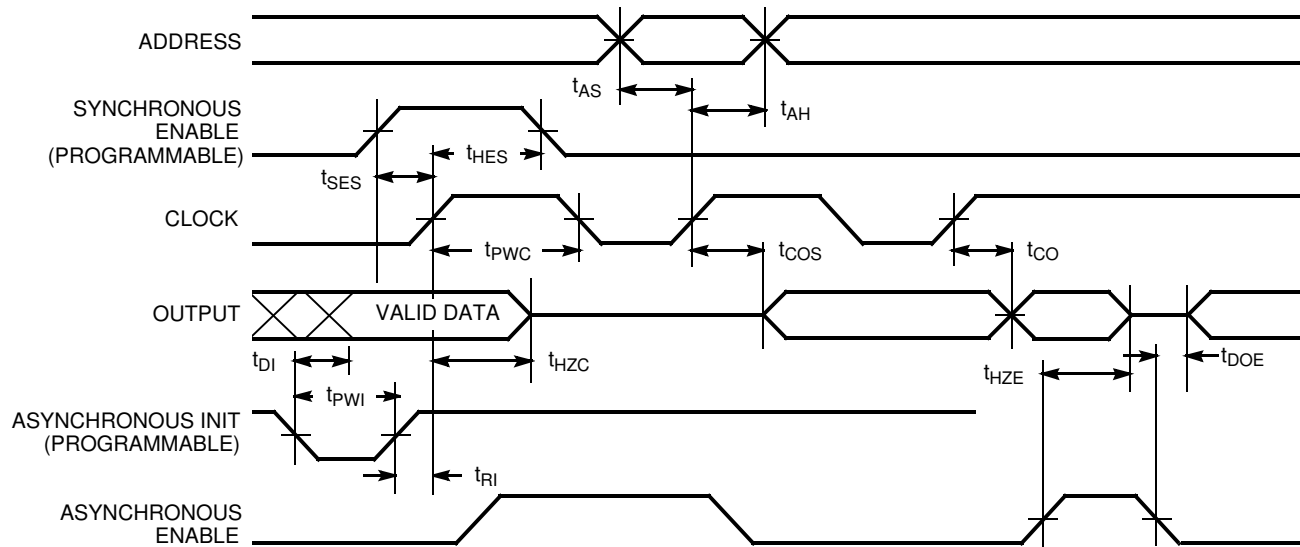

**Erasure Characteristics**

Wavelengths of light less than 4000 angstroms begin to erase the 7C265 in the windowed package. For this reason, an opaque label should be placed over the window if the PROM is exposed to sunlight or fluorescent lighting for extended periods of time.

The recommended dose of ultraviolet light for erasure is a wavelength of 2537 angstroms for a minimum dose (UV intensity • exposure time) of 25 Wsec/cm<sup>2</sup>. For an ultraviolet lamp with a 12 mW/cm<sup>2</sup> power rating the exposure time would be approximately 45 minutes. The 7C265 needs to be within one inch of the lamp during erasure. Permanent damage may result if the PROM is exposed to high-intensity UV light for an extended period of time. 7258 Wsec/cm<sup>2</sup> is the recommended maximum dosage.

**Bit Map Data**

Programmer Address (Hex.)		RAM Data
Decimal	Hex	Contents

**Bit Map Data**

0	0	Data
.	.	.
8191	1FFF	Data
8192	2000	INIT Byte
8193	2001	Control Byte

**Control Byte**

- 00 Asynchronous output enable (default condition)
- 01 Synchronous output enable
- 02 Asynchronous initialize

**Programming Modes**

The 7C265 offers a limited selection of programmed architectures. Programming these features should be done with a single 10-ms-wide pulse in place of the intelligent algorithm, mainly because these features are verified operationally, not with the VFY pin. Architecture programming is implemented by applying the supervoltage to two additional pins during programming. In programming the 7C265 architecture, VPP is applied to pins 3, 9, and 22. The choice of a particular mode depends on the states of the other pins during programming, so it is important that the condition of the other pins be met as set forth in the mode table. The considerations that apply with

respect to power-up and power-down during intelligent programming also apply during architecture programming. Once the supervoltages have been established and the correct logic states exist on the other device pins,

programming may begin. Programming is accomplished by pulling PGM from HIGH to LOW and then back to HIGH with a pulse width equal to 10 ms.

**Table 1. Mode Selection**

Mode	Pin Function							
	Read or Output Disable	A <sub>12</sub>	A <sub>11</sub>	A <sub>10</sub> -A <sub>7</sub>	A <sub>6</sub>	A <sub>5</sub>	A <sub>4</sub> -A <sub>3</sub>	A <sub>2</sub>
	Other	A <sub>12</sub>	A <sub>11</sub>	A <sub>10</sub> -A <sub>7</sub>	A <sub>6</sub>	A <sub>5</sub>	A <sub>4</sub> -A <sub>3</sub>	A <sub>2</sub>
Asynchronous Enable Read		A <sub>12</sub>	A <sub>11</sub>	A <sub>10</sub> -A <sub>7</sub>	A <sub>6</sub>	A <sub>5</sub>	A <sub>4</sub> -A <sub>3</sub>	A <sub>2</sub>
Synchronous Enable Read		A <sub>12</sub>	A <sub>11</sub>	A <sub>10</sub> -A <sub>7</sub>	A <sub>6</sub>	A <sub>5</sub>	A <sub>4</sub> -A <sub>3</sub>	A <sub>2</sub>
Asynchronous Initialization Read		A <sub>12</sub>	A <sub>11</sub>	A <sub>10</sub> -A <sub>7</sub>	A <sub>6</sub>	A <sub>5</sub>	A <sub>4</sub> -A <sub>3</sub>	A <sub>2</sub>
Program Memory		A <sub>12</sub>	A <sub>11</sub>	A <sub>10</sub> -A <sub>7</sub>	A <sub>6</sub>	A <sub>5</sub>	A <sub>4</sub> -A <sub>3</sub>	A <sub>2</sub>
Program Verify		A <sub>12</sub>	A <sub>11</sub>	A <sub>10</sub> -A <sub>7</sub>	A <sub>6</sub>	A <sub>5</sub>	A <sub>4</sub> -A <sub>3</sub>	A <sub>2</sub>
Program Inhibit		A <sub>12</sub>	A <sub>11</sub>	A <sub>10</sub> -A <sub>7</sub>	A <sub>6</sub>	A <sub>5</sub>	A <sub>4</sub> -A <sub>3</sub>	A <sub>2</sub>
Program Synchronous Enable		V <sub>IHP</sub>	V <sub>IHP</sub>	A <sub>10</sub> -A <sub>7</sub>	V <sub>IHP</sub>	V <sub>PP</sub>	A <sub>4</sub> -A <sub>3</sub>	V <sub>IHP</sub>
Program Initialize		V <sub>ILP</sub>	V <sub>IHP</sub>	A <sub>10</sub> -A <sub>7</sub>	V <sub>IHP</sub>	V <sub>PP</sub>	A <sub>4</sub> -A <sub>3</sub>	V <sub>ILP</sub>
Program Initial Byte		A <sub>12</sub>	V <sub>ILP</sub>	A <sub>10</sub> -A <sub>7</sub>	V <sub>IHP</sub>	V <sub>PP</sub>	A <sub>4</sub> -A <sub>3</sub>	V <sub>ILP</sub>

Mode	Pin Function							
	Read or Output Disable	A <sub>1</sub>	A <sub>0</sub>	GND	CLK	GND	$\bar{E}, \bar{I}$	O <sub>7</sub> -O <sub>0</sub>
	Other	A <sub>1</sub>	A <sub>0</sub>	PGM	CLK	V <sub>FY</sub>	V <sub>PP</sub>	D <sub>7</sub> -D <sub>0</sub>
Asynchronous Enable Read		A <sub>1</sub>	A <sub>0</sub>	GND	V <sub>IL</sub>	GND	V <sub>IL</sub>	O <sub>7</sub> -O <sub>0</sub>
Synchronous Enable Read		A <sub>1</sub>	A <sub>0</sub>	GND	V <sub>IL</sub> /V <sub>IH</sub>	GND	V <sub>IL</sub>	O <sub>7</sub> -O <sub>0</sub>
Asynchronous Initialization Read		A <sub>1</sub>	A <sub>0</sub>	GND	V <sub>IL</sub>	GND	V <sub>IL</sub>	O <sub>7</sub> -O <sub>0</sub>
Program Memory		A <sub>1</sub>	A <sub>0</sub>	V <sub>ILP</sub>	V <sub>ILP</sub>	V <sub>IHP</sub>	V <sub>PP</sub>	D <sub>7</sub> -D <sub>0</sub>
Program Verify		A <sub>1</sub>	A <sub>0</sub>	V <sub>IHP</sub>	V <sub>ILP</sub>	V <sub>ILP</sub>	V <sub>PP</sub>	O <sub>7</sub> -O <sub>0</sub>
Program Inhibit		A <sub>1</sub>	A <sub>0</sub>	V <sub>IHP</sub>	V <sub>ILP</sub>	V <sub>IHP</sub>	V <sub>PP</sub>	High Z
Program Synchronous Enable		V <sub>PP</sub>	V <sub>ILP</sub>	V <sub>ILP</sub>	V <sub>ILP</sub>	V <sub>IHP</sub>	V <sub>PP</sub>	D <sub>7</sub> -D <sub>0</sub>
Program Initialize		V <sub>PP</sub>	V <sub>ILP</sub>	V <sub>ILP</sub>	V <sub>ILP</sub>	V <sub>IHP</sub>	V <sub>PP</sub>	D <sub>7</sub> -D <sub>0</sub>
Program Initial Byte		V <sub>PP</sub>	V <sub>IHP</sub>	V <sub>ILP</sub>	V <sub>ILP</sub>	V <sub>IHP</sub>	V <sub>PP</sub>	D <sub>7</sub> -D <sub>0</sub>

**Figure 1. Programming Pinout**

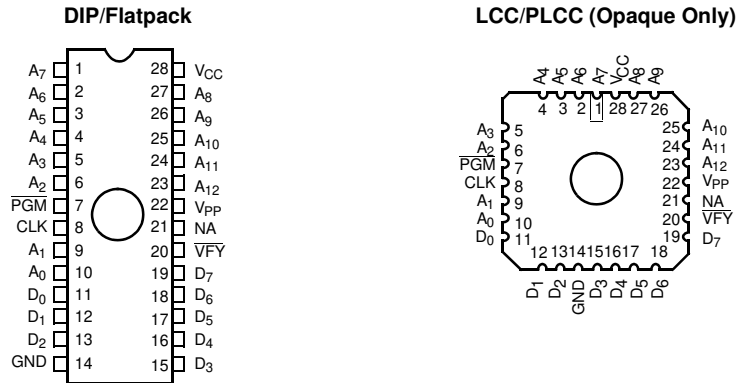

**Programming Information**

Programming support is available from Cypress as well as from a number of third-party software vendors. For detailed

programming information, including a listing of software packages, please see the PROM Programming Information located at the end of this section. Programming algorithms can be obtained from any Cypress representative.

Typical DC and AC Characteristics

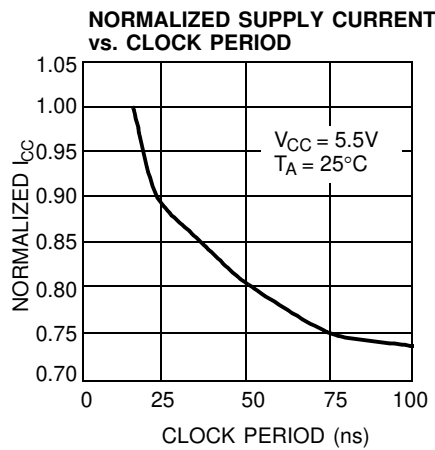
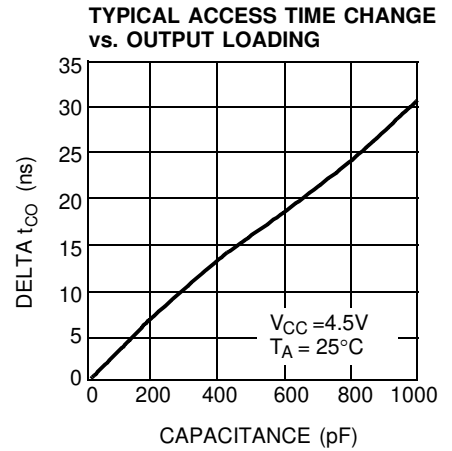
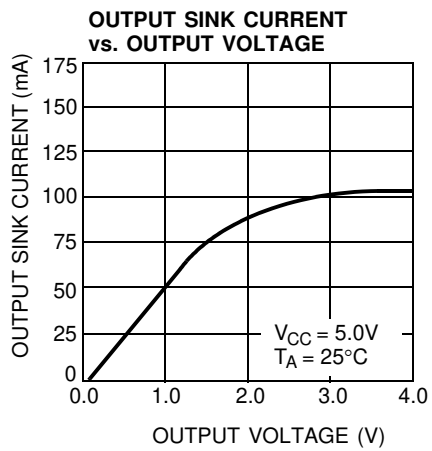
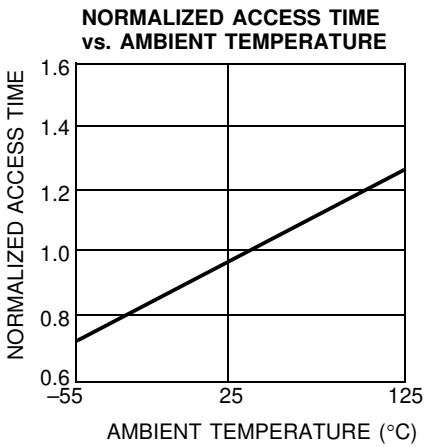
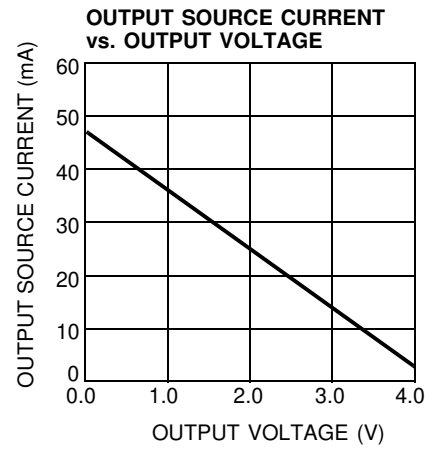
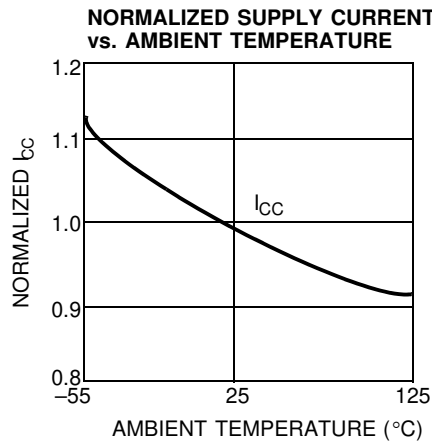
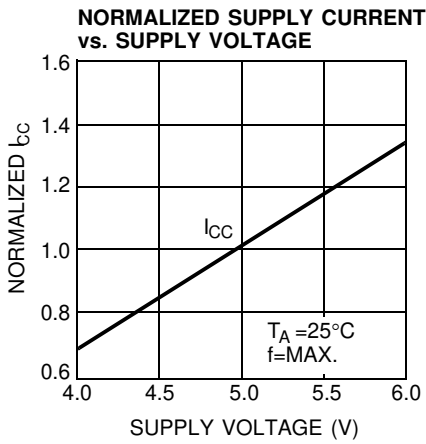



**Ordering Information**

Speed (ns)	I <sub>CC</sub> (mA)	Ordering Code	Package Name	Package Type	Operating Range
15	120	CY7C265-15JC	J64	28-Lead Plastic Leaded Chip Carrier	Commercial
		CY7C265-15WC	W22	28-Lead (300-Mil) Windowed CerDIP	
25	120	CY7C265-25WC	W22	28-Lead (300-Mil) Windowed CerDIP	Commercial
40	100	CY7C265-40PC	P21	28-Lead (300-Mil) Molded DIP	Commercial

**MILITARY SPECIFICATIONS**

**Group A Subgroup Testing**

**DC Characteristics**

Parameter	Subgroups
V <sub>OH</sub>	1, 2, 3
V <sub>OL</sub>	1, 2, 3
V <sub>IH</sub>	1, 2, 3
V <sub>IL</sub>	1, 2, 3
I <sub>IX</sub>	1, 2, 3
I <sub>OZ</sub>	1, 2, 3
I <sub>CC</sub>	1, 2, 3

**Switching Characteristics**

Parameter	Subgroups
t <sub>AS</sub>	7, 8, 9, 10, 11
t <sub>HA</sub>	7, 8, 9, 10, 11
t <sub>CO</sub>	7, 8, 9, 10, 11
t <sub>PW</sub>	7, 8, 9, 10, 11
t <sub>SES</sub>	7, 8, 9, 10, 11
t <sub>HES</sub>	7, 8, 9, 10, 11
t <sub>COS</sub>	7, 8, 9, 10, 11

Package Diagrams

Figure 2. 28-Lead (300-Mil) CerDIP D22

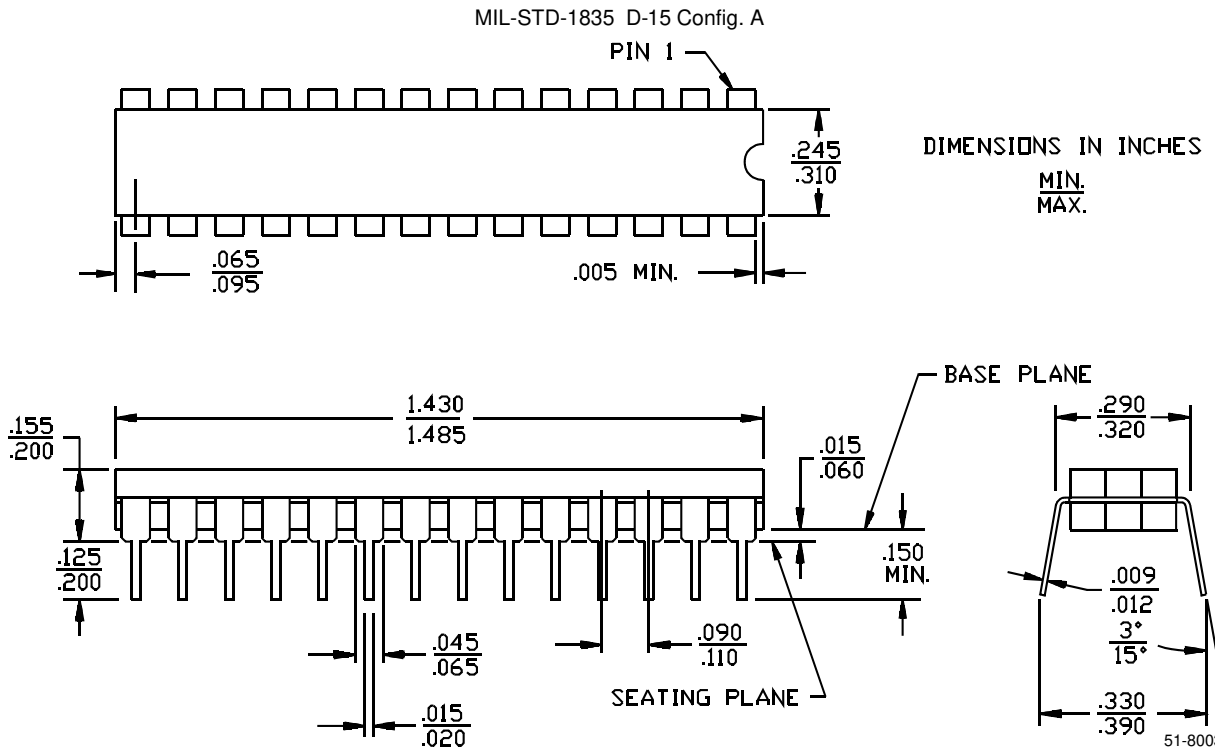
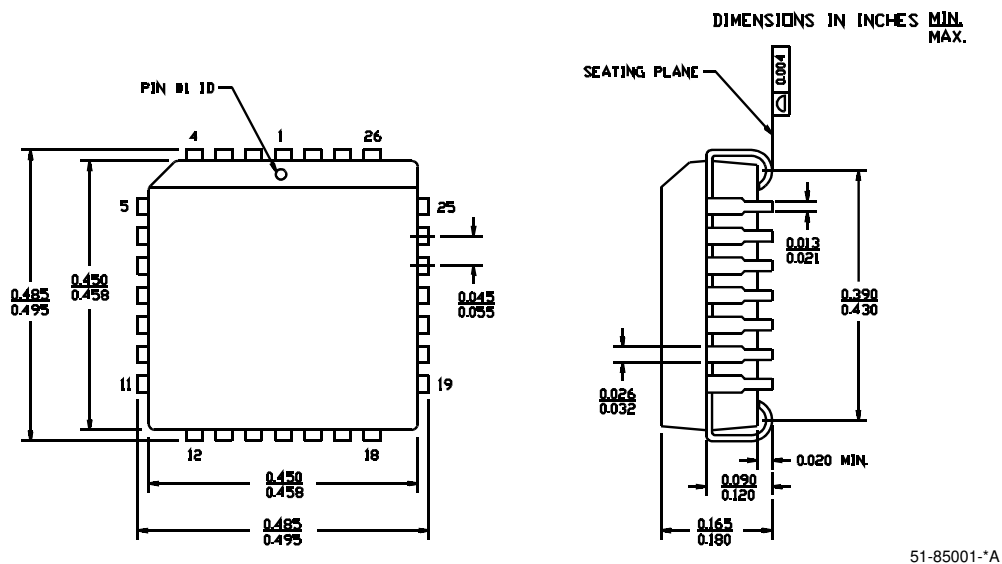

Figure 3. 28-Lead Plastic Leaded Chip Carrier J64



Package Diagrams (continued)

Figure 4. 28-Lead (300-Mil) Molded DIP P21

28-Lead (300-Mil) PDIP P21

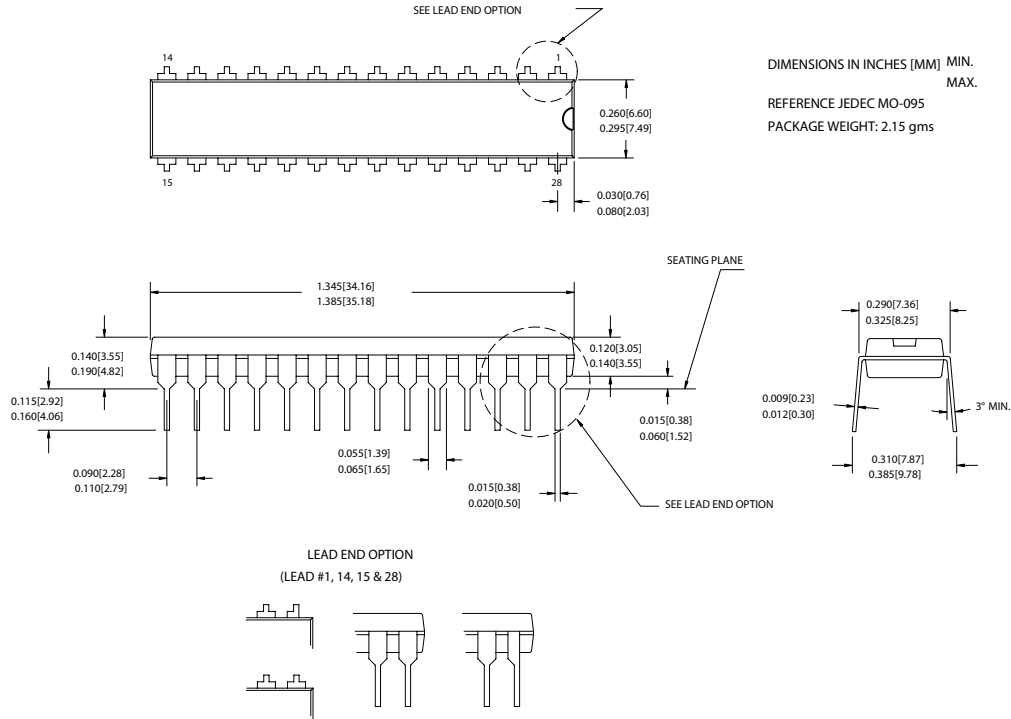

51-85014-\*D

Package Diagrams (continued)

Figure 5. 28-Lead (300-Mil) Windowed CerDIP W22

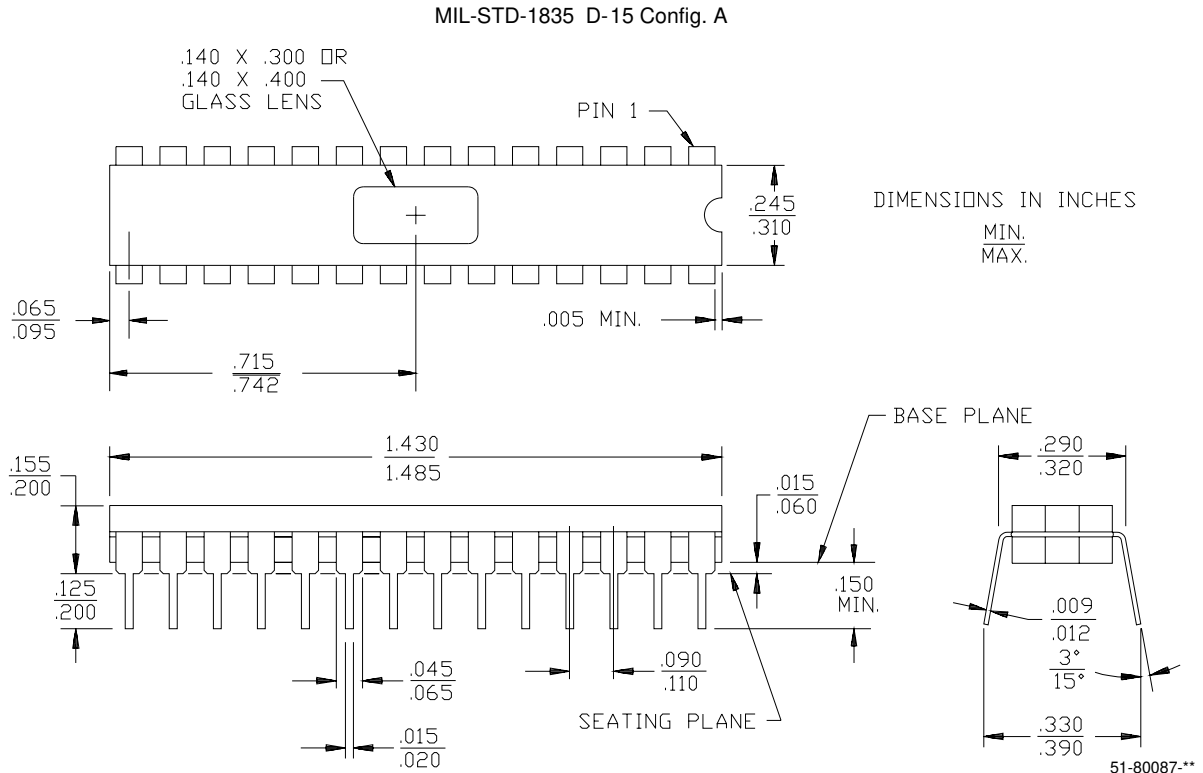

All product and company names mentioned in this document may be the trademarks of their respective holders.

**Document History Page**

<b>Document Title: CY7C265 8K x 8 Registered PROM</b>				
<b>Document Number: 38-04012</b>				
<b>REV.</b>	<b>ECN NO.</b>	<b>Issue Date</b>	<b>Orig. of Change</b>	<b>Description of Change</b>
**	114139	03/18/02	DSG	Changed from Spec number: 38-00084 to 38-04012
*A	118896	10/09/02	GBI	Updated ordering information
*B	499562	See ECN	PCI	Updated ordering information