

DRAWING MADE IN AMERICAN PROJECTION

© 1971 BY AMP INCORPORATED. ALL RIGHTS RESERVED. AMP PRODUCTS COVERED BY PATENTS AND/OR PATENTS PENDING.

THIS PRODUCT DESIGNED AND BUILT BY AMP INCORPORATED. NO LICENSE TO USE THAT DESIGN IN MANUFACTURE, OR TO USE ANY ISSUED OR PENDING PATENTS WHICH ARE INVOLVED, IS IMPLIED.

REVISIONS				
ZONE	LTR	DESCRIPTION	DATE	APPROVED
-	-	WAS SK-33099	1/19/71	<i>NY</i>
	A	ECN L1355.	RPH 4-26-85	<i>m.s.</i>
✓	B	OBS -1, 4, 6, 7, 9, 10 ECN 53630	2-2-87	<i>IM</i>
	C	OBSOLETE -3, 5, -8, 11 ECN L1559	5-27-87	<i>RS</i>

PART NO.	"A"
859355-1	12.00
859355-2	6.00
859355-3	8.00
859355-4	16.00
859355-5	15.00
859355-6	7.00
859355-7	9.00
859355-8	10.00
859355-9	11.00
1-859355-0	13.00
1-859355-1	14.00

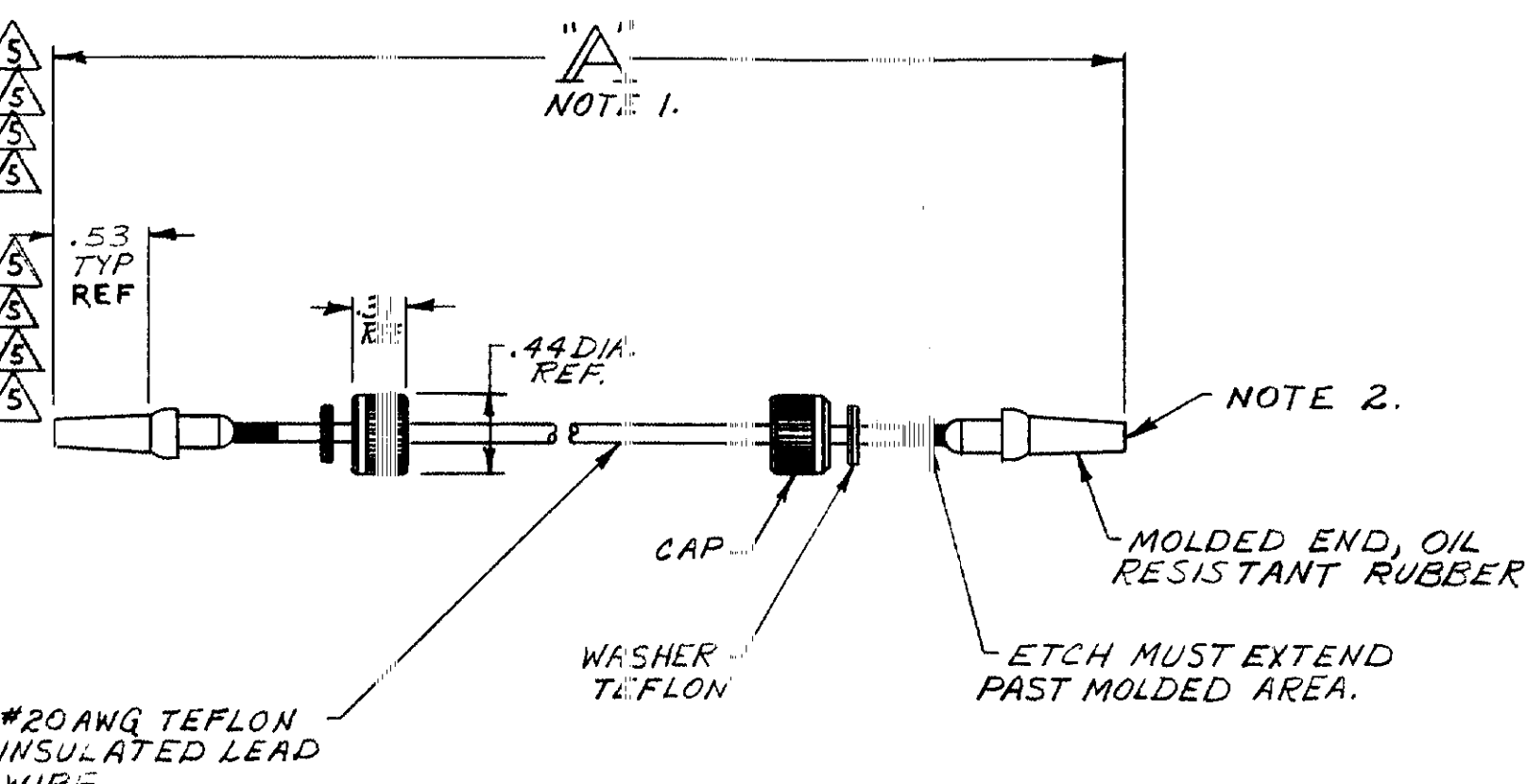

- NOTE:
1. TOLERANCE : UP TO 24" - ± .12
24" & UP - ± 1%
 2. TO MATE WITH AMP LGH -1/2 RECEPTACLE WITH .53 BARREL DEPTH
 3. MARKED PER MIL-STD-130.
 4. COLOR OF LEAD WIRE WHITE.
- Ⓜ OBSOLETE PART NO.

QTY REQD	QTY REQD	ITEM NO.	DWG SIZE	PART OR IDENTIFYING NO.	NOMENCLATURE OR DESCRIPTION	SYMBOL
-2	-1					

UNLESS OTHERWISE SPECIFIED: DIMENSIONS ARE IN INCHES TOLERANCES .00 ± .04 ANGLES .000 ± .015		CONTRACT NO. DR. <i>1-19-71</i>	 AMP INCORPORATED CAPITRON DIVISION ELIZABETHTOWN, PENNSYLVANIA
MATERIAL:		CHK APPD. <i>M. Anderson 11/9/71</i>	
FINISH:		DSGN APPD	NAME SPECIAL LGH-1/2 DOUBLE MOLDED ENDS LEAD ASS'Y
OTHER APPD		SIZE B	CODE IDENT NO. 89110
SCALE N.T.S.		WT	NUMBER 859355
SHEET 1 OF 1			

PRINT DIST 2137