

60 Watt Industrial (WLT)



Features

- 50–65 W convection-cooled rating
- Small 4 x 2 x 1.2 inches form factor
- High efficiency > 85%
- Single to triple outputs
- EN55022–B, FCC Part 15 Level B
- No Load Power < 0.3 W
- Class I & Class II options
- Cover kit accessory available
- Now IEC/ EN/UL62368-1 compliant NEW
- Approved with metal enclosures/accessories

Electrical Specifications

AC Input	90–264 V, Universal	
Input Frequency ⁵	47–400 Hz	
Input Current	120 VAC: 1.5 A max.	230 VAC: 0.75 A max.
No Load Power	< 0.3 W for single output models < 0.5 W for multi output models	
Inrush Current	120 VAC: 30 A max.	230 VAC: 60 A max.
Leakage Current	120 VAC: < 500 μ A	230 VAC: < 1000 μ A
Efficiency ¹	120 VAC: 85% typical	230 VAC: 85% typical
Hold-up Time	>10 ms @ 120 VAC typical	
Output Power	50–65 W	
Line Regulation	+/-0.3%	
Load Regulation	V1: +/-0.5%; V2 & V3: +/-5%	
Transient Response	< 10%, 50% to 100% load change, 50/60 Hz, 50% duty cycle, 0.1 A/ μ s, recovery time < 5 ms	
Rise Time	< 100 ms	
Set Point Tolerance	V1: +/-3%; V2 & V3: +/-5%	
Output Adjustability	V1: +/-10%	
Over Current Protection	130% typical above rating	
Over Voltage Protection	130% typical for V1 only	
Short Circuit Protection	Short term, autorecovery	
Switching Frequency	Approximately 67 kHz	
Operating Temperature	–20 to 70°C, refer derating curve; –20 to 0°C, start-up is guaranteed	
Storage Temperature	–40 to +85°C	
Relative Humidity	95% Rh, noncondensing	
Altitude	Operating: 10,000 ft.; Nonoperating: 40,000 ft.	
MTBF	1.87m Hours, Telcordia -SR332-issue 3	
Isolation Voltage	Input to Output 4000 VAC/VDC	
Cooling	Convection	

Model Number	Power Supply Unit & its Installation Type	Maximum Wattage	Voltage	Max. Load ³	Min. Load ⁶	Ripple ⁴
LFWLT60-1000-CK	In CK cover Kit ¹¹	35W	V1=5.0 V	7.0 A	0.00 A	1.5%
LFWLT60-1000	In Open Frame	50W	V1=5.0 V	10.0 A	0.00 A	1.5%
LFWLT60-1000-L	With L Bracket					
LFWLT60-1000-B	With Base Plate					
LFWLT60-1000-U	With U channel					
LFWLT60-1001-CK	In CK cover Kit ¹¹	45.5W	V1=12 V	3.79 A	0.00 A	1%
LFWLT60-1001	In Open Frame	65W	V1=12 V	5.42 A	0.00 A	1%
LFWLT60-1001-L	With L Bracket					
LFWLT60-1001-B	With Base Plate					
LFWLT60-1001-U	With U channel					
LFWLT60-1002-CK	In CK cover Kit ¹¹	45.5W	V1=15 V	3.03 A	0.00 A	1%
LFWLT60-1002	In Open Frame	65W	V1=15 V	4.33 A	0.00 A	1%
LFWLT60-1002-L	With L Bracket					
LFWLT60-1002-B	With Base Plate					
LFWLT60-1002-U	With U channel					
LFWLT60-1003-CK	In CK cover Kit ¹¹	45.5W	V1=24 V	1.89 A	0.00 A	1%
LFWLT60-1003	In Open Frame	65W	V1=24 V	2.71 A	0.00 A	1%
LFWLT60-1003-L	With L Bracket					
LFWLT60-1003-B	With Base Plate					
LFWLT60-1003-U	With U channel					
LFWLT60-1004-CK	In CK cover Kit ¹¹	45.5W	V1=48 V	0.94 A	0.00 A	1%
LFWLT60-1004	In Open Frame	65W	V1=48 V	1.35 A	0.00 A	1%
LFWLT60-1004-L	With L Bracket					
LFWLT60-1004-B	With Base Plate					
LFWLT60-1004-U	With U channel					
LFWLT60-3000-CK	In CK cover Kit ¹¹	42W				
LFWLT60-3000	In Open Frame	60W	V1=5.2 V,	V1=8.0 A,	V1=0.5 A,	V1=1.5 %, V2 & V3=1 %
LFWLT60-3000-L	With L Bracket		V2=12.5 V,	V2=3.0 A,	V2=0.1 A,	
LFWLT60-3000-B	With Base Plate		V3=-12.8 V	V3=0.5 A,	V3=0.0 A	
LFWLT60-3000-U	With U channel					
LFWLT60-3001-CK	In CK cover Kit ¹¹	42W				
LFWLT60-3001	In Open Frame	60W	V1=5.2 V,	V1=8.0 A,	V1=0.5 A,	V1=1.5 %, V2 & V3=1 %
LFWLT60-3001-L	With L Bracket		V2=24 V,	V2=1.5 A,	V2=0.1 A,	
LFWLT60-3001-B	With Base Plate		V3=-12.8 V	V3=0.5 A	V3=0.0 A	
LFWLT60-3001-U	With U channel					
LFWLT60-3002-CK	In CK cover Kit ¹¹	42W				
LFWLT60-3002	In Open Frame	60W	V1=5.2 V,	V1=8.0 A,	V1=0.5 A,	V1=1.5 %, V2 & V3=1 %
LFWLT60-3002-L	With L Bracket		V2=15 V,	V2=2.5 A,	V2=0.1 A,	
LFWLT60-3002-B	With Base Plate		V3=-15 V	V3=0.5 A	V3=0.0 A	
LFWLT60-3002-U	With U channel					
LFWLT60-3003-CK	In CK cover Kit ¹¹	31.5W				
LFWLT60-3003	In Open Frame	45W	V1=3.3 V,	V1=6.0 A,	V1=1.0 A,	V1=1.5 %, V2 & V3=1 %
LFWLT60-3003-L	With L Bracket		V2=5 V,	V2=3.0 A,	V2=0.1 A,	
LFWLT60-3003-B	With Base Plate		V3=-12.8 V	V3=0.5 A	V3=0.0 A	
LFWLT60-3003-U	With U channel					



Innovations in Power

Connectors		
J1	Pin 1	AC LINE
	Pin 2	AC NEUTRAL
Spade Connector		EARTH
J2	Pin 1	V1
	Pin 2	V1
	Pin 3	RTN
	Pin 4	RTN
	Pin 5	V3
	Pin 6	V2
J3	Pin 1	+V1 SENSE
	Pin 2	-V1 SENSE

Notes

1. For WLT60-3003 efficiency is 75% typical.
2. Single output models deliver 65 W, except WLT60-1000 (50 W).
Triple output models deliver 60 W, except WLT60-3003 (45 W).
3. Maximum current per output channel. Do not exceed total output power rating.
4. Ripple is peak to peak with 20 MHz bandwidth and 10 μ F (Electrolytic capacitor) in parallel with a 0.1 μ F capacitor at rated line voltage and load ranges.
5. Safety approved 47-63 Hz.
6. Min Load specified to meet cross regulation.
7. Class II version available. Add "-2" suffix at the end of the Model Number to Order. Enquire with EOS Sales Rep before Order.
8. Specifications are for nominal input voltage, 25°C and max. load unless otherwise stated.
9. Derate output power linearly to 80% from 90 VAC to 80 VAC input.
10. Please refer mechanical outline drawing for height of component above and below PCB for - 1xxx & 3xxx.
11. When used in Cover Kit, de-rate output power to 70 % under all operating conditions

Mechanical Specifications	
AC Input Connector (J1)	Molex: 26-60-4030 or equivalent Mating: 09-50-3031; Pins: 08-50-0106
EARTH	Molex: 19705-4301 Mating: 190030001
DC Output Connector (J2)	Tyco: 640445-6 or equivalent Mating: 647402-6; Pins: 3-647409-1
Signal Connector (J3)	Molex: 22-23-2021 or equivalent Mating: 22-01-2021
Dimensions	4.0 x 2.0 x 1.2 inches (101.6 x 50.8 x 30.48 mm)
Weight	150 g

EMC*

Parameter	Conditions/Description	Criteria
Conducted Emissions	EN55032-B, CISPR22-B, FCC PART15-B	Pass
Radiated Emissions	EN 55032 B	Pass
Input Current Harmonics	EN 61000-3-2	Class A
Voltage Fluctuation and Flicker	EN 61000-3-3	Pass
ESD Immunity	EN 61000-4-2	Level 3, Criterion A
Radiated Field Immunity	EN 61000-4-3	Level 3, Criterion A
Electrical Fast Transient Immunity	EN 61000-4-4	Level 3, Criterion A
Surge Immunity	EN 61000-4-5	Level 3, Criterion A
Conducted Immunity	EN 61000-4-6	Level 3, Criterion A
Magnetic Field Immunity	EN 61000-4-8	Level 3, Criterion A
Voltage dips, interruptions	EN 61000-4-11	Criterion A & B

Safety*

CE Mark	Complies with LVD Directive
Approval Agency	Nemko, UL, C-UL
Safety Standard(s)	IEC60950-1(ed.2), EN 60950-1, UL60950-1 (2nd Edition), CSA C22.2 No. 60950-1 (2nd Edition), UL 62368-1, 2nd Ed, 2014-12-01 CAN/CSA C22.2 No. 62368-1-14, 2nd Ed, Class1 SELV IEC 62368-1:2014, EN 62368-1:2014; A11
*Safety File Number(s)	Class I : Nemko: P15220205, N088354 UL/C-UL: E150565, 20190628-E150565 Class II : Nemko: P13216532, N072728 UL/C-UL: E150565

Derating Curve

**Power de-rating in open frame/ with L Bracket
/Base plate /with U Channel**

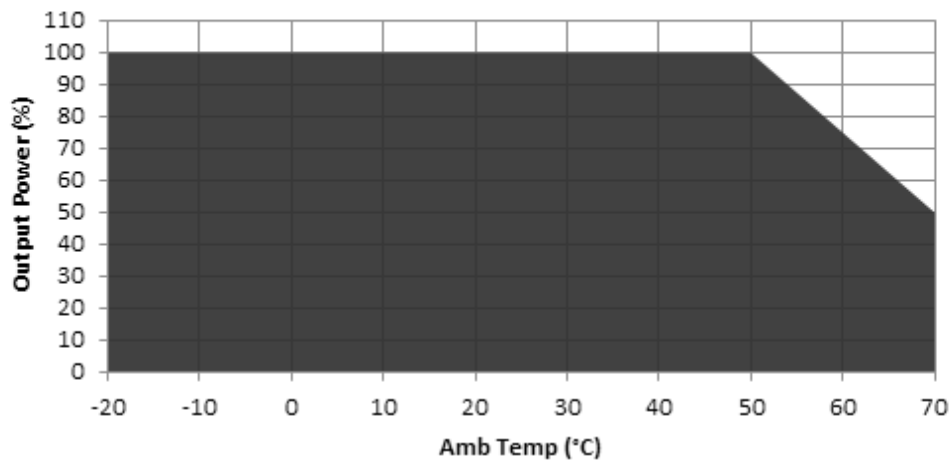

De-rate linearly from 100% at 50°C to 50% at 70°C



Innovations in Power

Derating Curve

Power de-rating in CK cover kit

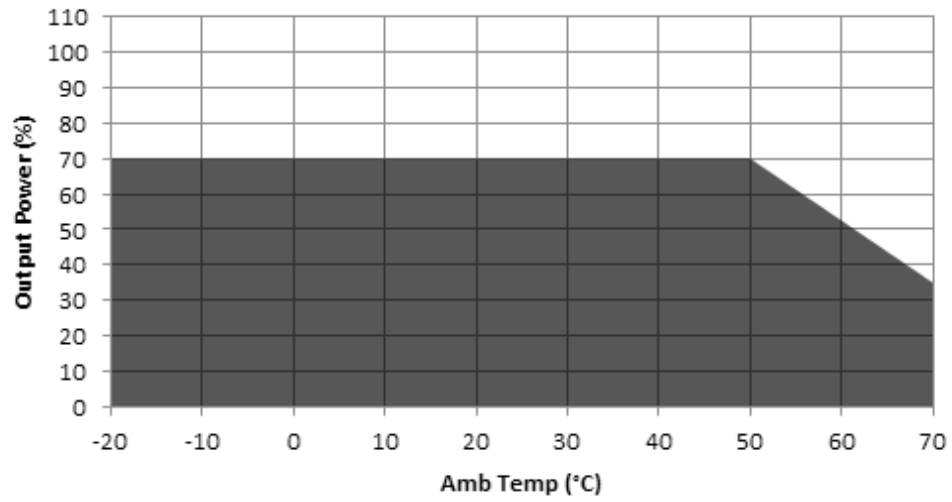

De-rate linearly from 70% at 50°C to 35% at 70°C



Innovations in Power

Mechanical Drawing

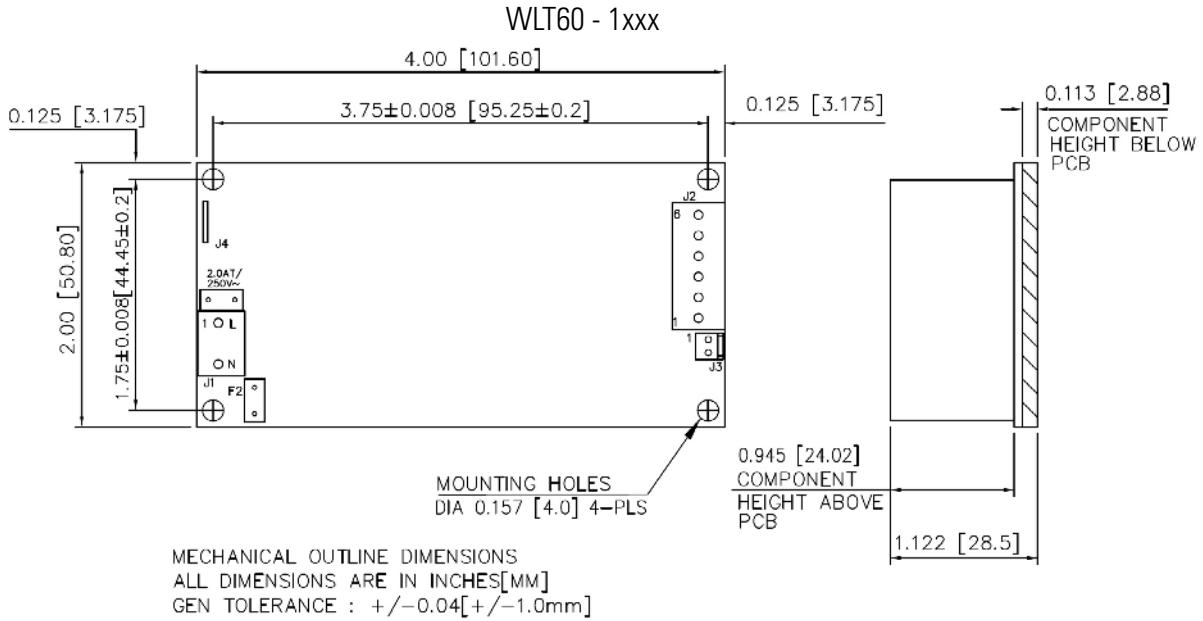

Notes: In case the PCB is mounted in a metal enclosure, using metal hardware ensure the following

1. Stand off, used to mount PCB has OD of 5.4 mm max.
2. Screws, used to fix PCB on stand off, have head dia of 6.0 mm max.
3. Washer, if used, to have dia of 6.5 mm max.

Mechanical Drawing

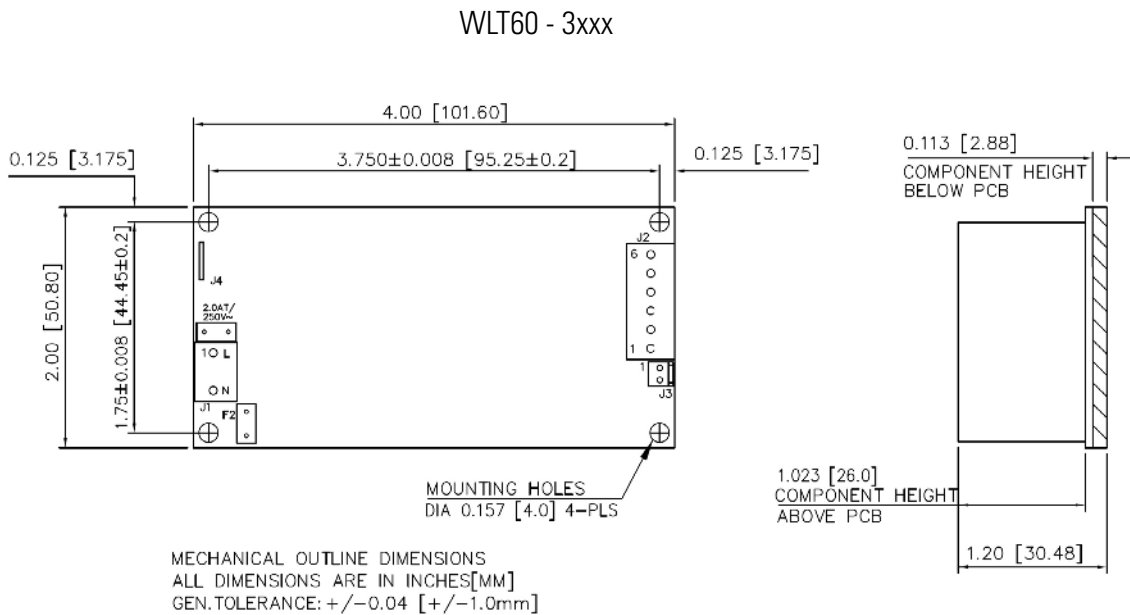

Notes: In case the PCB is mounted in a metal enclosure, using metal hardware ensure the following

1. Stand off, used to mount PCB has OD of 5.4 mm max.
2. Screws, used to fix PCB on stand off, have head dia of 6.0 mm max.
3. Washer, if used, to have dia of 6.5 mm max.

Mechanical Drawing

WLT60 (1XXX) WITH BASE PLATE

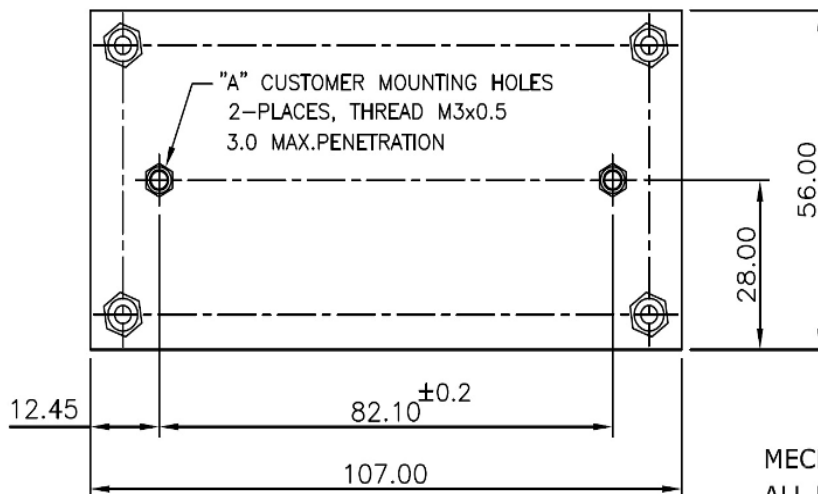
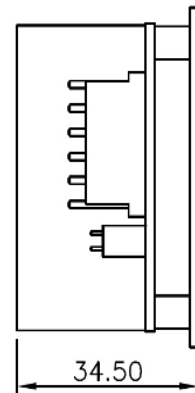
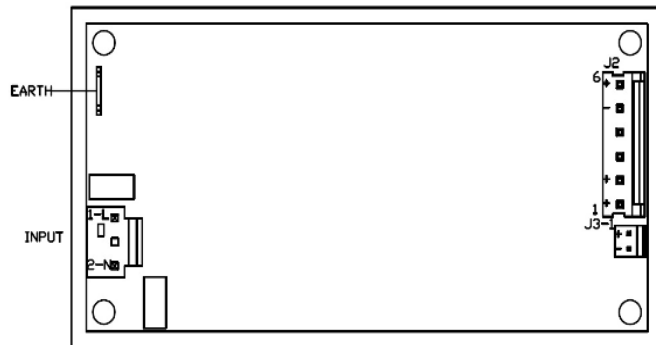

MECHANICAL OUTLINE DIMENSIONS
ALL DIMENSIONS ARE IN MM
GEN.TOLERANCE: +/-0.5 MM

Notes: In case the PCB is mounted on a metal base plate, using metal hardware ensure the following

1. Stand off, used to mount PCB has OD of 5.4 mm max.
2. Screws, used to fix PCB on stand off, have head dia of 6.0 mm max.
3. Washer, if used, to have dia of 6.5 mm max.



Innovations in Power

Mechanical Drawing

WLT60 (3XXX) WITH BASE PLATE

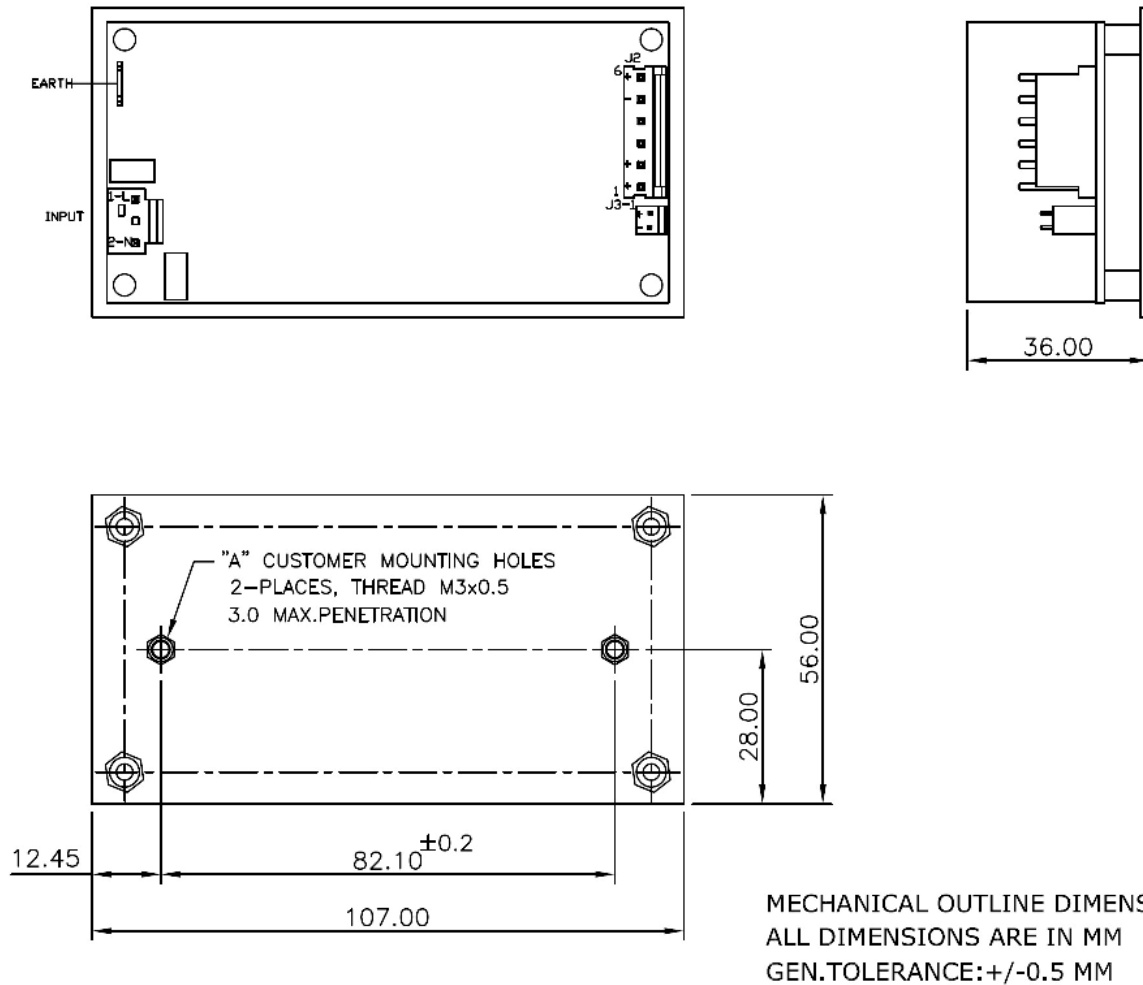

Notes: In case the PCB is mounted on a metal base plate, using metal hardware ensure the following

1. Stand off, used to mount PCB has OD of 5.4 mm max.
2. Screws, used to fix PCB on stand off, have head dia of 6.0 mm max.
3. Washer, if used, to have dia of 6.5 mm max.

Mechanical Drawing

WLT60 SERIES WITH 'L' BRACKET

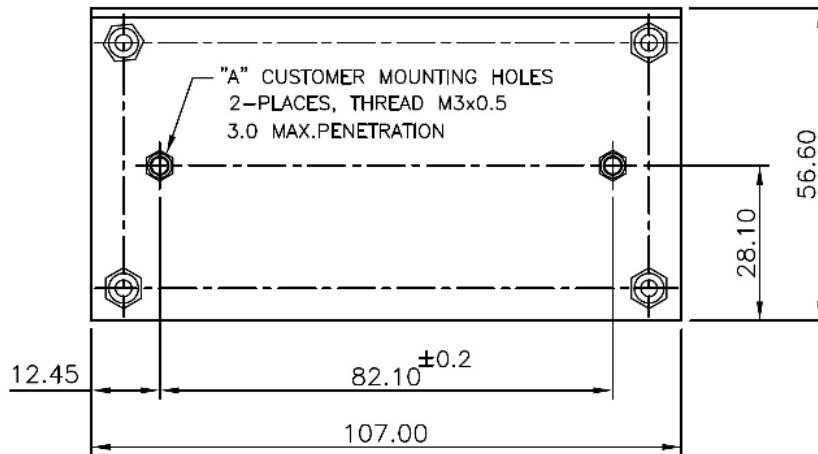
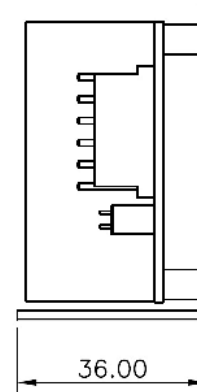
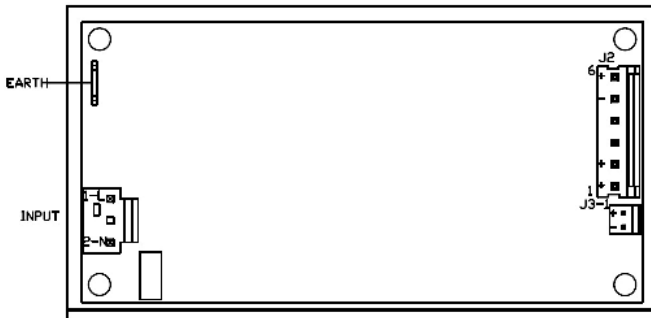

MECHANICAL OUTLINE DIMENSIONS
ALL DIMENSIONS ARE IN MM
GEN.TOLERANCE: +/-0.5 MM

Notes: In case the PCB is mounted in a metal 'U,' channel, using metal hardware ensure the following

1. Stand off, used to mount PCB has OD of 5.4 mm max.
2. Screws, used to fix PCB on stand off, have head dia of 6.0 mm max.
3. Washer, if used, to have dia of 6.5 mm max.



Innovations in Power

Mechanical Drawing

WLT60 SERIES WITH 'U' CHANNEL

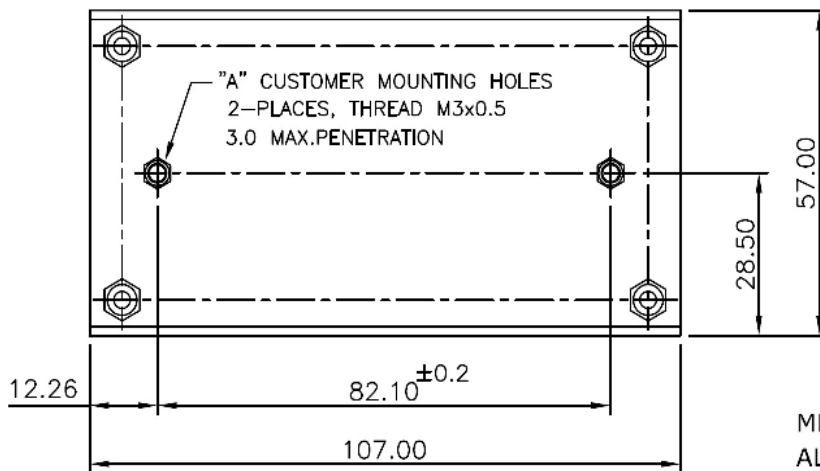
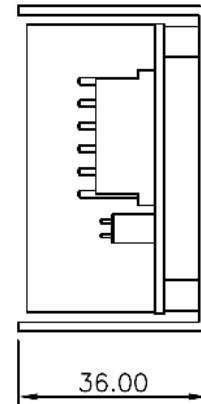
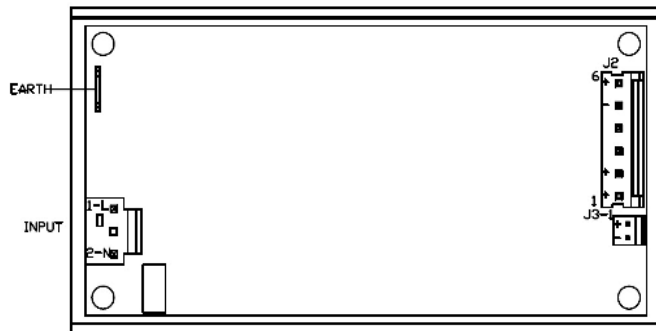

MECHANICAL OUTLINE DIMENSIONS
ALL DIMENSIONS ARE IN MM
GEN.TOLERANCE: +/-0.5 MM

Notes: In case the PCB is mounted in a metal 'U,' channel, using metal hardware ensure the following

1. Stand off, used to mount PCB has OD of 5.4 mm max.
2. Screws, used to fix PCB on stand off, have head dia of 6.0 mm max.
3. Washer, if used, to have dia of 6.5 mm max.

Mechanical Drawing

WLT60 SERIES WITH COVER KIT

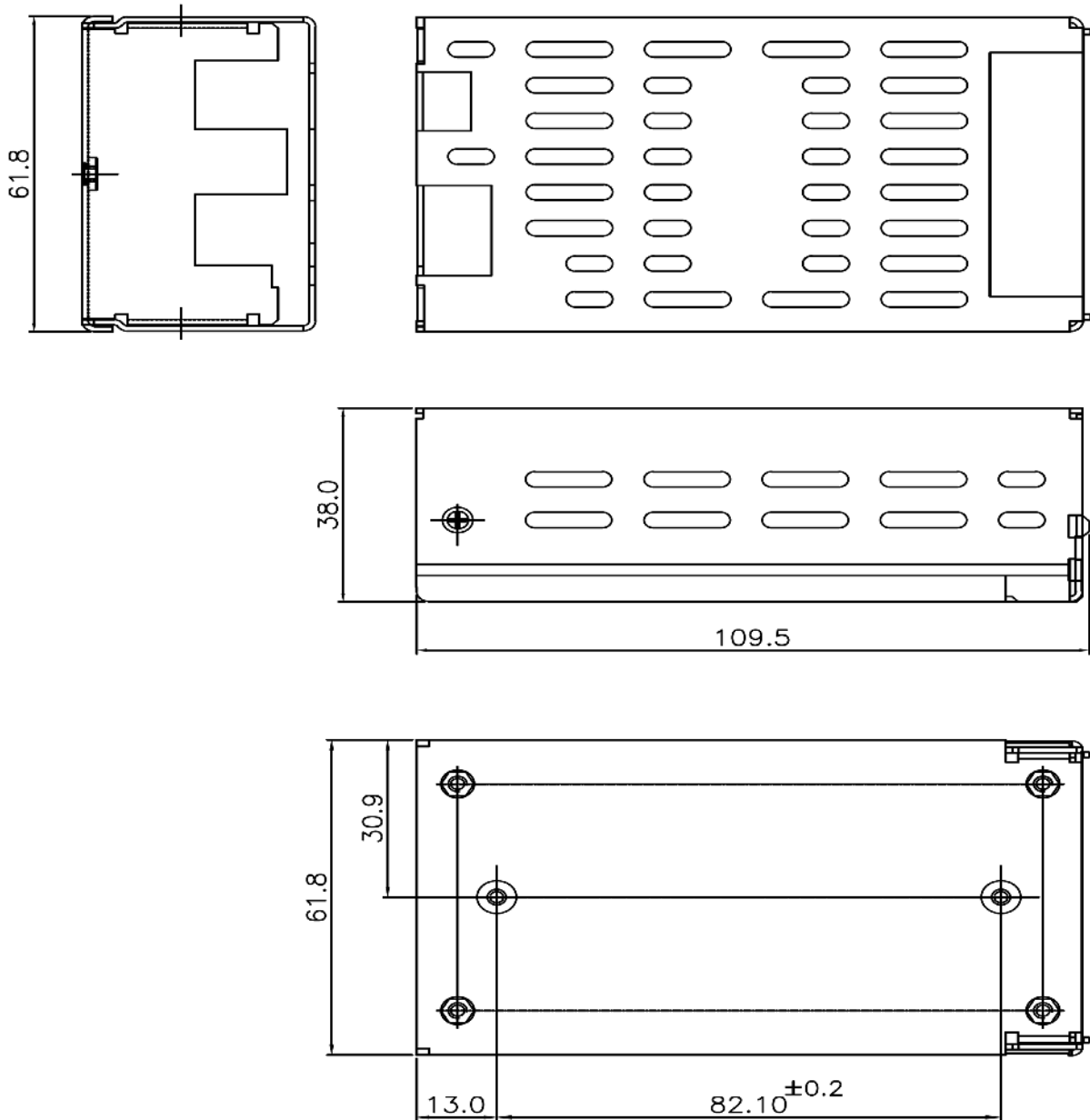

MECHANICAL OUTLINE DIMENSIONS
ALL DIMENSIONS ARE MM
GEN TOLERANCE : ± 0.5 mm

- Notes: In case the PCB is mounted in a metal cover kit, using metal hardware ensure the following
1. Stand off, used to mount PCB has OD of 5.4 mm max.
 2. Screws, used to fix PCB on stand off, have head dia of 6.0 mm max.
 3. Washer, if used, to have dia of 6.5 mm max.



Innovations in Power